



*Service  
Manual*

**ELECTRICAL**



**3000GT**



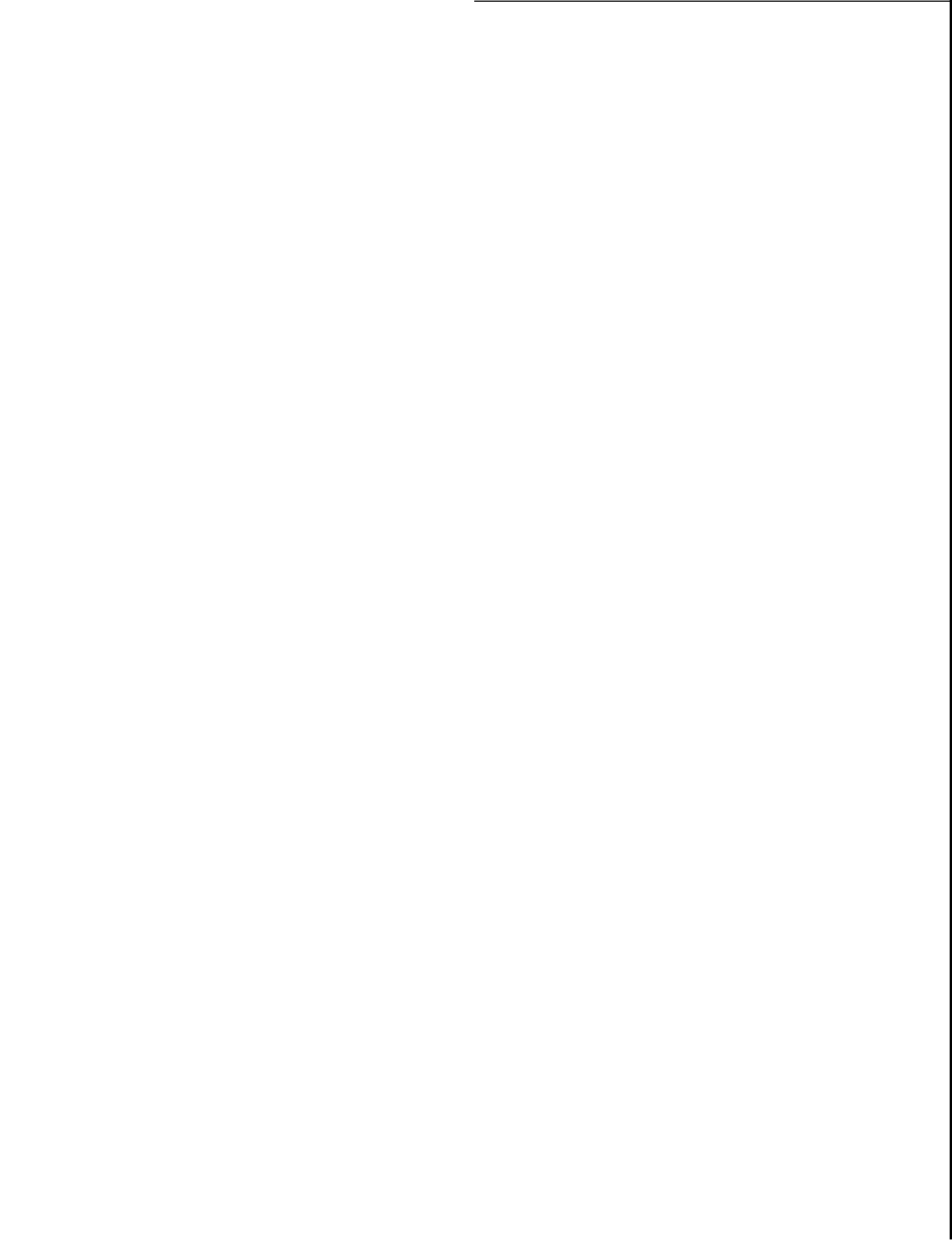



# Service Manual

# 3000GT

1992-1 996

Volume 2

## Electrical

### FOREWORD

This Service Manual has been prepared with the latest service information available at the time of publication. It is subdivided into various group categories and each section contains diagnosis, disassembly, repair, and installation procedures along with complete specifications and tightening references. Use of this manual will aid in properly performing any servicing necessary to maintain or restore the high levels of performance and reliability designed into these outstanding vehicles.



Mitsubishi Motors Corporation reserves the right to make changes in design or to make additions to or improvements in its products without imposing any obligations upon itself to install them on its products previously manufactured.

## GROUP / SECTION INDEX

General .....	
Fusible Link, Fuse and IOD or Storage Connector Location .....	
Inspection Terminal Location .....	
Grounding Location .....	
Relay Location .....	
Sensor Location .....	
Control Unit Location .....	
Solenoid, Solenoid Valve Location .....	
Diode Location .....	
Junction Block .....	
Centralized Junction .....	
Harness Connector Inspection .....	
How to Diagnose .....	
Configuration Diagrams .....	
Circuit Diagrams . . . . *	
Engine Electrical .....	16
Chassis Electrical .....	54
Alphabetical Index .....	

#### NOTE:

For information concerning all components other than the electrical system and on-vehicle service procedures for engines and transmissions, refer to Volume 1 "Chassis & Body" of this paired Service Manual.

For overhaul procedures of engines or transmission, refer to the separately issued Engine Service Manual or Manual/Automatic Transmission Service Manual.



**FUSIBLE LINK, FUSE AND IOD OR STORAGE CONNECTOR LOCATION**

Name	Symbol	Name	Symbol
Dedicated fuse No. 1 to No. 7	B	Fusible link	A
Dedicated fuse No. 8 and No. 9	C	IOD or Storage connector	B
Dedicated fuse No. 10	E	Multi-purpose fuse	D

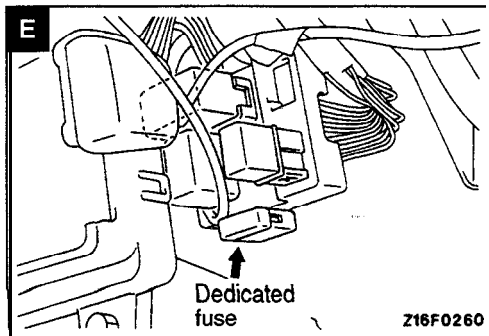
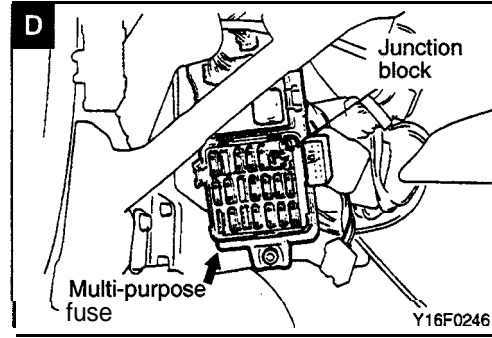
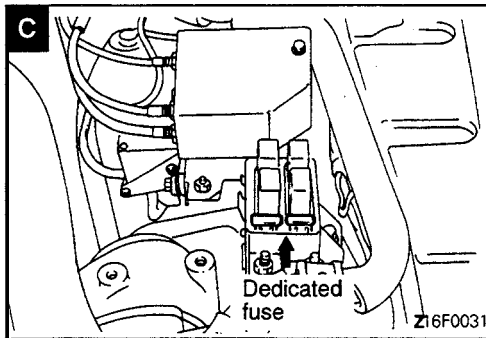
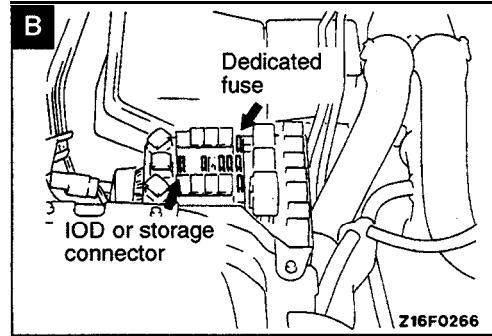
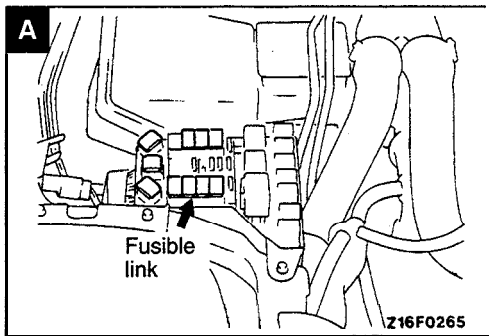
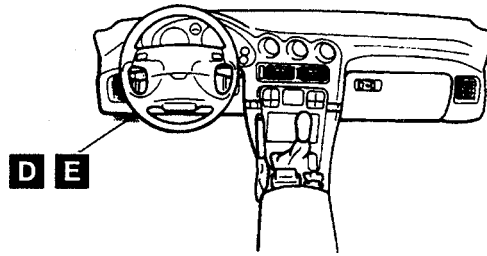
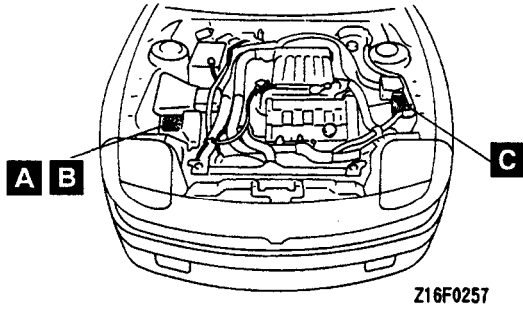



**INSPECTION TERMINAL LOCATION**

Name	Symbol	Name	Symbol
Data link connector <From 1994 models>	C	Fuel pump check connector	A
Data link connector <Up to 1993 models>	B	Ignition timing adjustment connector	A
Engine speed detection connector	A		

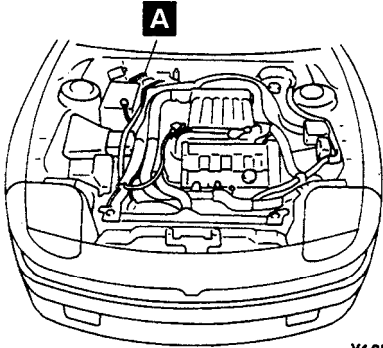

Y16F0257

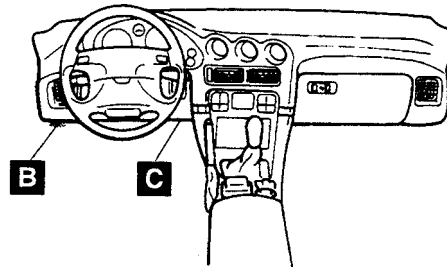

Y19F0134  
00002697

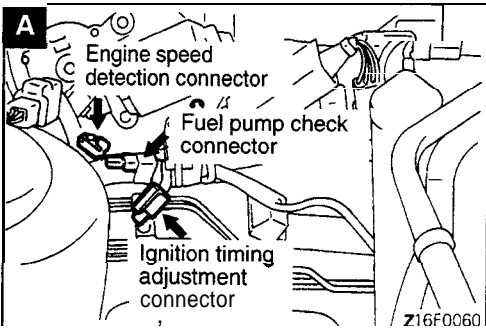

Z16F0060

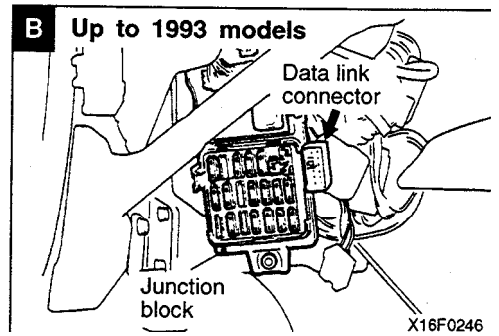

X16F0246

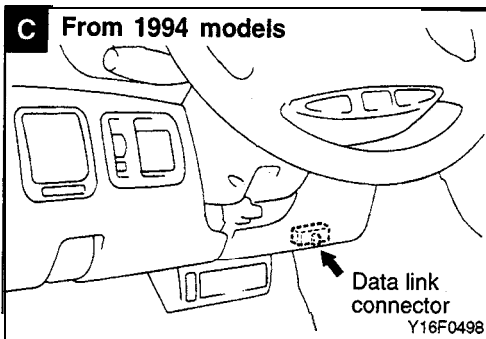

Y16F0498



# GROUNDING LOCATION

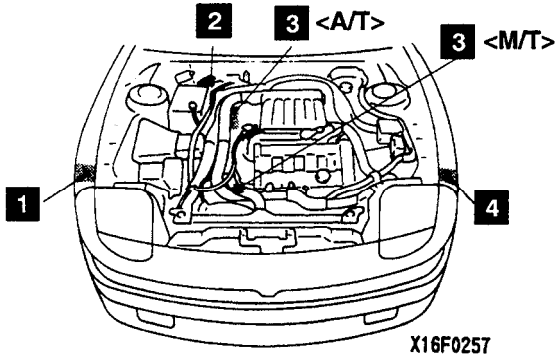

X16F0257

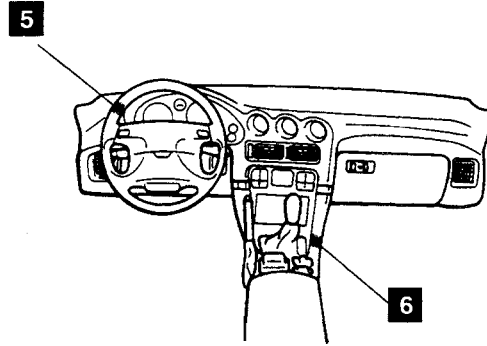

XI 9F0134

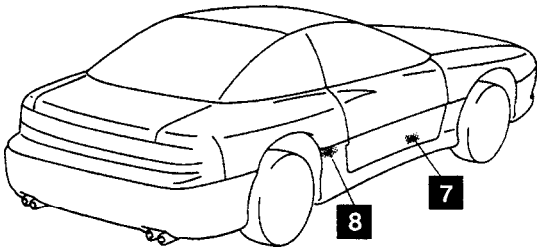

Z16F0267

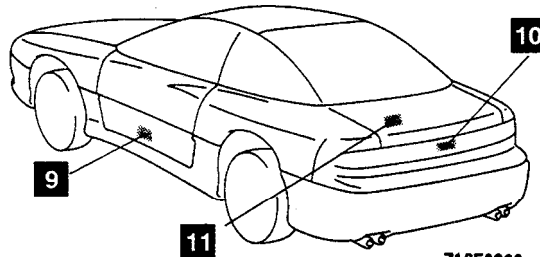

Z16F0268  
00002698

NOTE  
Same ground numbers are used in the circuit diagram.

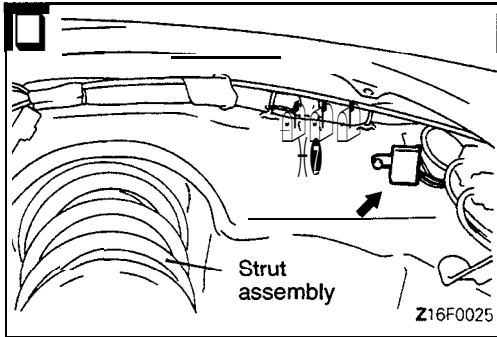

Z16F0025

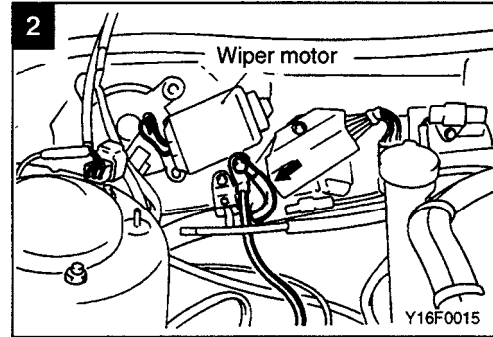

Y16F0015

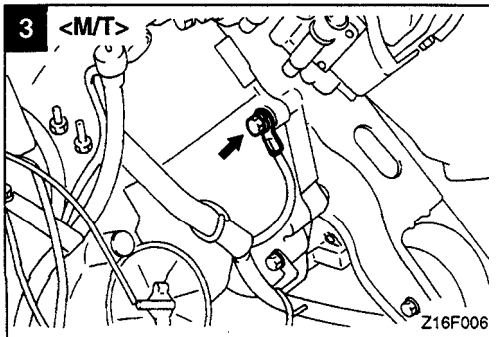

Z16F006

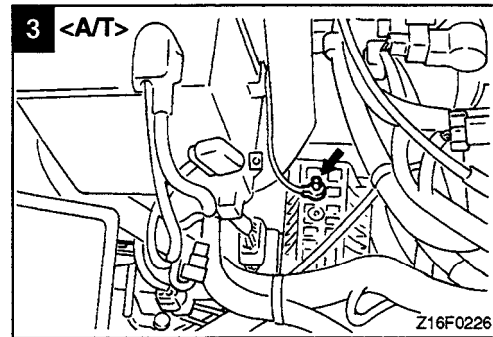

Z16F0226



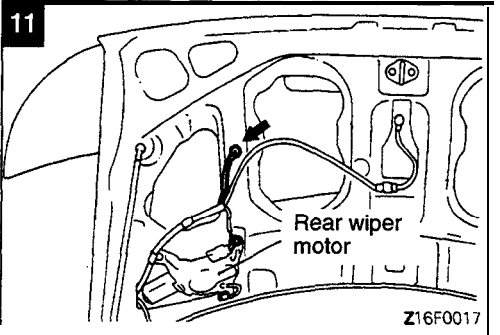
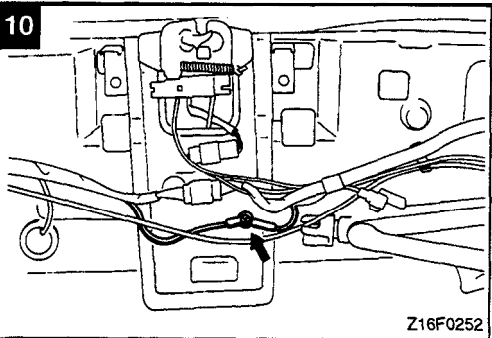
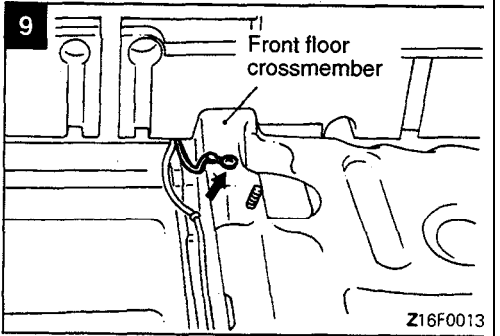
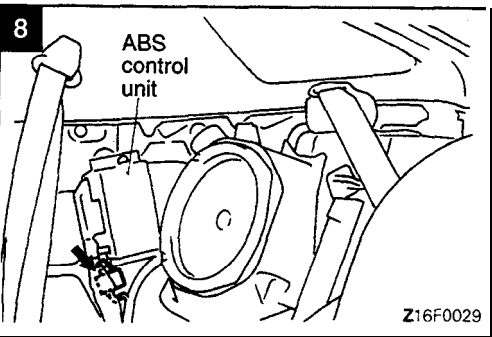
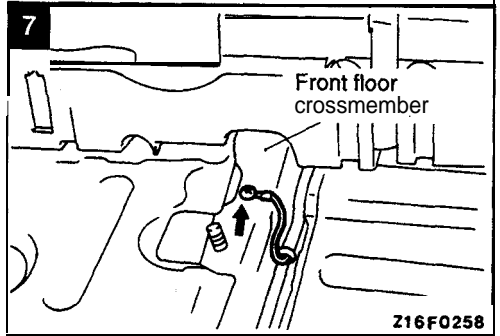
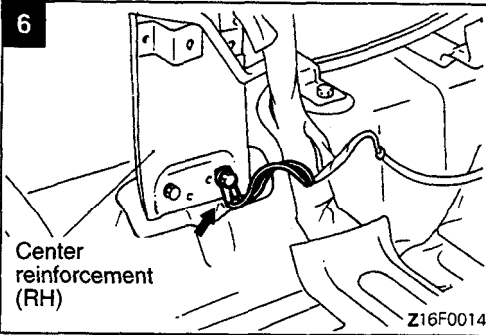
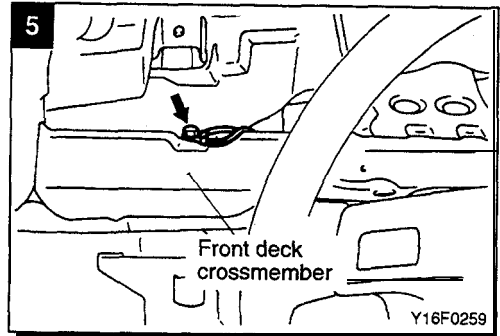
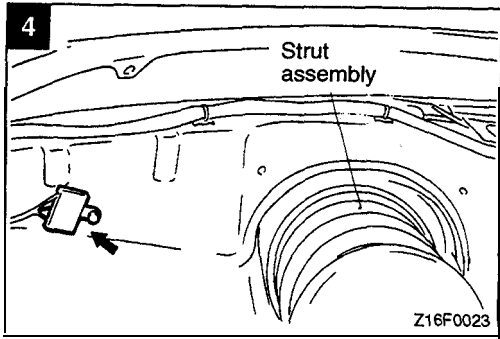



**RELAY LOCATION**

Name	Symbol	Name	Symbol
ABS power relay*1	A	MFI relay	J
Auto-cruise control relay	I	Motor relay (ABS hydraulic unit)	B
Blower motor relay	E	Pop-up motor relay*3	A
Blower motor relay (HI)*5	K	Power window relay	F
Condenser fan motor relay (HI)	D	Radiator fan motor control relay*3	D
Condenser fan motor relay (LO)	D	Radiator fan motor relay (HI)	A
Defogger relay	F	Radiator fan motor relay (LO)	A
Door lock power relay 1	F	Rear intermittent wiper relay	L
Door lock power relay 2 • 2	L	Starter relay	A
Fog light relay	A	Tail light relay	A
Fuel pump relay	C	Theft-alarm horn relay*4	E
Generator relay	A	Theft-alarm starter relay*4	H
Headlight relay	A	Turn-signal and hazard flasher unit	G
Horn relay	A	Valve relay (ABS hydraulic unit)	B
Magnetic clutch relay	D		

**NOTE**

- (1) \*1: Vehicles produced up to Oct. 1993.
- (2) ● 2: Except 1993 and earlier models without keyless entry system.
- (3) \*3: Up to 1993 models
- (4) \*4: Vehicles with theft-alarm system.
- (5) ● s: Except vehicles with manual air conditioning from 1996 models.

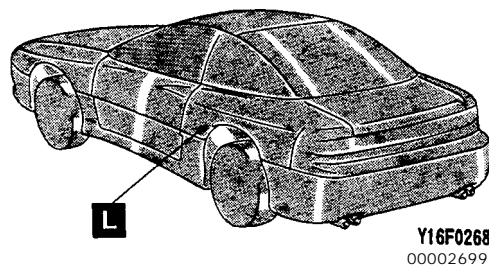
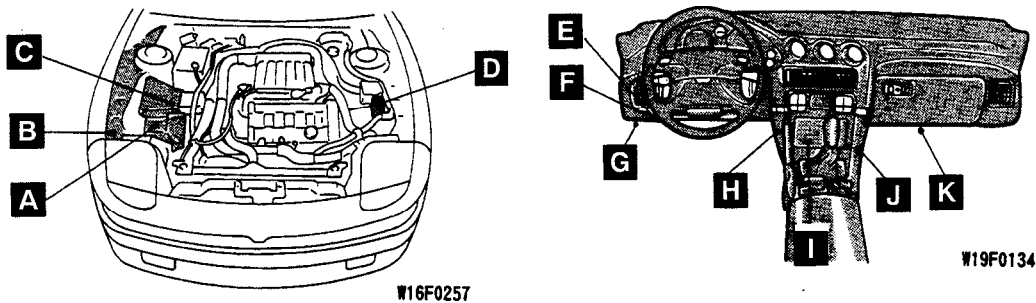

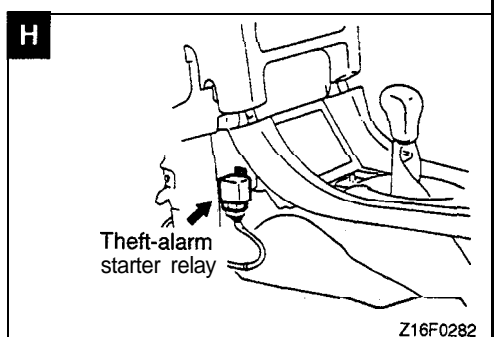
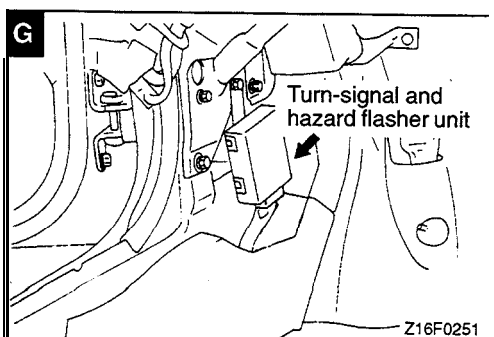
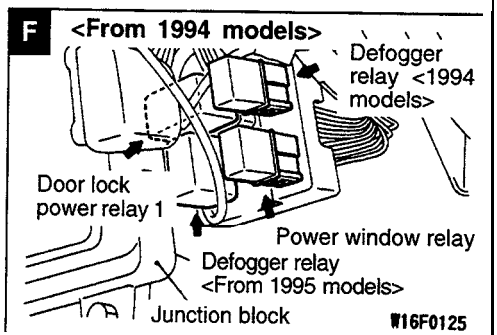
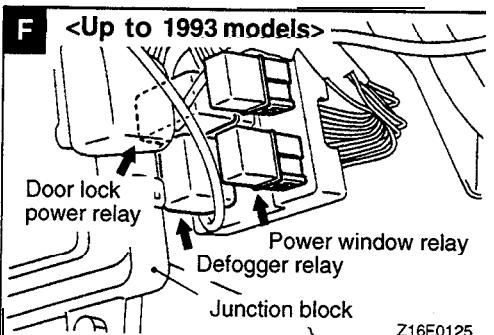
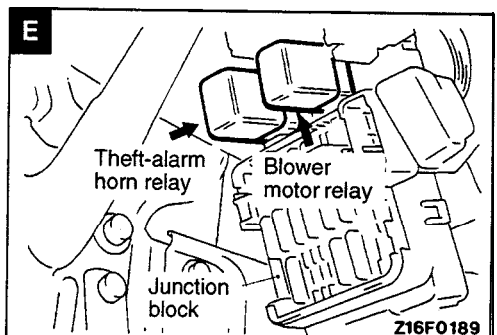
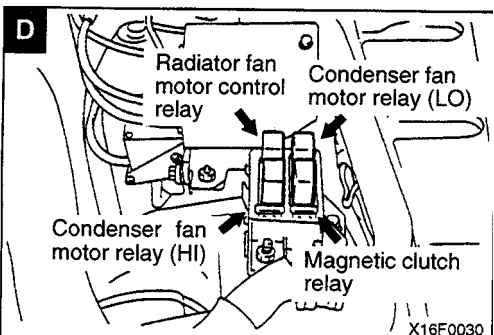
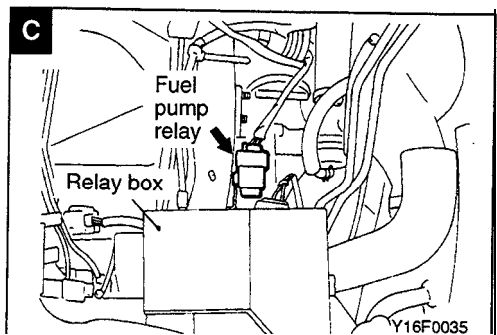
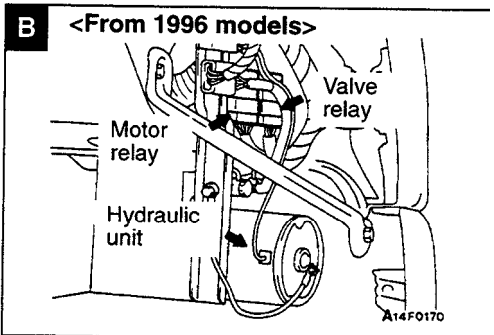
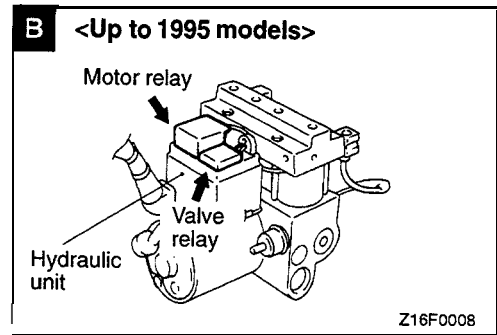
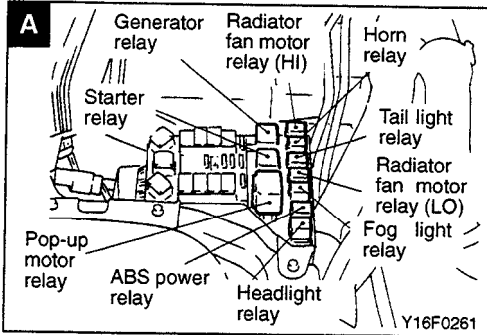



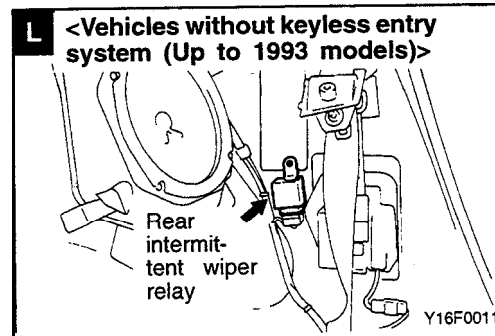
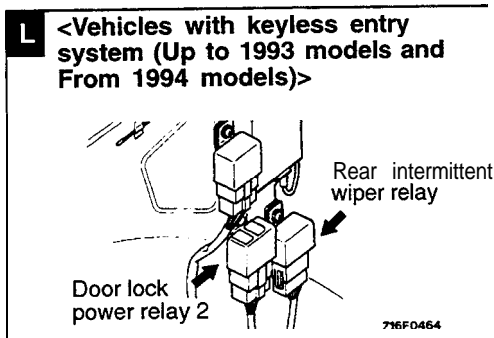
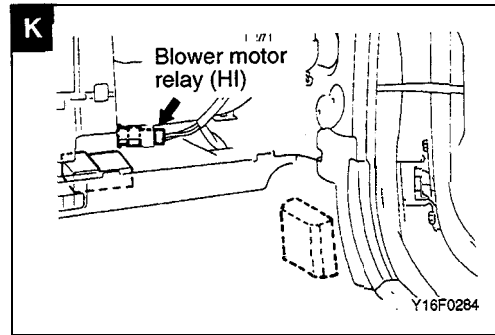
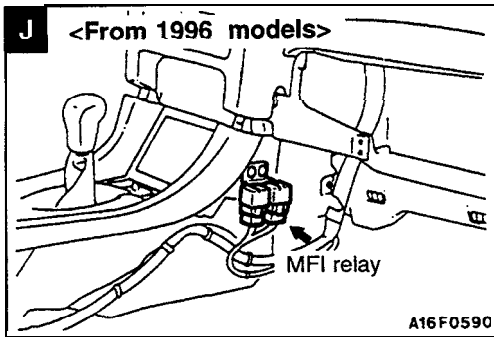
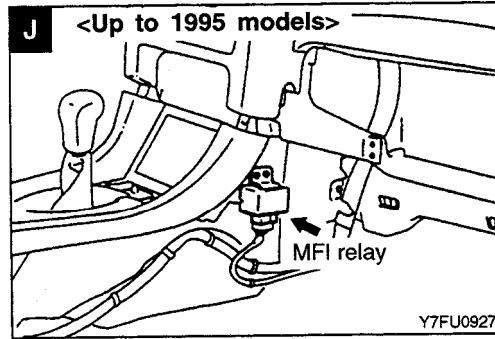
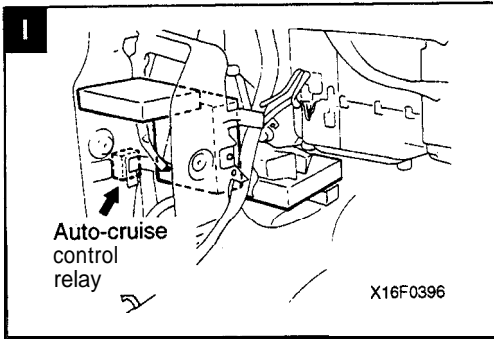

# SENSOR LOCATION

Name	Symbol	Name	Symbol
ABS front speed sensor	Y	Kickdown servo switch	M
ABS rear speed sensor	Z	Knock sensor	E
Air inlet sensor (for A/C)	S	Left bank heated oxygen sensor	D
Air thermo sensor (for A/C)	R	Manifold differential pressure sensor*4	C
Automatic transaxle oil temperature sensor <A/T>	M	Photo sensor	T
Camshaft position sensor and crankshaft position sensor*1	N	Power steering pressure switch	F
Camshaft position sensor (from 1993 model)	G	Pulse generator A, B <A/T>	M
Crankshaft position sensor (from 1993 model)	H	Revolution pick-up sensor	I
EGR temperature sensor*3 <Turbo, Non Turbo (for California)>	C	Right bank heated oxygen sensor	D
Engine coolant temperature sensor (for A/C)	Q	Steering wheel angle speed sensor	O
Engine coolant temperature sensor (for engine control)	L	Thermo sensor*2	K
Engine coolant temperature switch (for A/C)*2	L	Thermostat	I
Front impact sensor	X	Throttle position sensor	J
G sensor (for ABS)	U	Vehicle speed sensor (Reed switch)*1	P
G sensor(for ECS)*3	V	Vehicle speed sensor	B
Heated oxygen sensor*3	D	Volume air flow sensor	A
Interior temperature sensor	W		

**NOTE**

- (1) \*1: Up to 1992 models
- (2) \*2: Up to 1993 models
- (3) \*3: Up to 1995 models
- (4) \*4: From 1996 models

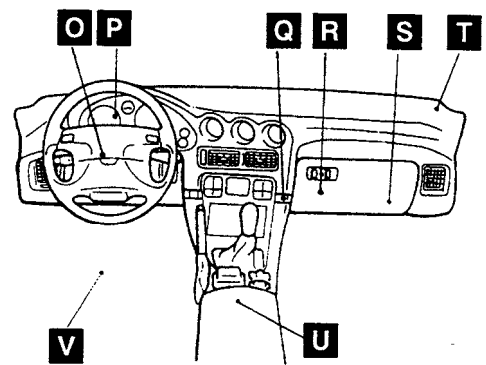
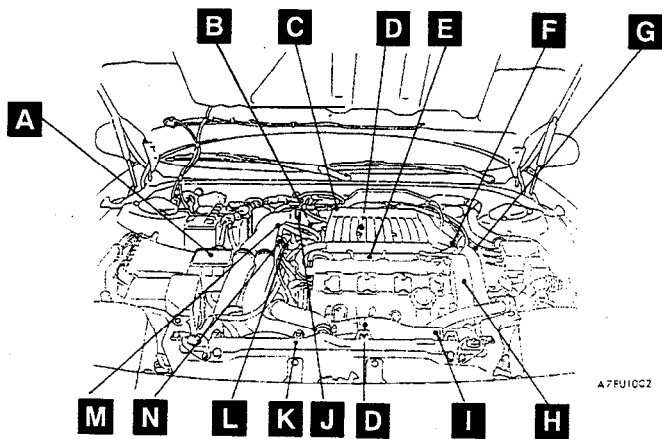

19F0134  
00004237

TSB Revision



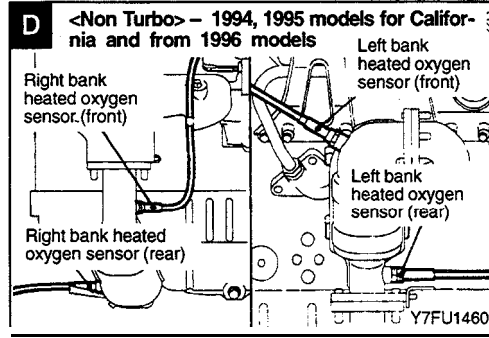
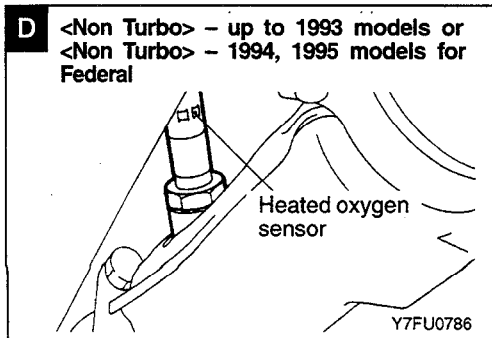
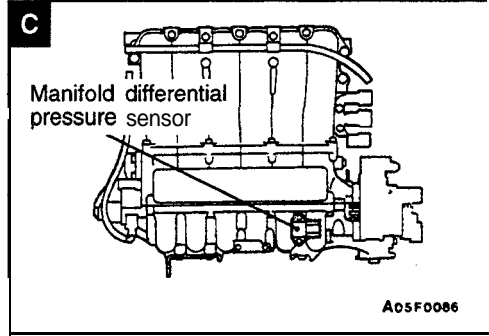
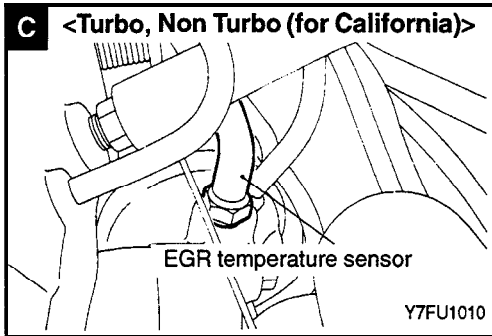
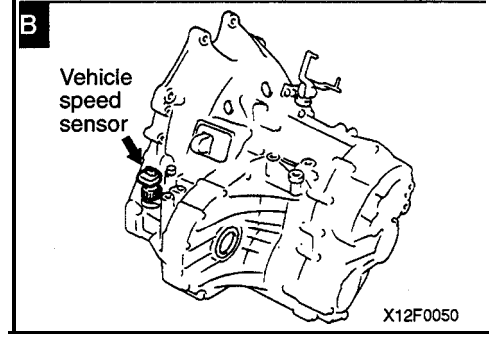
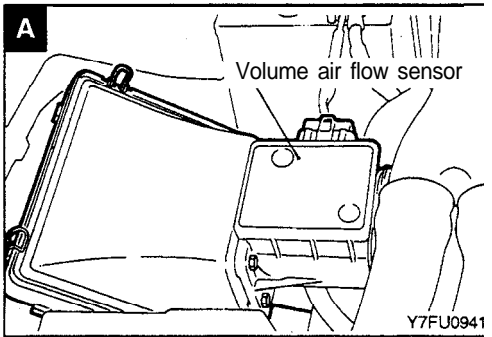
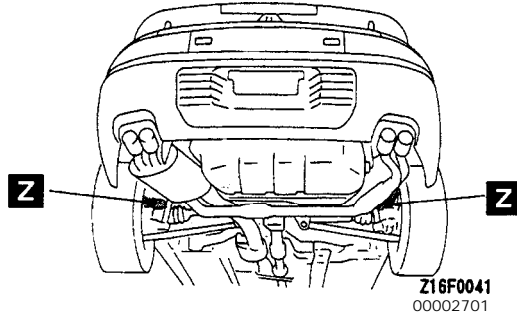
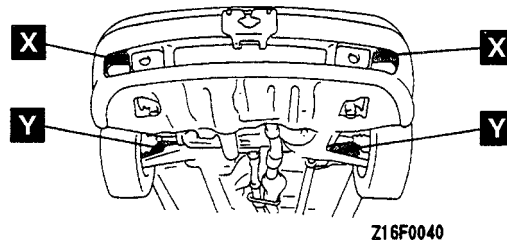
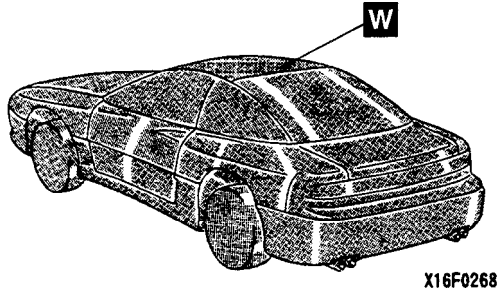

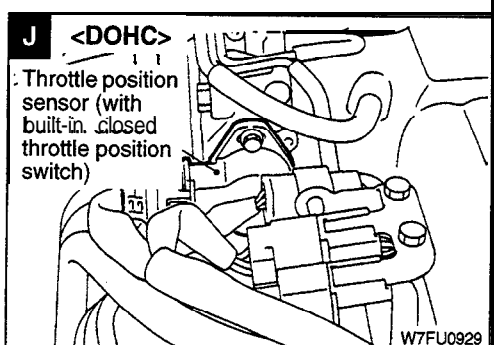
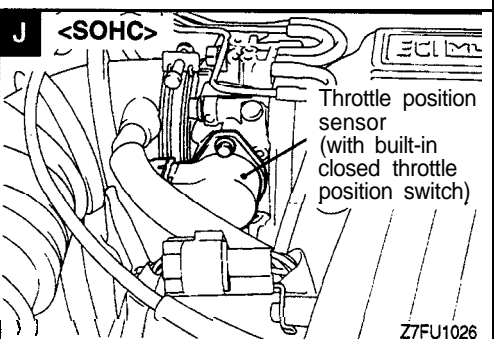
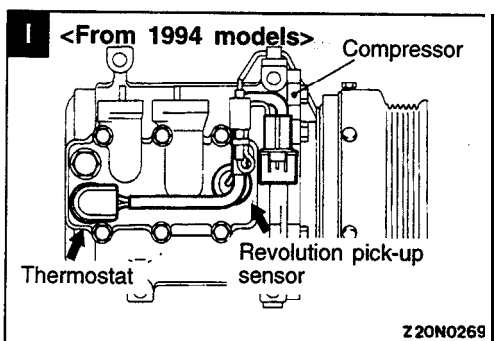
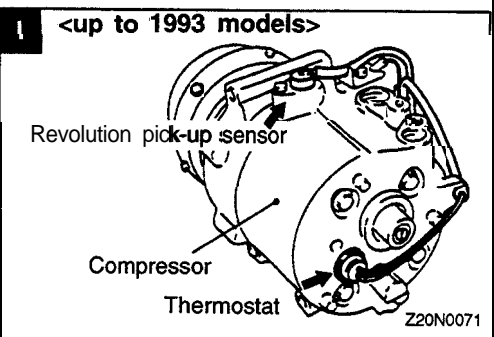
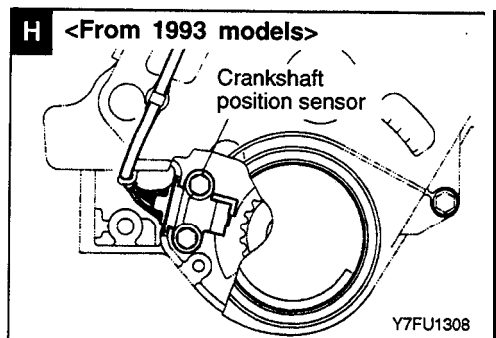
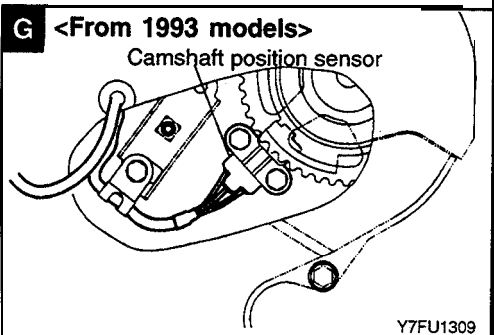
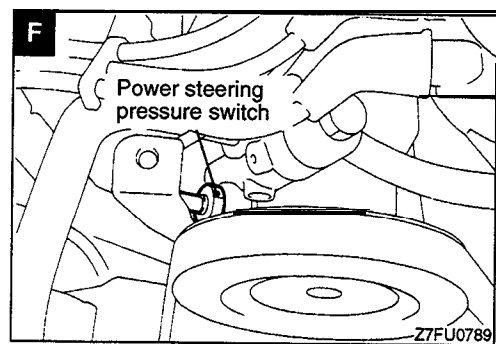
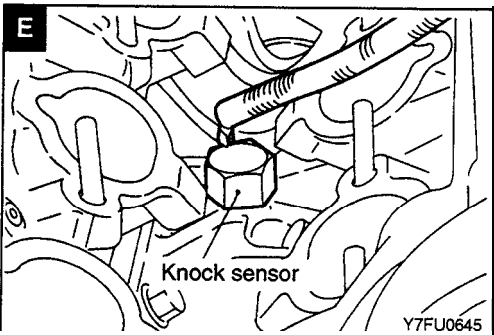
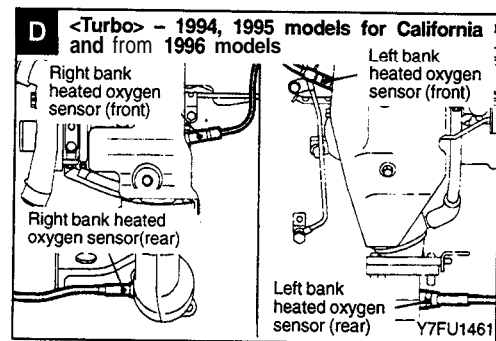
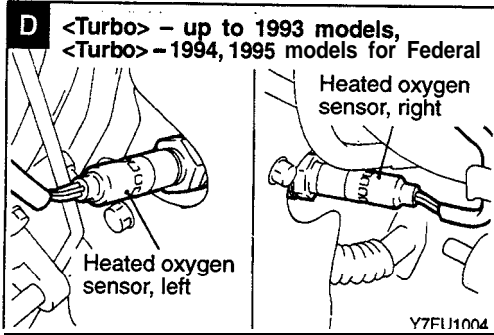

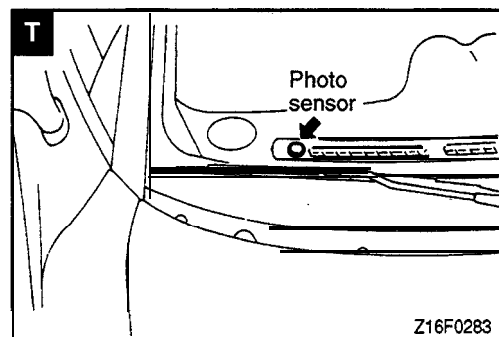
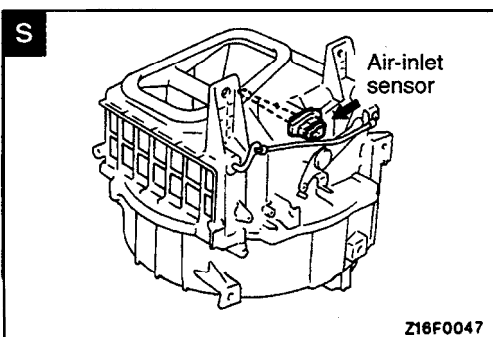
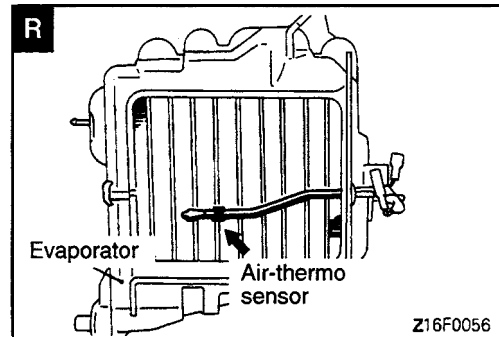
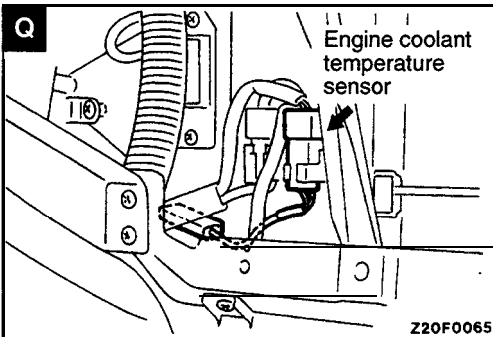
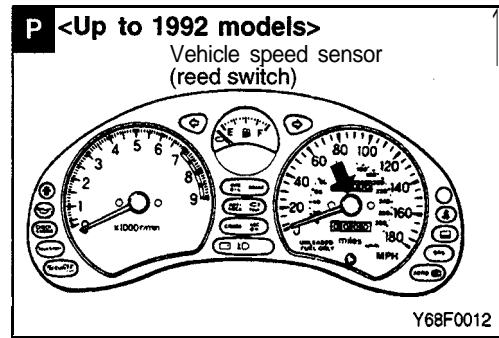
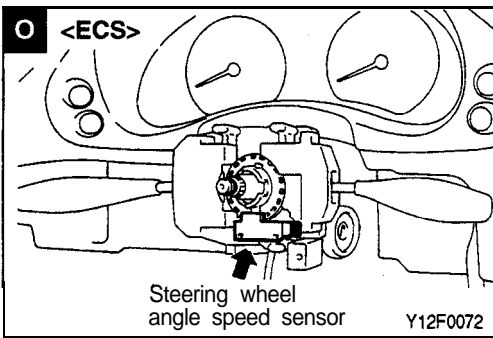
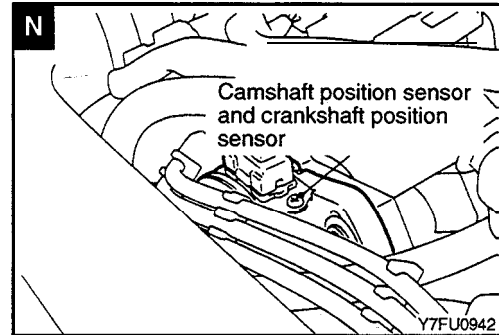
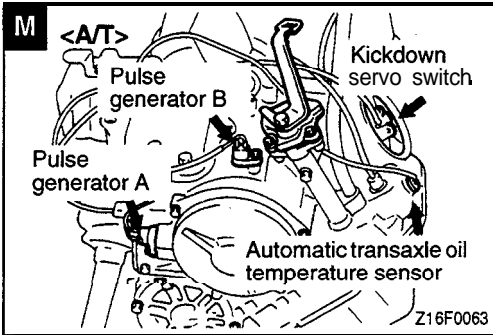
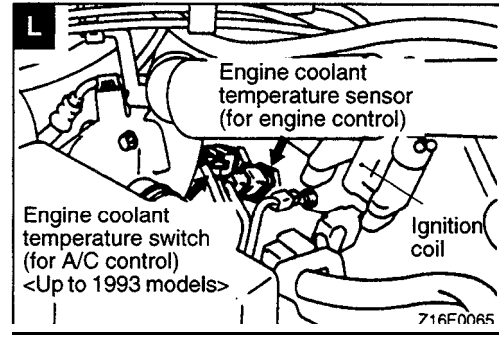
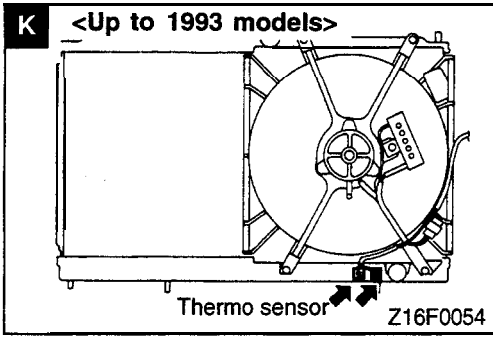



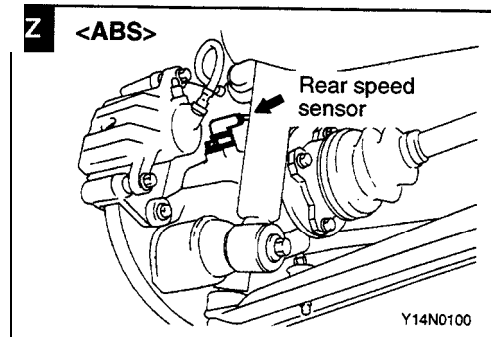
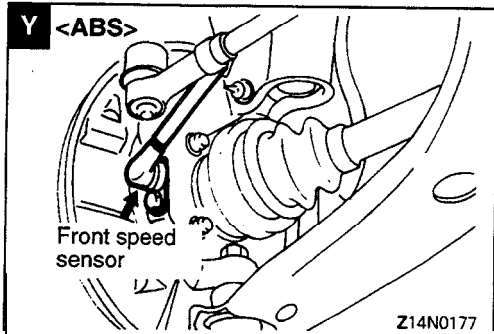
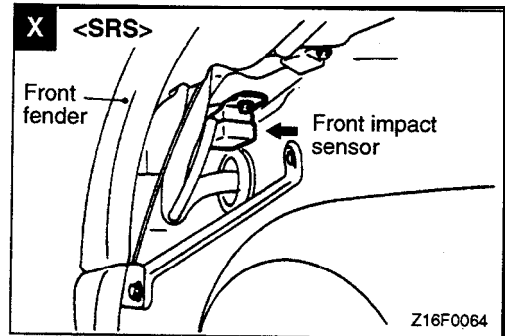
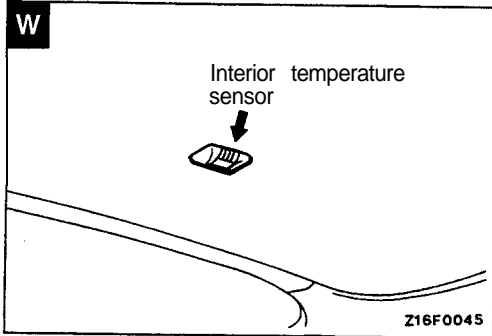
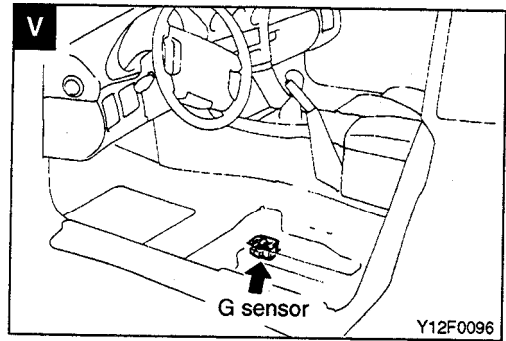
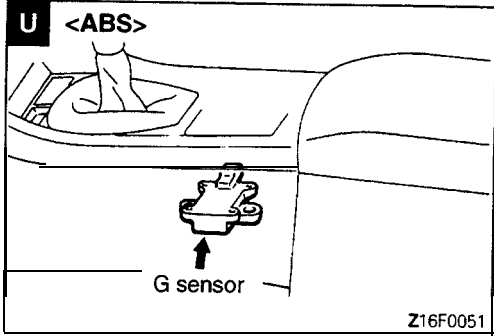

**CONTROL UNIT LOCATION**

Name	Symbol	Name	Symbol
ABS control unit	J	Engine control module	B
Active exhaust control module <Up to 1994 models>	H	ETACS control unit	A
Air conditioning compressor lock controller	C	Keyless entry control unit	F
Air conditioning control unit	B	Light automatic shut-off unit	F
Auto-cruise control unit	C	Motor antenna control unit	G
ELC-4 A/T control module	B	SRS diagnosis unit	D
Electronic control suspension control unit	I	Sunroof control unit	E

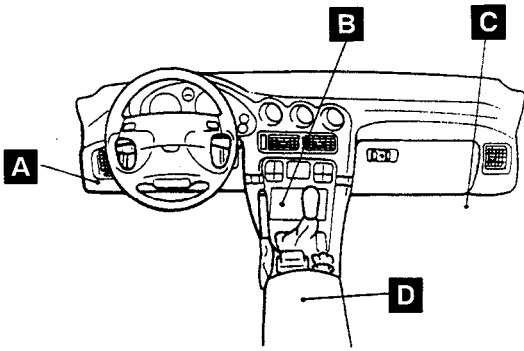

19F0134

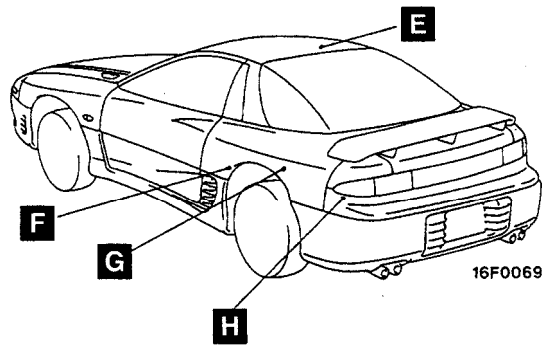

16F0069

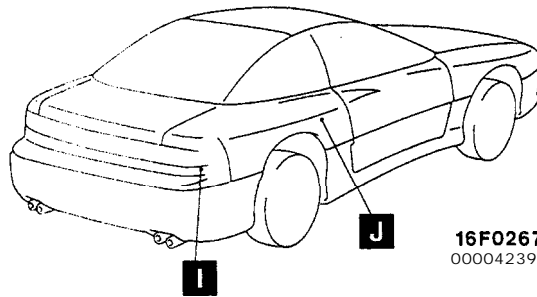

16F0267  
00004239

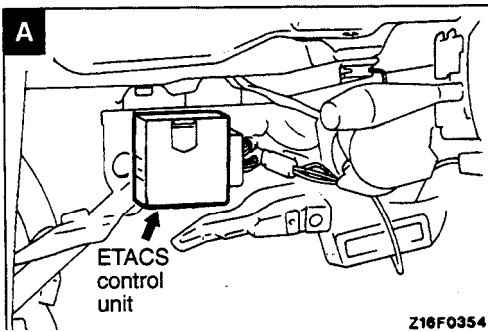

Z16F0354

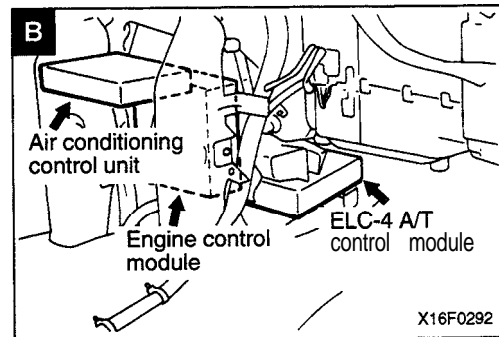

X16F0292

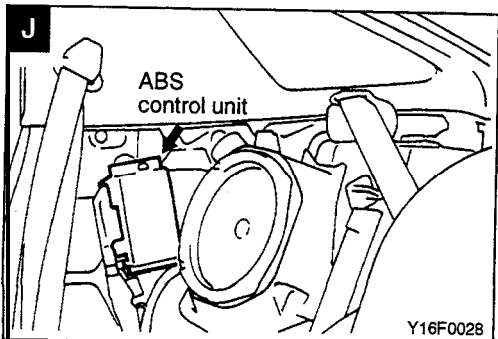
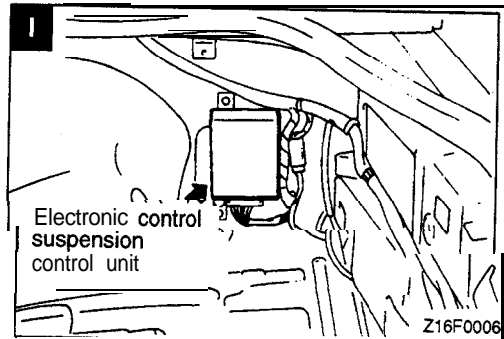
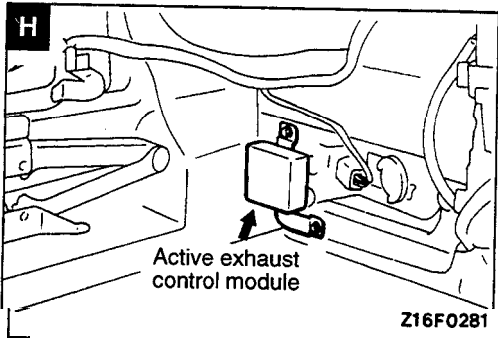
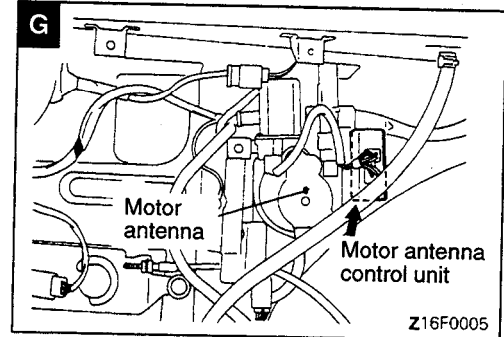
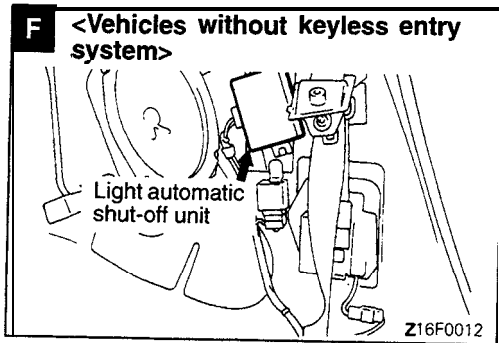
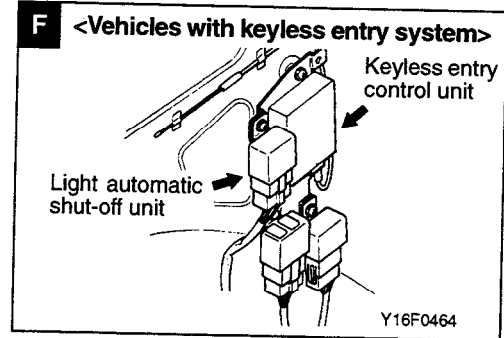
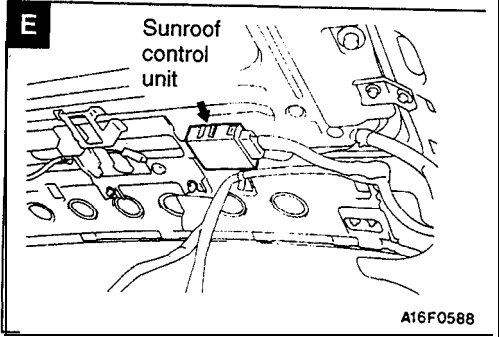
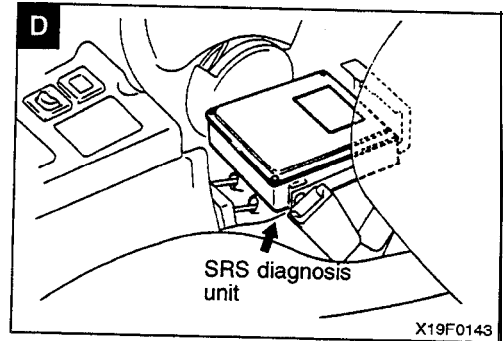
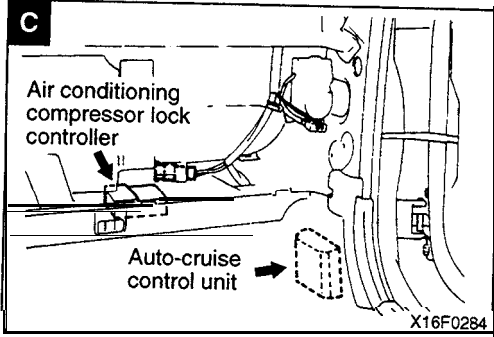



# SOLENOID, SOLENOID VALVE LOCATION

Name	Symbol	Name	Symbol
EGR solenoid <Turbo> <Non Turbo (Up to 1995 models for California and from 1996 models)>	C	Fuel pressure solenoid <Turbo>	A
Evaporative emission purge solenoid	B	Turbocharger waste gate solenoid <Turbo>	D

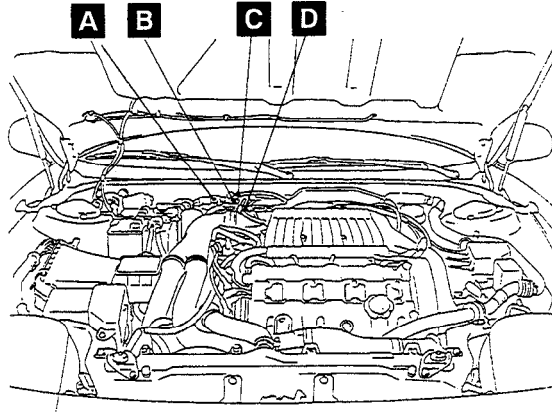

X7FU1002

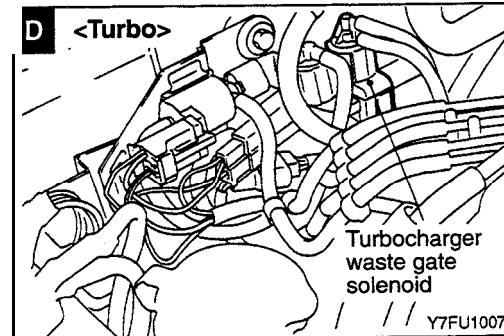
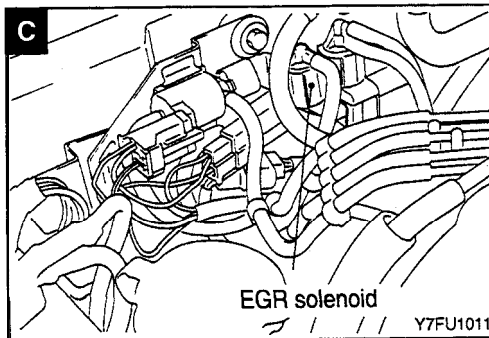
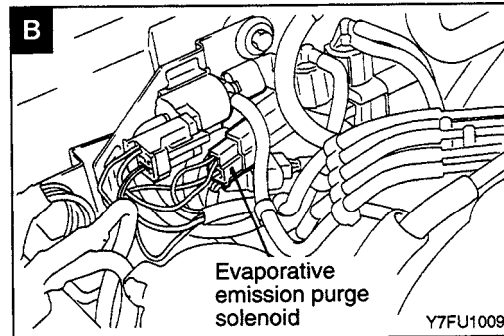
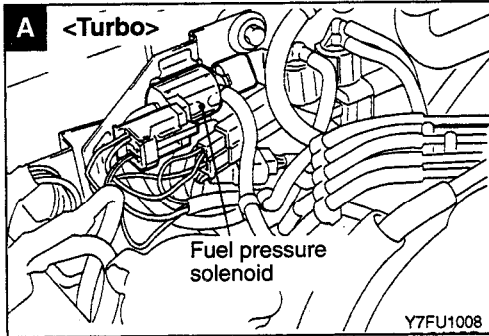

**DIODE LOCATION**

Name	Symbol	Name	Symbol
Diode (ABS circuit) <Up to 1995 models>	A	Diode (Theft-alarm circuit)	C
Diode (MFI circuit)	B	Diode (4WS fluid level warning light circuit)	D
Diode (Seat belt warning circuit)	C		

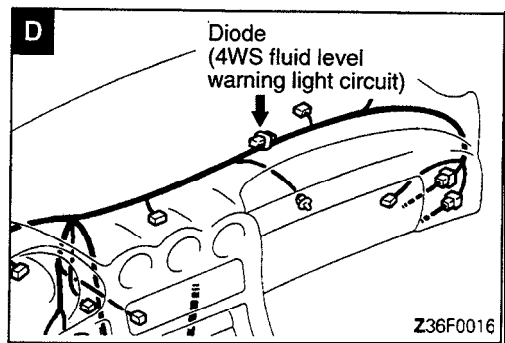
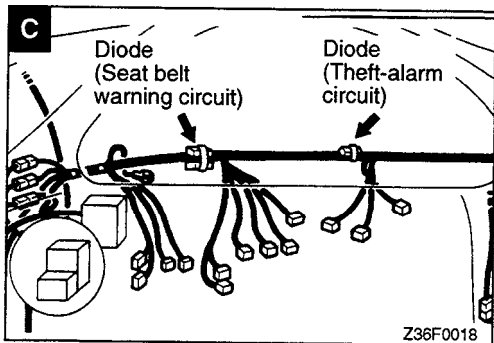
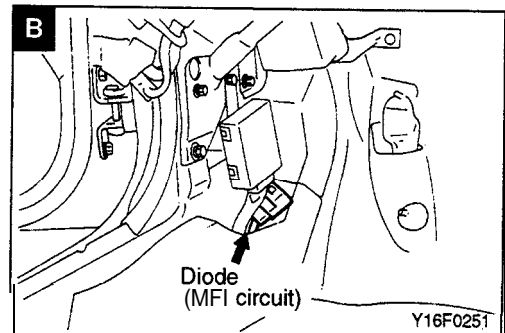
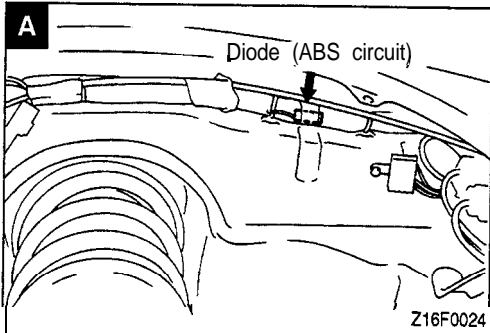
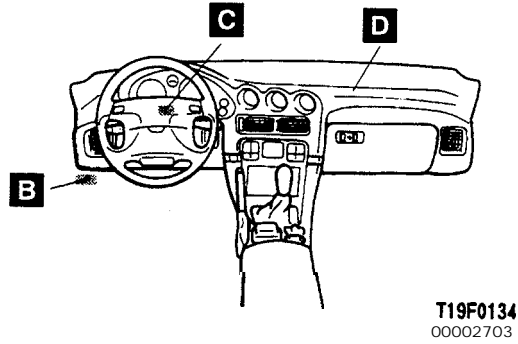
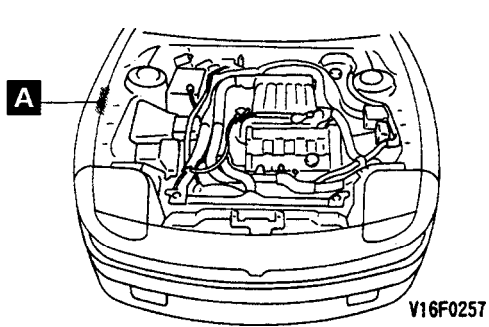

JUNCTION BLOCK

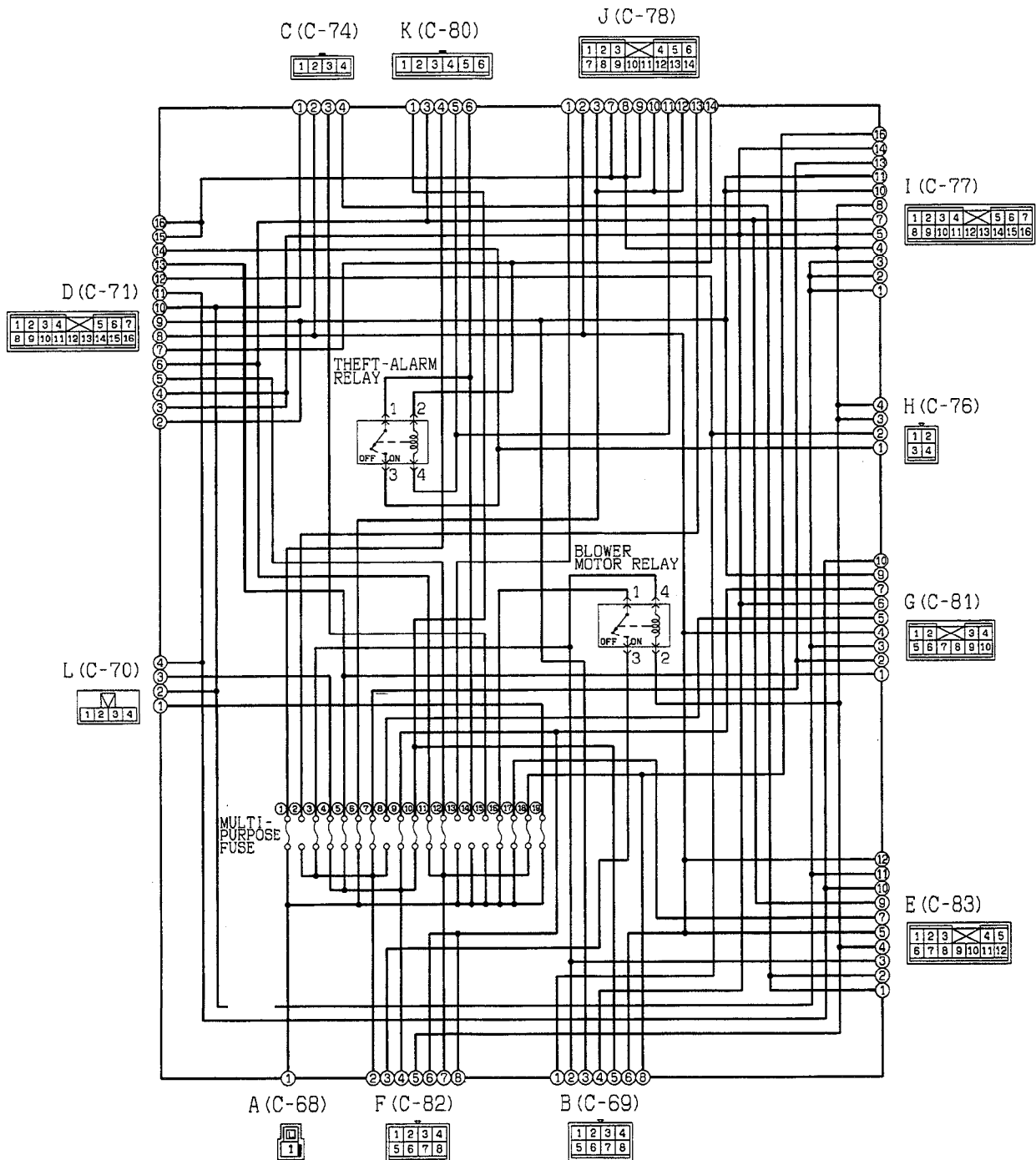

HROOM00AA

Remarks

- (1) Alphabets assigned to the connectors are keyed to those assigned to connectors on P.19
- (2) Terminals of the harness side connector are indicated in parentheses ( ).

TSB Revision

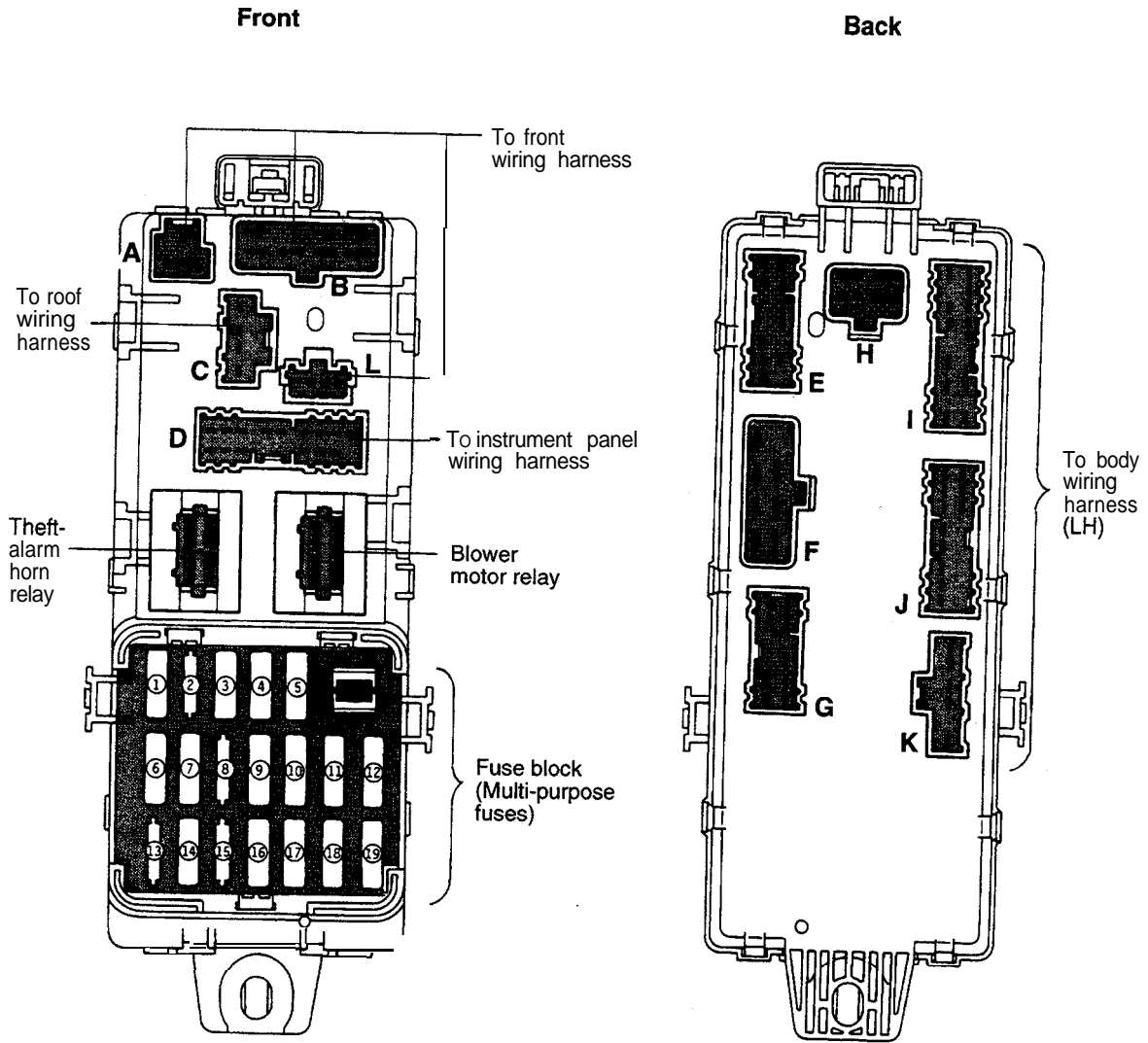

Z16F0304

Z16F0058  
00002704



**CENTRALIZED JUNCTION**

**FUSIBLE LINK (Relay box in engine compartment)**

No.	Circuit	Housing color	Rated capacity (A)
1	Generator circuit	Wine red	120
2	Pop-up motor circuit (Up to 1993 models)	Pink	30
3	Lighting circuit	Green	40
4	Ignition switch circuit	Pink	30
5	Radiator fan motor and condenser fan motor circuit	Green	40
6	Junction block (Multipurpose fuse (1),(6),(14),(16),(17), (19))	Green	40
7	ABS circuit	Yellow	60
8	Top stack circuit <Convertible>	Pink	30
9	Power window circuit	Pink	30
10	Defogger circuit	Green	40
11	Active aero circuit <Hatchback>	Pink	30

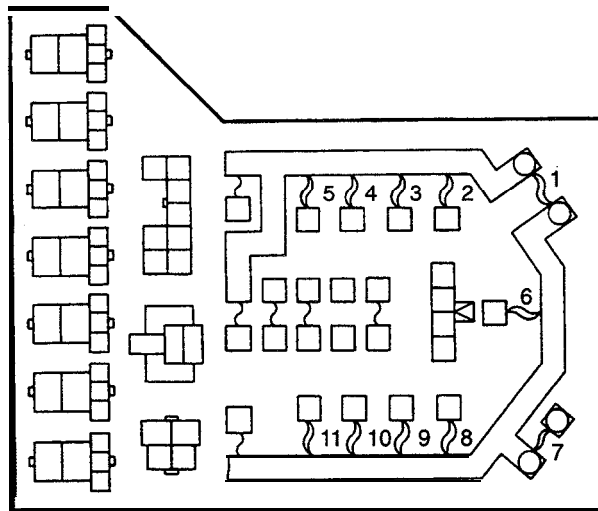

W16F0256

**DEDICATED FUSE**

Power supply circuit	No.	Rated capacity (A)	Housing color	Circuit
Battery	1	20	Yellow	MFI circuit
Taillight relay	2	15	Blue	Taillight circuit
Fusible link (6)	3	10	Red	Horn circuit
Fusible link (3)	4	15	Red	Fog light circuit
Headlight relay	5	10	Red	Upper beam circuit
Battery	6	10	Red	Hazard light circuit
	7*1	10	Red	ABS circuit
	7*2	20	Yellow	Sunroof circuit
Fusible link (6)	a	20	Yellow	Condenser fan motor circuit
	9	10	Red	Air conditioning circuit
Defogger relay	10	10	Red	Remote controlled mirror heater circuit

**NOTE**

\*1: Vehicles produced up to Oct. 1993.

\*2: Vehicles with sunroof

**<Relay box in engine compartment>**

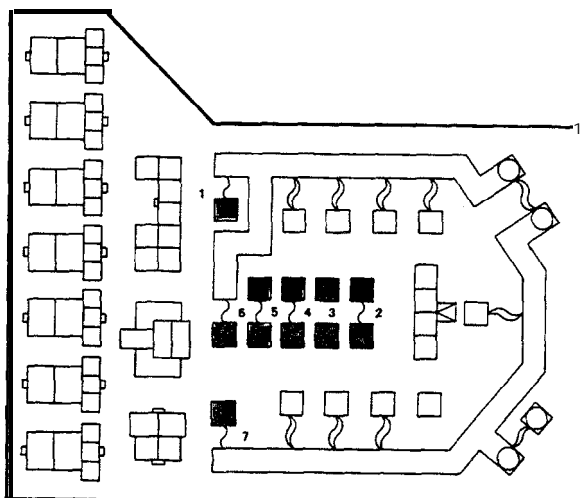

Z16F0256

**<Air conditioning relay box in engine compartment>**

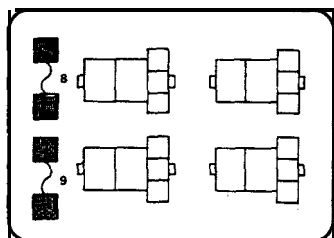

Z16F0002

**<Interior relay box>**

Up to 1993 models From 1994 models

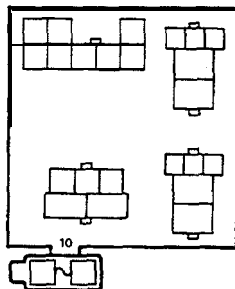

Z16F0003

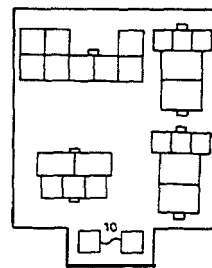

Z16F0431  
00002705

## MULTI-PURPOSE FUSE (In junction block)

Power supply circuit	No.	Rated capacity (A)	Load circuit	
Battery	1	10	Seat belt solenoid, Active aero control unit, MFI relay	
–	2	–	–	
Ignition switch	IG <sub>2</sub>	3	10	Radiator fan motor relay, Air conditioning compressor lock controller, Blower motor relay, Air conditioning control unit, ABS relay* <sup>1</sup> , ECS control unit* <sup>3</sup> , Condenser fan motor relay
	ACC	4	10	Audio, Motor antenna control unit, Auto-cruise control unit, ETACS unit
		5	15	Remote controlled mirror, Cigarette lighter
Battery	6	10	Door lock power relay, Motor antenna control unit	
Ignition switch IG <sub>2</sub>	7	10	ELC-4A/T control module	
–	8	–	–	
Ignition switch	ACC	9	15	Wiper relay, Wiper motor, Washer motor, Rear intermittent wiper relay, keyless control unit
		10	15	Accessory socket, ETACS unit
	IG <sub>1</sub>	11	15	Combination meter, Combination gauge, ETACS unit, Speed sensor, Motor antenna control unit, Turn signal and hazard flasher unit, Auto-cruise control main switch, Active aero control unit, SRS diagnosis unit, Auto-cruise relay
		12	15	Ignition coil, Power transistor, MFI relay, Engine control module
Battery	13* <sup>2</sup>	15	Amplifier <radio and tape player>	
Battery	14	10	Theft-alarm horn, Theft-alarm horn relay	
–	15	–	–	
Battery	16	30	Blower motor	
	17	15	Stop light, High-mounted stop light	
Ignition switch IG <sub>1</sub>	18	10	Back-up light, Light automatic shut-OFF unit, SRS diagnosis unit	
Battery	19	10	Engine control module, ELC-4 A/T control module, ETACS unit, Dome light, Foot light, Door light, Luggage compartment light, Combination meter, Ignition key cylinder illumination light, Air conditioning control unit, Auto-cruise control unit, Audio, Light automatic shut-OFF unit, ECS control unit* <sup>3</sup> , Active aero control unit	

## NOTE

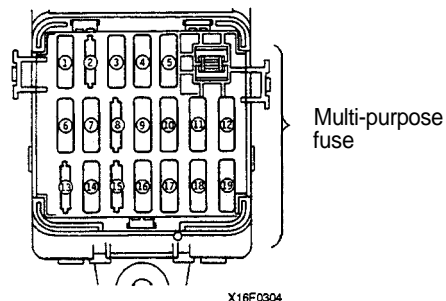
(1)\*<sup>1</sup>: Vehicles produced up to Oct. 1993.(2)\*<sup>2</sup>: From 1994 models.(3)\*<sup>3</sup>: Up to 1995 models.

**CENTRALIZED RELAY**

Classification		Name	Classification		Name
Relay box in engine compartment	A-01X	Headlight relay	Air conditioning relay box in engine compartment	A-31X	Condenser fan motor relay (HI)
	A-02X	ABS power relay (vehicles produced up to Oct. 1993)		A-32X	Radiator fan motor control relay (Up to 1993 models)
	A-03X	Fog light relay		A-33X	Magnetic clutch relay
	A-04X	Radiator fan motor relay (LO)		A-34X	Condenser fan motor relay (LO)
	A-05X	Taillight relay	Interior relay box	C-04X	Door lock power relay 1
	A-06X	Horn relay		C-05X	Defogger relay (1994 models)
	A-07X	Radiator fan motor relay (HI)		C-06X	Defogger relay (Up to 1993 models, From 1995 models)
	A-08X	Pop-up motor relay (Up to 1993 models)		C-07X	Power window relay
	A-09X	Starter relay			
	A-10X	Generator relay			
	A-11X	IOD or Storage connector			

NOTE  
IOD: Ignition Off Draw

<Relay box in engine compartment>

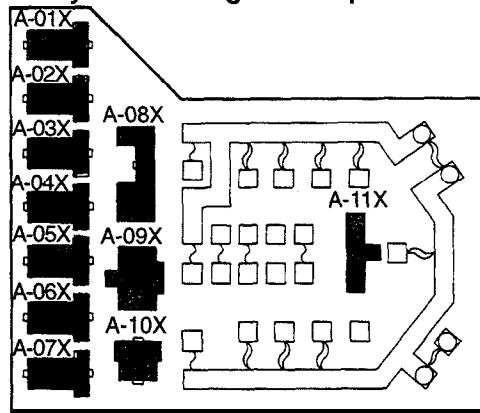

Y16F0256

<Air conditioning relay box in engine compartment>

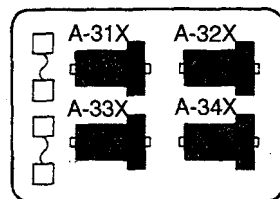

Y16F0002

<Interior relay box>

Up to 1993 models      From 1994 models

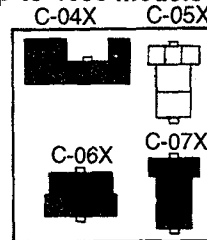

Y16F0003

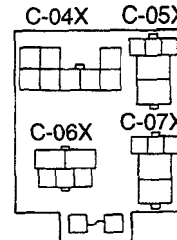

Y16F0431  
00002706



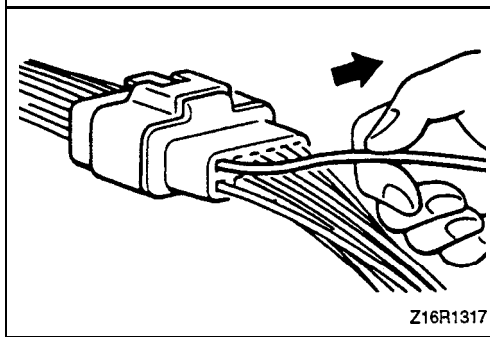
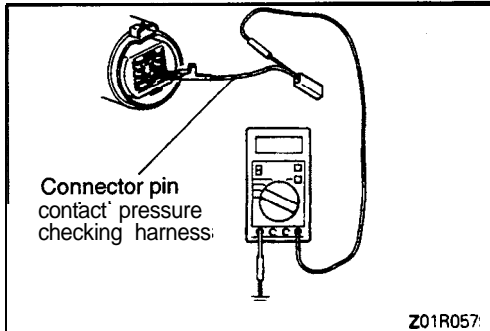
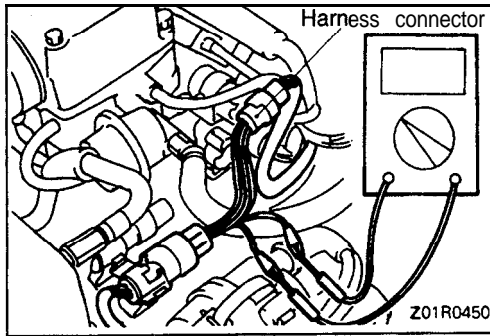

## HARNESS CONNECTOR INSPECTION

### CONNECTOR CONTINUITY AND VOLTAGE TEST

When checking continuity and/or voltage at the waterproof connectors, follow the steps below to avoid poor connector contact and/or reduced waterproof performance of connectors.

- (1) When checking is performed with the circuit in the state of continuity, be sure to use the special tool (harness connector).

Never insert a test bar from the harness side, because to do so will reduce the waterproof performance and result in corrosion.

- (2) When the connector is disconnected for checking the female pin, the harness for checking the contact pressure of connector pins should be used.

Never force the insertion of a test bar, because to do so will cause poor contact.

- (3) When the male pin is to be checked, apply the test bar against the pin directly.

Care must be taken not to short-circuit the connector pins.

### TERMINAL ENGAGEMENT CHECK

When the terminal stopper of connector is out of order, engagement of male and female terminals becomes improper even when the connector itself is engaged perfectly and the terminal sometimes slips out to the rear side of connector. Ascertain, therefore, that each terminal does not come off the connector by pulling each harness wire.

### CONNECTOR TERMINAL ENGAGEMENT AND DISENGAGEMENT

Connectors which are loose shall be rectified by removing the female terminal from connector housing and raising its lance to establish a more secure engagement. Removal of connector terminal used for MFI and 4 A/T control circuit shall be done in the following manner.

### COMPUTER CONNECTOR

- (1) Insert screwdriver [1.4 mm (.06 in.) width] as shown in the figure, disengage front holder and remove it.

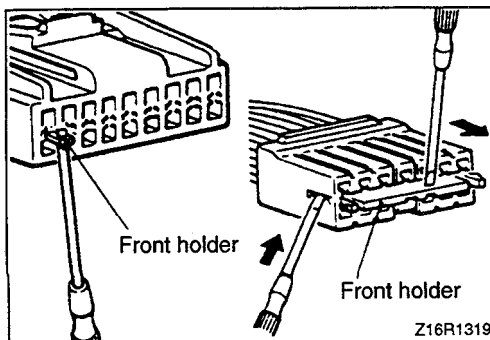

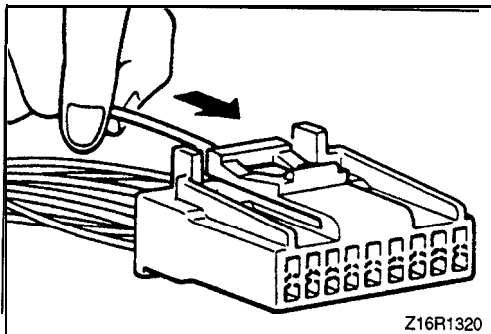

- (2) Insert harness of terminal to be rectified deep into connector from harness side and hold it there.

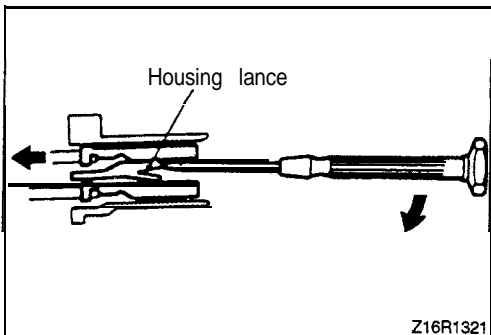

- (3) Insert tip of screwdriver [1.4 mm (.06 in.) width] into connector in a manner as shown in the figure, raise housing lance slightly with it and pull out harness.

**Caution**

**Tool No. 753787-I supplied by AMP can be used instead of screwdriver.**

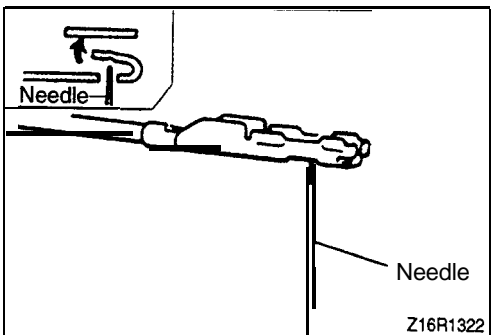

- (4) Insert needle through a hole provided on terminal and raise contact point of male terminal.

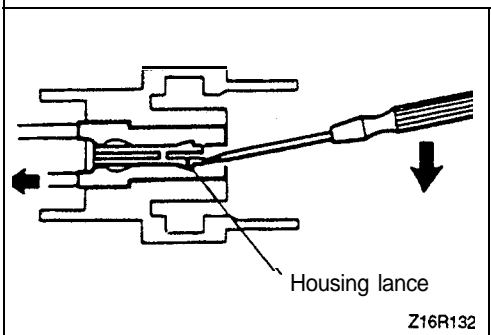

**ROUND WATERPROOF CONNECTOR**

- (1) Remove waterproof cap by using a screwdriver.
- (2) Insert tip of screwdriver [1.4 mm (.06 in.) or 2.0 mm (.08 in.) width] into connector in a manner as shown in the figure, raise housing lance slightly with it and pull out harness.

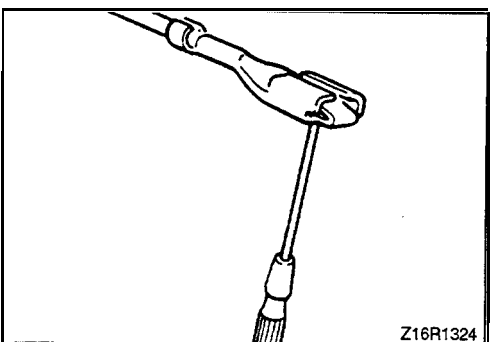

- (3) Insert screwdriver through a hole provided on terminal and raise contact point of male terminal.

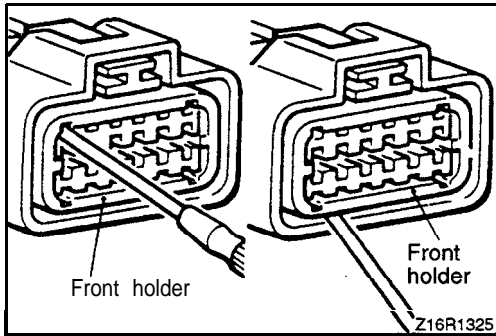

**RECTANGULAR WATERPROOF CONNECTOR**

- (1) Disengage front holder by using a screwdriver and remove it.

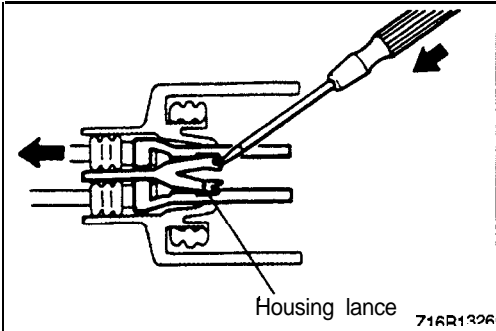

- (2) Inset-t tip of screwdriver [\*0.8 mm (.03 in.) width] into connector in a manner as shown in the figure, push it lightly to raise housing lance and pull out harness.  
\*If right size screwdriver is not available, convert a conventional driver to suit the size.

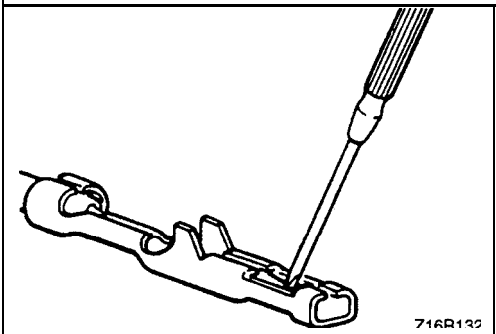

- (3) Press contact point of male terminal down by holding a screwdriver [1.4 mm (.06 in.) width] in a manner as shown in the figure.

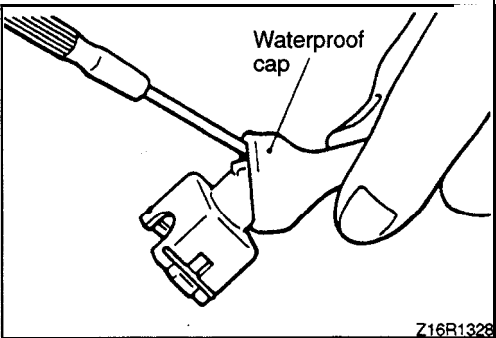

**INJECTOR CONNECTOR**

- (1) Remove waterproof cap.

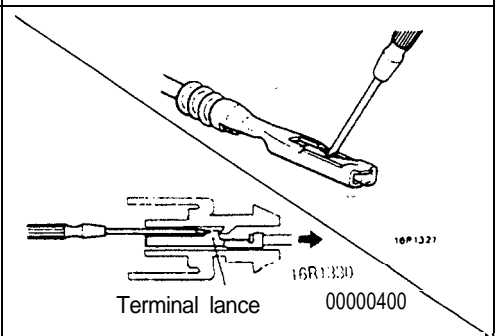

- (2) Insert tip of screwdriver [1.4 mm (.06 in.) width] into connector in a manner as shown in the figure, press in terminal lance and pull out harness.
- (3) Press contact point of male terminal down by holding a screwdriver [1.4 mm (.06 in.) width] in a manner as shown in the figure.

**Caution**

**Make sure that lance is in proper condition before terminal is inserted into connector.**

## HOW TO DIAGNOSE

The most important point in troubleshooting is to determine "Probable Causes". Once the probable causes are determined, parts to be checked can be limited to those associated with such probable causes. Therefore, unnecessary checks can be eliminated. The determination of the probable causes must be based on a theory and be supported by facts and must not be based on intuition only.

### TROUBLESHOOTING STEPS

If an attempt is made to solve a problem without going through correct steps for troubleshooting, the problem symptoms could become more complicated, resulting in failure to determine the causes correctly and making incorrect repairs. The four steps below should be followed in troubleshooting.

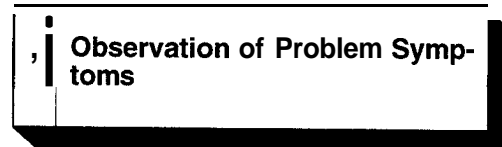

Observe the symptom carefully.  
Check if there are also other problems.

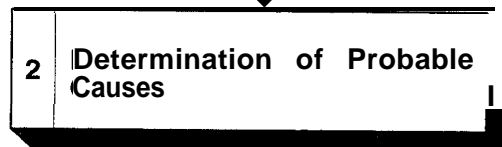

In determining the probable causes, it is necessary to check the wiring diagram to understand the circuit as a system. Knowledge of switches, relays and other parts is necessary for accurate determination. The causes of similar problems in the past must be taken into account.

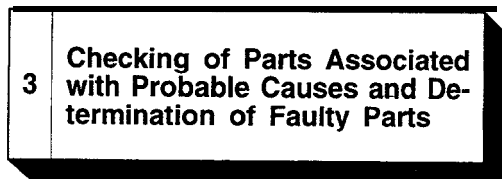

Troubleshooting is carried out by making step by step checks until the true cause is found. Always go through the procedures considering what check is to be made where for the best results.

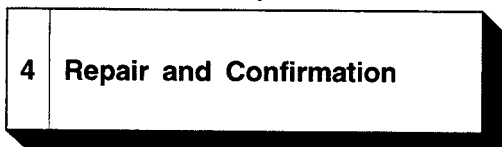

After the problems are corrected, be sure to check that the system operates correctly. Also, check that new problems have not been caused by the repair.

### INFORMATION FOR DIAGNOSIS

This manual contains the cable diagrams as well as the individual circuit drawings, operational explanations, and troubleshooting hints for each component required to facilitate the task of troubleshooting. The information is compiled in the following manner:

- (1) Cable diagrams show the connector positions, etc., on the actual vehicle as well as the harness path.
- (2) Circuit drawings show the configuration of the circuit with all switches in their normal positions.
- (3) Operational explanations include circuit drawings of voltage flow when the switch is operated and how the component operates in reaction.
- (4) Troubleshooting hints include numerous examples of problems which might occur, traced backward in a common-sense manner to the origin of the trouble.

Problems whose origins may not be found in this manner are pursued through the various system circuits.

#### NOTE

Components of MFI, ETACS, ECS, etc. with ECU do not include 3 and 4 above. For this information, refer to a manual which includes details of these components.

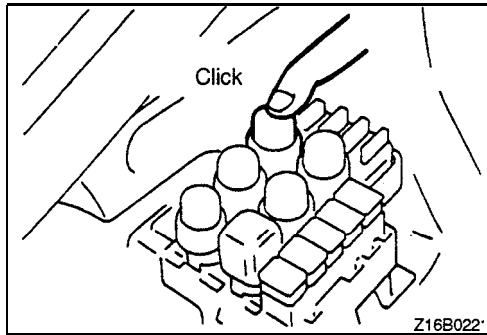

## INSPECTION

### 1. Visual and aural checks

Check relay operation, blower motor rotation, light illumination, etc. visually or aurally. The flow of current is invisible but can be checked by the operation of the parts.

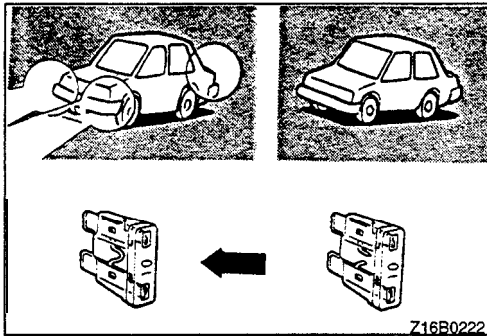

### 2. Simple checks

For example, if a headlight does not come on and a faulty fuse or poor grounding is suspected, replace the fuse with a new one or ground the light to the body by a jumper wire to determine which part is responsible for the problem.

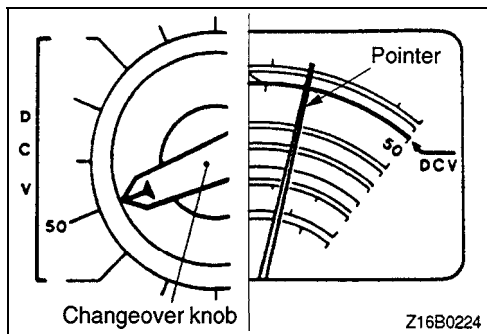

### 3. Checking with instruments

Use an appropriate instrument in an adequate range and read the indication correctly. You must have sufficient knowledge and experience to handle instruments correctly.

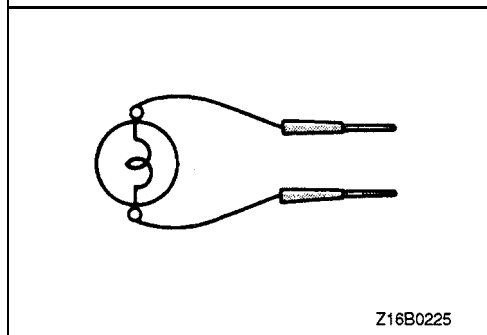

## INSPECTION INSTRUMENTS

In inspection, make use of the following instruments.

### 1. Test lights

A test light consists of a 12 V bulb and lead wires. It is used to check voltages or short circuits.

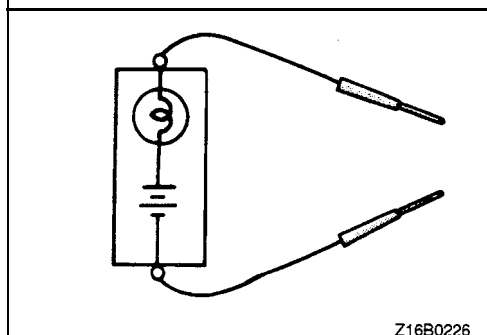

### 2. Self-power test light

A self-power test light consists of a bulb, battery and lead wires connected in series. It is used to check continuity or grounding.



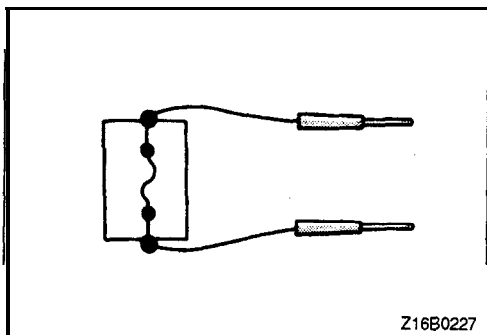

Z16B0227

**3. Jumper wire**

A jumper wire is used to close an open circuit. Never use one to connect a power supply directly to a load.

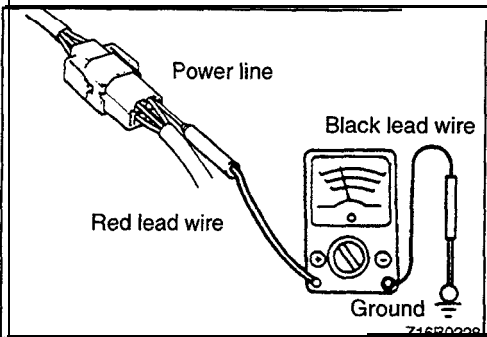

Z16B0228

**4. Voltmeter**

A voltmeter is used to measure the circuit voltage. Normally, the positive (red lead) probe is applied to the point of voltage measurement and the negative (black lead) probe to the body ground.

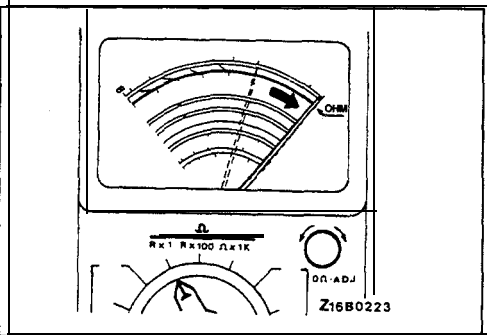

Z16B0223

**5. Ohmmeter**

An ohmmeter is used to check continuity or measure resistance of a switch or coil. If the measuring range has been changed, the zero point must be adjusted before measurement.

**CHECKING SWITCHES**

In a circuit diagram, a switch is represented by a symbol and in the idle state.

**1. Normal open or normal close switch**

Switches are classified into those which make the circuit open and those which make the circuit closed when off.

Normal open (NO) type	
OFF	ON
<p>Current does not flow</p> <p>16X0690</p>	<p>Current flows</p> <p>16X0691 00000401</p>
Normal close (NC) type	
OFF	ON
<p>Current flows</p> <p>16X0691</p>	<p>Current does not flow</p> <p>16X0690 00000402</p>

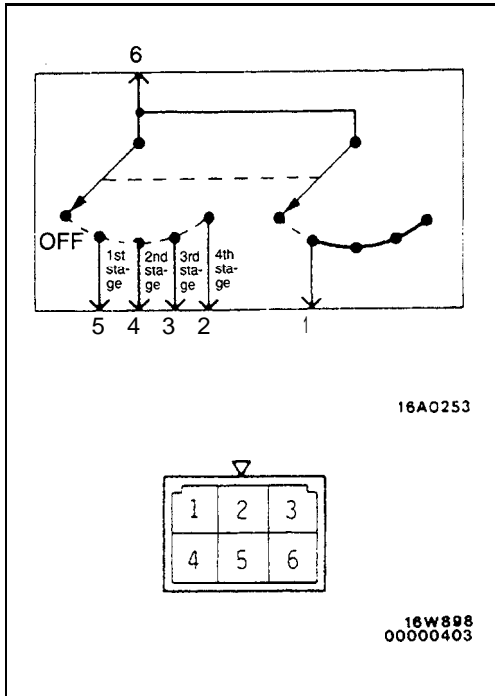

**2. SWITCH CONNECTION**

This figure illustrates a complex switch. The continuity between terminals at each position is as indicated in the table below.

Position	Terminal No.					
	1	2	3	4	5	6
OFF						
1st stage	○	—			○	○
2nd stage	○			○		○
3rd stage	○		○			○
4th stage	○	○				○

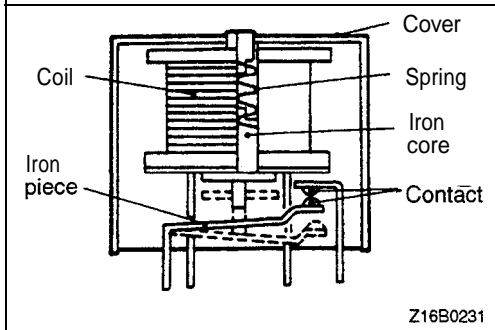

**CHECKING RELAYS**

1. When current flows through the coil of a relay, its core is magnetized to attract the iron piece, closing (ON) the contact at the tip of the iron piece. When the coil current is turned off, the iron piece is made to return to its original position by a spring, opening the contact (OFF).

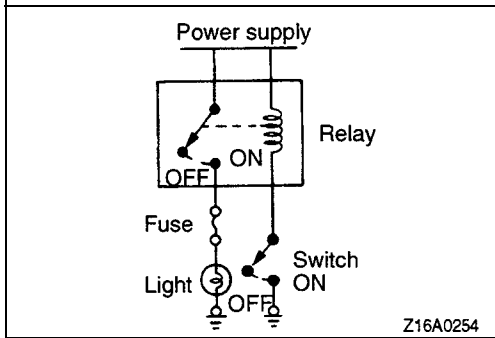

2. By using a relay, a heavy current can be turned on and off by a switch of small capacity. For example, in the circuit shown here, when the switch is turned on (closed), current flows to the coil of the relay. Then, its contact is turned on (closed) and the light comes on. The current flowing at this time to the switch is the relay coil current only and is very small.

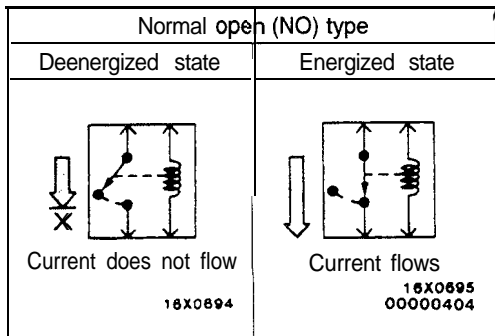

3. The relays may be classified into the normal open type and the normal close type by their contact construction.

**NOTE**

The deenergized state means that no current is flowing through the coil and the energized state means that current is flowing through the coil.

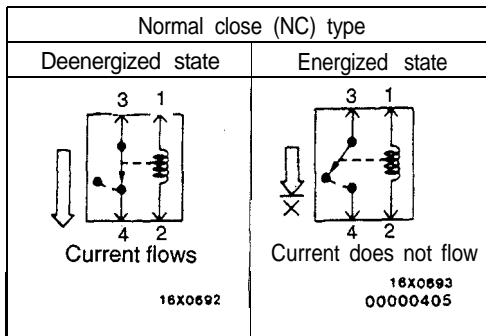

When a normal close type relay as illustrated here is checked, there should be continuity between terminals (1) and (2) and between terminals 3 and 4 when the relay is deenergized, and the continuity should be lost between terminals 3 and 4 when the battery voltage is applied to the terminals 1 and 2. A relay can be checked in this manner and it cannot be determined if a relay is okay or faulty by checking its state only when it is deenergized (or energized),

**CHECKING FUSES**

A blade type fuse has test taps provided to allow checking of the fuse itself without removing it from the fuse block. The fuse is okay if the test light comes on when its one lead is connected to the test taps (one at a time) and the other lead is grounded. (Change the ignition switch position adequately so that the fuse circuit becomes live.)

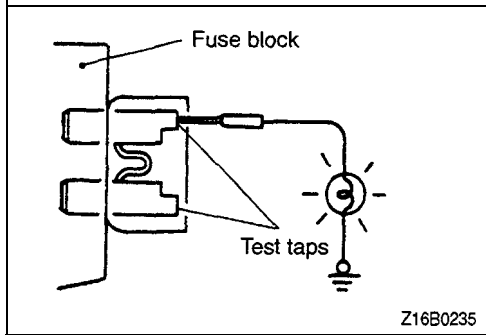

**CAUTIONS IN EVENT OF BLOWN FUSE**

When a fuse is blown, there are two probable causes as follows: One is that it is blown due to flow of current exceeding its rating.

The other is that it is blown due to repeated on/off current flowing through it. Which of the two causes is responsible can be easily determined by visual check as described below.

(1) Fuse blown due to current exceeding rating

The illustration shows the state of a fuse blown due to this cause. In this case, do not replace the fuse with a new one hastily since a current heavy enough to blow the fuse has flowed through it. First, check the circuit for shorting and check for abnormal electric parts. Only after the correction of such shorting or parts, fuse of the same capacity should be used as a replacement. Never use a fuse of larger capacity than the one that has blown. If such a fuse is used, electric parts or wirings could be damaged before the fuse blows in the event an overcurrent occurs again.

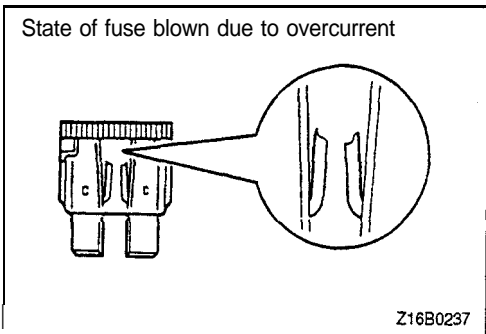

(2) Fuse blown due to repeated current on/off

The illustration shows the state of a fuse blown due to repeated current on/off. Normally, this type of problem occurs after fairly long period of use and hence is less frequent than the above type. In this case, you may simply replace with a new fuse of the same capacity.

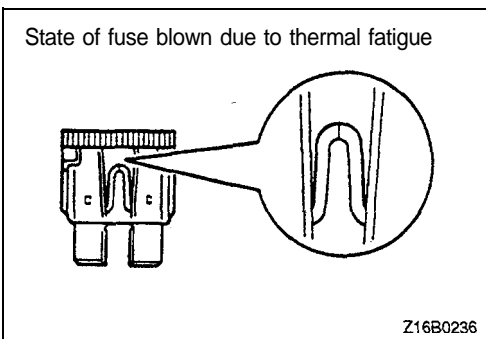

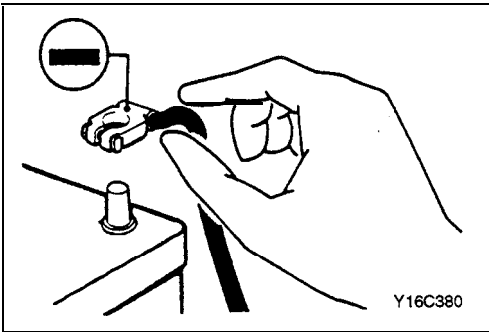
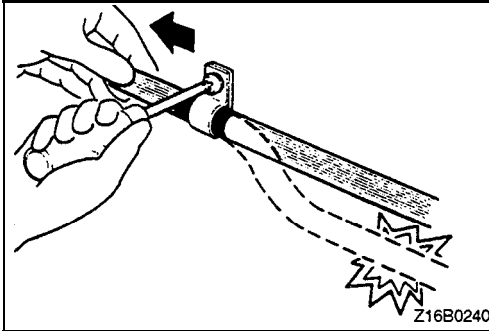
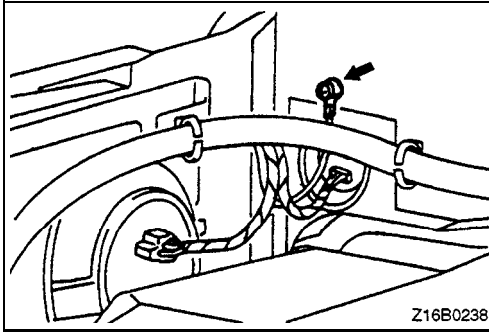

## CHECKING CABLES AND WIRES

1. Check connections for looseness, rust and stains.
2. Check terminals and wires for corrosion by battery electrolyte, etc.
3. Check terminals and wires for open circuit or impending open circuit.
4. Check wire insulation and coating for damage, cracks and degrading.
5. Check conductive parts of terminals for contact with other metallic parts (vehicle body and other parts).
6. Check grounding parts to verify that there is complete continuity between attaching bolt(s) and vehicle body.
7. Check for incorrect wiring.
8. Check that wirings are so clamped as to prevent contact with sharp corners of the vehicle body, etc. or hot parts (exhaust manifold, pipe, etc.).
9. Check that wirings are clamped firmly to secure enough clearance from the fan pulley, fan belt and other rotating or moving parts.
10. Check that the wirings between the fixed parts such as the vehicle body and the vibrating parts such as the engine are made with adequate allowance for vibrations.

## HANDLING ON-VEHICLE BATTERY

When checking or servicing does not require power from the on-vehicle battery, be sure to disconnect the cable from the battery (-) terminal. This is to prevent problems that could be caused by a short circuit. Disconnect the (-) terminal first and reconnect it last.

### Caution

1. **Before connecting or disconnecting the negative cable, be sure to turn off the ignition switch and the lighting switch.**  
(If this is not done, there is the possibility of semiconductor parts being damaged.)
2. **After completion of the work steps [when the battery's negative (-) terminal is connected], warm up the engine and allow it to idle for approximately five minutes under the conditions described below, in order to stabilize the engine control conditions, and then check to be sure that the idling is satisfactory.**

**Engine coolant temperature: 85–95°C (185–203°F)**

**Lights, electric fans, accessories: OFF**

**Transaxle: neutral position**

**(A/T models: "N" or "P")**

**Steering wheel: neutral (center) position**

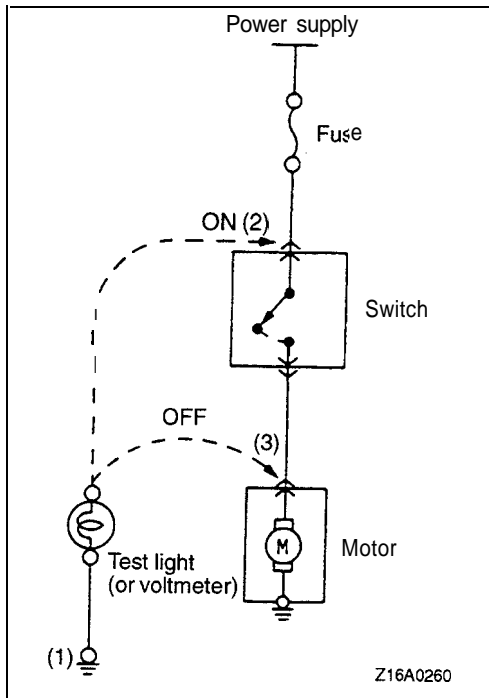

## GENERAL ELECTRICAL SYSTEM CHECKS

A circuit consists of the power supply, switch, relay, load, ground, etc. There are various methods to check a circuit including an overall check, voltage check, short circuit check and continuity check. Each of these methods is briefly described in the following.

### 1. VOLTAGE CHECK

- (1) Ground one lead wire of the test light. If a voltmeter is used instead of the test light, ground the grounding side lead wire.
- (2) Connect the other lead wire of the test light to the power side terminal of the switch connector. The test light should come on or the voltmeter should indicate a voltage.
- (3) Then, connect the test light or voltmeter to the motor connector. The test light should not come on, or the voltmeter should indicate no voltage. When the switch is turned on in this state, the test light should come on, or the voltmeter should indicate a voltage, with motor starting to run.
- (4) The circuit illustrated here is normal but if there is any problem such as the motor failing to run, check voltages beginning at the connector nearest to the motor until the faulty part is identified.

2. SHORT-CIRCUITS CHECK

A blown fuse indicates that a circuit is shorted. The circuit responsible can be determined by the following procedures.

Remove the blown fuse and connect a test light in its place  
(Switch is in the OFF position)

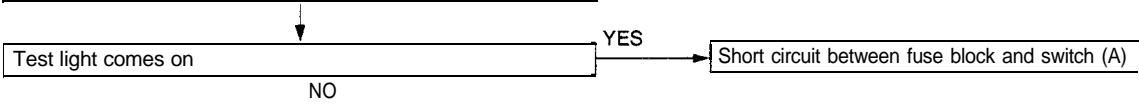

Turn on the switch  
(Test light comes on but the illumination light does not come on)

Disconnect the illumination light connector

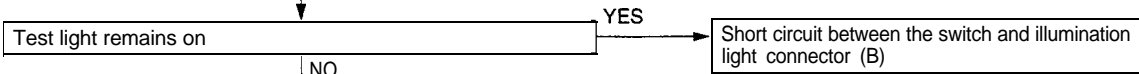

Short circuit between the illumination light connector and illumination light (C)

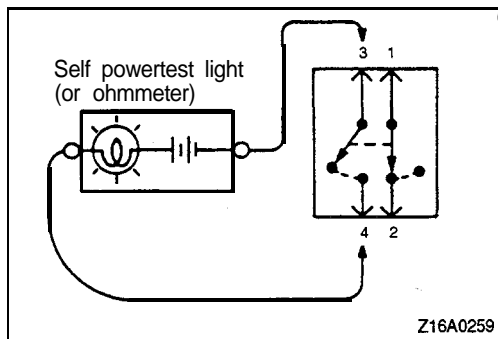
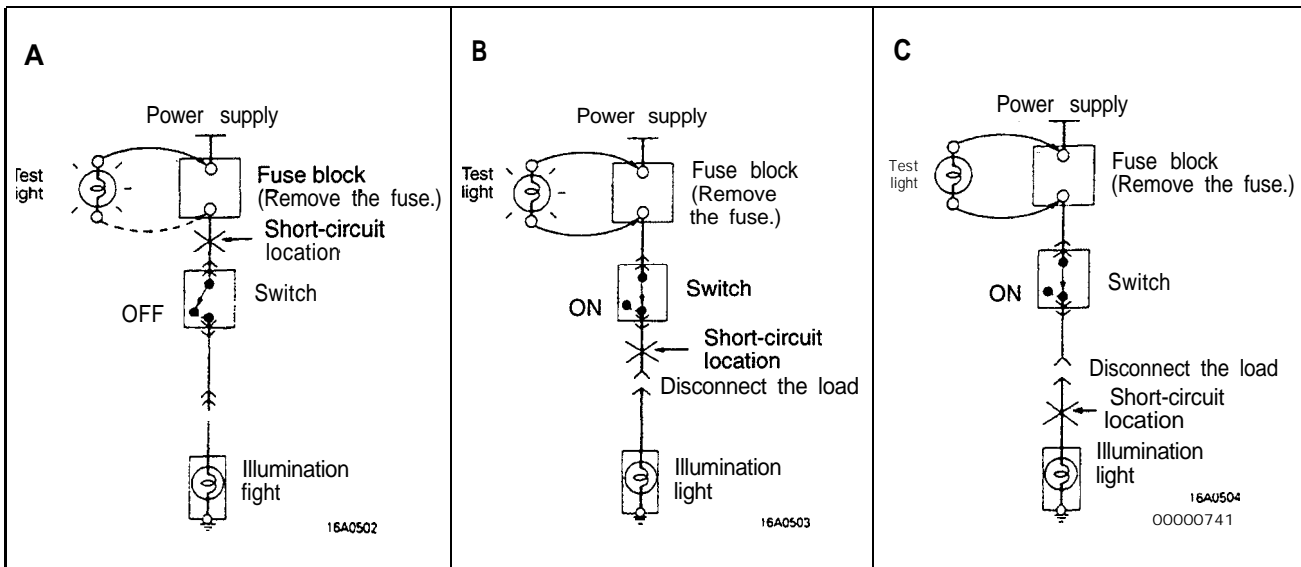

3. CONTINUITY CHECK

- (1) When the switch is in the OFF position, the self power test light should come on or the ohmmeter should read 0 ohm only when the terminals 1 and 2 are interconnected.
- (2) When the switch is in the ON position, the self power test light should come on or the ohmmeter should read 0 ohm only when the terminals 3 and 4 are interconnected.





# OVERALL CONFIGURATION DIAGRAM

<HATCHBACK>

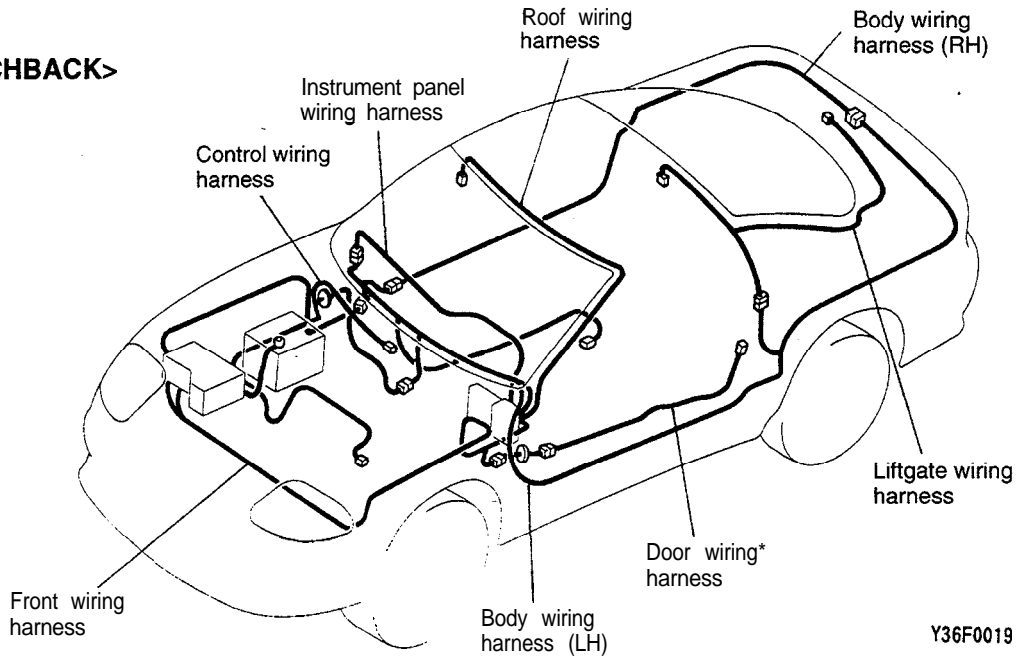

<CONVERTIBLE>

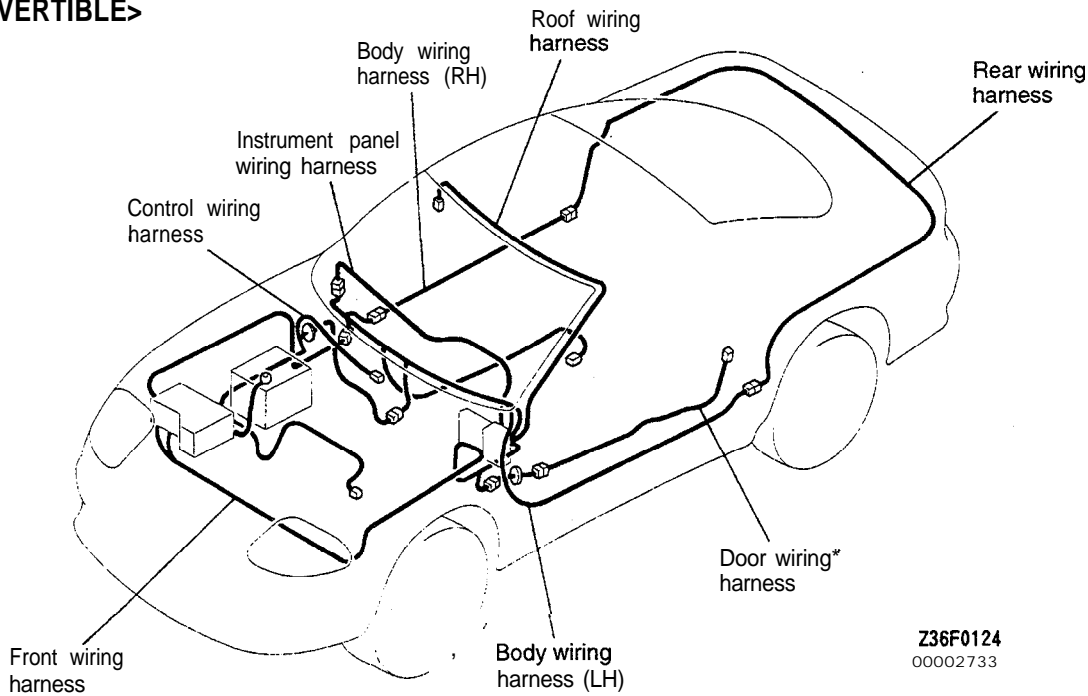

**NOTE**

- (1) This illustration shows only the major wiring harness.
- (2) \* indicates also equipped at the right side.

## HOW TO READ CONFIGURATION DIAGRAM

The wiring harness diagrams clearly show the connector locations and harness routings at each site on actual vehicles.

Denotes connector No.  
The same connector No. is used throughout the circuit diagrams to facilitate connector location searches. The first alphabetical symbol indicates the location site of the connector and a number that follows in the unique number. Numbers are assigned to parts in clockwise order on the diagram.

Example: A-1.2

Number specific to connector (serial number)  
Connector location site symbol  
A: Engine compartment  
B: Engine and transaxle  
C: Dash panel  
D: Instrument panel and floor console  
E: Interior  
F: Luggage compartment

Denotes ground point.  
Same ground number is used throughout circuit diagrams to facilitate search of ground point. Refer to P.4 for details of ground points.

The mark ★ shows the standard mounting position of wiring harness.

Denotes a section covered by a corrugated tube.

- A-01X
- A-02X
- A-03X
- A-04X
- A-05X
- A-06X
- A-07X
- A-08X
- A-09X
- A-10X
- A-11X

- A-12
- A-13
- A-14
- A-15
- A-16
- A-17
- A-18
- A-19
- A-20
- A-21

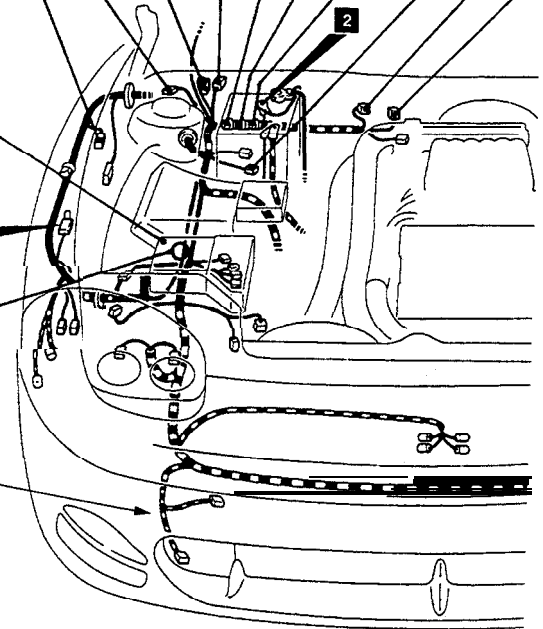

Z36F0122

- |                                     |   |
|-------------------------------------|---|
| A-01X Headlight relay               | A-18 ignition timing adjustment connector |
| A-02X ABS power relay               | A-19 Front washer motor                   |
| A-03X Fog light relay               | A-20 Evaporative emission purge solenoid  |
| A-04X Radiator fan motor relay(LO)  | A-21 EGR solenoid                         |
| A-05X Taillight relay               | (Vehicles for California)                 |
| A-06X Horn relay                    | A-22 EGR temperature sensor               |
| A-07X Radiator fan motor relay (HI) | (Vehicles for California)                 |
| A-09X Starter relay                 | A-23 No connection <Turbo>                |
| A-10X Generator relay               | A-24 Brake fluid level sensor             |
| A-11X IOD or Storage connector      | A-25 ECS front shock absorber (LH)        |
| A-12 ABS front speed sensor (RH)    | A-26 Theft-alarm horn                     |
| A-13 ECS front shock absorber (RH)  | A-27 Theft-alarm horn                     |
| A-14 Washer fluid level sensor      | A-28 Auto-cruise vacuum pump              |

**ENGINE COMPARTMENT  
(UP TO 1993 MODELS)**

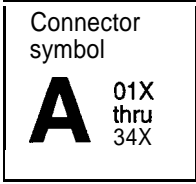

<Turbo>

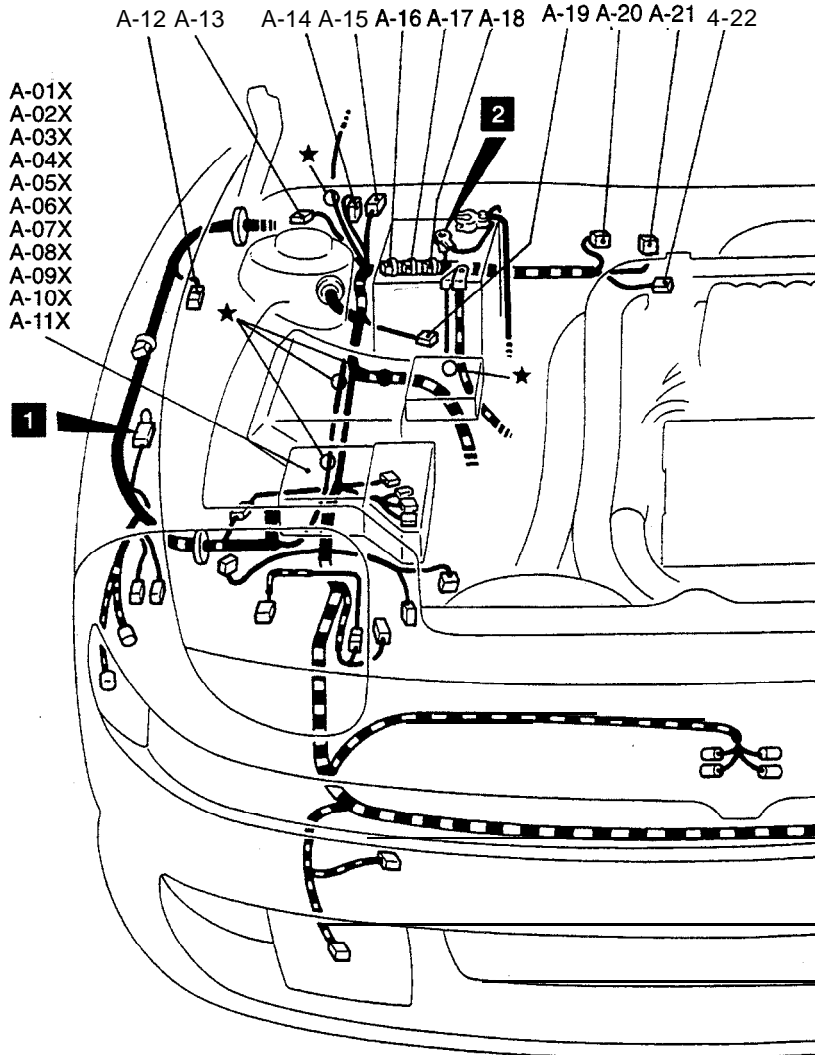
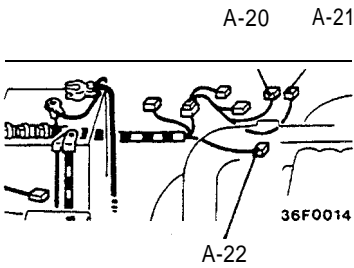

- A-01X Headlight relay
- A-02X ABS power relay
- A-03X Fog light relay
- A-04X Radiator fan motor relay (LO)
- A-05X Taillight relay
- A-06X Horn relay
- A-07X Radiator fan motor relay (HI)
- A-08X Pop-up motor relay
- A-09X Starter relay

- A-10X Generator relay
- A-11X IOD or Storage connector
- A-12 ABS front speed sensor (RH)
- A-13 ECS front shock absorber (RH)
- A-14 Washer fluid level sensor
- A-15 Front wiper motor
- A-16 Engine speed detection connector
- A-17 Fuel pump check connector
- A-18 Ignition timing adjustment connector

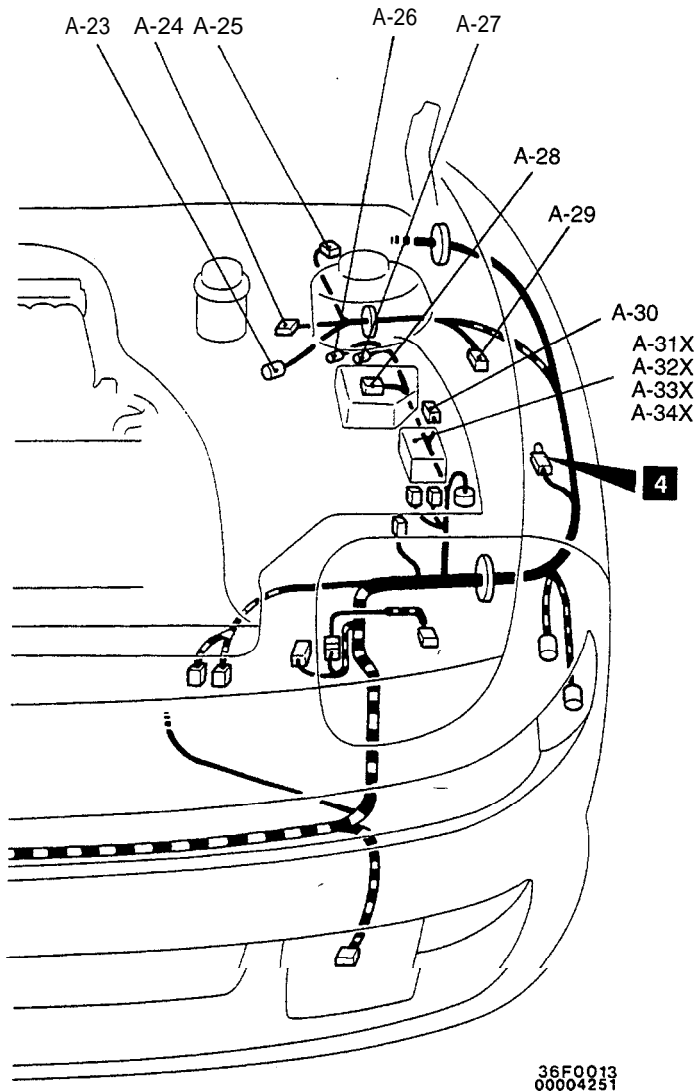

36F0013  
00004251

- |      |   |       |                                  |
|------|---|-------|----------------------------------|
| A-19 | Front washer motor                                  | A-27  | Theft-alarm horn                 |
| A-20 | Evaporative emission purge solenoid                 | A-26  | Auto-cruise vacuum pump          |
| A-21 | EGR solenoid (Vehicles for California)              | A-29  | ABS front speed sensor (LH)      |
| A-22 | EGR temperature sensor<br>(Vehicles for California) | A-30  | 4WS fluid level sensor <Turbo>   |
| A-23 | No connection <Turbo>                               | A-31X | Condenser fan motor relay (HI)   |
| A-24 | Brake fluid level sensor                            | A-32X | Radiator fan motor control relay |
| A-25 | ECS front shock absorber (LH)                       | A-33X | Magnetic clutch relay            |
| A-26 | Theft-alarm horn                                    | A-34X | Condenser fan motor relay (LO)   |

TSB Revision \_\_\_\_\_

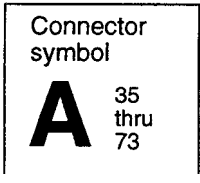

<Turbo>

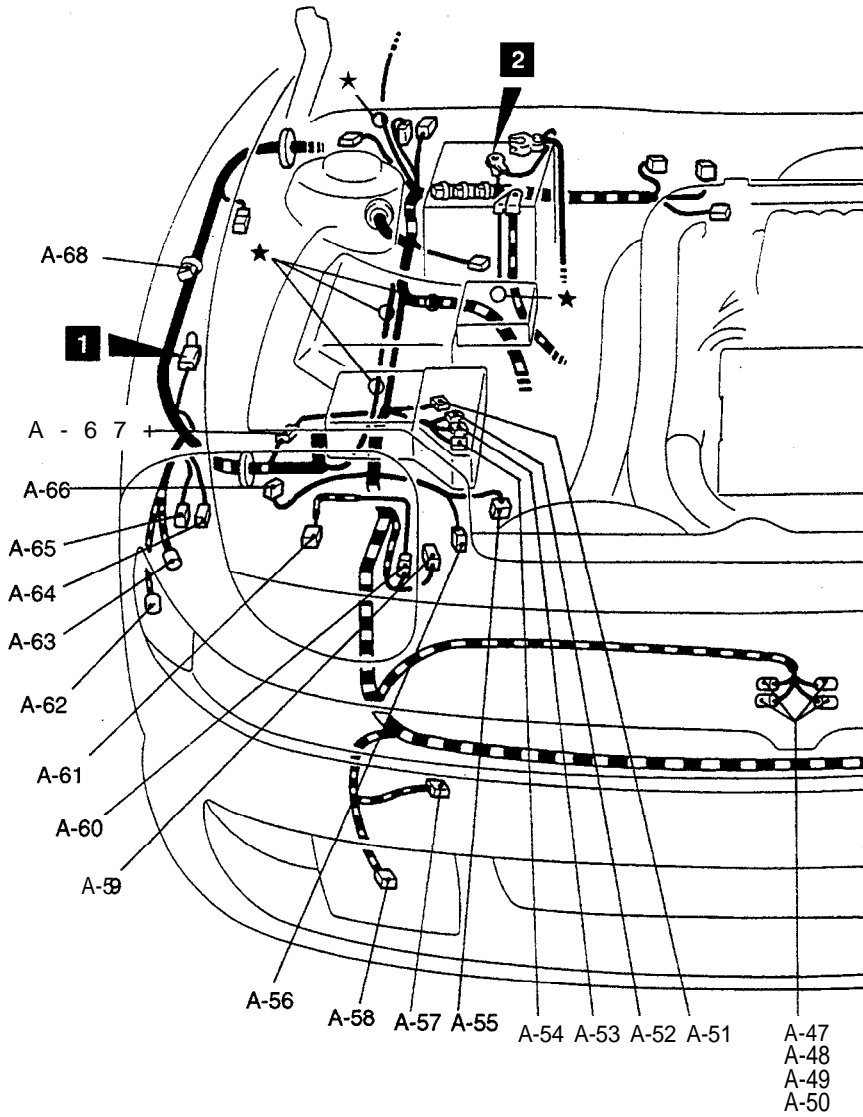
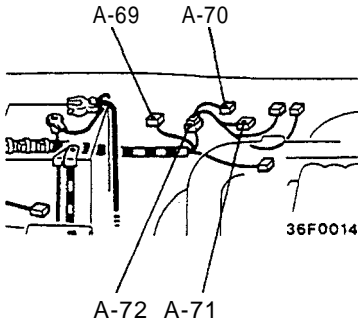

- A-35 Dual pressure switch
- A-36 Air conditioning relay box
- A-37 Air conditioning relay box
- A-38 **SRS** front impact sensor (LH)
- A-39 Front combination light (LH)
- A-40 inspection light switch
- A-41 Headlight (LH)
- A-42 Front wiring harness and headlight wiring harness (LH) combination
- A-43 Fog light (LH)
- A-44 Pop-up motor (LH)

- A-45 Condenser fan motor
- A-46 Condenser fan motor
- A-47 Horn
- A-48 Horn
- A-49 Horn
- A-50 Horn
- A-51 Fuel pump resistor <Turbo>
- A-52 A/T fluid temperature sensor
- A-53 Kickdown servo switch <A/T>
- A-54 Pulse generator <A/T>
- A-55 Radiator fan motor

TSB Revision

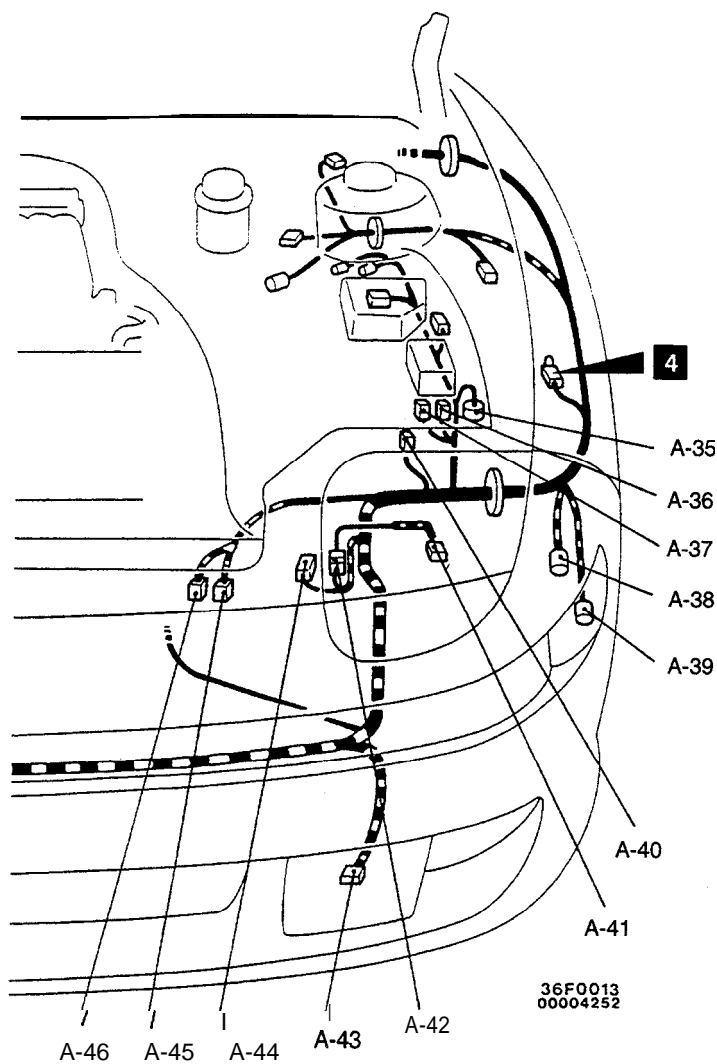

ENGINE HOOD

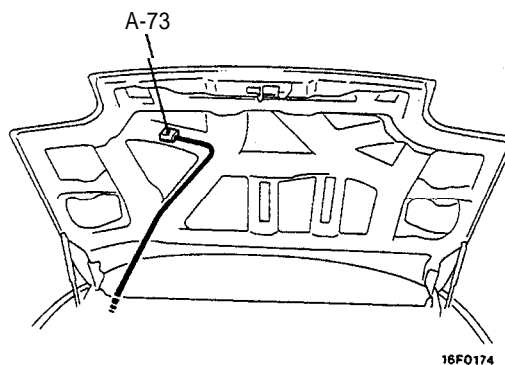

16F0174

36F0013  
00004252

- |      |  |      |   |
|------|--|------|---|
| A-56 | Engine coolant level sensor  | A-66 | Hood switch   |
| A-57 | Active aero front venturi skirt                                    | A-67 | Front wiring harness and control wiring harness combination   |
| A-58 | Fog light (RH)   | A-66 | Diode (for ABS circuit)                                       |
| A-59 | Pop-up motor (RH)  | A-69 | Resistor <Turbo>  |
| A-60 | Front wiring harness and headlight wiring harness (RH) combination | A-70 | Turbocharger waste gate solenoid <Turbo>                      |
| A-61 | Headlight (RH)   | A-71 | Fuel pressure solenoid <Turbo>                                |
| A-62 | Front combination light (RH)                                       | A-72 | Control wiring harness and solenoid valve harness combination |
| A-63 | SRS front impact sensor (RH)                                       | A-73 | Inspection light  |
| A-64 | ABS hydraulic unit   |      |   |
| A-65 | ABS hydraulic unit   |      |   |

TSB Revision



**ENGINE COMPARTMENT  
(FROM 1994 MODELS)**

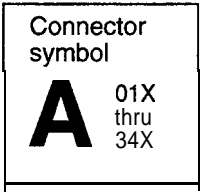

<Turbo>

A-20 A-21

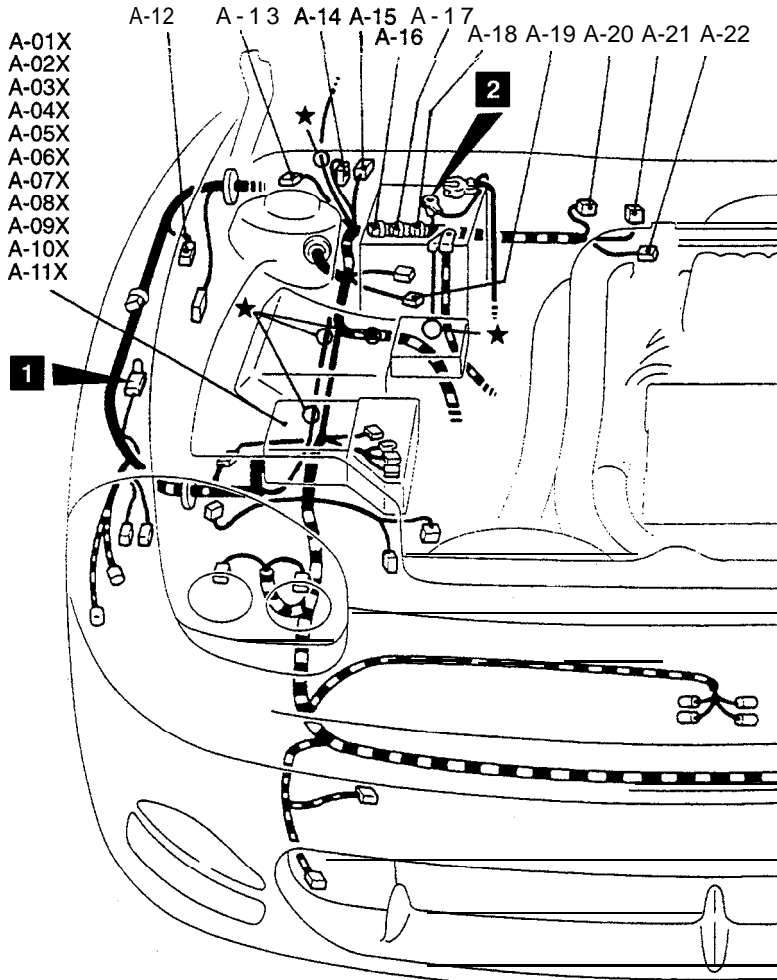
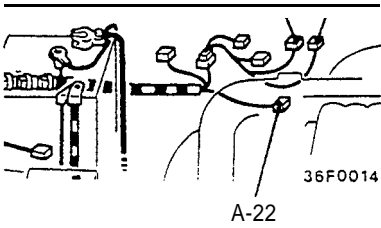

NOTE  
\*: Up to 1995 models

- A-01X Headlight relay
- A-02X ABS power relay
- A-03X Fog light relay
- A-04X Radiator fan motor relay (LO)
- A-05X Taillight relay
- A-06X Horn relay
- A-07X Radiator fan motor relay (HI)
- A-09X Starter relay
- A-10X Generator relay

- A-11X IOD or Storage connector
- A-12 ABS front speed sensor (RH)
- A-13 ECS front shock absorber (RH)\*
- A-14 Washer fluid level sensor
- A-15 Front wiper motor
- A-16 Engine speed detection connector
- A-17 Fuel pump check connector
- A-18 Ignition timing adjustment connector
- A-19 Front washer motor

**TSB Revision**

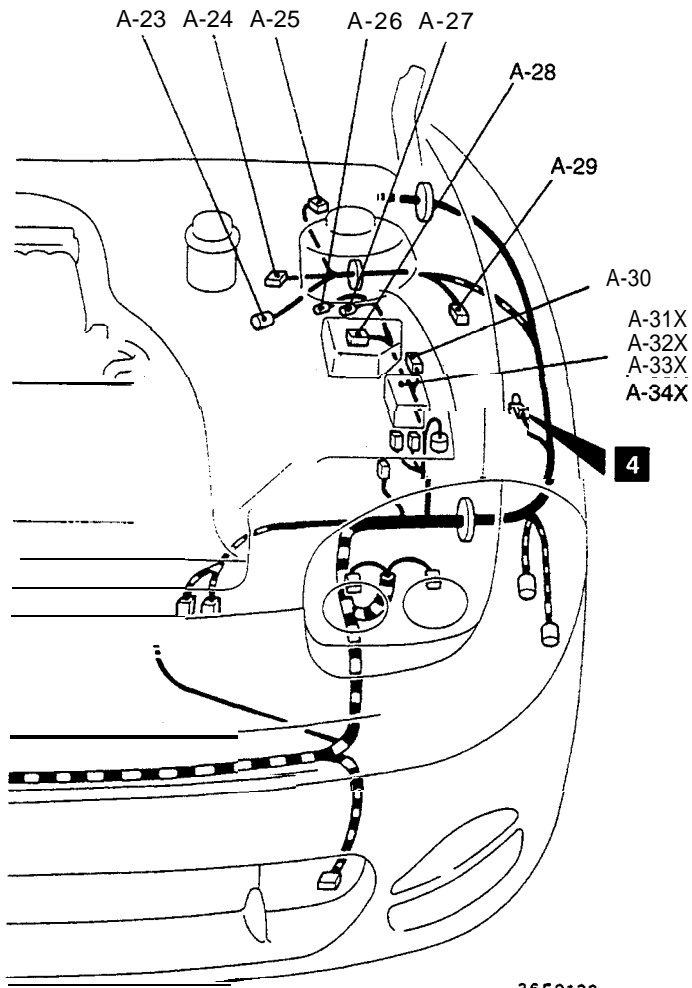

36F0122  
00004253

- |      |  |       |                                |
|------|--|-------|--------------------------------|
| A-20 | Evaporative emission purge solenoid  | A-26  | Theft-alarm horn               |
| A-21 | EGR solenoid   | A-27  | Theft-alarm horn               |
|      | <Turbo, Non Turbo (Up to 1995 models for California and from 1996 models)> | A-28  | Auto-cruise vacuum pump        |
| A-22 | EGR temperature sensor*  | A-29  | ABS front speed sensor (LH)    |
|      | <Turbo, Non Turbo (California)>  | A-30  | 4WS fluid level sensor <Turbo> |
| A-23 | No connection <Turbo>  | A-31X | Condenser fan motor relay (HI) |
| A-24 | Brake fluid level sensor   | A-33X | Magnetic clutch relay          |
| A-25 | ECS front shock absorber (LH)  | A-34X | Condenser fan motor relay (LO) |

TSB Revision

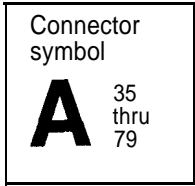

<Turbo> A 69 A-70

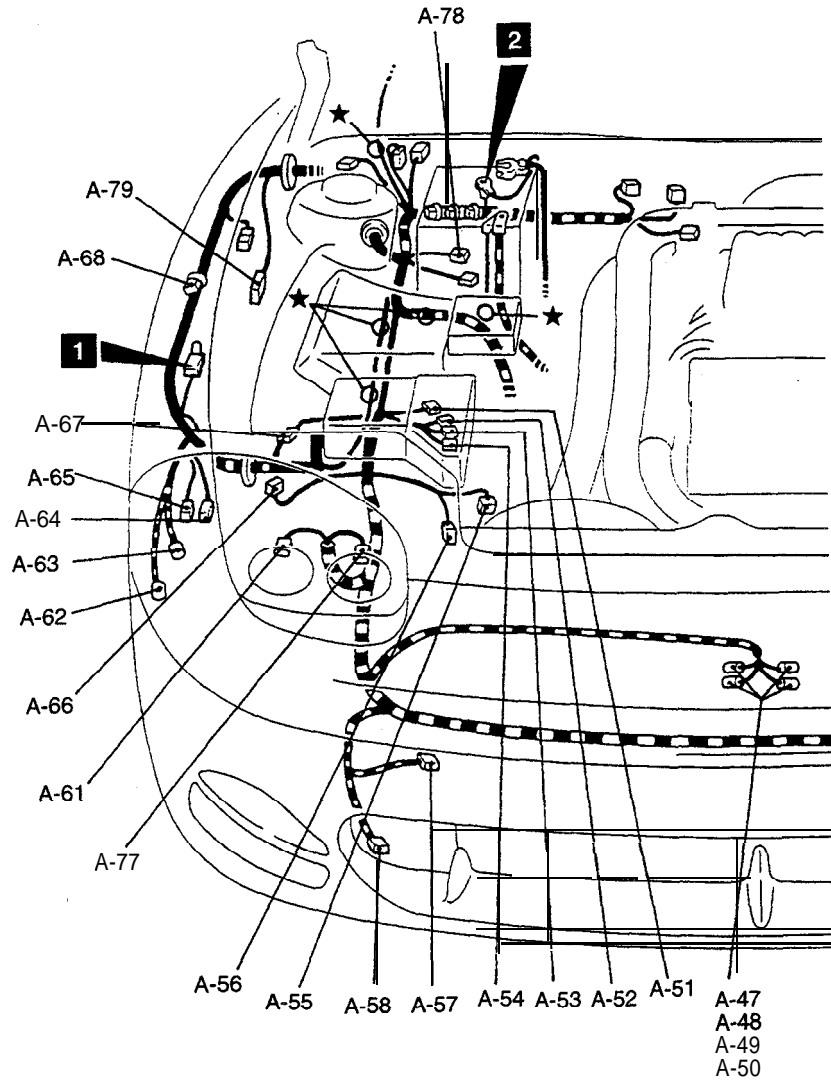
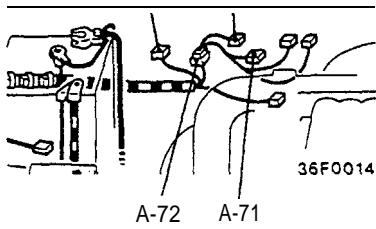

NOTE  
 \*1: Up to 1995 models  
 \*2: From 1996 models

- |      |                              |      |                                 |
|------|------------------------------|------|---------------------------------|
| A-35 | Dual pressure switch         | A 47 | Horn                            |
| A-36 | Air conditioning relay box   | A 48 | Horn                            |
| A-37 | Air conditioning relay box   | A 49 | Horn                            |
| A-38 | SRS front impact sensor (LH) | A 50 | Horn                            |
| A-39 | Front combination light (LH) | A-51 | Fuel pump resistor <Turbo>      |
| A-40 | Inspection light switch      | A-52 | A/T fluid temperature sensor    |
| A-41 | Headlight (LO, HI)           | A-53 | Kickdown servo switch <A/T>     |
| A-43 | Fog light (LH)               | A-54 | Pulse generator <A/T>           |
| A-44 | Pop-up motor (LH)            | A-55 | Radiator fan motor              |
| A-45 | Condenser fan motor          | A-56 | Engine coolant level sensor     |
| A-46 | Condenser fan motor          | A-57 | Active aero front venturi skirt |

TSB Revision

ENGINE HOOD

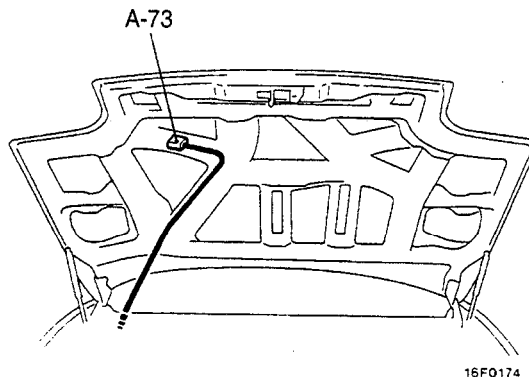
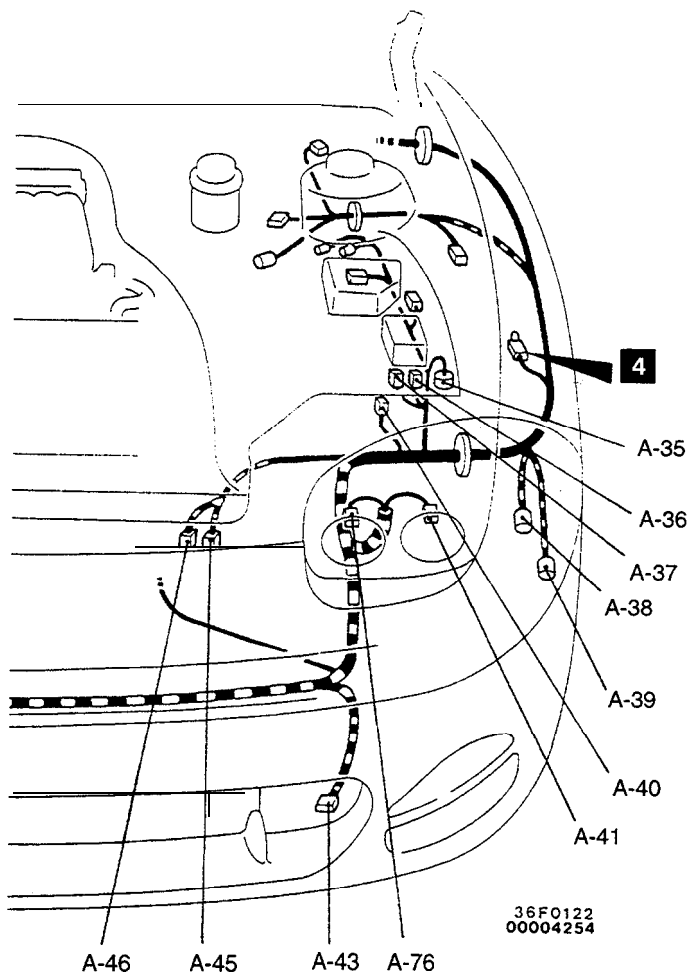

36F0122  
00004254

- |      |   |      |   |
|------|---|------|---|
| A-58 | Fog light (RH)  | A-69 | Resistor <Turbo>  |
| A-61 | Headlight (LO, RH)  | A-70 | Turbocharger waste gate solenoid <Turbo>                                    |
| A-62 | Front combination light (RH)                                | A-71 | Fuel pressure solenoid <Turbo>  |
| A-63 | SRS front impact sensor (RH)                                | A-72 | Control wiring harness and solenoid valve harness combination               |
| A-64 | ABS hydraulic unit  | A-73 | Inspection light  |
| A-65 | ABS hydraulic unit  | A-76 | Headlight (Hi, LH)  |
| A-66 | Hood switch   | A-77 | Headlight (Hi, RH)  |
| A-67 | Front wiring harness and control wiring harness combination | A-78 | No connection <Turbo>   |
| A-68 | Diode (for ABS circuit)*1                                   | A-79 | Motor antenna control unit <Convertible>*1 or motor antenna <Convertible>*2 |

TSB Revision

ENGINE AND TRANSAXLE <M/T>

Connector symbol  
**B**

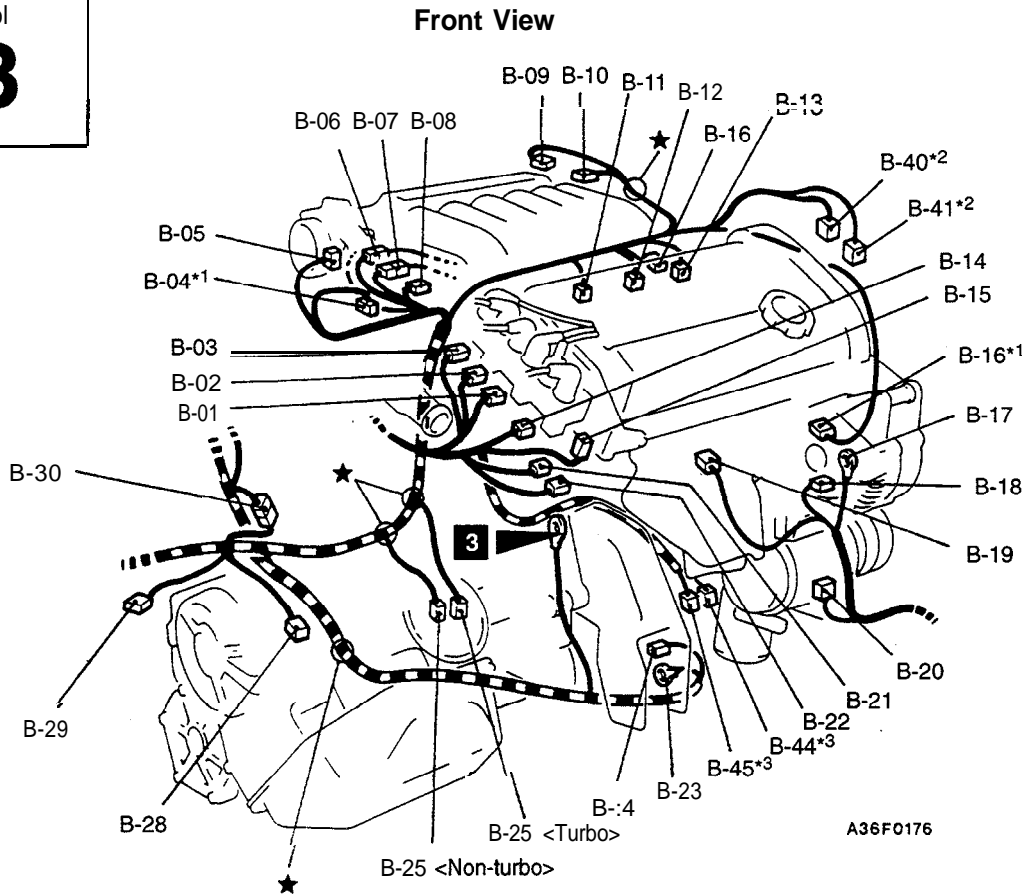

NOTE

- (1) \*1:1992 models
- (2) \*2: From 1993 models
- (3) \*3:1994, 1995 models for California and from 1996 models
- (4) \*4: From 1996 models

B-01	Engine coolant temperature gauge unit	B-10	Variable induction servo motor (with intake control valve position sensor) <Non-Turbo>
B-02	Engine coolant temperature sensor	B-11	Injector No. 5
B-03	Engine coolant temperature switch (for air conditioning circuit)	B-12	Injector No. 3
B-04	Crankshaft position sensor and camshaft position sensor*1	B-13	Injector No. 1
B-05	Throttle position sensor	B-14	Ignition coil
B-06	Control wiring harness and oil pressure wiring harness combination	B-15	Capacitor
B-07	Control wiring harness and injector wiring harness combination	B-16	Left bank heated oxygen sensor (front) <Turbo, Non Turbo – 1994, 1995 models for California and 1996 models>
B-08	Knock sensor	B-17	Generator
B-09	Variable induction servo motor (with intake control valve position sensor) <Non-Turbo>	B-18	Generator
		B-19	Right bank heated oxygen sensor (front)
		B-20	Magnetic clutch
		B-21	Power Transistor
		B-22	Power Transistor

TSB Revision

Rear View

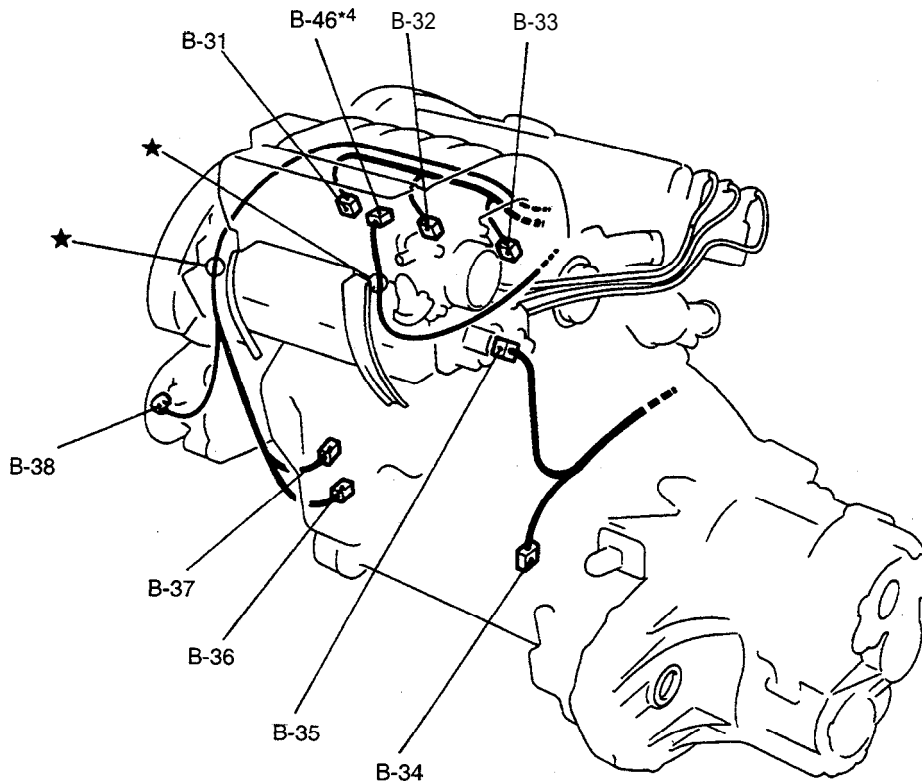

A36F0167

- |      |  |      |  |
|------|--|------|--|
| B-23 | Starter motor  | B-34 | Speed sensor <Turbo>                     |
| B-24 | Starter motor  | B-35 | Idle air control motor (stepper motor)   |
| B-25 | Back-up light switch   | B-36 | Oil pressure gauge unit                  |
| B-28 | Fuel pump relay <Turbo>  | B-37 | Oil pressure switch                      |
| B-29 | Volume air flow sensor (with intake air temperature sensor and atmospheric sensor) | B-38 | Power steering pressure switch           |
| B-30 | Control wiring harness and battery cable combination                               | B-40 | Camshaft position sensor*2               |
| B-31 | Injector No. 2   | B-41 | Crankshaft position sensor*2             |
| B-32 | Injector No. 4   | B-44 | Right bank heated oxygen sensor (rear)*3 |
| B-33 | Injector No. 6   | B-45 | Left bank heated oxygen sensor (rear)*3  |
|      |  | B-46 | Manifold differential pressure sensor*4  |

TSB Revision

ENGINE AND TRANSAXLE <A/T>

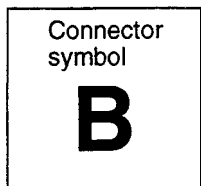

Front View

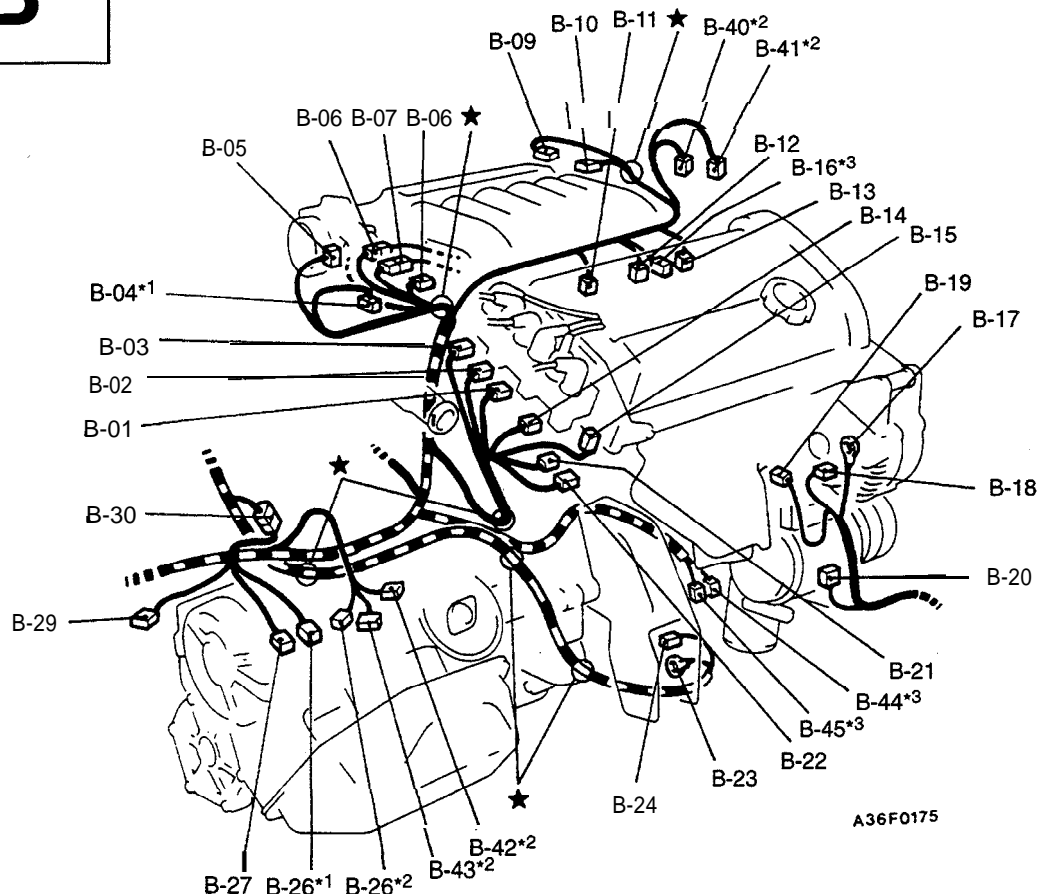

NOTE

- (1) \*1: 1992 models
- (2) \*2: From 1993 models
- (3) ● 1994, 1995 models for California and from 1996 models
- (4) \*4: From 1996 models

B-01	Engine coolant temperature gauge unit	B-10	Variable induction servo motor (with intake control valve position sensor)
B-02	Engine coolant temperature sensor	B-11	Injector No. 5
B-03	Air conditioning engine coolant temperature switch	B-12	Injector No. 3
B-04	Crankshaft position sensor and camshaft position sensor*1	B-13	Injector No. 1
B-05	Throttle position sensor	B-14	Ignition coil
B-06	Control wiring harness and oil pressure wiring harness combination	B-15	Capacitor
B-07	Control wiring harness and injector wiring harness combination	B-16	Left bank heated oxygen sensor (front)*3
B-08	Knock sensor	B-17	Generator
B-09	Variable induction servo motor (with intake control valve position sensor)	B-18	Generator
		B-19	Right bank heated oxygen sensor (front)
		B-20	Magnetic clutch
		B-21	Power transistor

Rear View

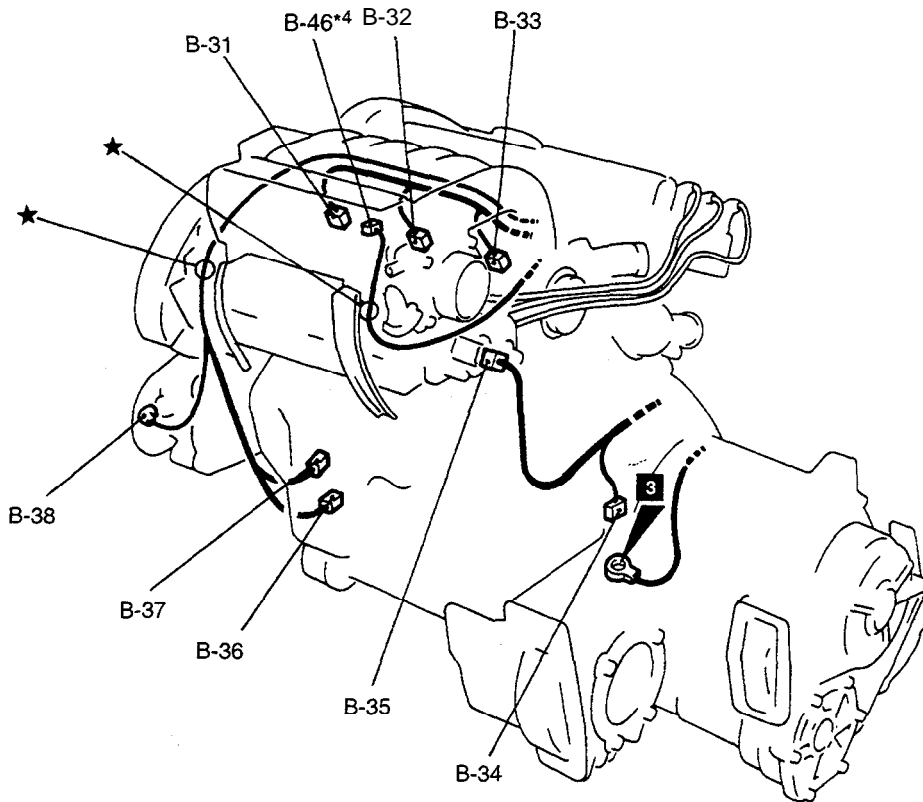

A36F0169

- |      |  |      |  |
|------|--|------|--|
| B-22 | Power transistor   | B-35 | Idle air control motor (stepper motor)   |
| B-23 | Starter motor  | B-36 | Oil pressure gauge unit                  |
| B-24 | Starter motor  | B-37 | Oil pressure switch                      |
| B-26 | Inhibitor switch   | B-38 | Power steering pressure switch           |
| B-27 | ELC-4 A/T control solenoid valve   | B-40 | Camshaft position sensor*2               |
| B-29 | Volume air flow sensor (with intake air temperature sensor and atmospheric sensor) | B-41 | Crankshaft position sensor*2             |
| B-30 | Control wiring harness and battery cable combination                               | B-42 | Kickdown servo switch*2                  |
| B-31 | Injector No. 2   | B-43 | AA fluid temperature sensor*2            |
| B-32 | Injector No. 4   | B-44 | Right bank heated oxygen sensor (rear)*3 |
| B-33 | Injector No. 6   | B-45 | Left bank heated oxygen sensor (rear)*3  |
| B-34 | Speed sensor   | B-46 | Manifold differential pressure sensor*4  |



## DASH PANEL

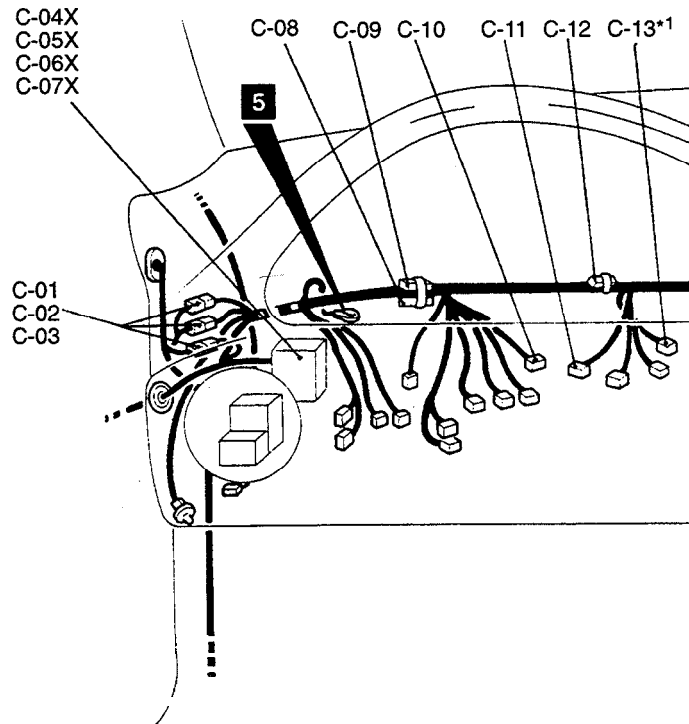
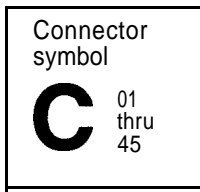

## NOTE

\*1: 1992 models

\*2: Up to 1995 models

C-01	Body wiring harness (LH) and front wiring harness combination	c-13	Accelerator pedal switch*1
C-02	Body wiring harness (LH) and front wiring harness combination	c-14	Control wiring harness and instrument panel wiring harness combination
c-o.3	Body wiring harness (LH) and front wiring harness combination	C-15	Body wiring harness (LH) and instrument panel wiring harness combination
C-04X	Door lock power relay 1	C-l 6	Air conditioning control panel
C-06X	Defogger relay	C-17	Air conditioning control panel
C-07X	Power window relay	C-l 8	Air conditioning switch
C-08	Diode (for seat belt warning circuit)	C-19	Blower switch
C-09	Diode (for seat belt warning circuit)	C-20	Heater control panel illumination light
C-10	Column switch	c-21	Blend air damper control motor
C-11	Column switch	c-22	Mode selection damper control motor
C-12	Diode (for theft-alarm circuit)	C-23	Power transistor (for full-auto air conditioning circuit)
		C-24	Blower resistor

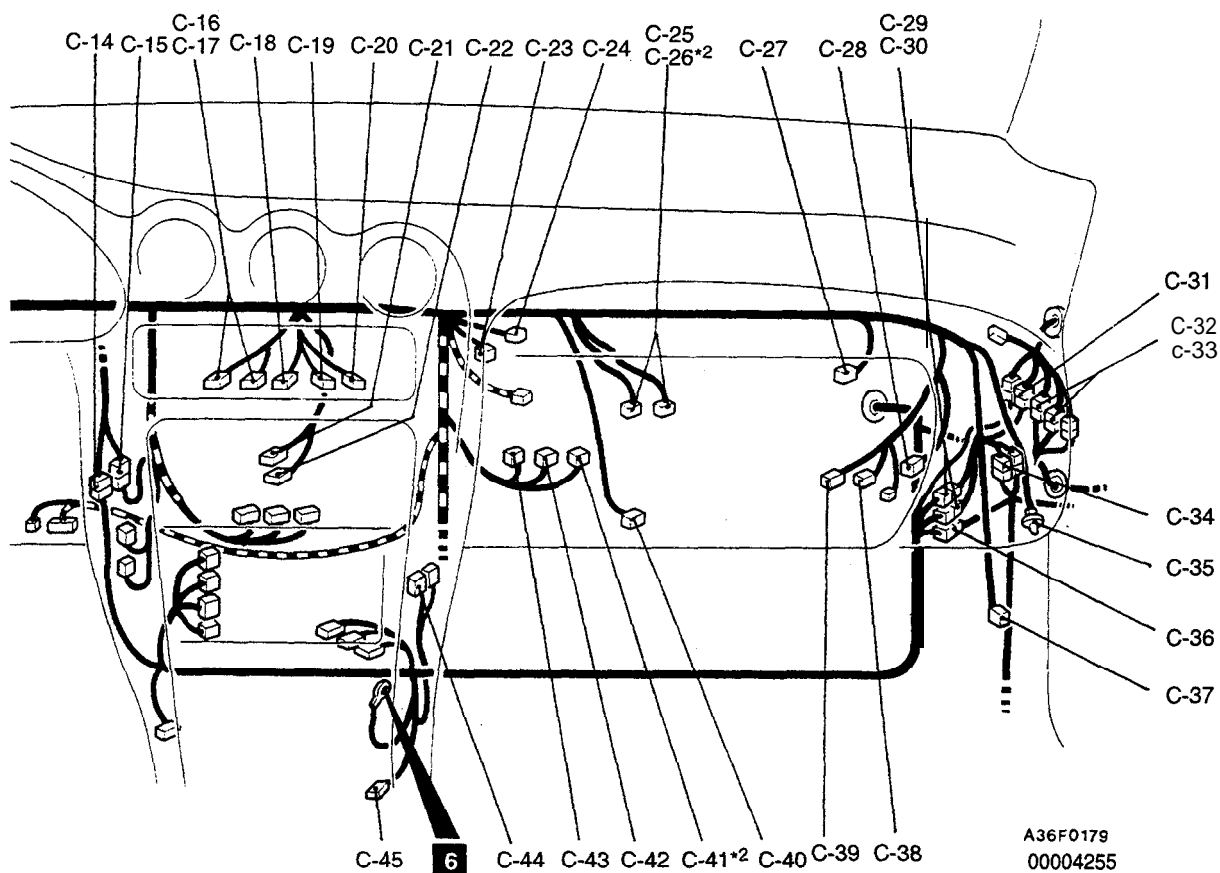

- |      |   |      |   |
|------|---|------|---|
| C-25 | Air conditioning control unit<br><Manual air conditioning>      | c-34 | Body wiring harness (LH) and body wiring harness (RH) combination |
| C-26 | Air conditioning control unit*2<br><Manual air conditioning>    | c-35 | Foot light (RH)   |
| C-27 | Air-inlet sensor <Full-auto air conditioning>                   | C-36 | Body wiring harness (RH) and control wiring harness combination   |
| C-28 | Air selection damper control motor                              | c-37 | Auto-cruise control unit  |
| c-29 | Body wiring harness (LH) and control wiring harness combination | C-38 | Blower motor  |
| C-30 | Body wiring harness (LH) and control wiring harness combination | c-39 | Blower motor relay (HI)   |
| c-31 | Body wiring harness (LH) and front wiring harness combination   | C-40 | Air conditioning compressor lock controller                       |
| C-32 | Body wiring harness (RH) and front wiring harness combination   | c-41 | Air-inlet sensor <Manual air conditioning>*2                      |
| c-33 | Body wiring harness (RH) and front wiring harness combination   | C-42 | Air-thermo sensor   |
|      |   | c-43 | Engine coolant temperature sensor                                 |
|      |   | C-44 | MFI relay   |
|      |   | c-45 | Over drive and power / economy switch                             |

TSB Revision

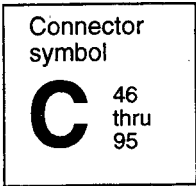

**JUNCTION BLOCK**  
 <Front side>

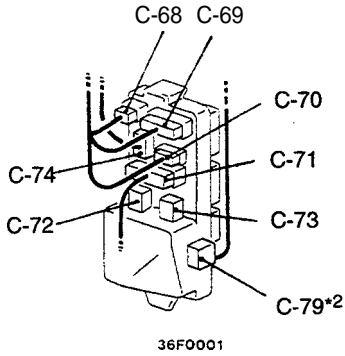

<Rear side>

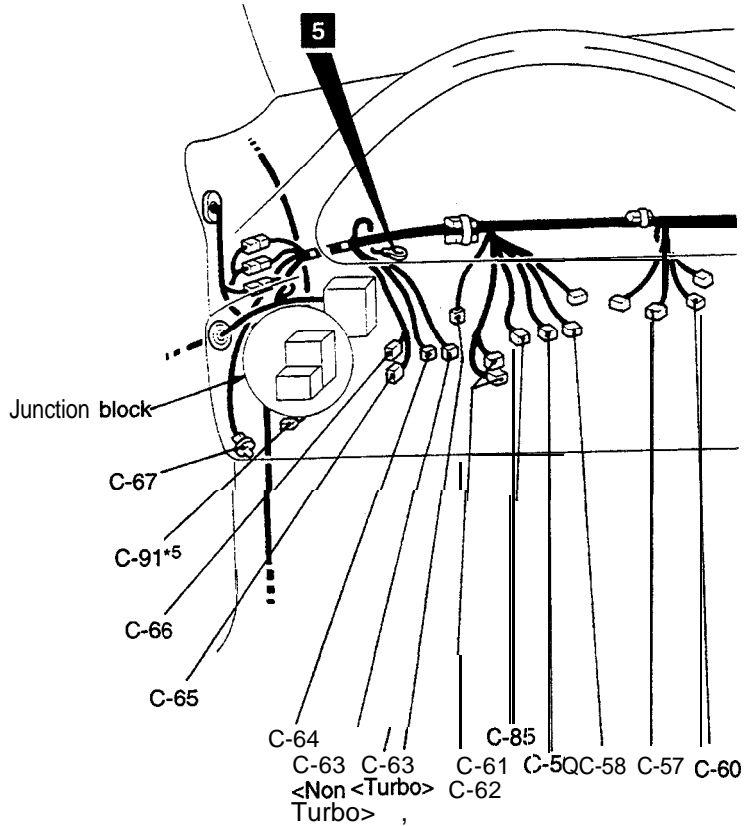
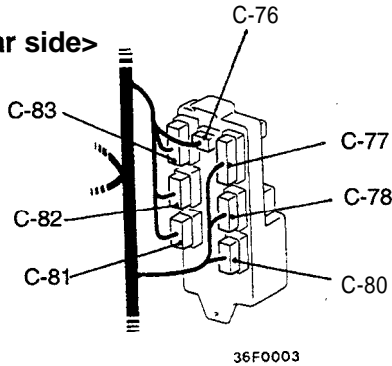

**NOTE**

- (1) \*1: 1992 Up to models 1993 models
- (2) \*3: From 1994 models
- (4) \*4: 1995 models
- (5) \*5: From 1996 models

- C-46 ELC-4 A/T control module
- c-47 ELC-4 A/T control module
- C-48 ELC-4 A/T control module\*1
- c-49 Air conditioning control unit  
 <Full-auto conditioning>
- C-50 Air conditioning control unit  
 <Full-auto conditioning>
- c-51 Air conditioning control unit  
 <Full-auto conditioning>
- C-52 Engine control module
- c-53 Engine control module
- C-54 Engine control module
- c-55 Left bank heated oxygen sensor (front)  
 <Non-Turbo except for California>
- C-56 Theft-alarm starter relay
- c-57 Clock spring
- C-58 Key reminder switch

- c-59 Ignition switch
- C-60 Steering wheel angle speed sensor
- C-61 Stop light switch
- C-62 Stop light switch
- C-63 Clutch pedal position switch (for auto-cruise control circuit)
- C-64 Clutch pedal position switch (for theft-alarm circuit)
- C-65 ETACS unit
- C-66 ETACS unit
- C-67 Foot light (LH)
- C-68 Front wiring harness and junction block combination
- C-69 Front wiring harness and junction block combination
- C-70 Front wiring harness and junction block combination

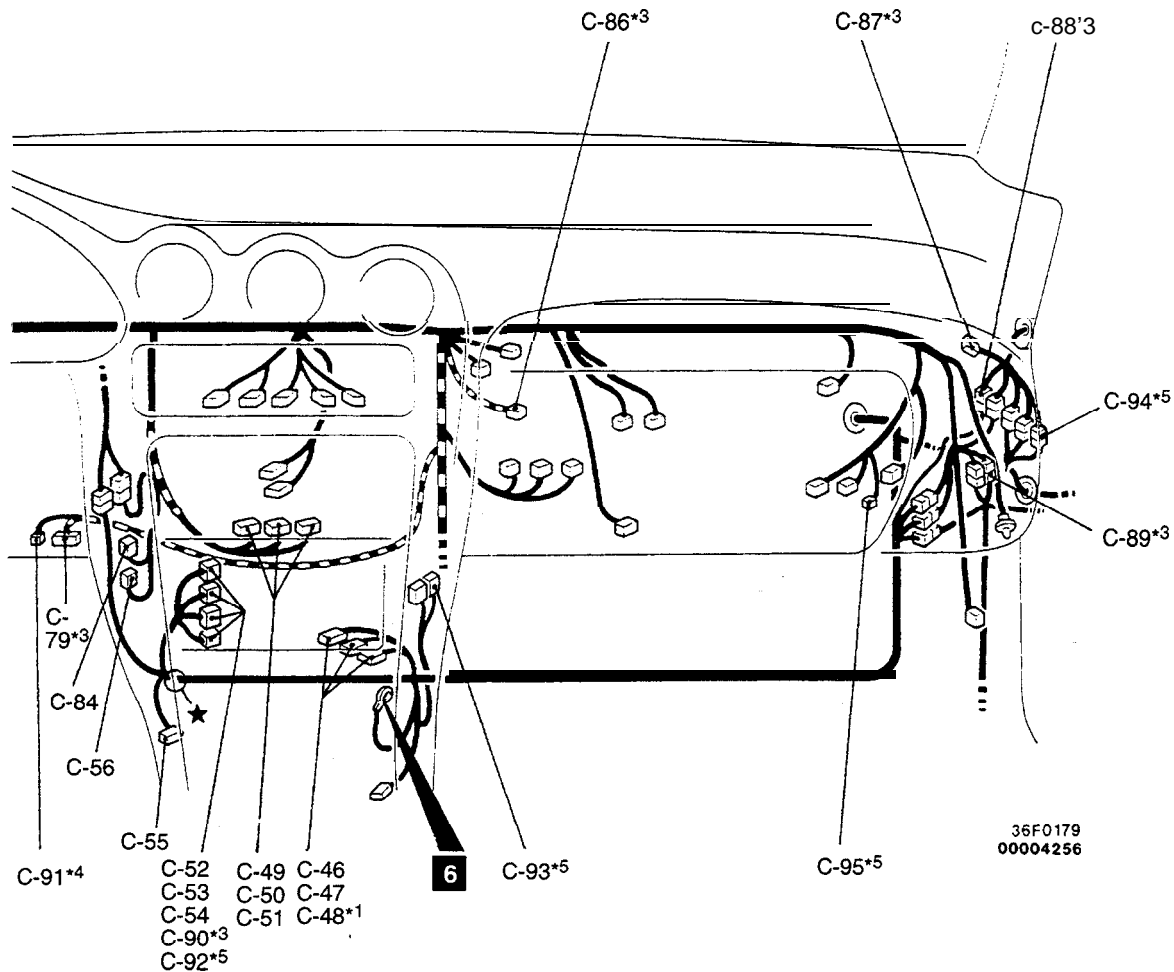

- |         |   |      |  |
|---------|---|------|--|
| c-71    | Adapter wiring harness and junction block combination   | C-83 | Body wiring harness (LH) and junction block combination                          |
| C-72    | Theft-alarm horn relay                                  | C-84 | Auto-cruise relay  |
| c-73    | Blower motor relay                                      | C-85 | Spare connector (Hand free microphone)   |
| c-74    | Roof wiring harness and junction block combination      | C-86 | Passenger's air bag module*3   |
| C-76    | Body wiring harness (LH) and junction block combination | C-87 | No connection <Turbo>  |
| c-77    | Body wiring harness (LH) and junction block combination | C-88 | Control wiring harness and front wiring harness combination*3                    |
| C-78    | Body wiring harness (LH) and junction block combination | C-89 | Body wiring harness (LH) and body wiring harness (RH) combination*3              |
| c-79    | Data link connector*3                                   | C-90 | Engine control module*3<br><Turbo, Non Turbo – Up to 1995 models for California> |
| C-80    | Body wiring harness (LH) and junction block combination | c-91 | Data link connector <Convertible>*4,*5   |
| C - 8 1 | Body wiring harness (LH) and junction block combination | c-92 | Engine control module*5  |
| C-82    | Body wiring harness (LH) and junction block combination | c-93 | MFI relay*5  |
|         |   | c-94 | Body wiring harness (RH) and front wiring harness combination*5                  |
|         |   | c-95 | Motor antenna control unit*5   |

INSTRUMENT PANEL AND FLOOR CONSOLE

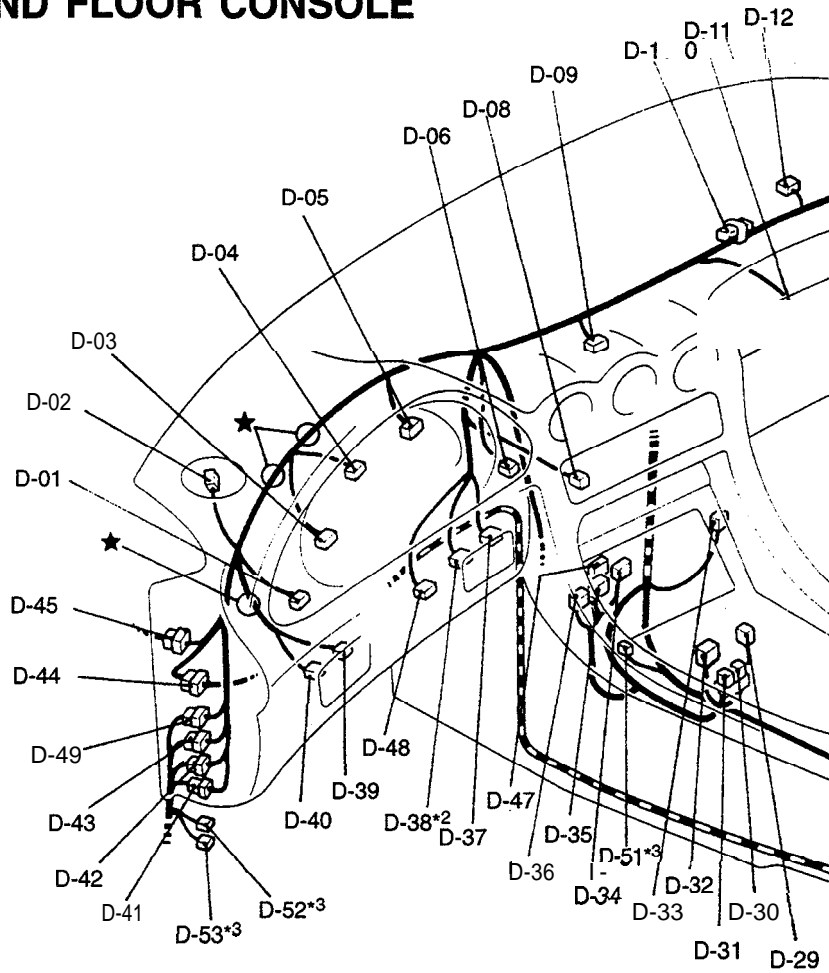
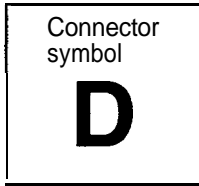

<On 1993 and later models>

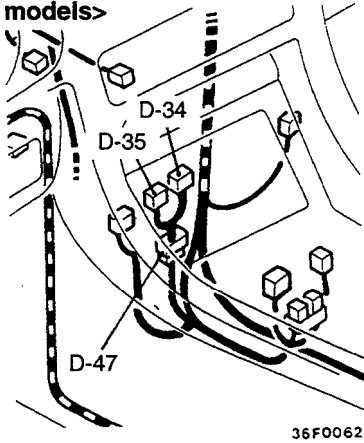

36F0062

NOTE

- (1) \*1: Up to 1993 models
- (2) \*2: Up to 1994 models
- (3) \*3: From 1996 models

D-01	Pop-up switch and fog light switch	D-1 6	Instrument panel wiring harness and body wiring harness (RH) combination
D-02	Front speaker (LH)	D-17	Ashtray illumination light
D-03	Combination meter	D-18	Cigarette lighter
D-04	Combination meter	D-19	Cigarette lighter
D-05	Combination meter	D-20	Cigarette lighter illumination light
D-06	Defogger switch and ECS switch	D-21	Power seat switch
D-08	Hazard switch	D-22	Body wiring harness (LH) and console wiring harness combination
D-09	Combination gauge	D-23	SRS diagnosis unit
D-1 0	Diode (for 4WS fluid level warning light circuit)	D-24	SRS diagnosis unit
D-11	Glove box illumination light	D-25	SRS diagnosis unit*1
D-12	Photo sensor	D-26	SRS diagnosis unit
D-13	Front speaker (RH)	D-27	ABS G sensor
D-14	Glove box illumination light switch	D-28	Parking brake switch
D-15	Instrument panel wiring harness and control wiring harness combination		

TSB Revision

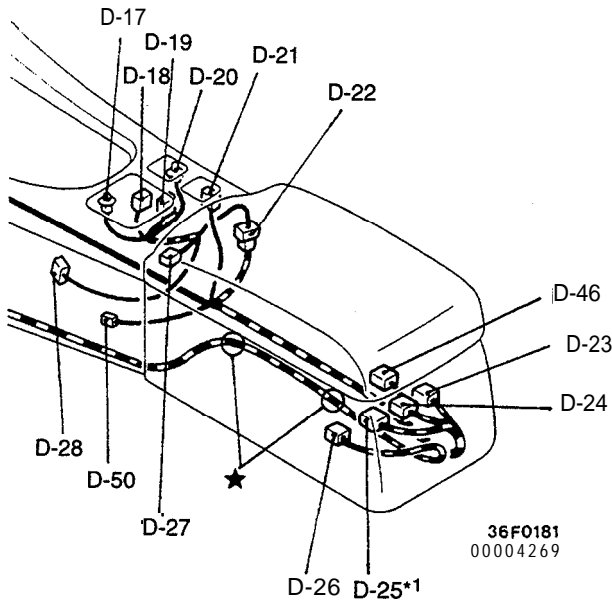
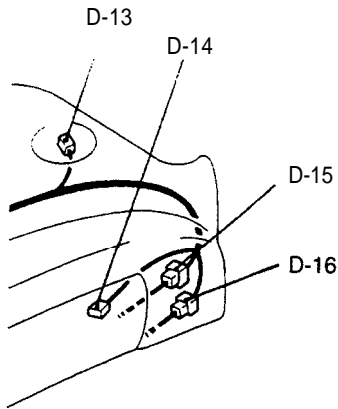

- |      |  |      |  |
|------|--|------|--|
| D-29 | Active aero switch <Hatchback>   | D-43 | Instrument panel wiring harness and body wiring harness (LH) combination               |
| D-30 | Accessory socket   | D-44 | Instrument panel wiring harness and adapter wiring harness combination                 |
| D-31 | Accessory socket   | D-45 | Instrument panel wiring harness and front wiring harness combination                   |
| D-32 | Auto-cruise main switch  | D-46 | Telephone cable  |
| D-33 | <b>Seatbelt</b> warning buzzer   | D-47 | Radio or body wiring harness and radio sub wiring harness combination                  |
| D-34 | Radio  | D-48 | Top switch <Convertible>   |
| D-35 | Radio  | D-49 | Instrument panel wiring harness and body wiring harness (LH) combination <Convertible> |
| D-36 | Radio  | D-50 | Parking switch <Convertible>   |
| D-37 | Rear wiper and washer switch <Hatchback>                                 | D-51 | <b>Chime</b> *3  |
| D-38 | Active exhaust <b>switch</b> *2  | D-52 | Body wiring harness (LH) and header wiring harness <b>combination</b> *3               |
| D-39 | Remote-control mirror switch   | D-53 | Body wiring harness (LH) and header wiring harness <b>combination</b> *3               |
| D-40 | Rheostat   |      |  |
| D-41 | Instrument panel wiring harness and body wiring harness (LH) combination |      |  |
| D-42 | Instrument panel wiring harness and body wiring harness (LH) combination |      |  |

INTERIOR

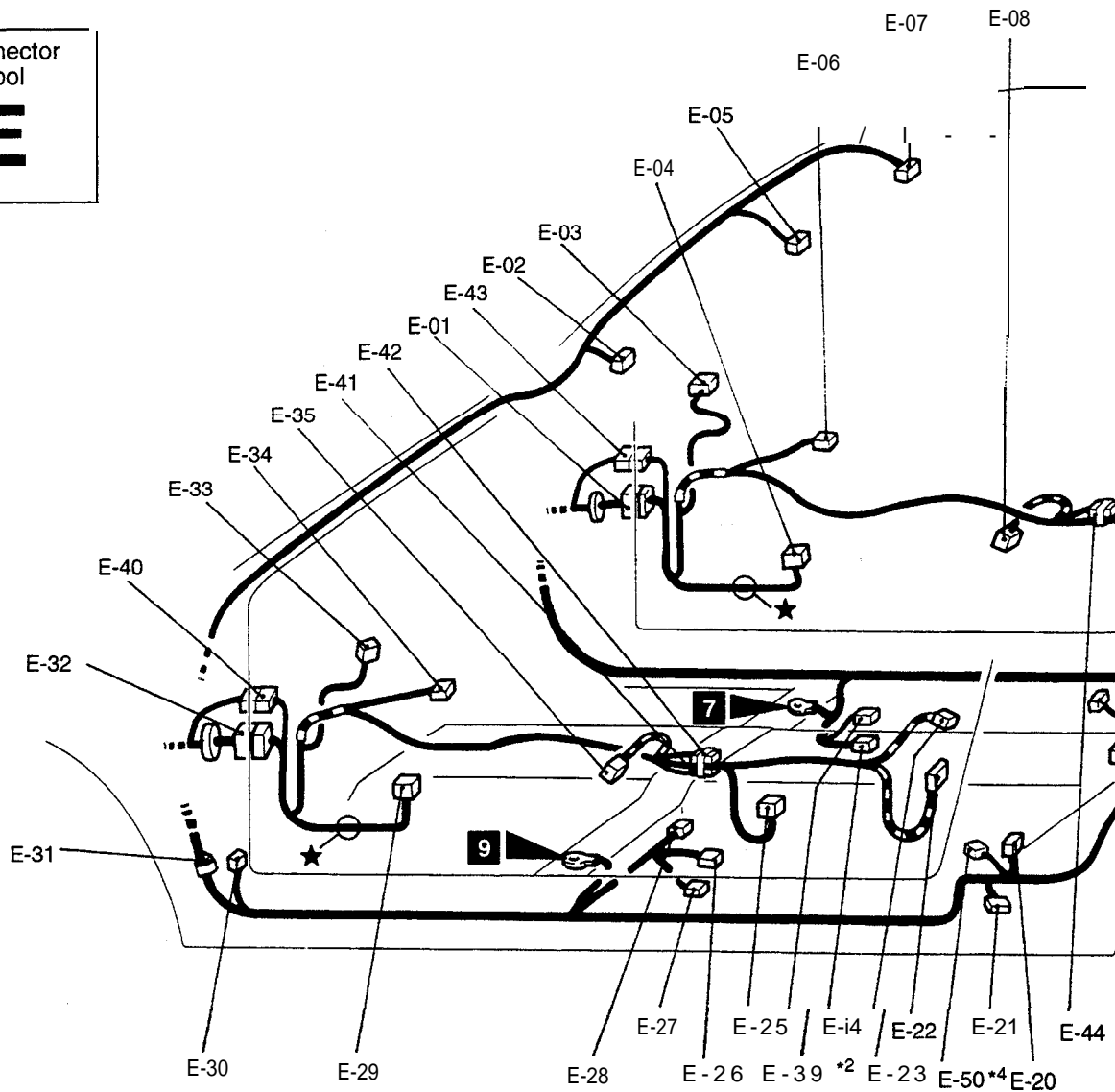
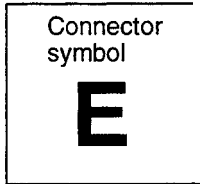

NOTE

- (1) \*1: From 1993 models
- (2) ● .\*: From 1994 models
- (3) \*3: Up to 1995 models
- (4) \*4: From 1996 models

E-01	Body wiring harness (RH) and door wiring harness (RH) combination
E-02	Vanity mirror illumination light (LH)
E-03	Door mirror (RH)
E-04	Door speaker (RH)
E-05	Dome light
E-06	Power window sub switch
E-07	Vanity mirror illumination light (RH)
E-08	Power window motor (RH)
E-09	Door light (RH)
E-10	Door key cylinder unlock switch (RH)
E-11	Door lock actuator (RH)
E-12	ABS control unit
E-13	ABS resistor <AWD>*3

E-14	Front seat belt solenoid (RH)
E-15	Door switch (RH)
E-16	ABS rear speed sensor (RH)
E-17	Light automatic shut-OFF unit
E-18	Rear intermittent wiper relay
E-19	ABS rear speed sensor (LH)
E-20	Front seat belt solenoid (LH)
E-21	Door switch (LH)
E-22	Door lock actuator (LH)
E-23	Door key cylinder unlock switch (LH)
E-24	Front seat belt switch (RH)
E-25	Door light (LH)
E-26	Front seat belt switch (LH)
E-27	Power seat assembly

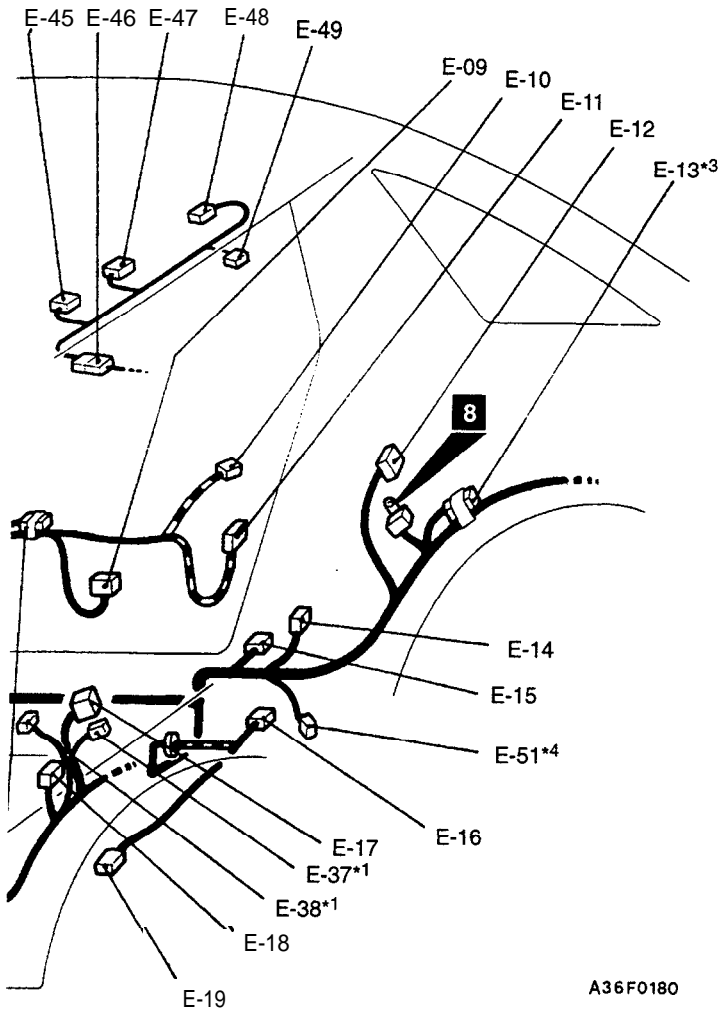

A36F0180

- |      |   |      |   |
|------|---|------|---|
| E-28 | ECS G sensor  | E-41 | Jumper connector A (LH) <Convertible>   |
| E-29 | Door speaker  | E-42 | Jumper connector B <Convertible>  |
| E-30 | Turn signal and hazard flasher unit   | E-43 | Body wiring harness (RH) and door wiring harness (RH) combination <Convertible>   |
| E-31 | Diode (for MFI circuit)   | E-44 | Jumper connector A (RH) <Convertible>   |
| E-32 | Body wiring harness (LH) and door wiring harness (LH) combination               | E-45 | Sunroof control unit  |
| E-33 | Door mirror (LH)  | E-46 | <b>Liftgate</b> wiring harness and sunroof wiring harness combination <Hatchback> |
| E-34 | Power window main switch  | E-47 | Sunroof switch  |
| E-35 | Power window motor (LH)   | E-48 | Sunroof motor   |
| E-37 | <b>Keyless control Unit</b> *1  | E-49 | Interior temperature sensor <Vehicles with sunroof>                               |
| E-38 | Door lock power relay 2*1 (for keyless control system)                          | E-50 | Rear courtesy light (LH) <Convertible>*4  |
| E-39 | <b>Amplifier</b> *2   | E-51 | Rear courtesy light (RH) <Convertible>*4  |
| E-40 | Body wiring harness (LH) and door wiring harness (LH) combination <Convertible> |      |   |

TSB Revision



LUGGAGE COMPARTMENT

<HATCHBACK>

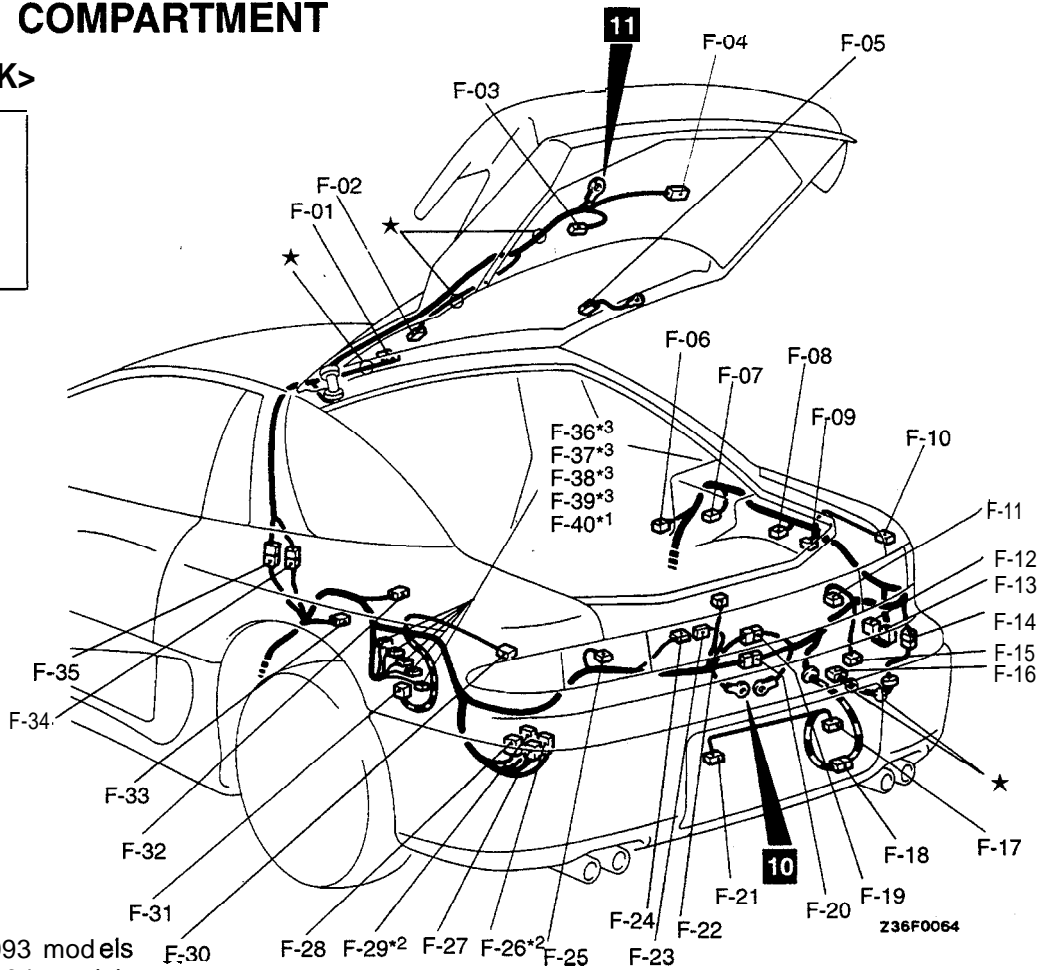
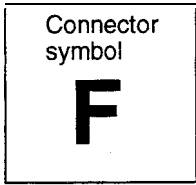

NOTE

- (1) ● : From 1993 models
- (2) \*2: Up to 1994 models
- (3) \*3-: Up to 1993 models

F-01	Interior temperature sensor	F-21	License plate light (LH)
F-02	Defogger (+)	F-22	Luggage compartment light switch
F-03	Rear wiper motor	F-23	Liftgate cylinder lock switch
F-04	High-mounted stop light or active aero rear spoiler	F-24	Liftgate switch
E-05	Defogger (-)	F-25	Back-up light (LH)
F-06	Rear speaker (RH)	F-26	Active exhaust control unit*2
F-07	ECS rear shock absorber (RH)	F-27	Active aero control unit
F-08	Luggage compartment light	F-28	Active aero control unit
F-09	ABS resistor <FWD>	f-29	Active exhaust actuator assembly*2
F-10	Rear combination light (RH)	F-30	Rear combination light (LH)
F-11	Back-up light (RH)	F-31	Motor antenna control unit
F-12	ECS control unit	F-32	ECS rear shock absorber (LH)
F-13	ECS control unit	F-33	Rear speaker (LH)
F-14	Body wiring harness (RH) and fuel tank wiring harness combination	F-34	Body wiring harness (LH) and liftgate wiring harness combination
F-15	Rear washer motor	F-35	Body wiring harness (LH) and liftgate wiring harness combination
F-16	Fuel tank	F-36	Telephone cable*3
F-17	License plate light (RH)	F-37	Spare connector (Wireless telephone unit)*3
F-18	Body wiring harness (RH) and rear bumper wiring harness combination	F-38	Spare connector (Hand free controller)*3
F-19	Body wiring harness (LH) and body wiring harness (RH) combination	F-39	Jumper connector (or Hand free controller)*3
F-20	Body wiring harness (LH) and body wiring harness (RH) combination	F-40	CD changer*1

<CONVERTIBLE>

1995 models

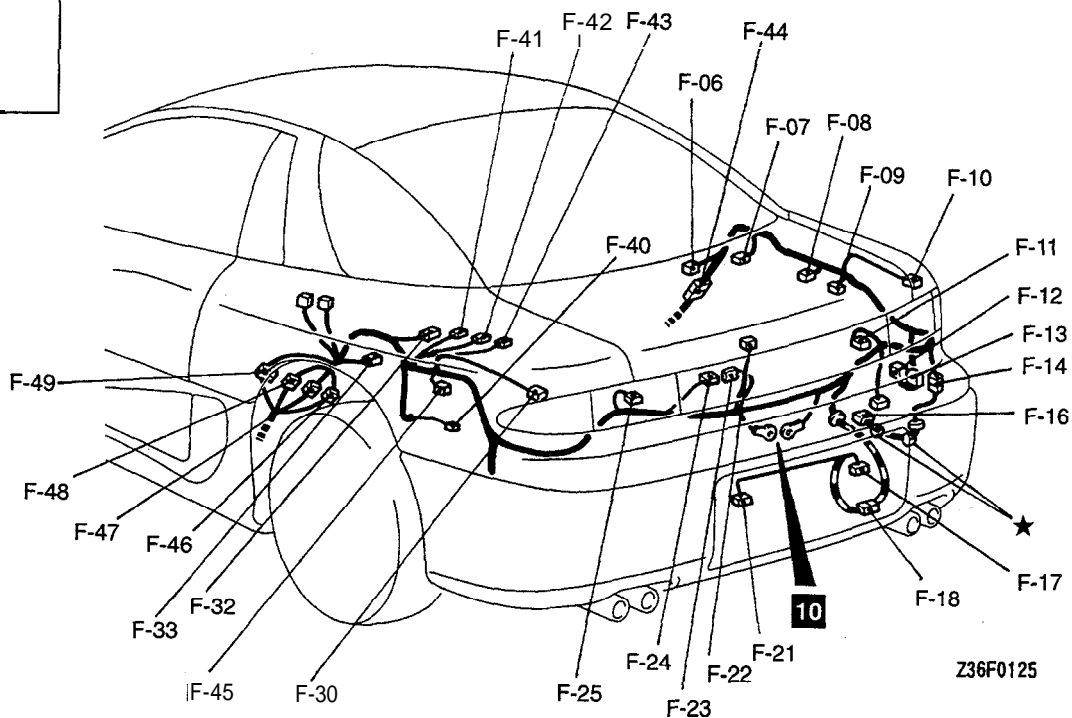
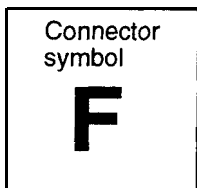

- |      |   |      |  |
|------|---|------|--|
| F-05 | Defogger (-)  | F-25 | Back-up light (LH)   |
| F-06 | Rear speaker (RH)   | F-30 | Rear combination light (LH)                                  |
| F-07 | ECS rear shock absorber (RH)  | F-32 | ECS rear shock absorber (LH)                                 |
| F-08 | Luggage compartment light   | F-33 | Rear speaker (LH)  |
| F-09 | <b>ABS</b> resistor   | F-40 | CD changer   |
| F-10 | Rear combination light (RH)   | F-41 | Top stack harness  |
| F-11 | Back-up light (RH)  | F-42 | Top stack harness  |
| F-12 | ECS control unit  | F-43 | Top stack harness  |
| F-13 | ECS control unit  | F-44 | Body wiring harness (RH) and rear wiring harness combination |
| F-14 | Rear wiring harness (RH) and fuel tank wiring harness combination   | F-45 | ABS resistor   |
| F-16 | Fuel tank   | F-46 | Body wiring harness (LH) and rear wiring harness combination |
| F-17 | License plate light (RH)  | F-47 | Body wiring harness (LH) and rear wiring harness combination |
| F-18 | Rear wiring harness (RH) and rear bumper wiring harness combination | F-48 | Body wiring harness (LH) and rear wiring harness combination |
| F-21 | License plate light (LH)  | F-49 | Body wiring harness (LH) and rear wiring harness combination |
| F-22 | Luggage compartment light switch                                    |      |  |
| F-23 | Liftgate cylinder lock switch                                       |      |  |
| F-24 | Liftgate switch   |      |  |

TSB Revision

## &lt;CONVERTIBLE&gt;

From 1996 models

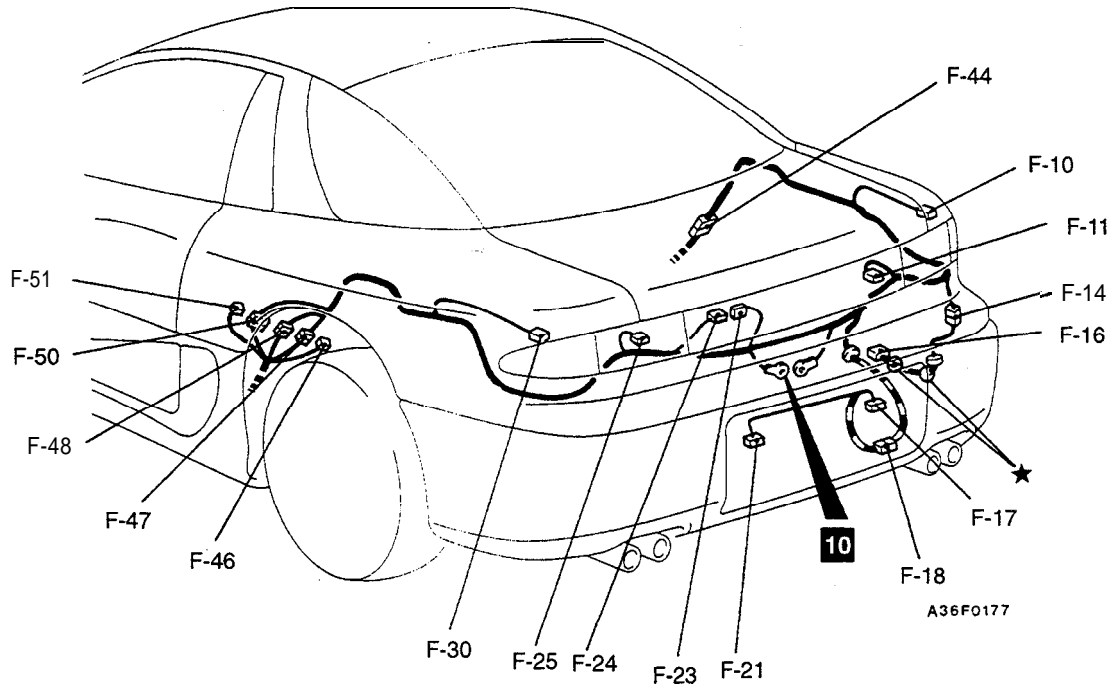
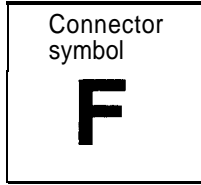

F-10	Rear combination light (RH)	F-25	Back-up light (LH)
F-11	Back-up light (RH)	F-30	Rear combination light (LH)
F-14	Rear wiring harness (RH) and fuel tank wiring harness combination	F-44	Body wiring harness (RH) and rear wiring harness combination
F-16	Fuel tank	F-46	No connection
F-17	License plate light (RH)	F-47	Body wiring harness (LH) and rear wiring harness combination
F-18	Rear wiring harness (RH) and rear bumper wiring harness combination	F-48	Body wiring harness (LH) and rear wiring harness combination
F-21	License plate light (LH)	F-50	No connection
F-23	Liftgate cylinder lock switch	F-51	No connection
F-24	Liftgate switch		

TSB Revision

# CIRCUIT DIAGRAMS

## CONTENTS

Active Aero Circuit .....	428	Heater Circuit .....	239
Active Exhaust System Circuit .....	370	Horn .....	54-116
Anti-lock Braking System (ABS) Circuit .....	322	How to Read Circuit Diagrams .....	62
Auto-cruise Control Circuit .....	380	Ignition System .....	16-32
Back-up Light .....	54-85	Manual Air Conditioning Circuit .....	242
Buzzer Circuit .....	208	Meter and Gauges Circuit .....	54-12
Car Telephone Circuit .....	435	MFI Circuit .....	84
Central Door Locking Circuit .....	222	Power Distribution Circuit .....	68
Charging System .....	16-3	Power Seat Circuit .....	416
Cigarette Lighter Circuit .....	54-120	Power Window Circuit .....	212
Cooling Circuit .....	176	Radio and Tape Player .....	54-124
Defogger Circuit .....	54-193	Rear. Wiper and Washer Circuit .....	318
Dome Light, Foot Light and Ignition Key Cylinder Illumination Light .....	54-72	Remote Controlled Mirror Circuit .....	320
Door Light and Luggage Compartment Light .....	54-81	Starting System .....	16-20
ELC-4 A/T Circuit .....	186	Stop Light .....	54-98
Electronic Control Suspension (ECS) Circuit ..	352	Sunroof Circuit .....	442
Fog Light Circuit .....	54-58	Supplemental Restraint System (SRS) Circuit .....	374
Full Auto Air Conditioning' Circuit .....	272	Taillight, Parking/Side Marker Light and License Plate Light Circuit .....	54-64
Glove Box Light, Vanity Mirror Light and Inspection Light Circuit .....	54-84	Tension-reducer Type Seat Belt Circuit .....	423
Headlight .....	54-40	Theft-alarm System .....	54-206
		Top Stack Circuit .....	438
		Turn-signal Light and Hazard Light .....	54-90
		Windshield Wiper and Washer Circuit .....	316

# HOW TO READ CIRCUIT DIAGRAMS

The circuit of each system from the fuse (or fusible link) to ground is shown. The power supply is shown at the top and the ground at the bottom to facilitate understanding of how the current flows.

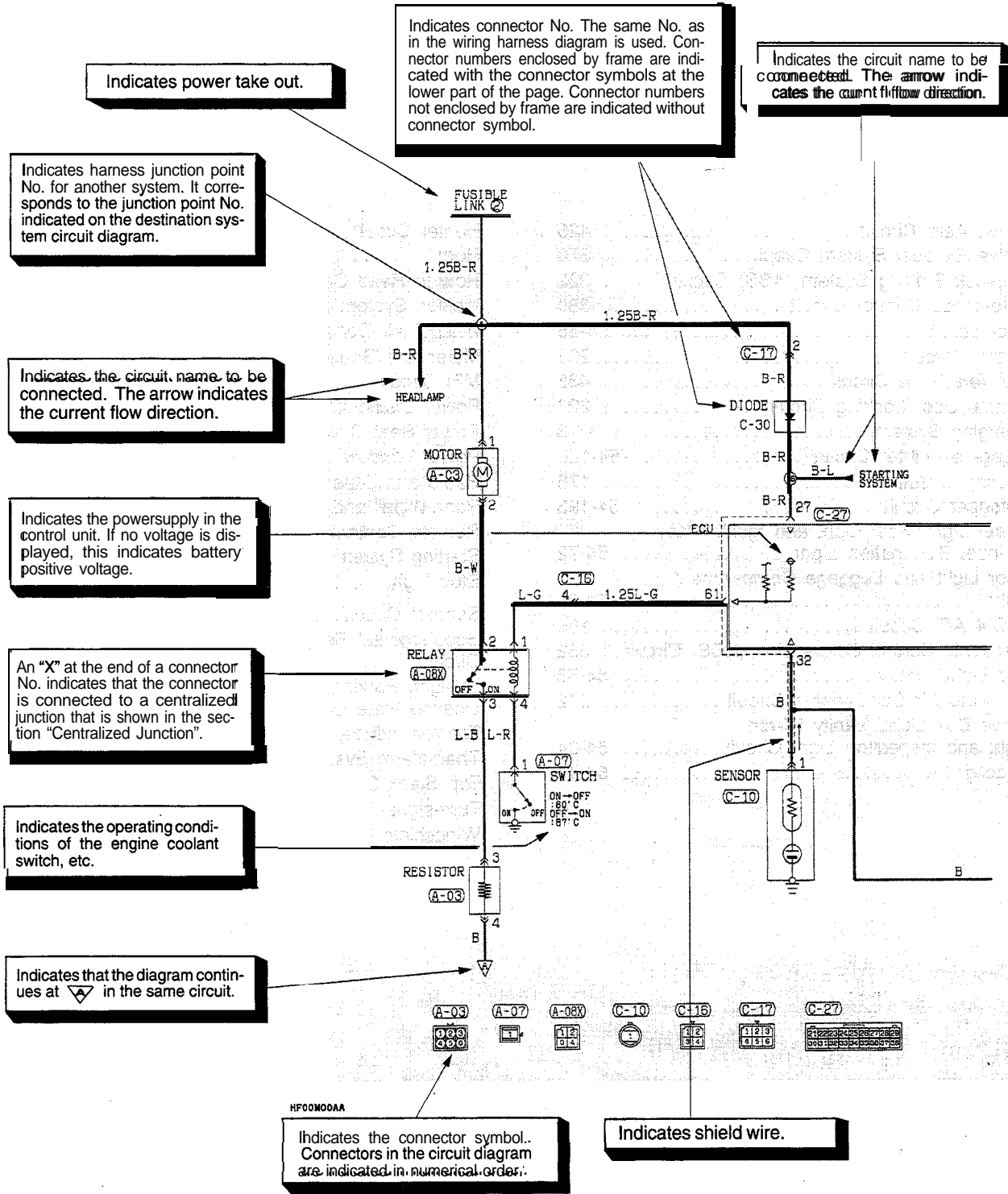

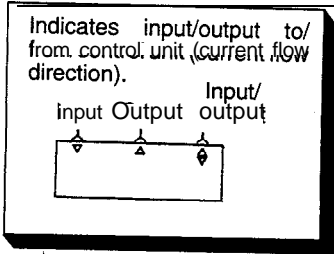

A broken line indicates that these connectors are the same intermediate connectors.

Indicates that the diagram comes from in the same circuit.

Indicates terminal No.

In case two or more connectors are connected to the same device, markings indicating the same connector are connected by a broken line.

Indicates current flow downward or upward as controlled by the control unit.

Indicates harness junction where wire diameter or color changes.

Indicates intersections at which the lead wires are not connected.

Indicates intersections at which the lead wires are connected.

Indicates vehicle body ground point. (Same No. as that of ground point in GROUNDING LOCATION).

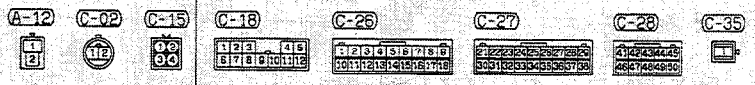
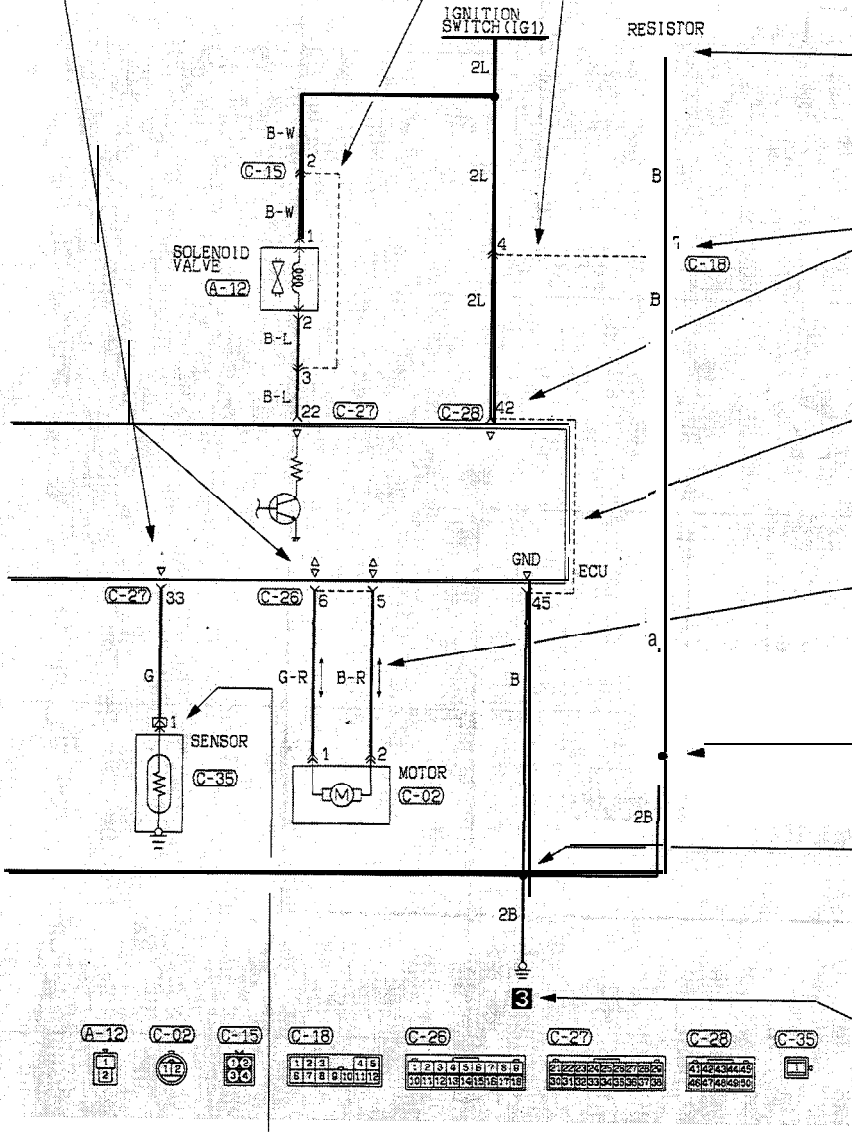

Indicates that the terminal is a spare one if the device (sensor in this case) is not provided.





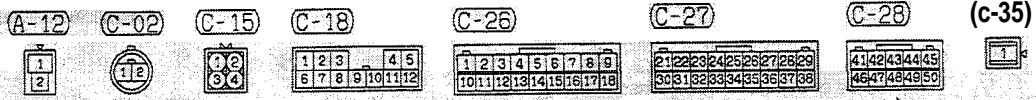
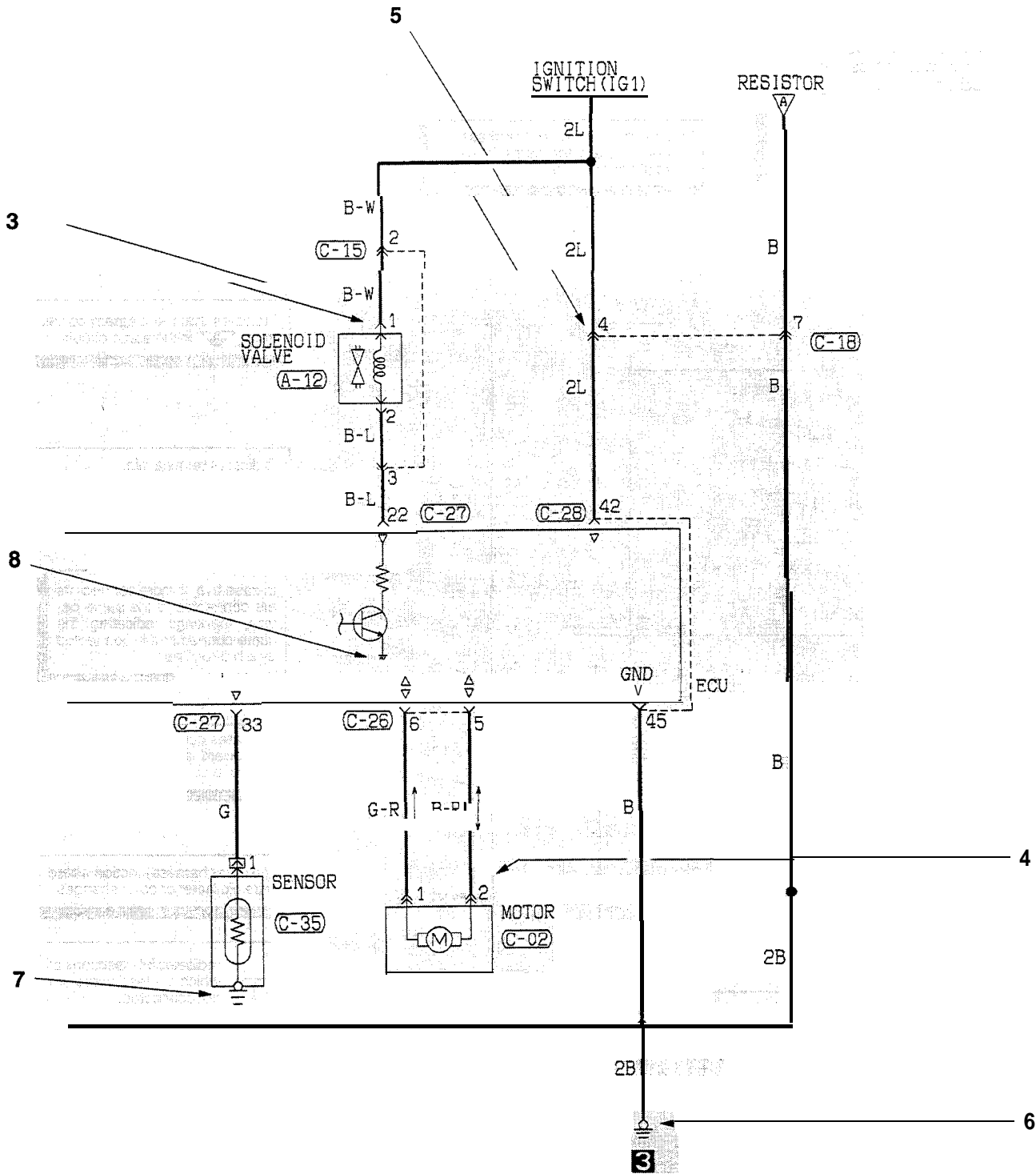

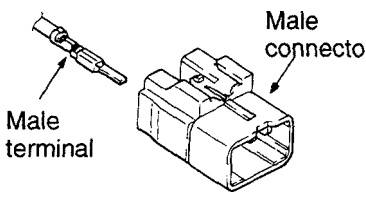

HF00M00AB

CONNECTOR / GROUNDING INDICATIONS

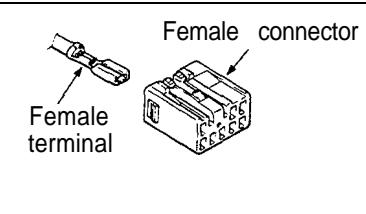



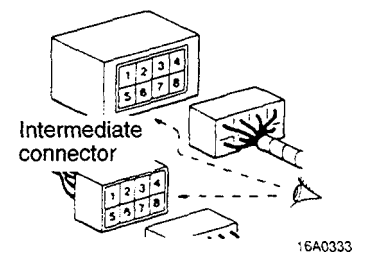
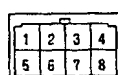
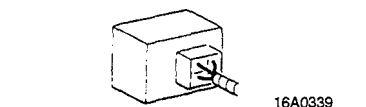
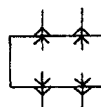
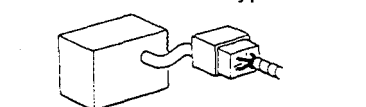
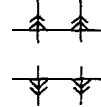
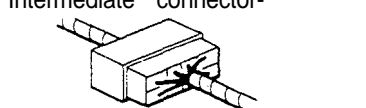

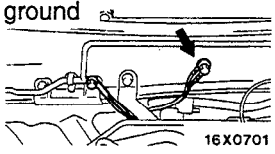

HF00M00AB

TSB Revision

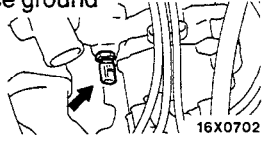
Item	No.	Connector / Grounding	Symbol	Contents
Connector and terminal marking	1	 <p>Male terminal</p> <p>Male connector</p> <p>A16R0001</p>	<p>Male terminal</p> 	<p>For the terminal symbols, the connected terminal is indicated as the male terminal, and the receptacle terminal is indicated as the female terminal as shown in the illustration.</p> <p>The connector in which the male terminal is assembled is indicated as the male connector and the connector in which the female is assembled is indicated as the female connector. The connector symbols shown the male connector with a double outer contour line and the female connector with a single outer contour line.</p>
		 <p>Female terminal</p> <p>Female connector</p> <p>A16R0002</p>	<p>Female terminal</p> 	
		<p>Male connector</p> 		
		<p>Female connector</p> 		
Connector symbol marking	2	<p>Device</p>  <p>Intermediate connector</p> <p>16A0333</p>		<p>The symbol indicates the connector as viewed from the illustrated direction. At the connection with a device, the connector symbol on the device side is shown, and for an intermediate connector, the male connector symbol is shown.</p> <p>For the connectors which are not connected to any appliance (spare terminal, terminal for inspection), the connectors at the harness side are shown.</p>
Connector connection marking	3	<p>Direct connection type</p>  <p>16A0339</p>		<p>A connection between a device and connector on the harness side is either by direct insertion in the device (direct connection type) or by connection with a harness connector furnished on the device side (harness connection type). The two types are indicated as illustrated.</p>
	4	<p>Harness connection type</p>  <p>16A0334</p>		
	5	<p>Intermediate connector-</p>  <p>16A0339</p>		

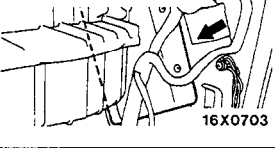

Item	No.	Connector / Grounding	Symbol	Contents
Grounding markings	6	Body ground  16X0701		Grounding is either by body ground, device ground or control unit interior ground. These are indicated as illustrated.
	7	Device ground  16X0702		
	8	Ground in control unit  16X0703		

**WIRE COLOR CODES**

Wire colors are identified by the following color codes.

Code	Wire color	Code	Wire color
B	Black	P	Pink
BR	Brown	R	Red
G	Green	SB	Sky blue
GR	Gray	v	Violet
L	Blue	W	White
LG	Light green	Y	Yellow
O	Orange		

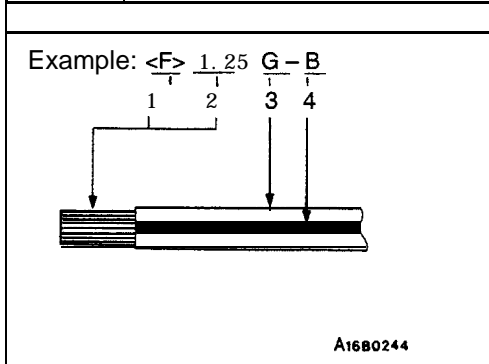

If a cable has two colors, the first of the two color code characters indicates the basic color (color of the cable coating) and the second indicates the marking color.

No.	Meaning
1	<F>: Flexible wire
	<T>: Twisted wire
2	Wire size (mm <sup>2</sup> )
3	Basic color (color of the cable coating)
4	Marking color

**NOTE**

\*: No code indicates 0.5 mm<sup>2</sup> (.0008 in.<sup>2</sup>).  
Cable color code in parentheses indicates 0.3 mm<sup>2</sup> (.0005 in.<sup>2</sup>).

# POWER DISTRIBUTION COMPONENT LOCATION

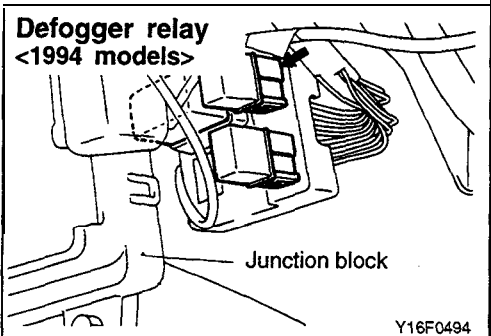
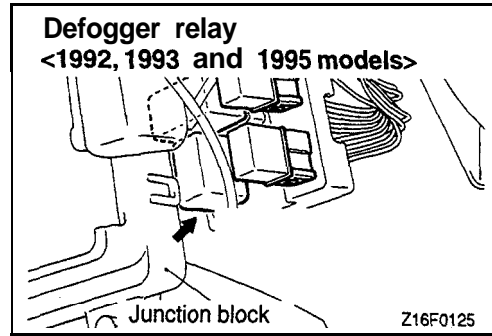
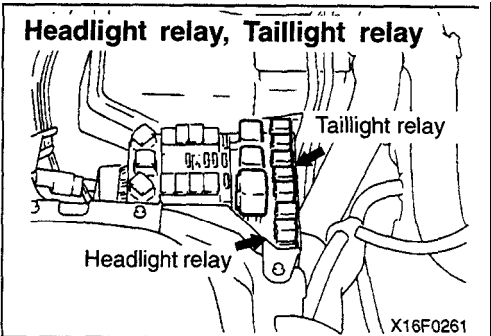
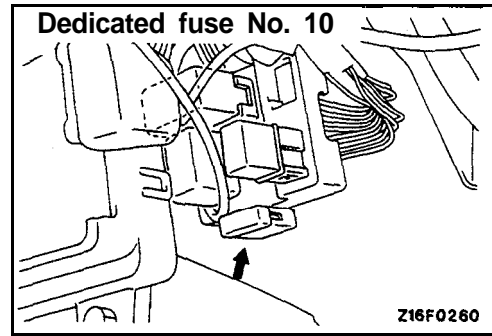
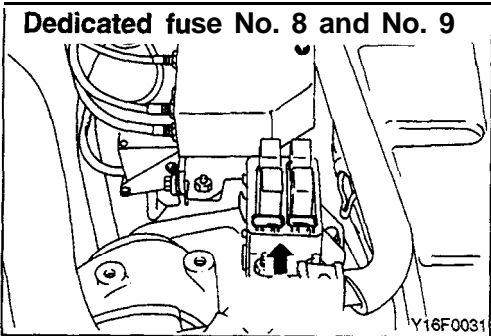
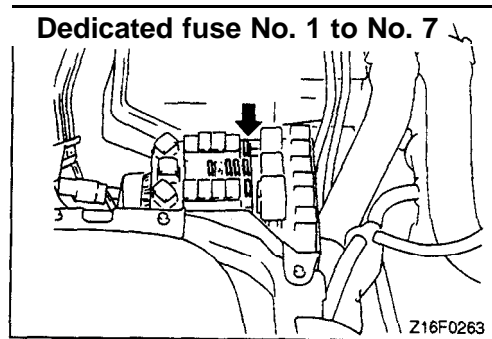
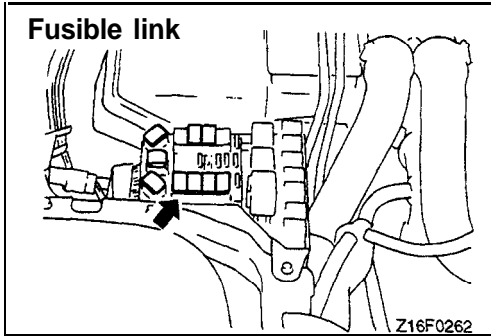

**POWER DISTRIBUTION CIRCUIT  
(UP TO 1993 MODELS)**

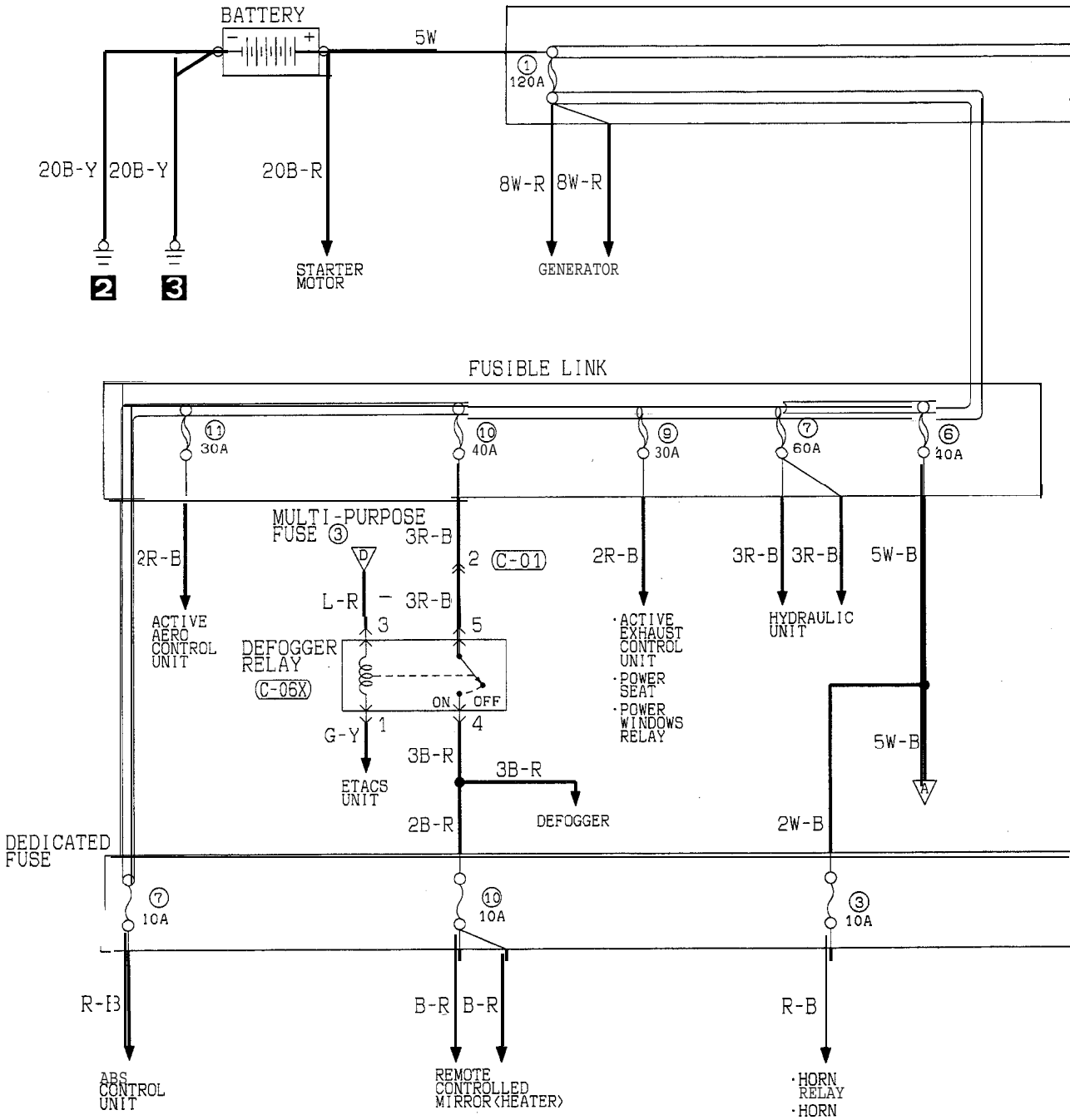

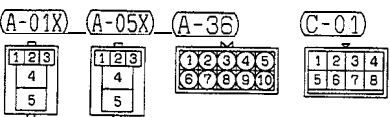
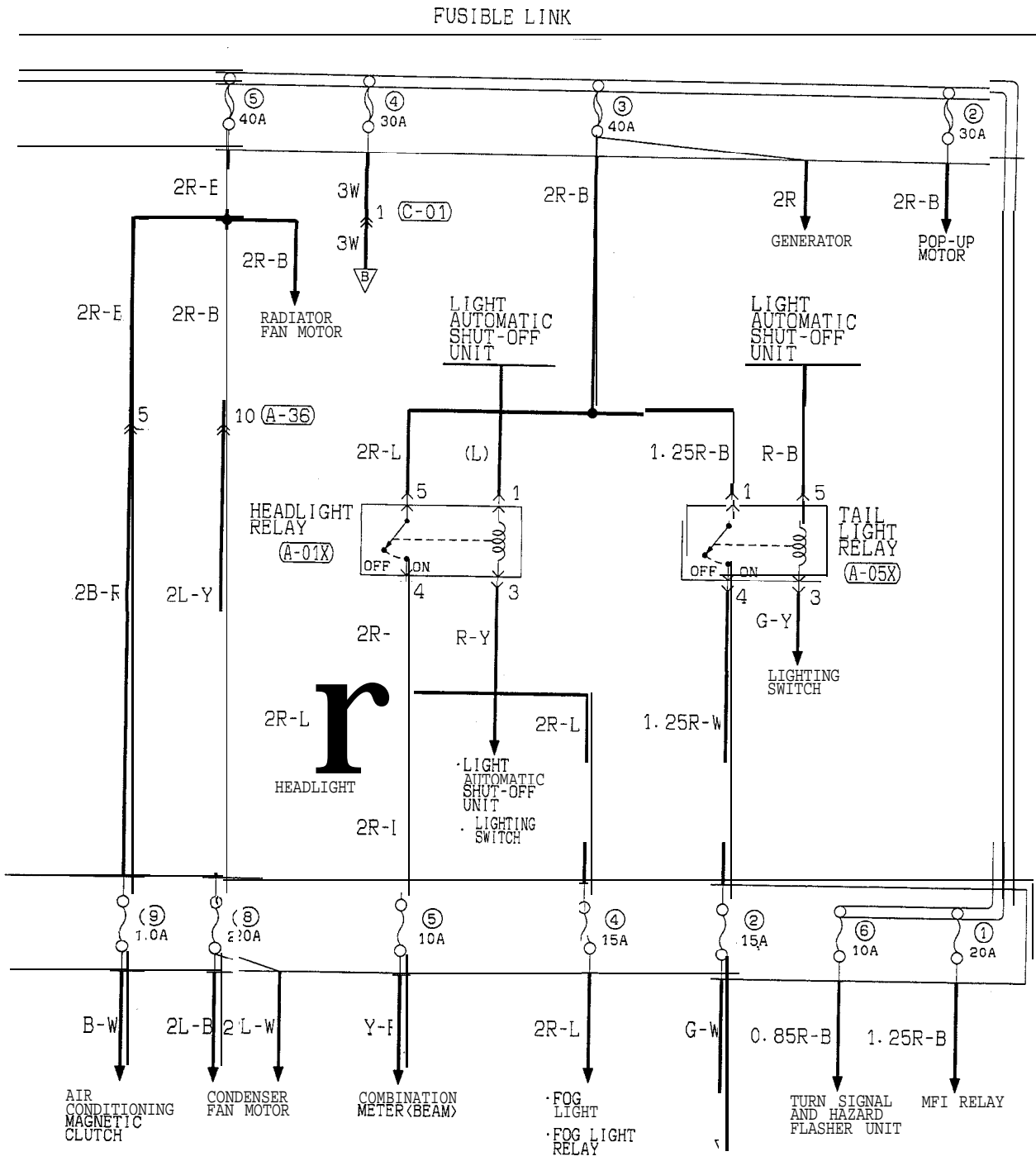

TSB Revision

POWER DISTRIBUTION CIRCUIT (UP TO 1993 MODELS) (CONTINUED)

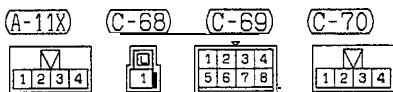
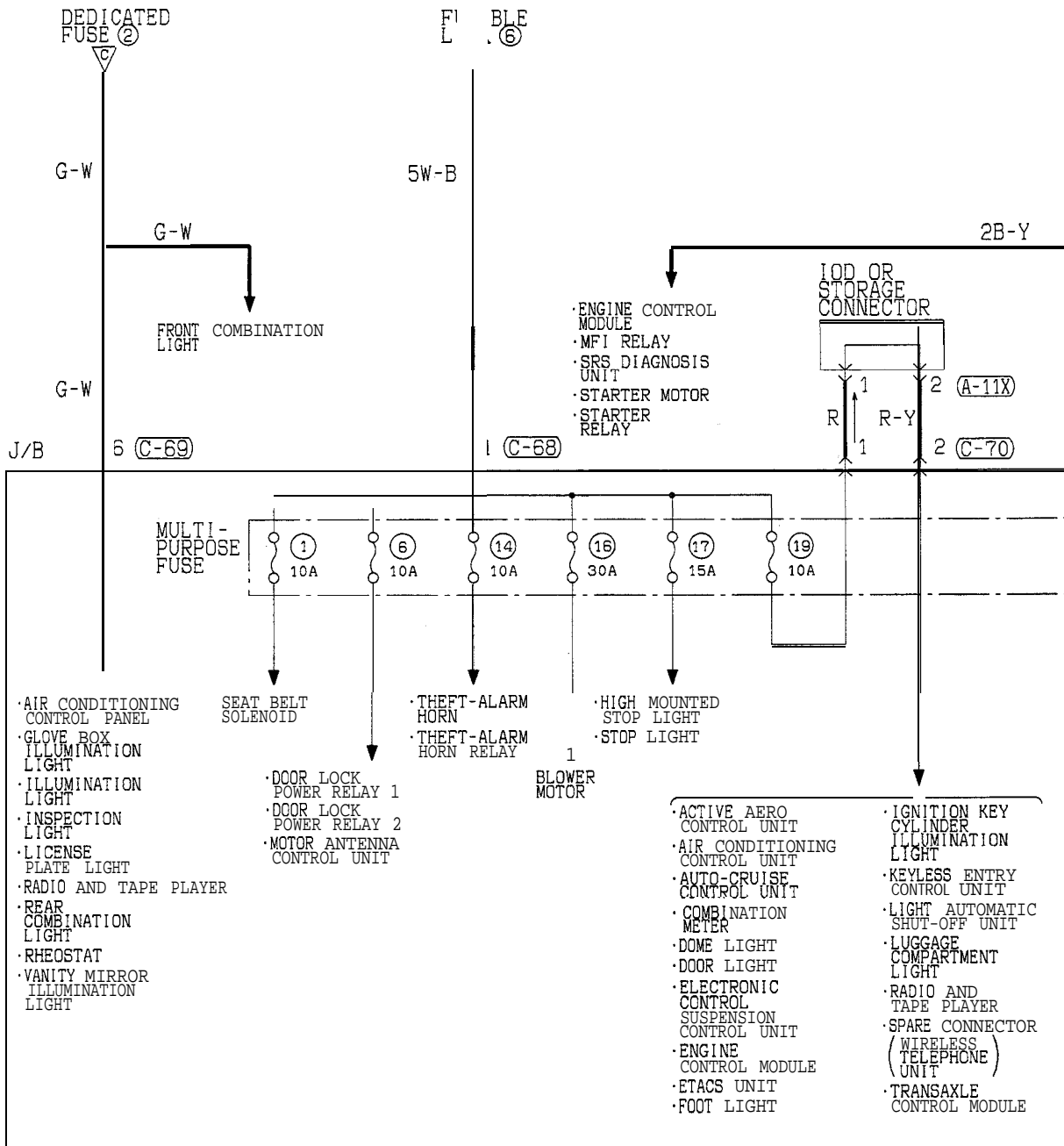

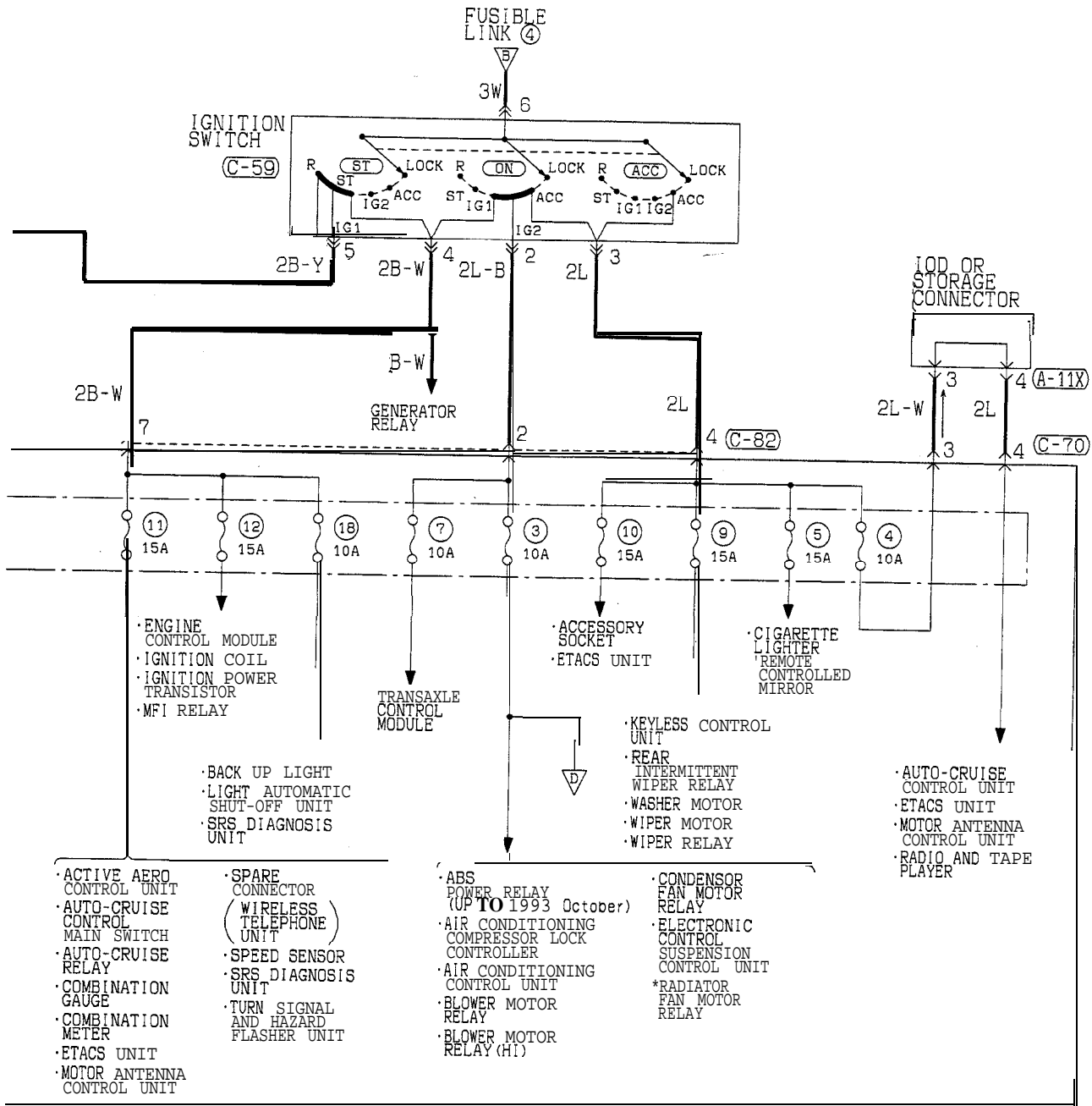

REMARK  
 THE ABOVE CIRCUIT DIAGRAM SHOWS THE CURRENT FLOW AT THE IGNITION KEY POSITION "ACC", "ON" AND "ST" COMBINED. BE SURE TRACE THE APPROPRIATE CIRCUIT DEPENDING ON THE IGNITION KEY POSITION.

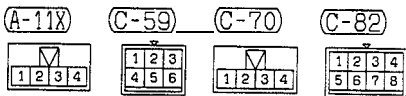

TSB Revision

**POWER DISTRIBUTION CIRCUIT  
(1994 MODELS)**

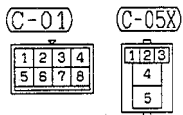
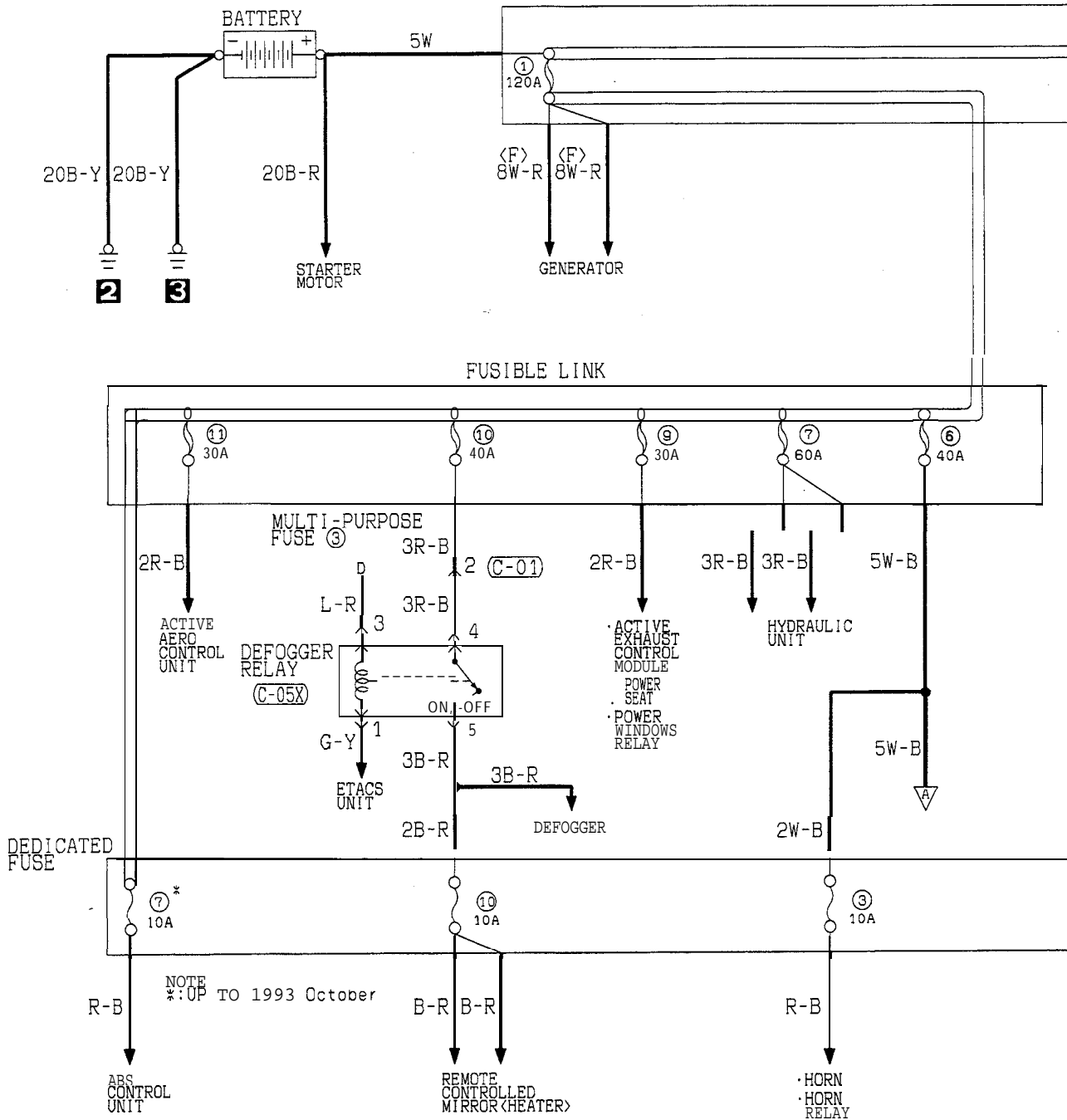

NOTE  
\*: OP TO 1993 October

TSB Revision

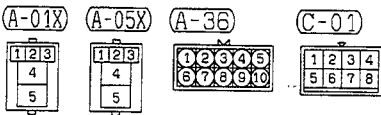
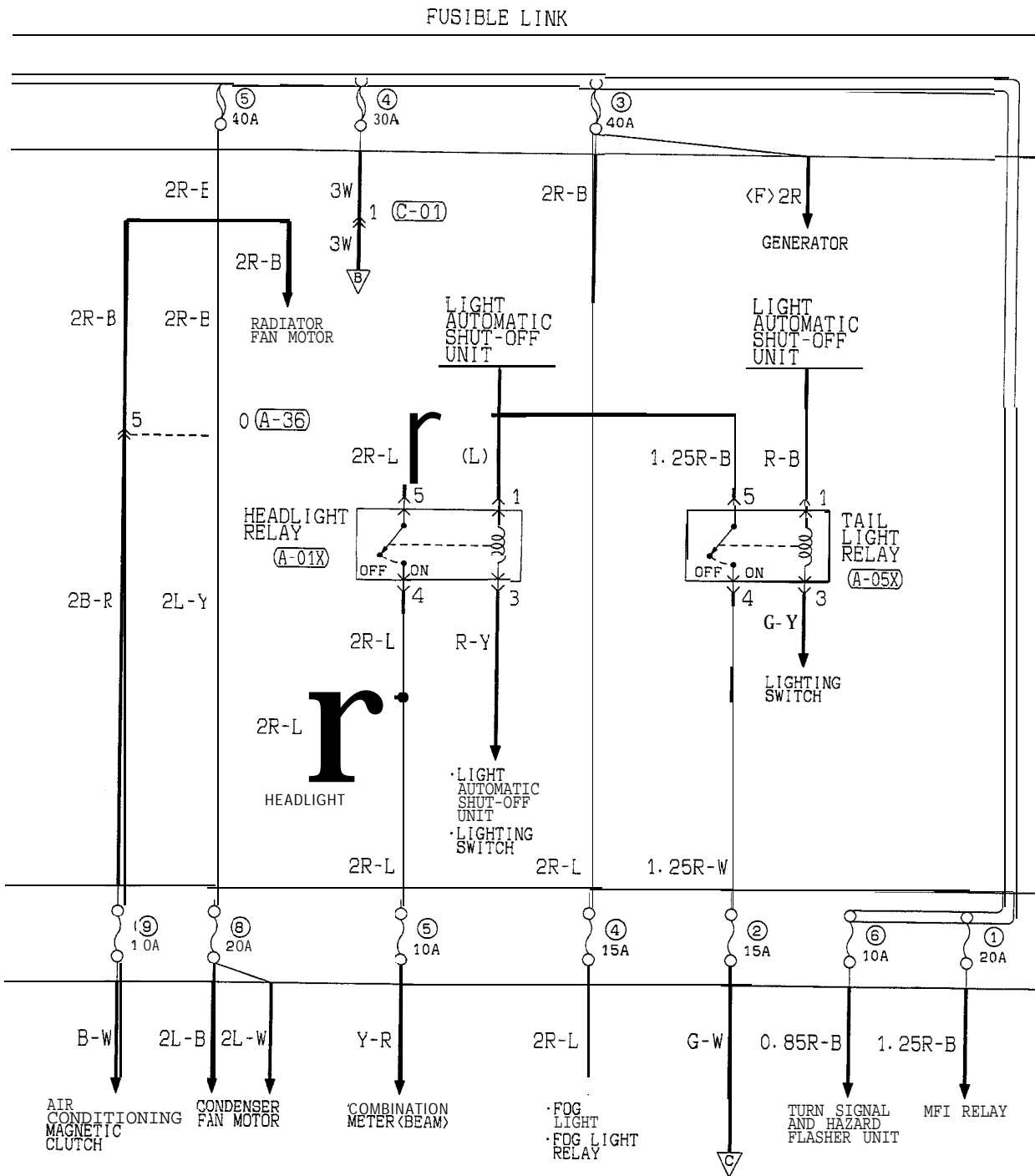



POWER DISTRIBUTION CIRCUIT (1994 MODELS) (CONTINUED)

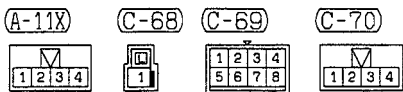
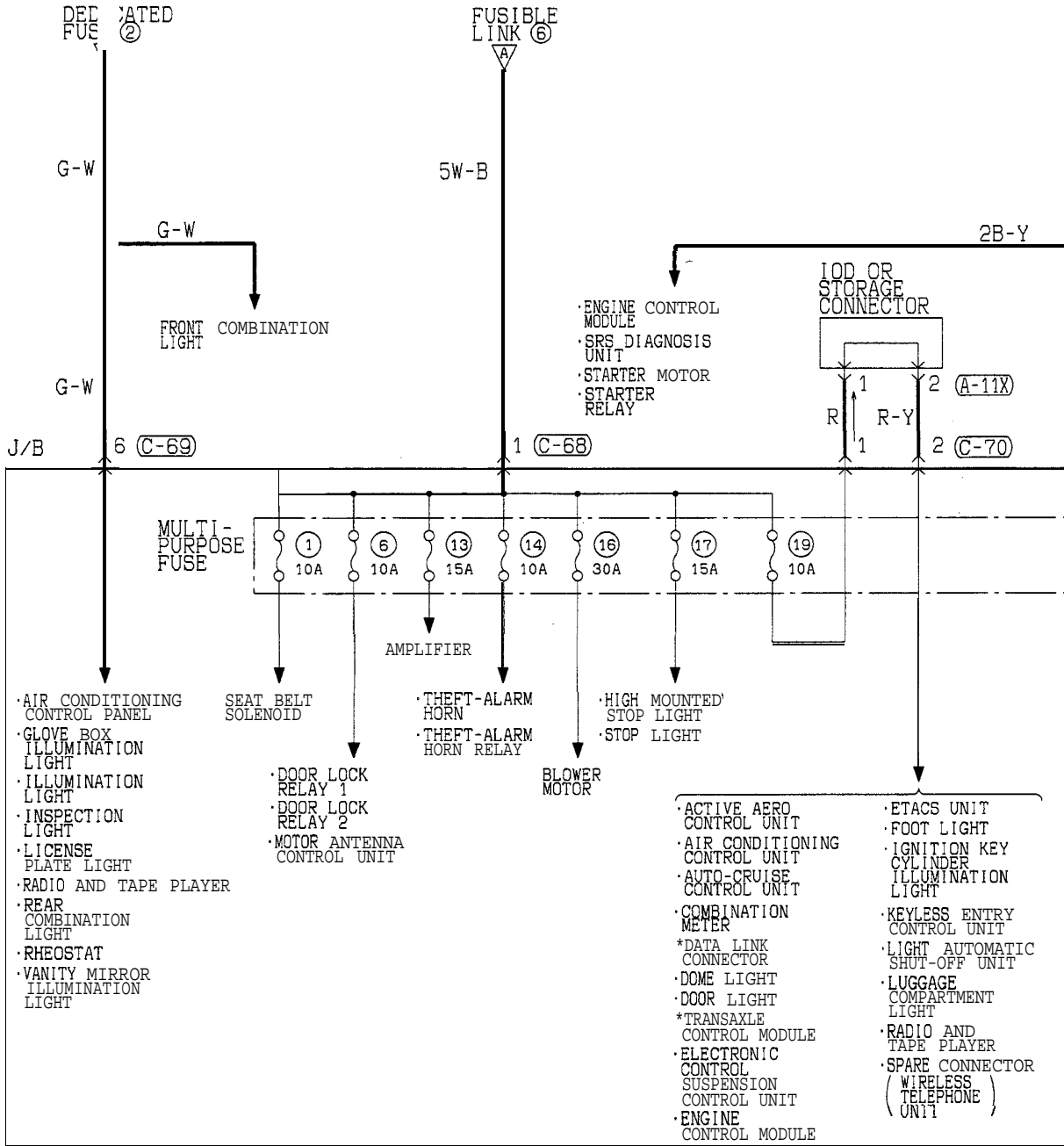

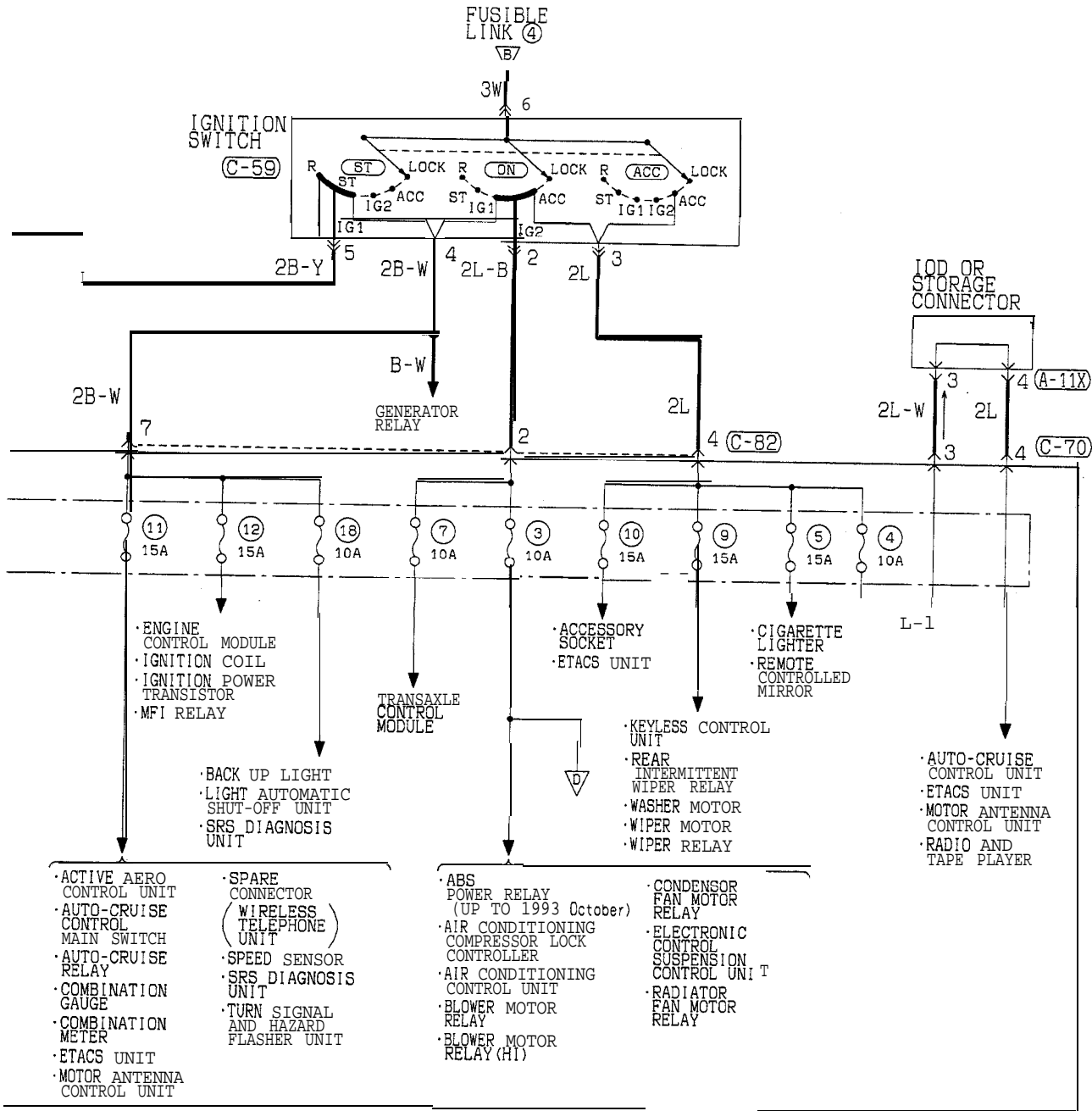

REMARK  
 THE ABOVE CIRCUIT DIAGRAM SHOWS THE CURRENT FLOW AT THE IGNITION KEY POSITION "ACC", "ON" AND "ST" COMBINED. BE SURE TRACE THE APPROPRIATE CIRCUIT DEPENDING ON THE IGNITION KEY POSITION.

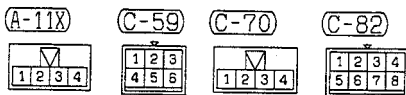

**POWER DISTRIBUTION CIRCUIT  
(1995 MODELS)**

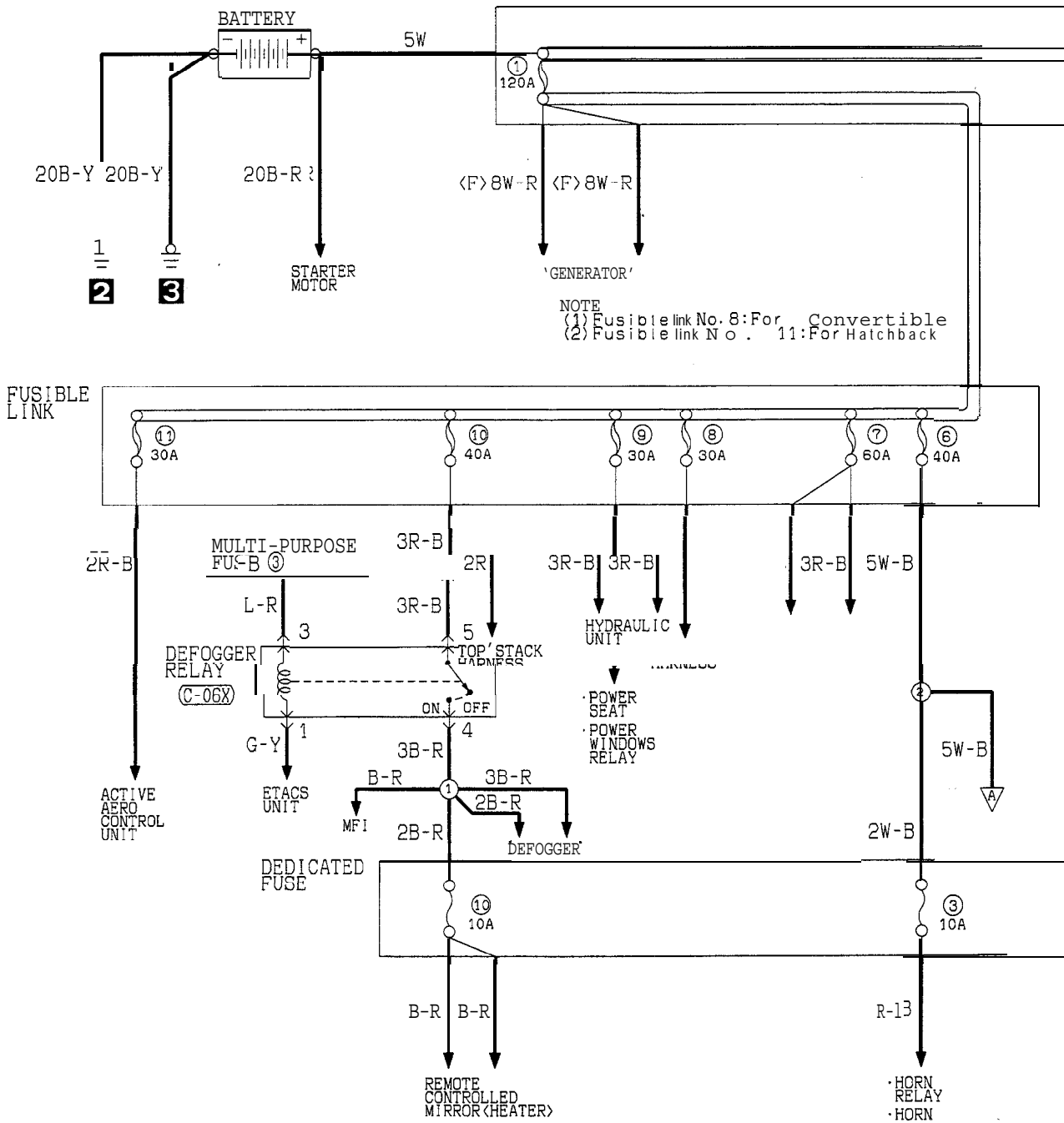

C-01

C-06X



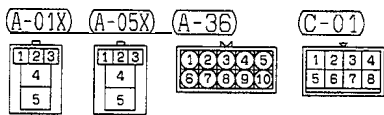
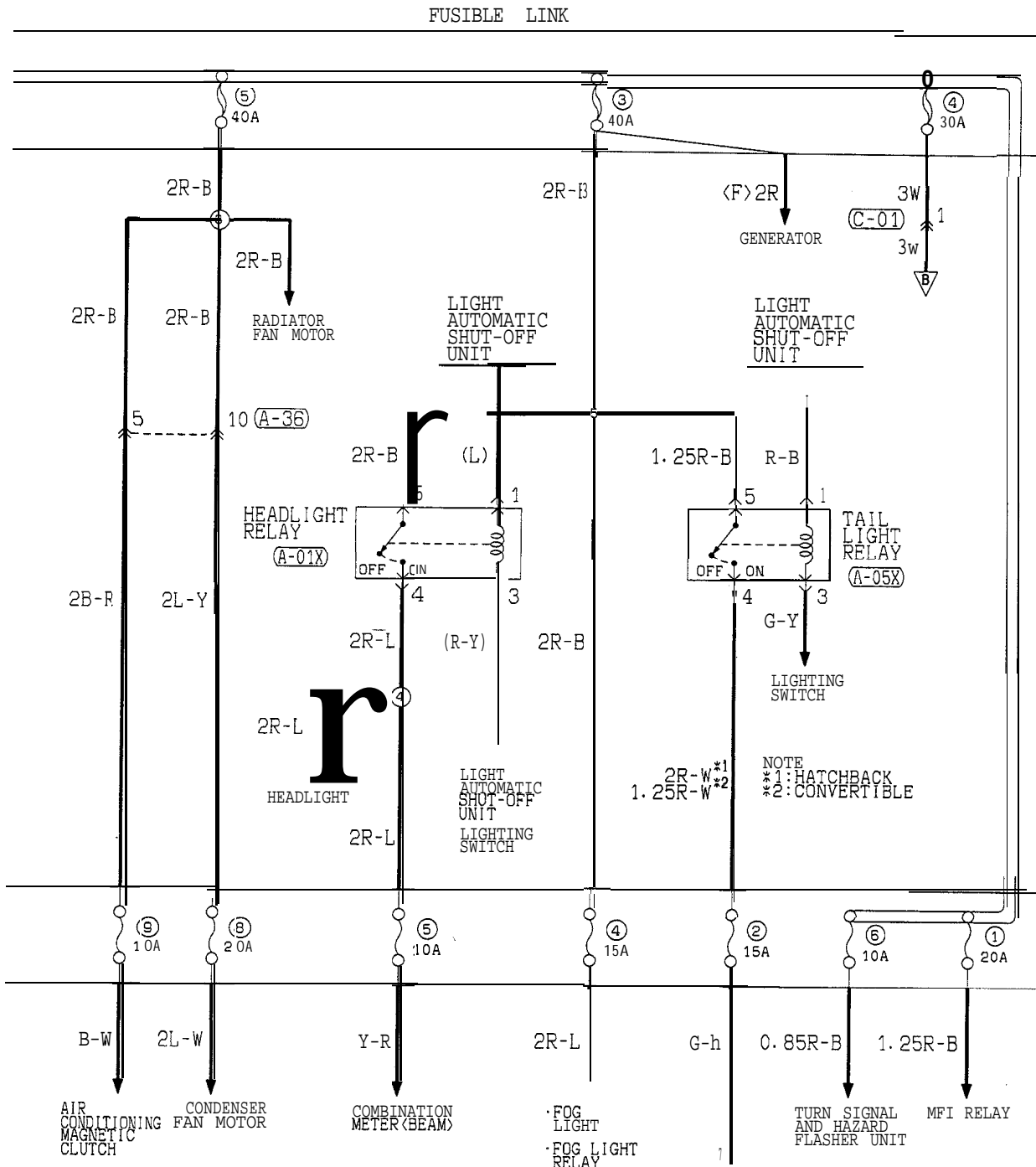

POWER DISTRIBUTION CIRCUIT (1995 MODELS) (CONTINUED)

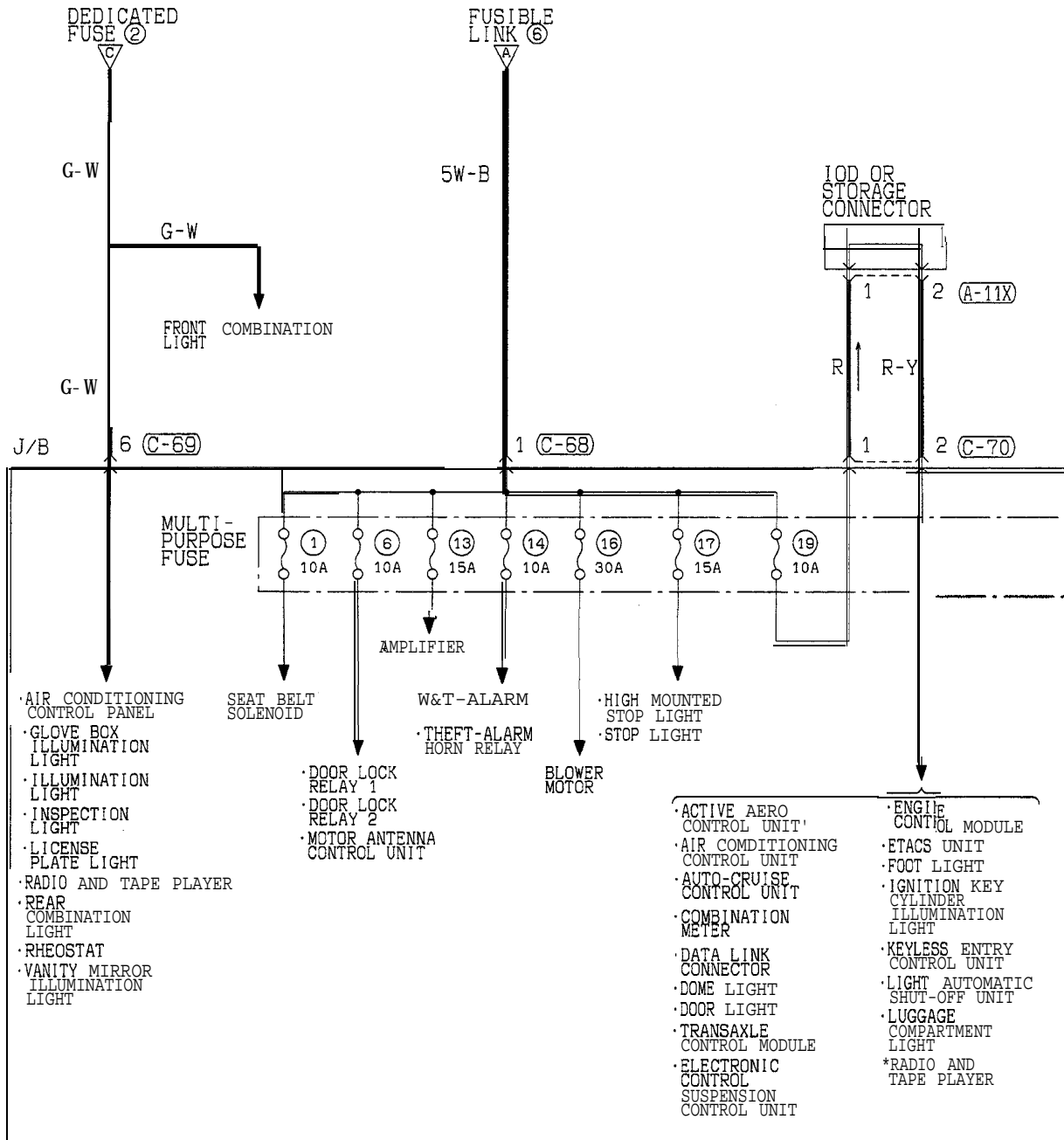

NOTE  
\* : HATCHBACK

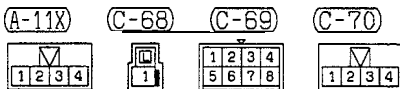

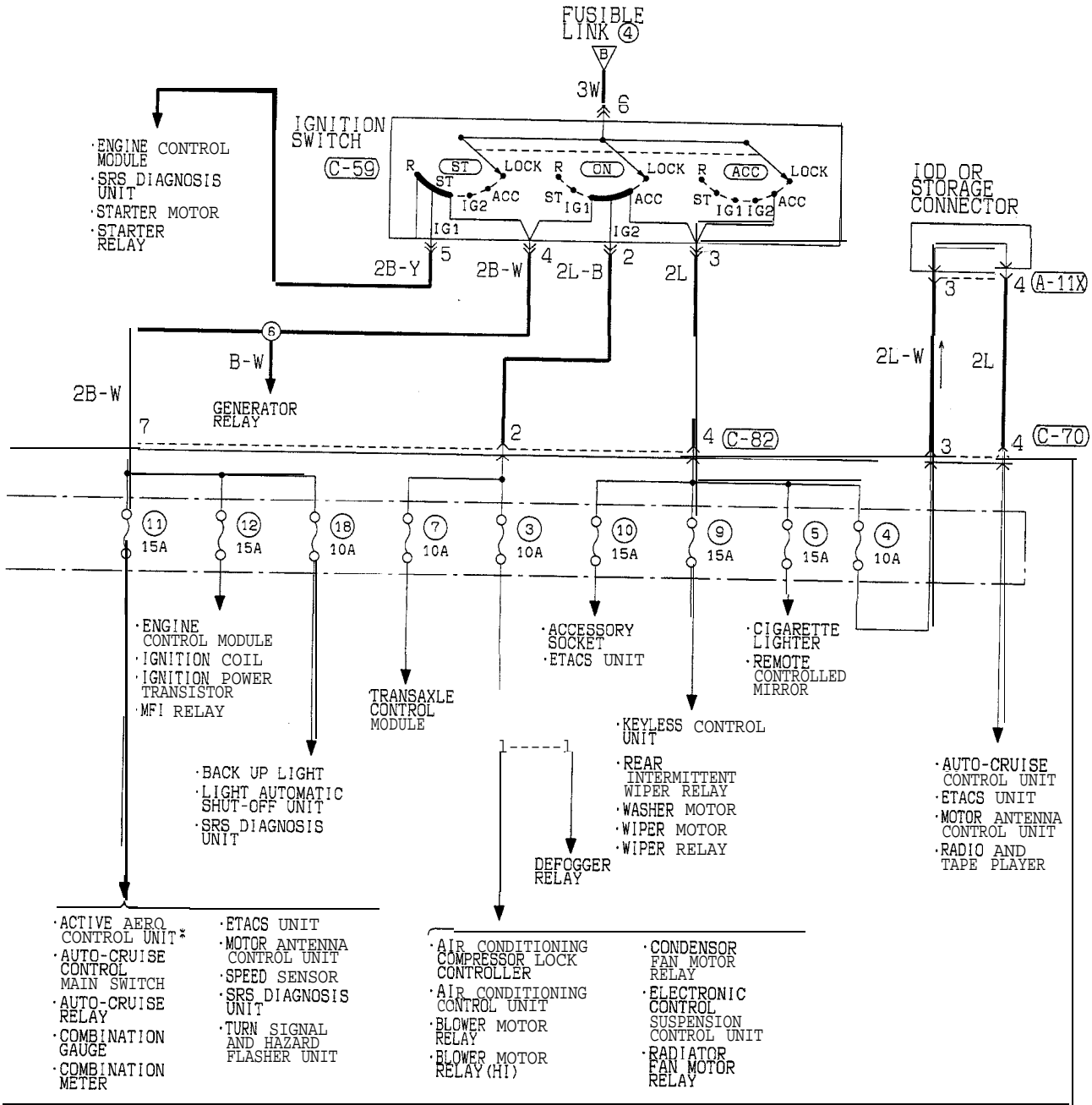

NOTE  
THE ABOVE CIRCUIT DIAGRAM SHOWS THE CURRENT FLOW AT THE IGNITION KEY POSITION "ACC", "ON" AND "ST" COMBINED. BE SURE TRACE THE APPROPRIATE CIRCUIT DEPENDING ON THE IGNITION KEY POSITION.

\*: HATCHBACK

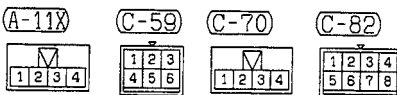

**POWER DISTRIBUTION CIRCUIT  
(FROM 1996 MODELS)**

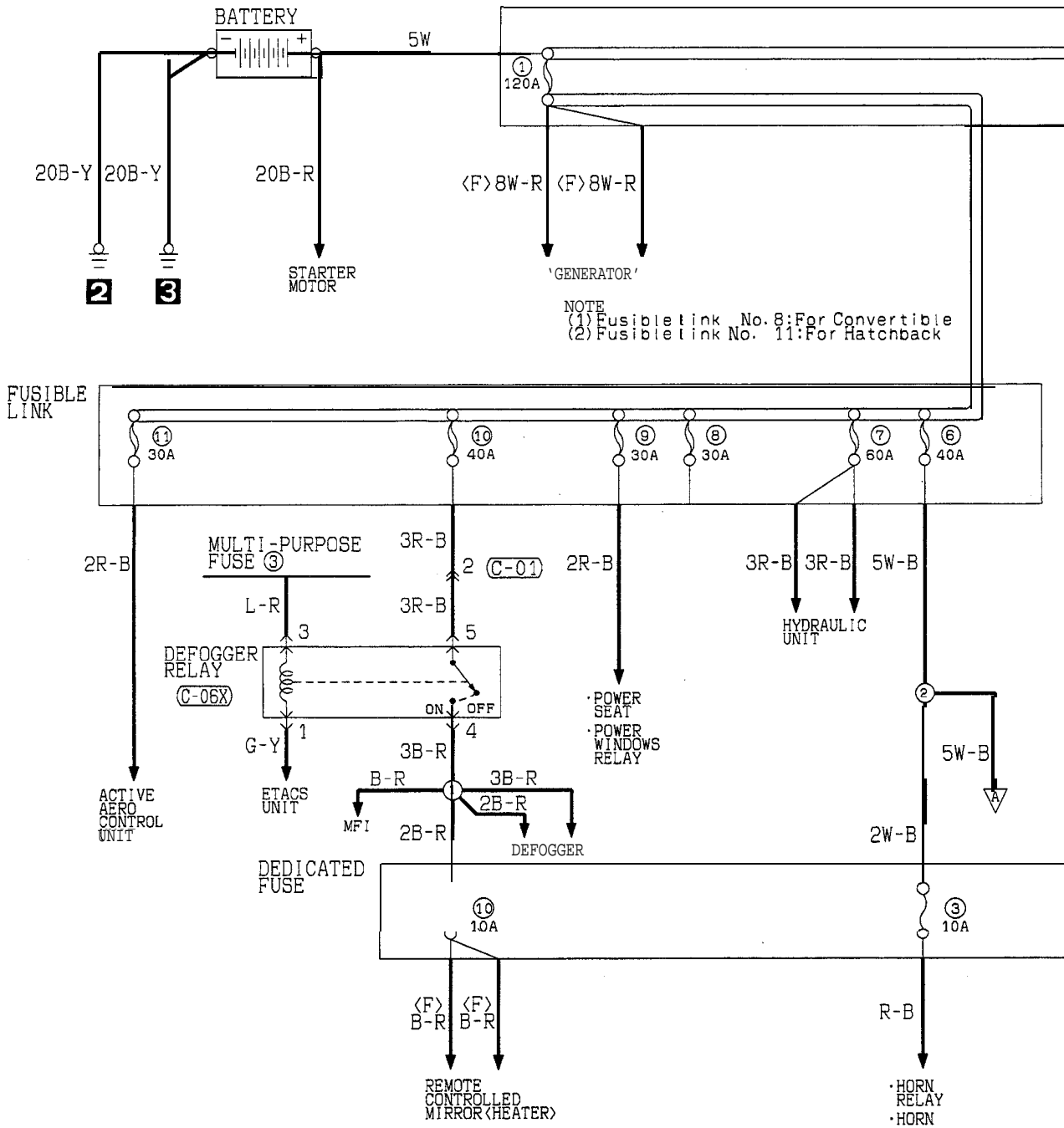

NOTE  
 (1) Fusible link No. 8: For Convertible  
 (2) Fusible link No. 11: For Hatchback

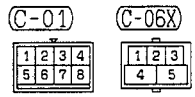

TSB Revision

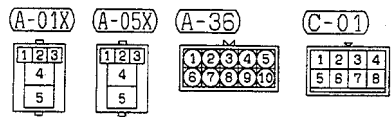
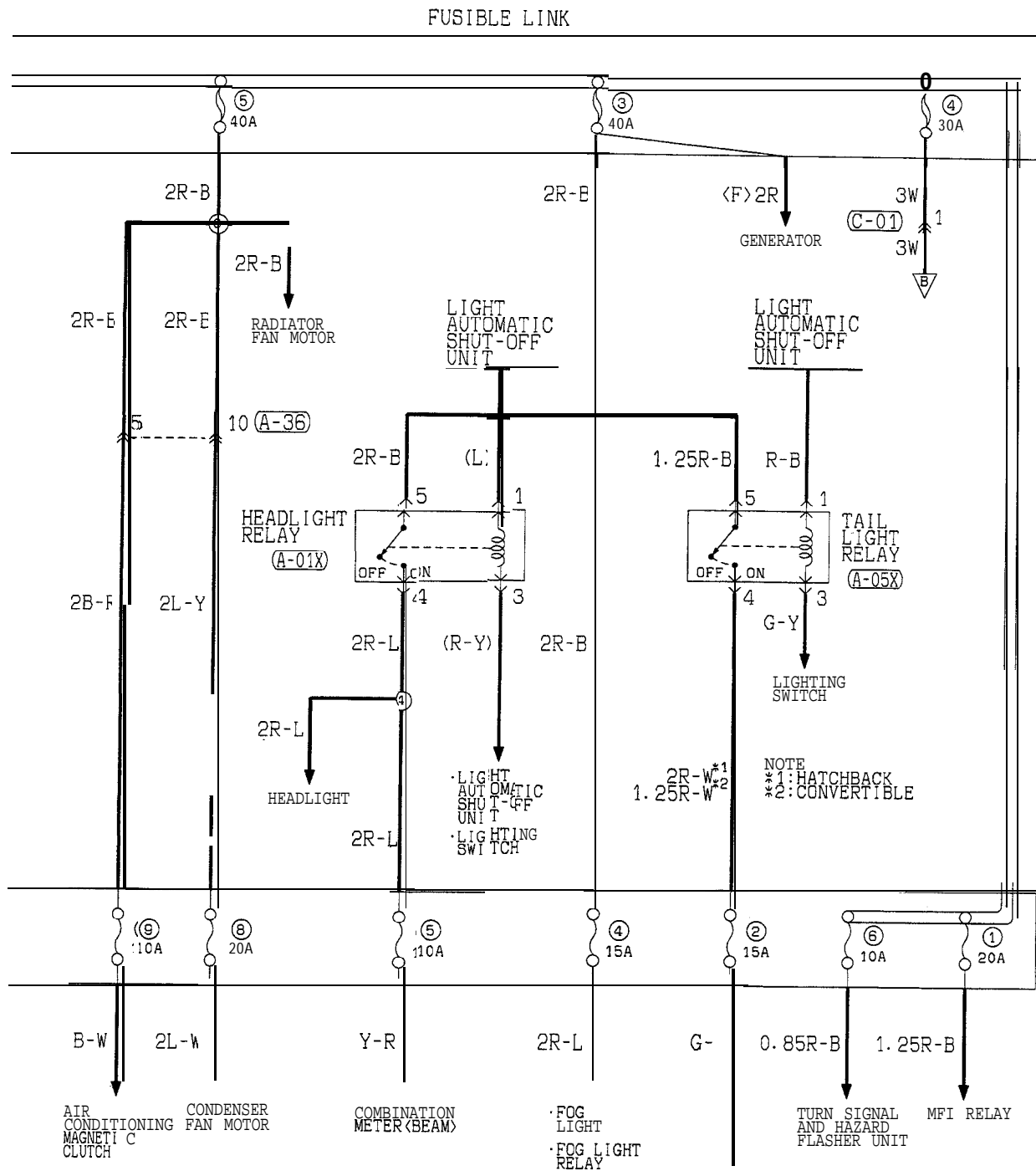



POWER DISTRIBUTION CIRCUIT (FROM 1996 MODELS) (CONTINUED)

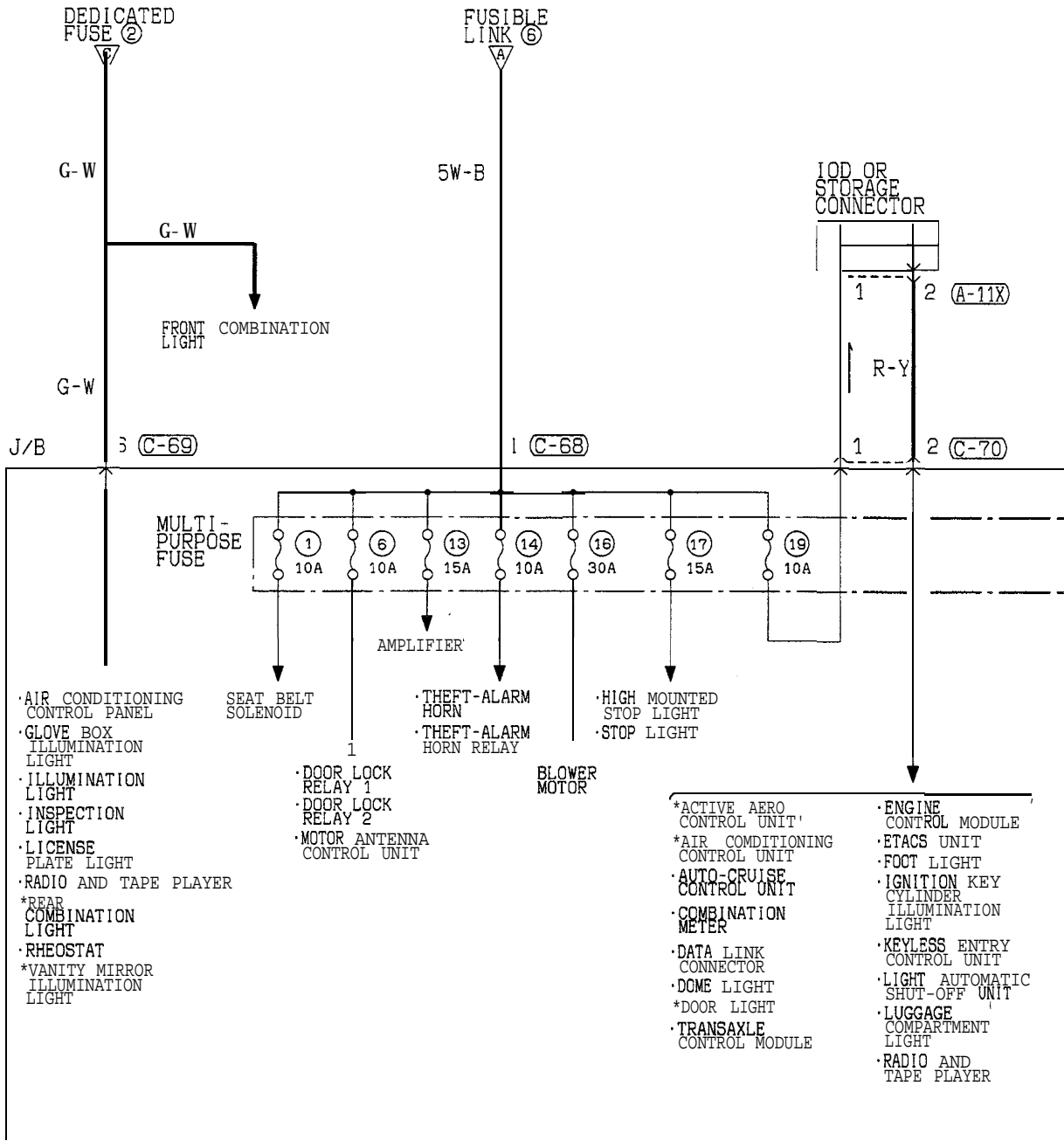

NOTE  
\*: HATCHBACK

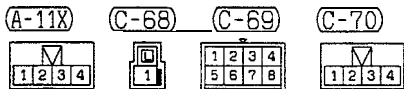

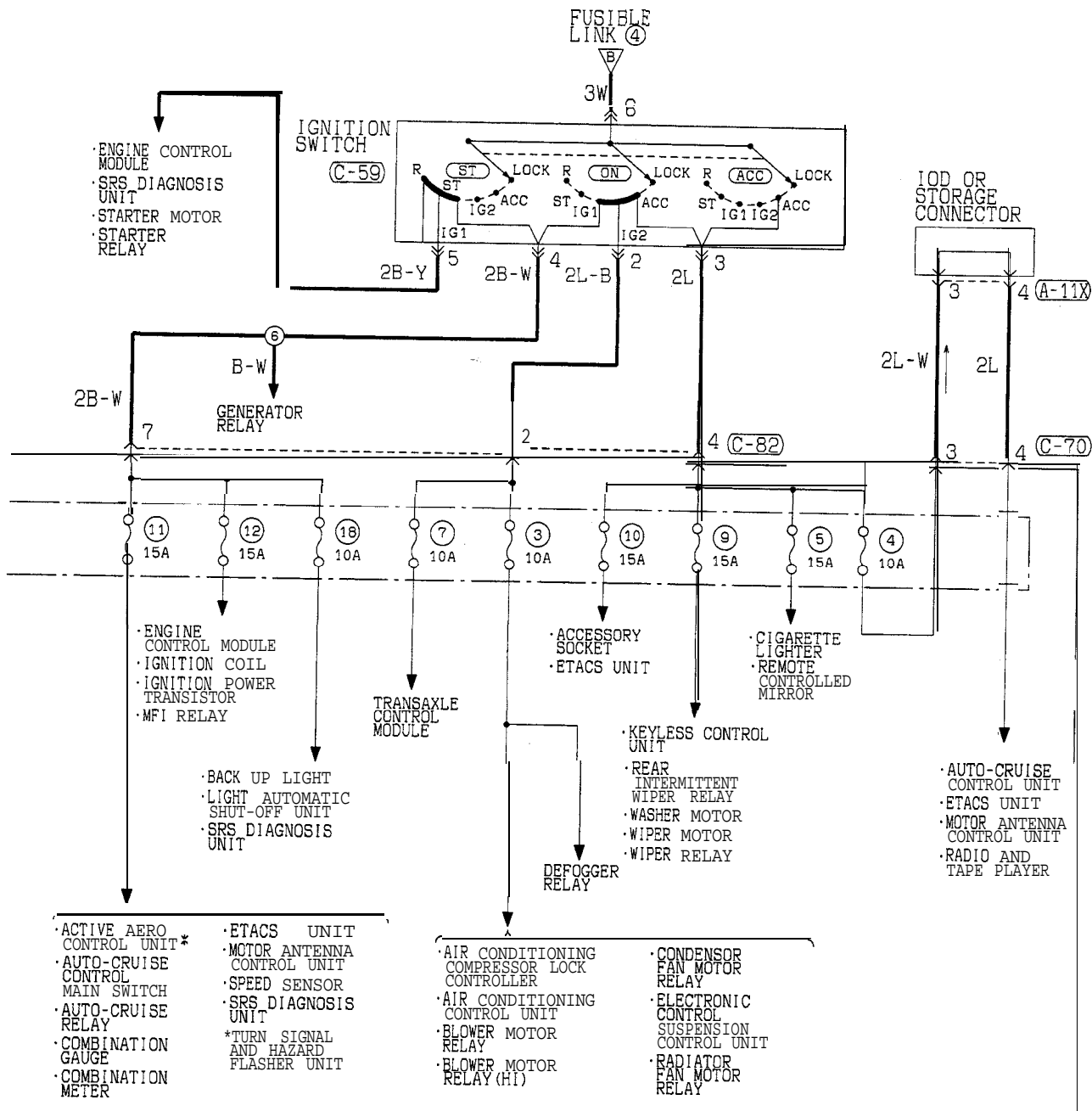

NOTE  
 THE ABOVE CIRCUIT DIAGRAM SHOWS THE CURRENT FLOW AT THE IGNITION KEY POSITION "ACC", "ON" AND "ST" COMBINED. BE SURE TRACE THE APPROPRIATE CIRCUIT DEPENDING ON THE IGNITION KEY POSITION.

\*: HATCHBACK

(A-11X)

(C-59)

(C-70)

(C-82)



MFI CIRCUIT (1992 MODEL)

<NON TURBO>

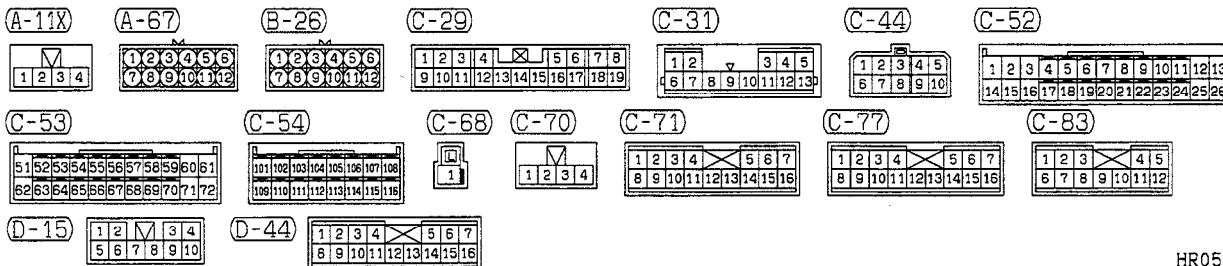
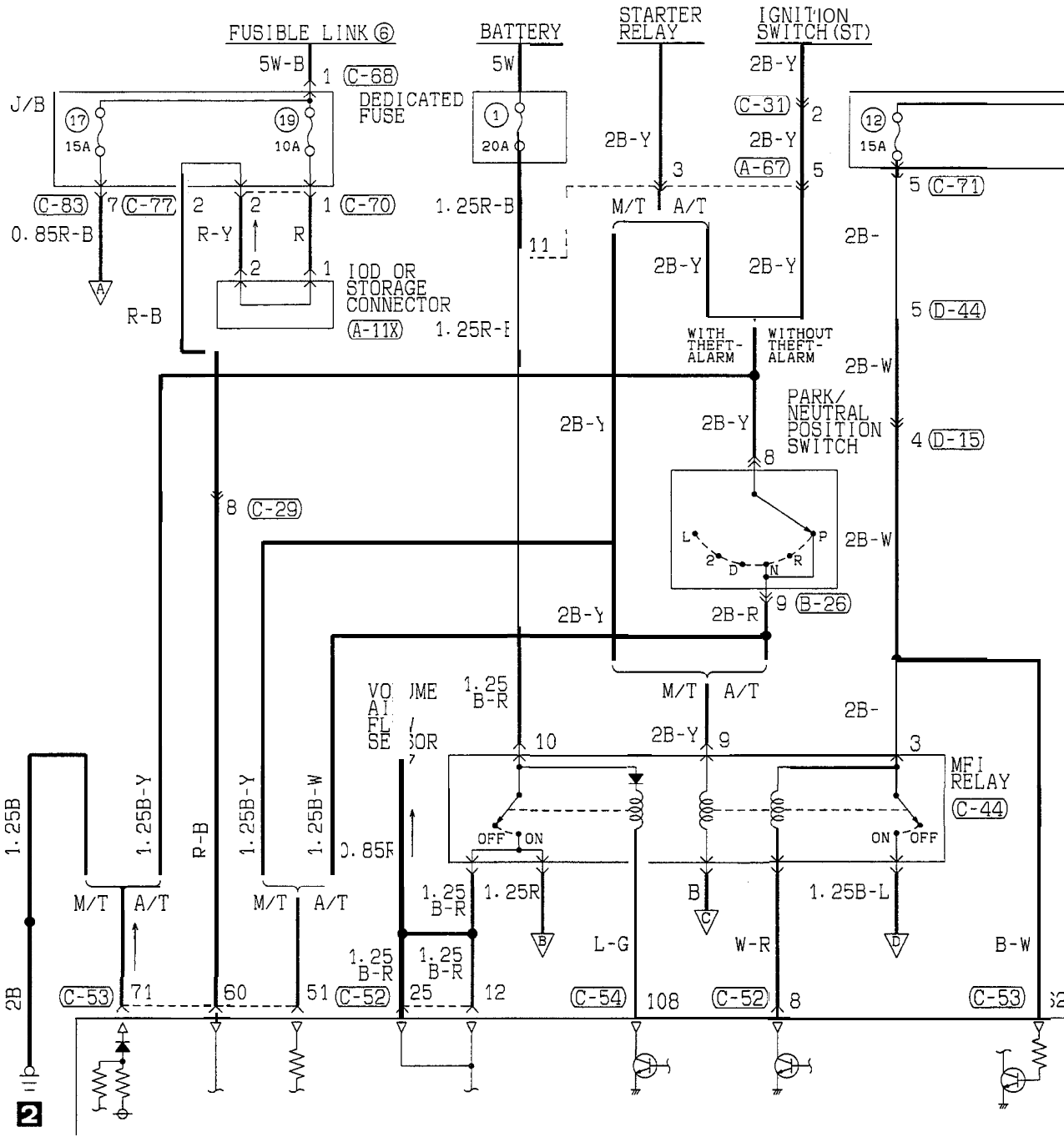

HR05M00AA

TSB Revision

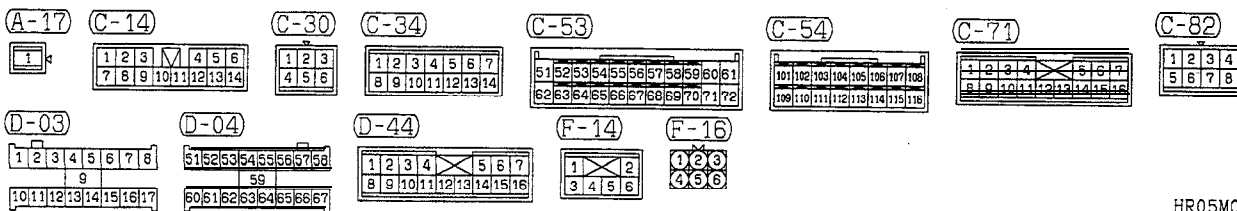
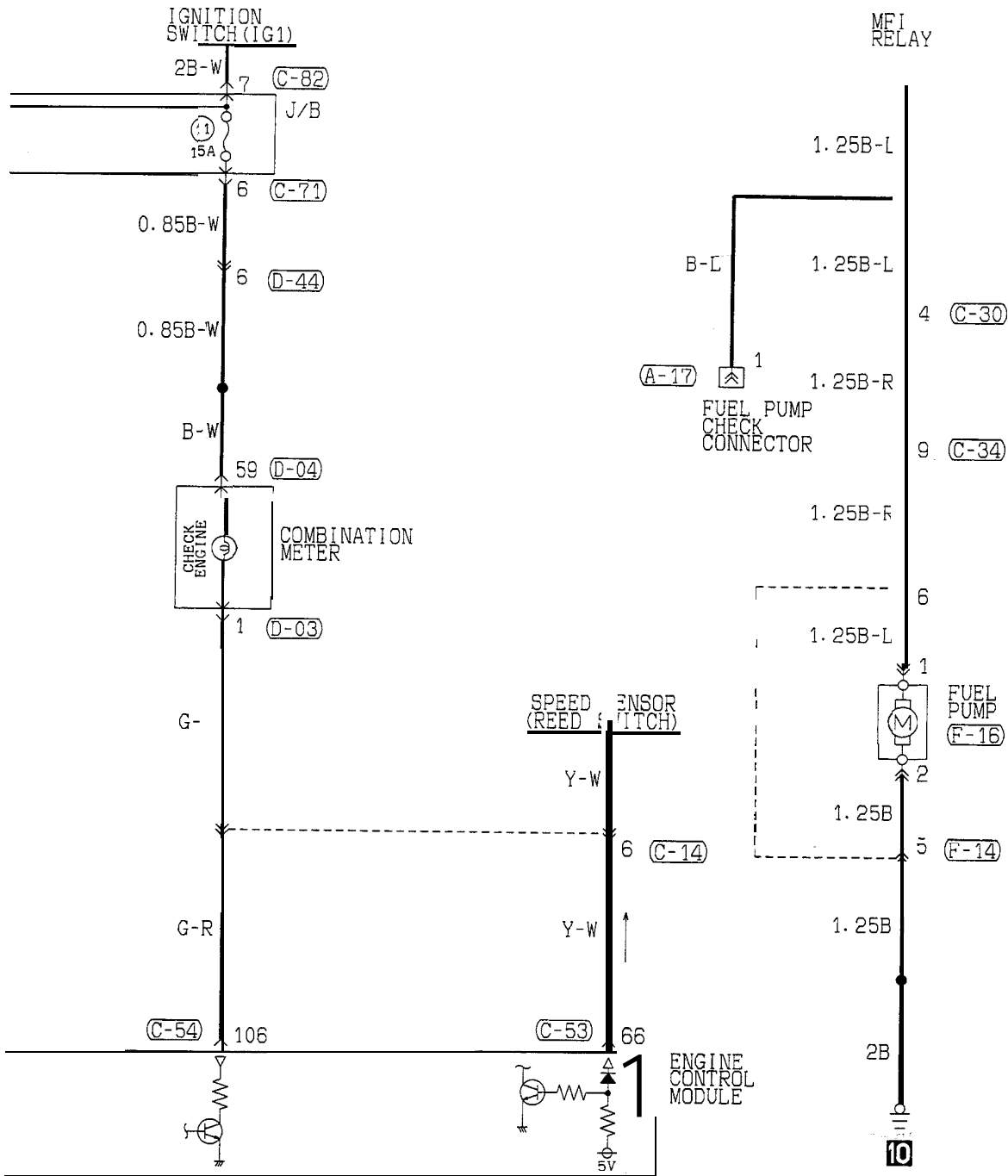

TSB Revision

MFI CIRCUIT (1992 MODEL) <NON TURBO> (CONTINUED)

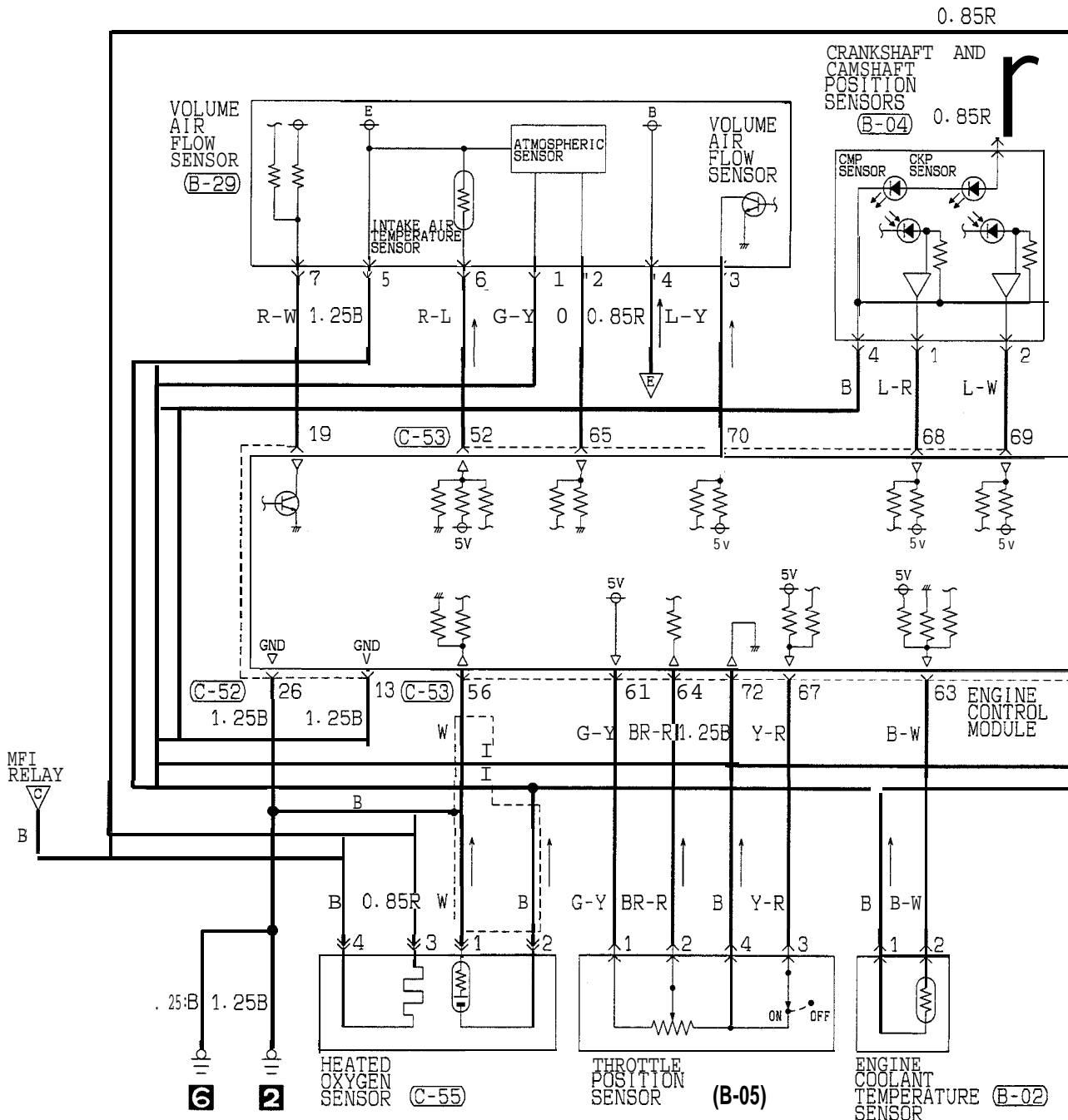

(B-02) (B-04) (B-05) (B-29)

(c-52)

(C-53)

(C-55)

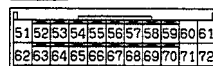

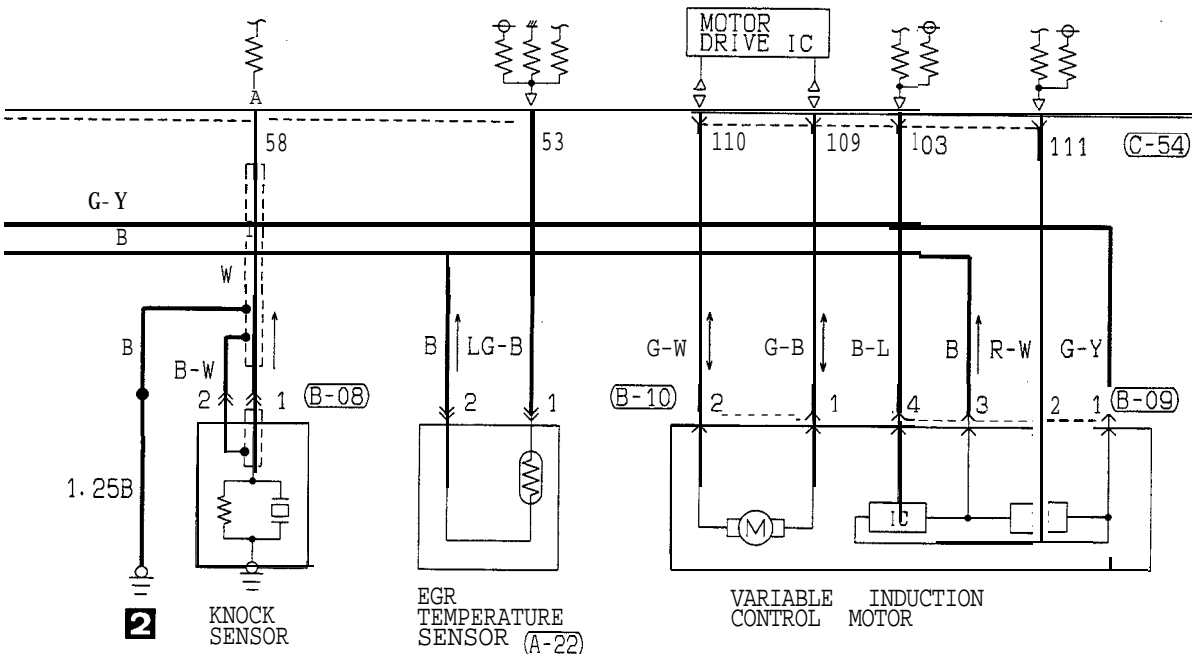
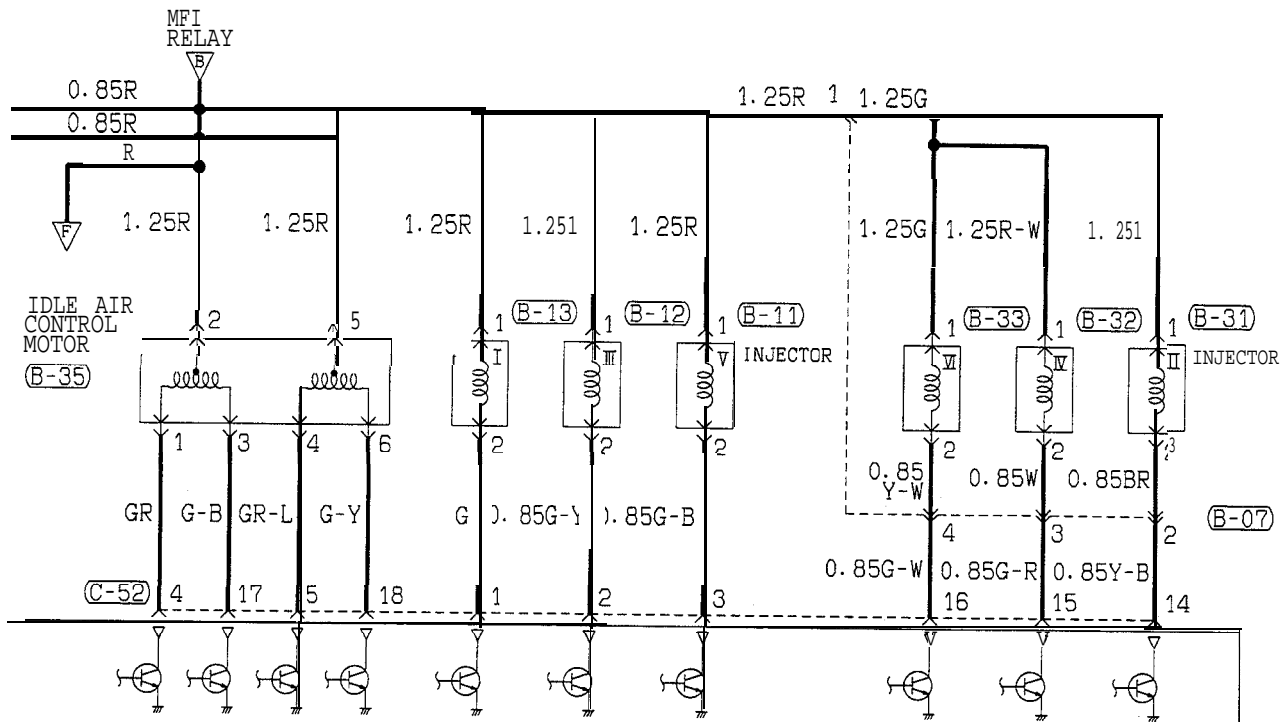

- (A-22)
- (B-07)
- (B-08)
- (B-09)
- (B-10)
- (B-11)
- (B-12)
- (B-13)
- (B-31)
- (B-32)
- (B-33)
- (B-35)

(C-52)

1	2	3	4	5	6	7	8	9	10	11	12	13
14	15	16	17	18	19	20	21	22	23	24	25	26

(C-54)

101	102	103	104	105	106	107	108
109	110	111	112	113	114	115	116

TSB Revision

MFI CIRCUIT (1992 MODEL) <NON TURBO> (CONTINUED)

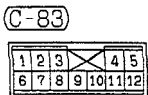
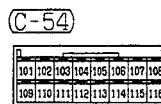
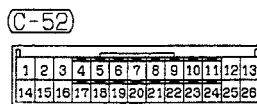
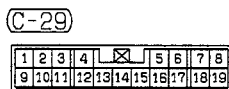
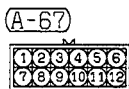
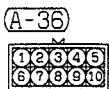
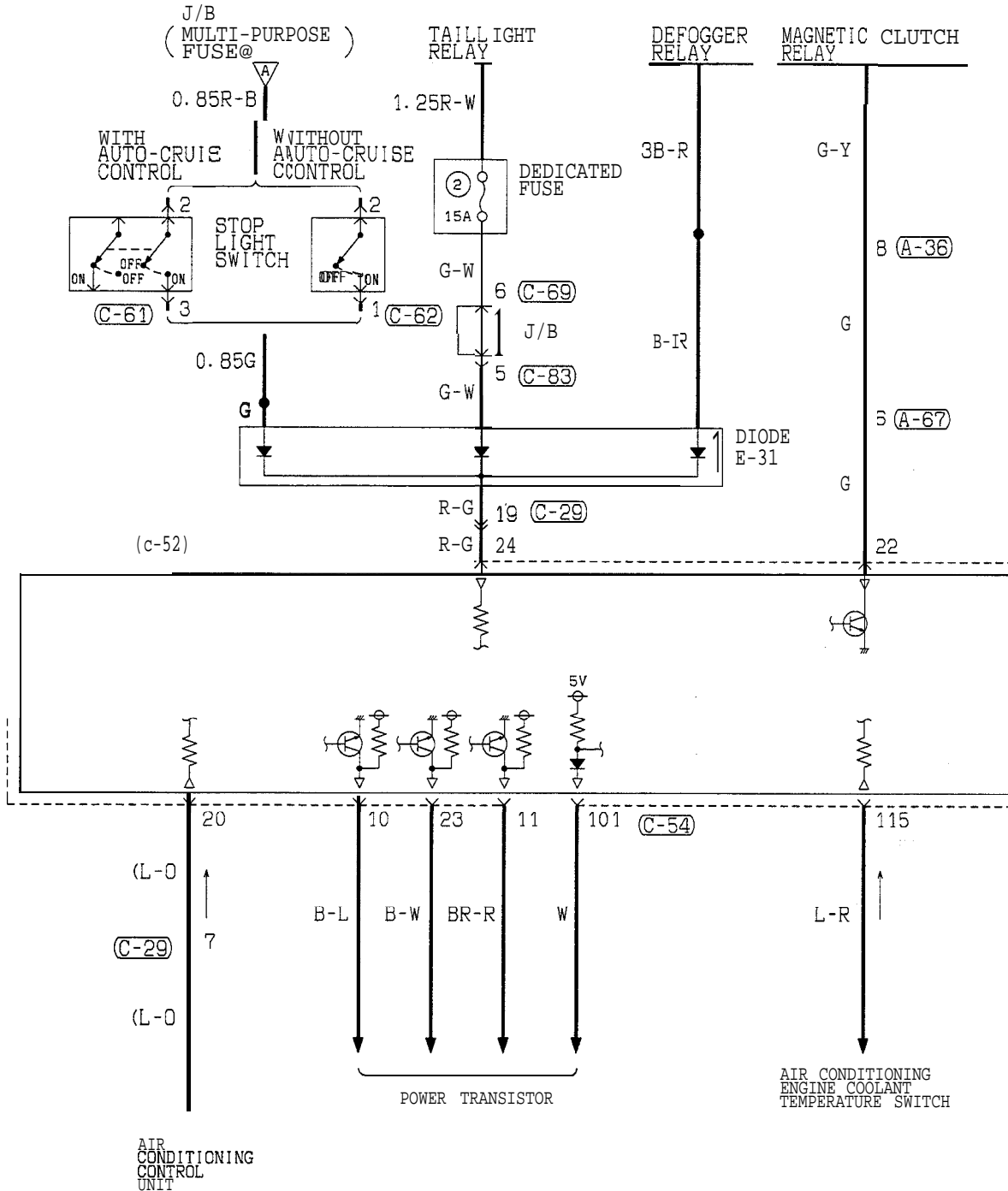

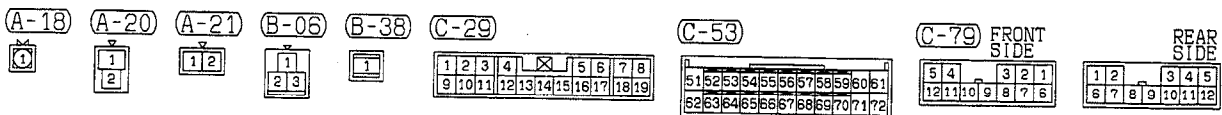
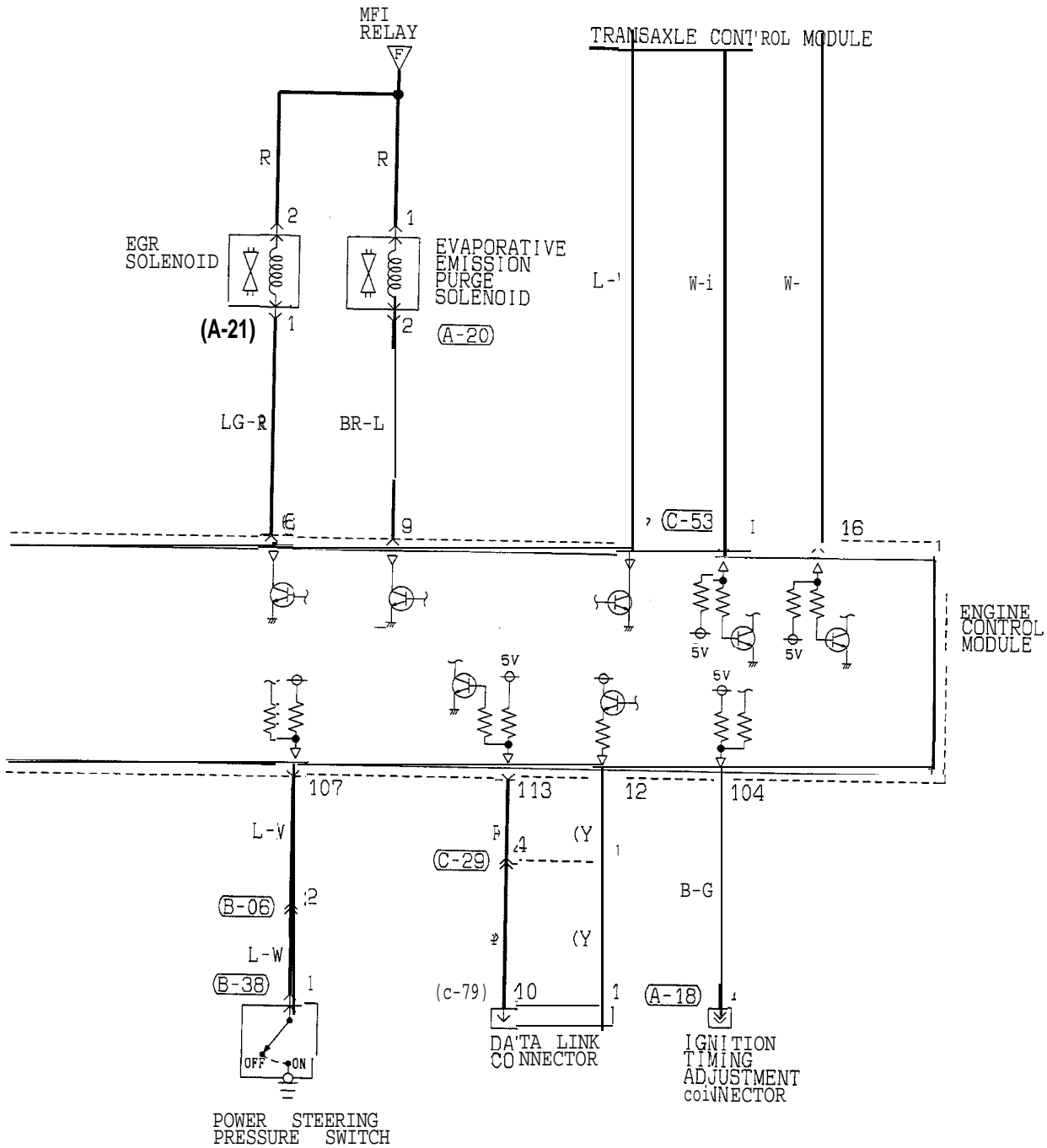



# MFI CIRCUIT (1992 MODEL)

<TURBO>

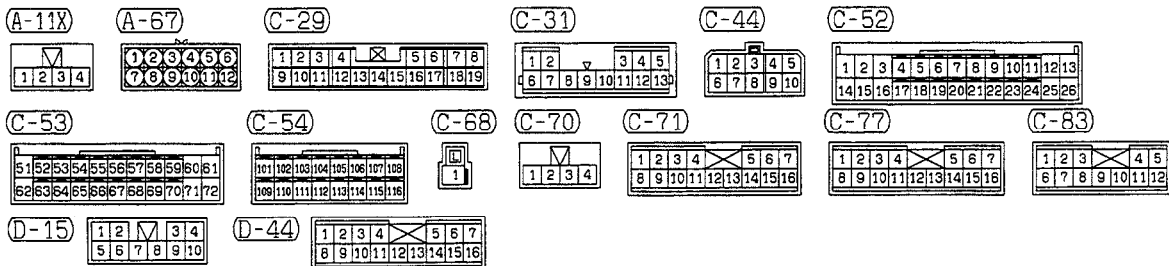
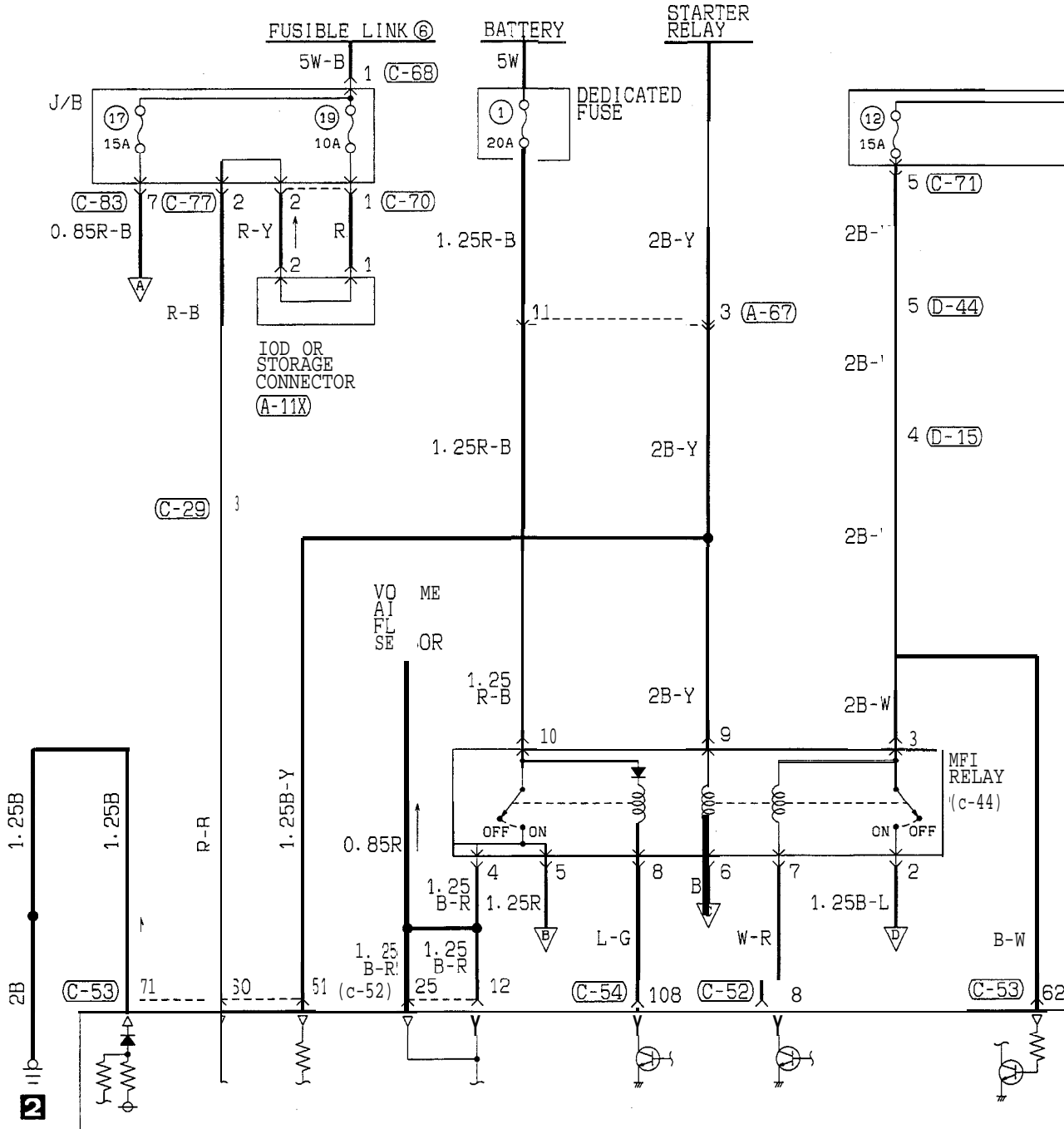

TSB Revision

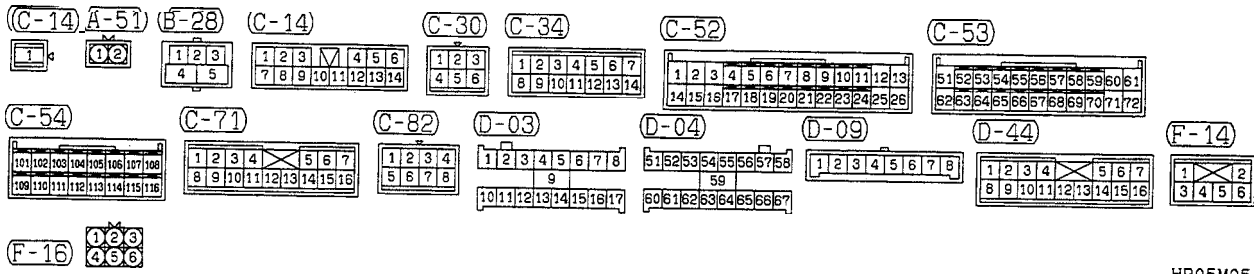
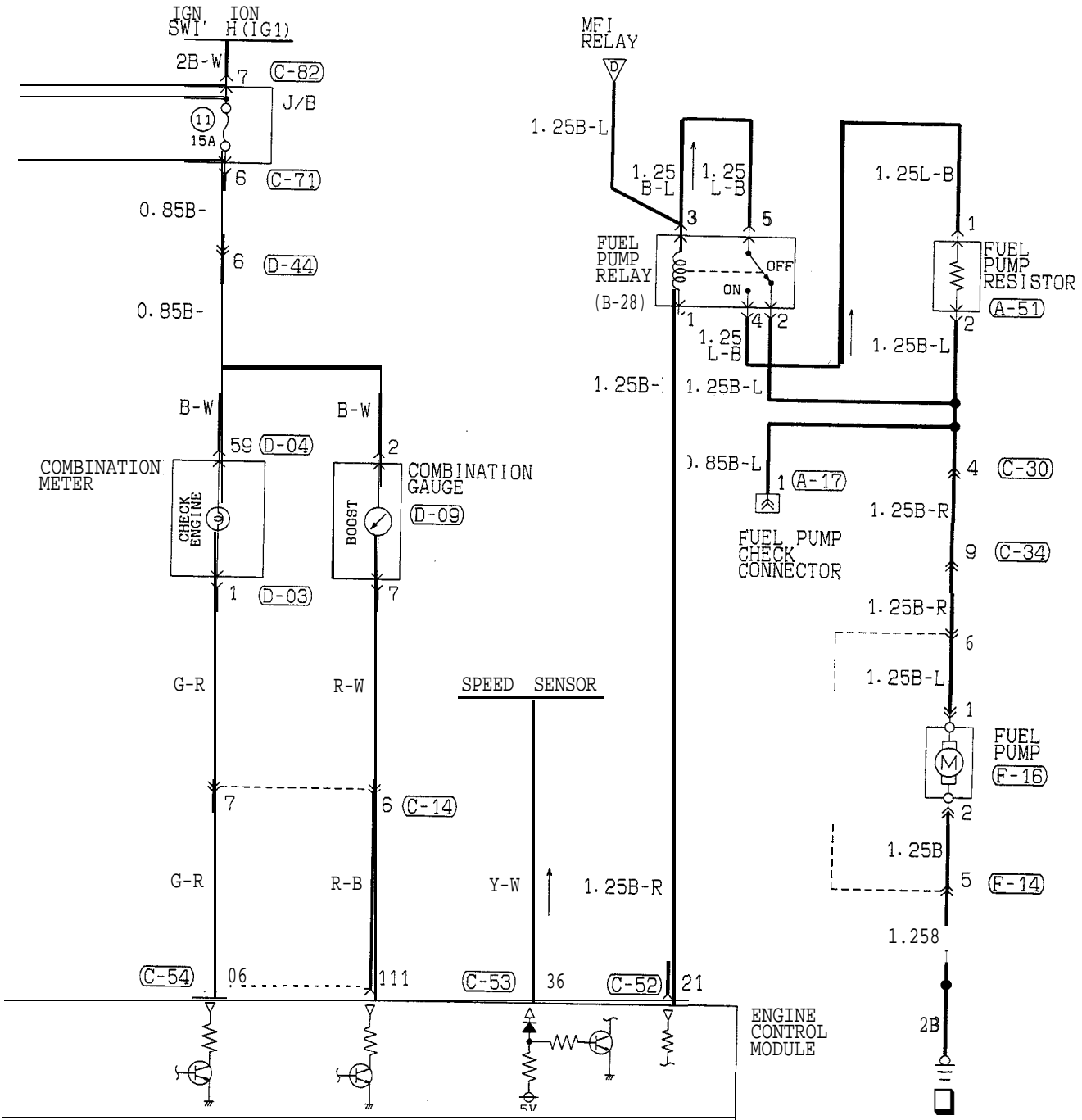

TSB Revision

MFI CIRCUIT (1992 MODEL) <TURBO> (CONTINUED)

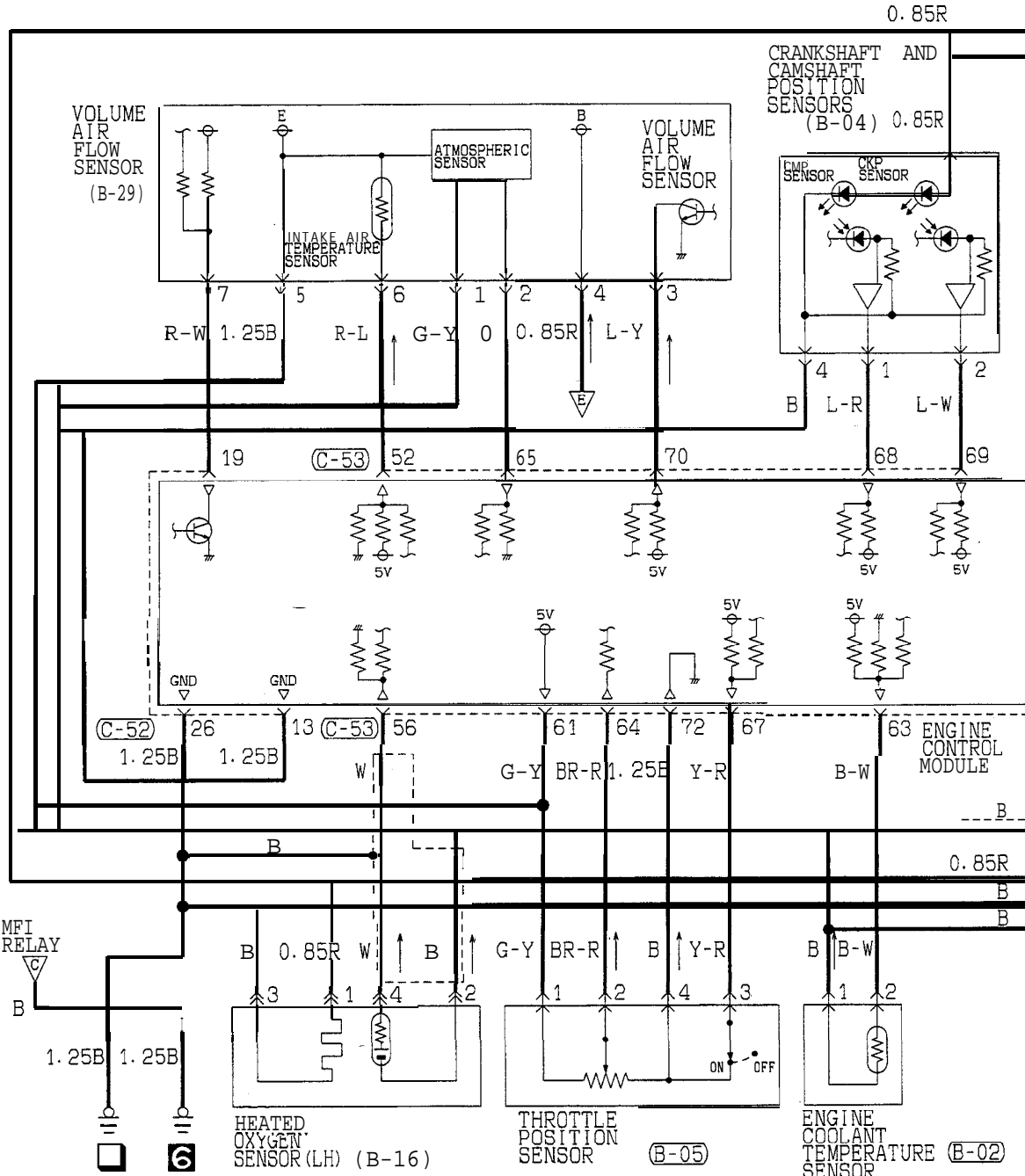

<b>(B-02)</b>	<b>(B-04)</b>	<b>(B-05)</b>	<b>(B-16)</b>	<b>(B-29)</b>	<b>(C-52)</b>	<b>(C-53)</b>
12	1234	1234	12 34	12345678	1 2 3 4 5 6 7 8 9 10 11 12 13 14 15 16 17 18 19 20 21 22 23 24 25 28	51 52 53 54 55 56 57 58 59 60 61 62 63 64 65 66 67 68 69 70 71 72

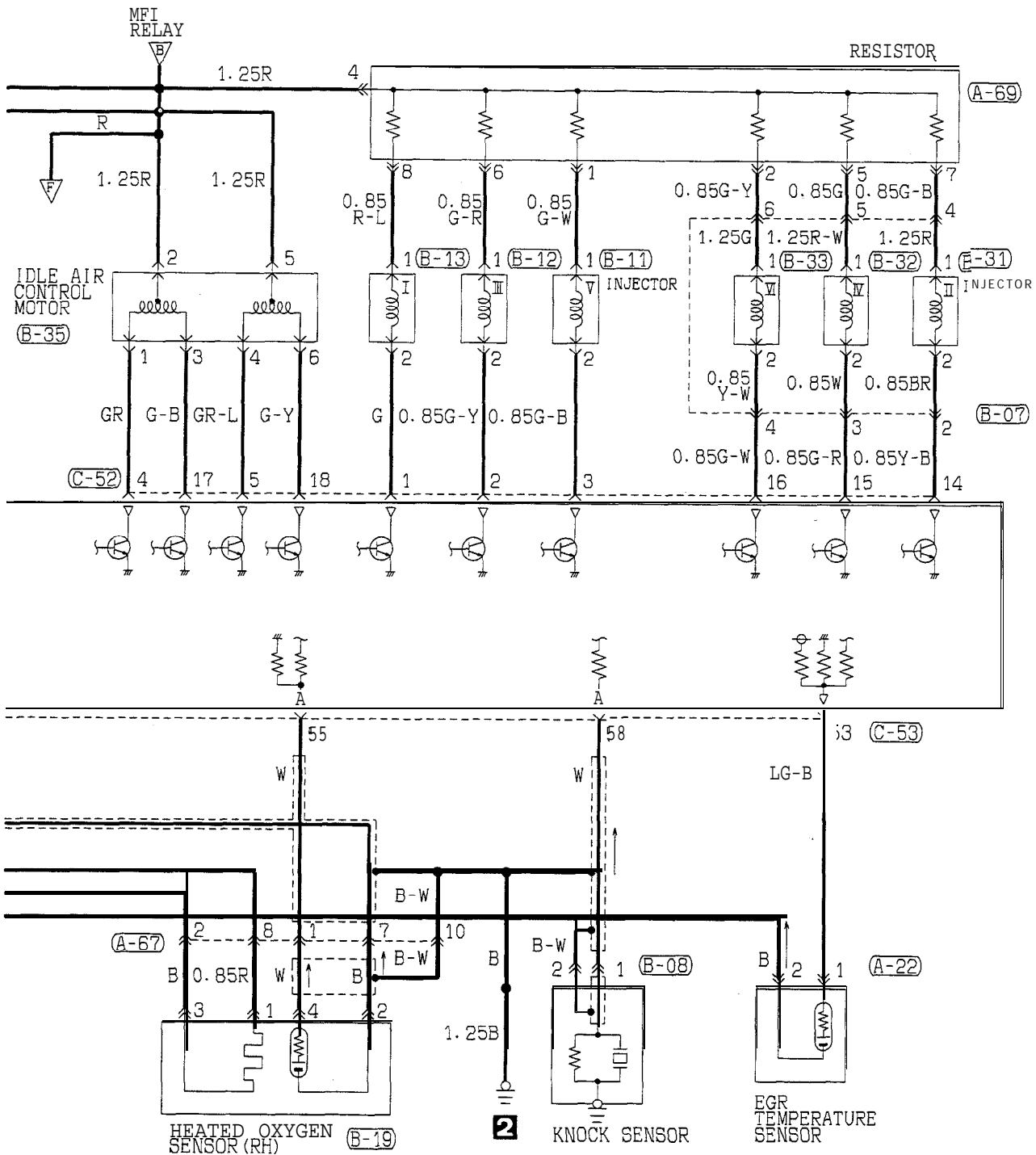

(A-22)	(A-67)	(A-69)	(B-07)	(B-08)	(B-11)	(B-12)	(B-13)	(B-19)	(B-31)	(B-32)	(B-33)	(B-35)
12	123456 7890112	1234 5678	123 456	12	12	12	12	12 34	12	12	12	123 456
(C-52)	(C-53)											
1 2 3 4 5 6 7 8 9 10 11 12 13 14 15 16 17 18 19 20 21 22 23 24 25 26	51 52 53 54 55 56 57 58 59 60 61 62 63 64 65 66 67 68 69 70 71 72											

TSB Revision

MFI CIRCUIT (1992 MODEL) <TURBO> (CONTINUED)

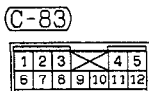
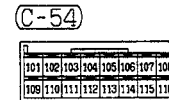
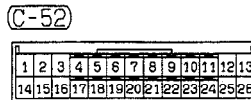
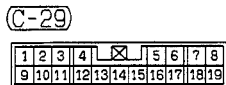
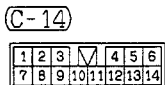
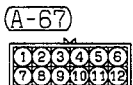
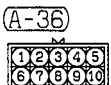
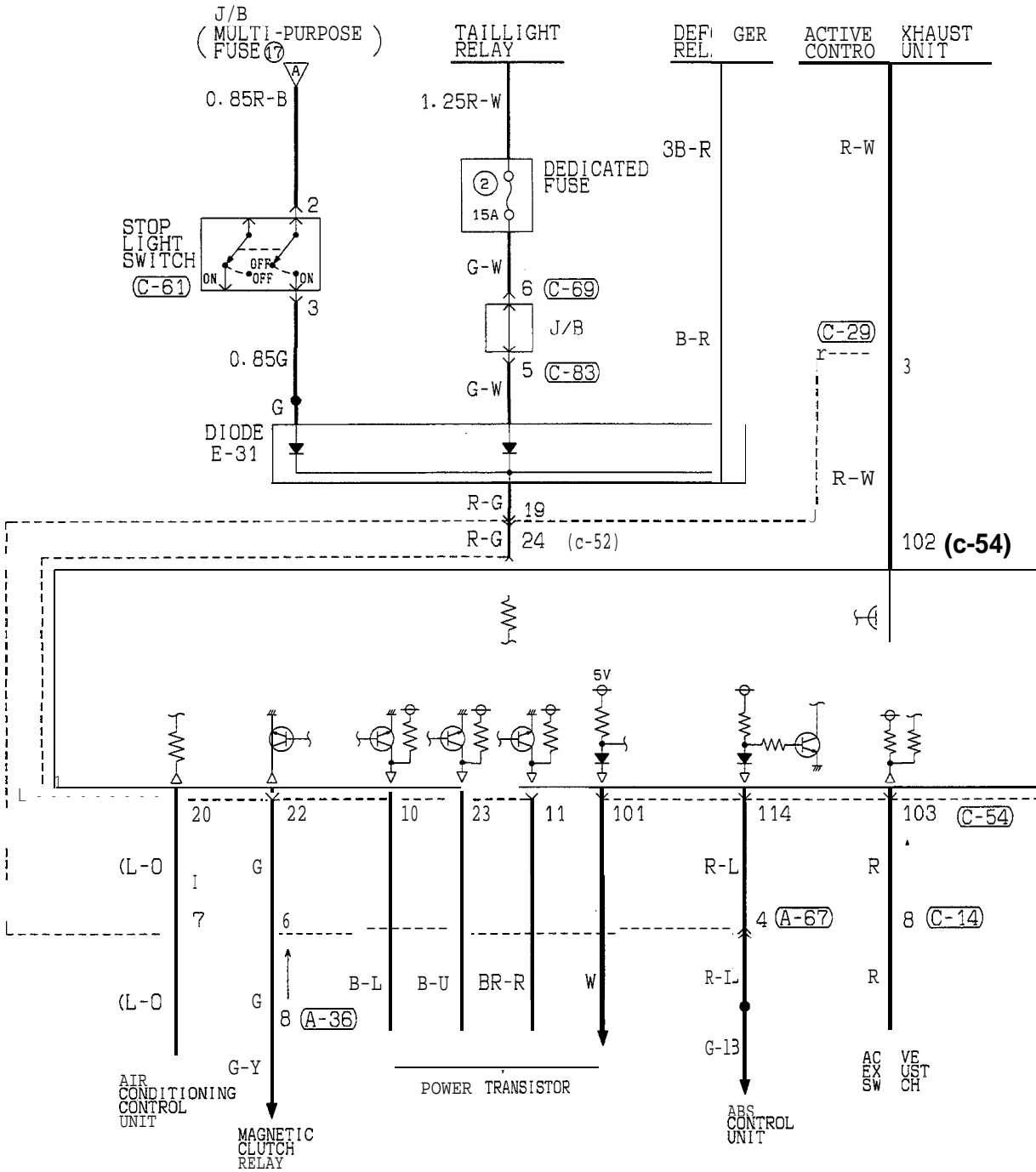

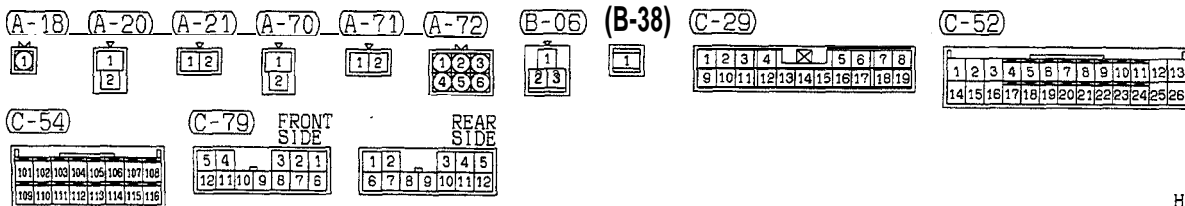
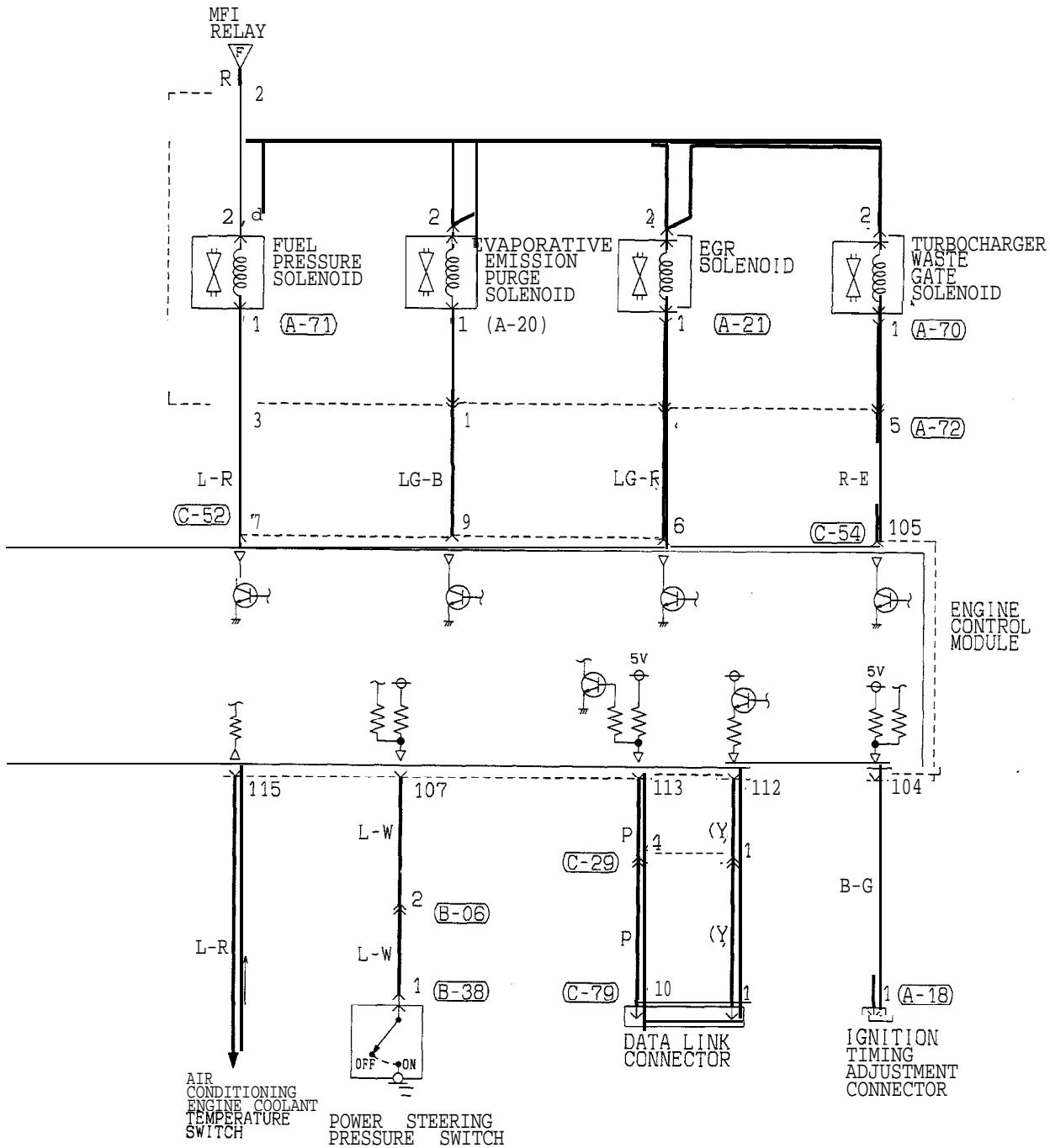

TSB Revision

# MFI CIRCUIT (1993 MODELS)

<NON TURBO>

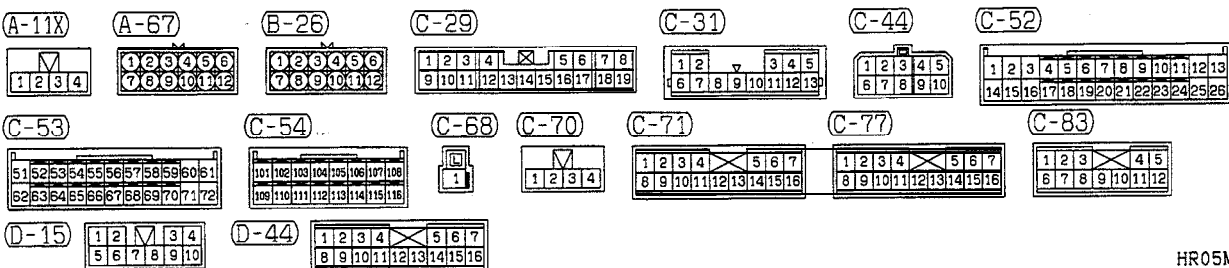
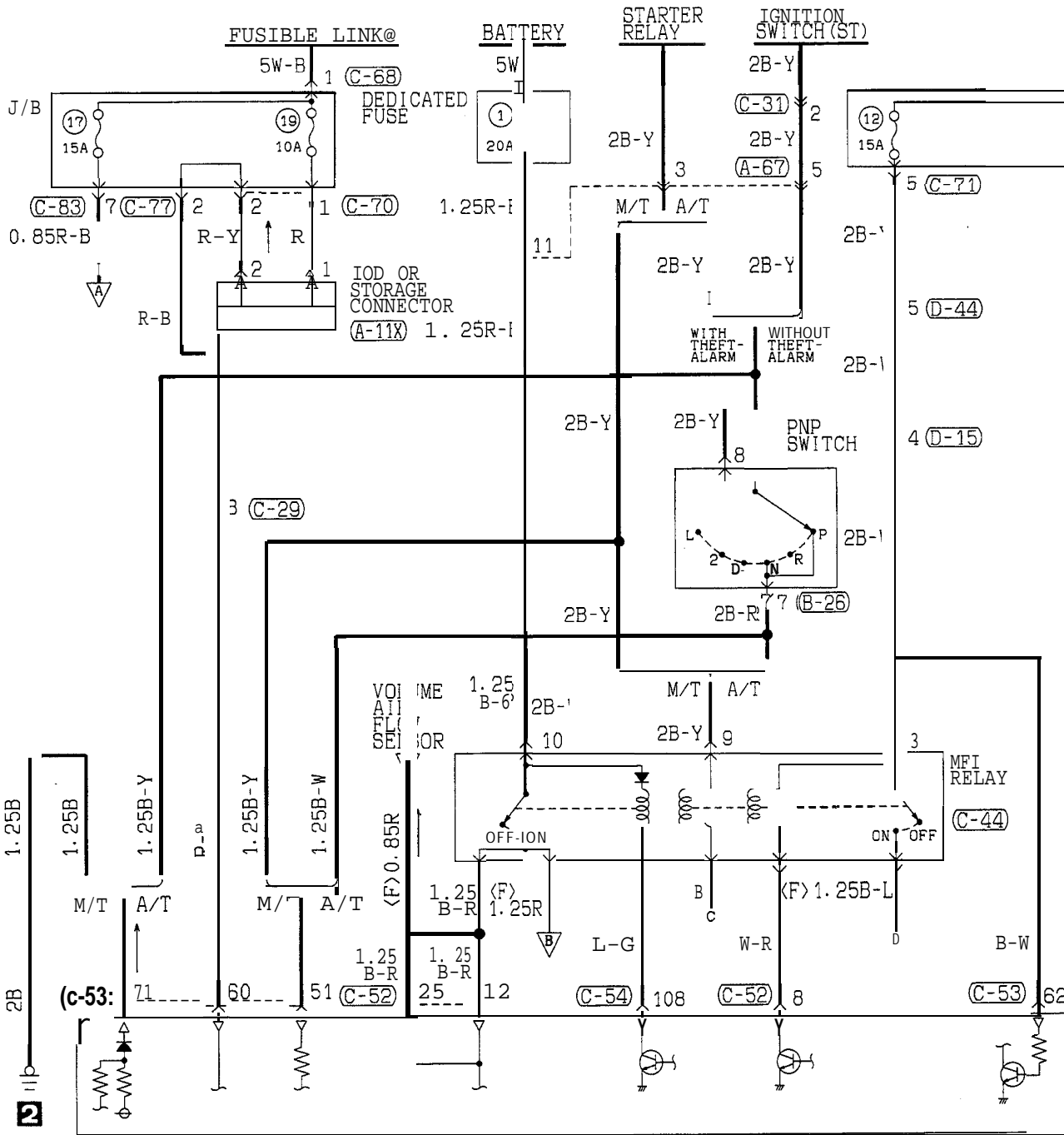

HR05M01AA

TSB Revision

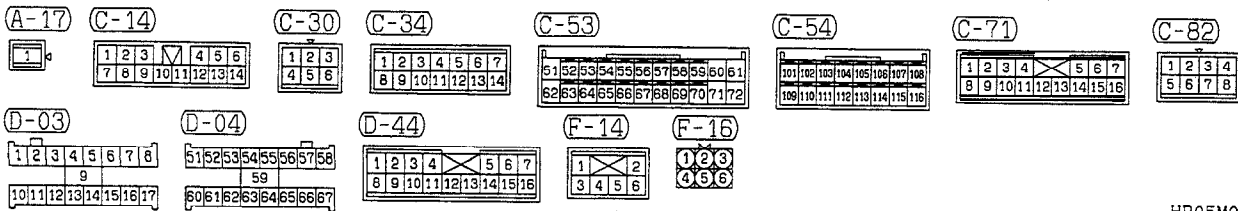
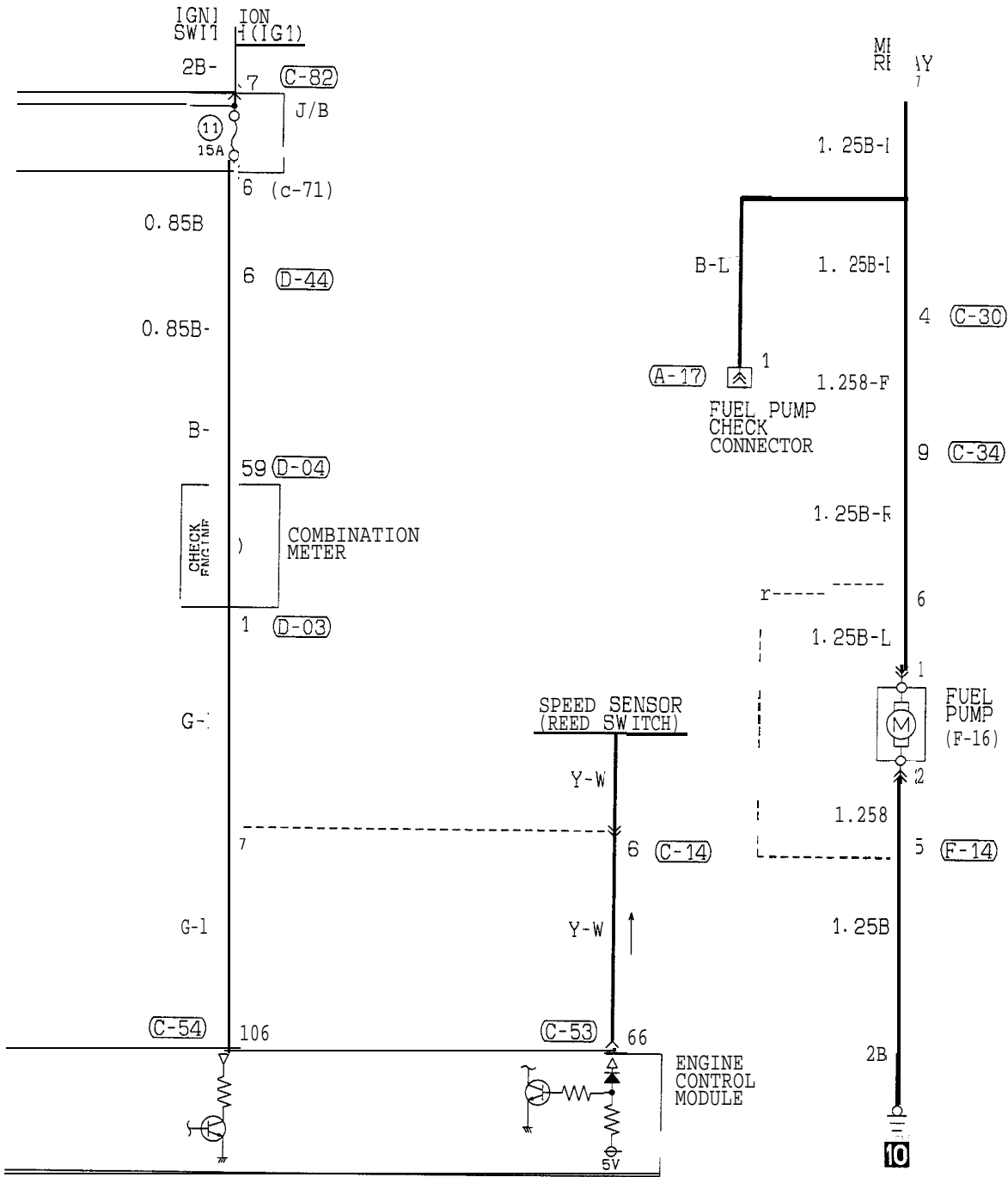

TSB Revision



MFI CIRCUIT (1993 MODELS) <NON TURBO> (CONTINUED)

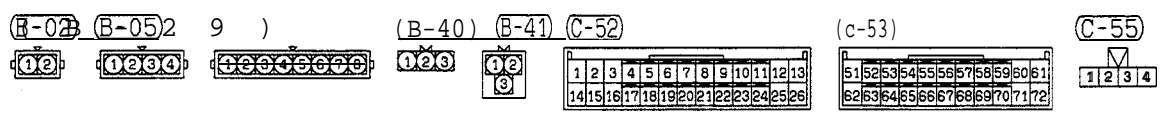
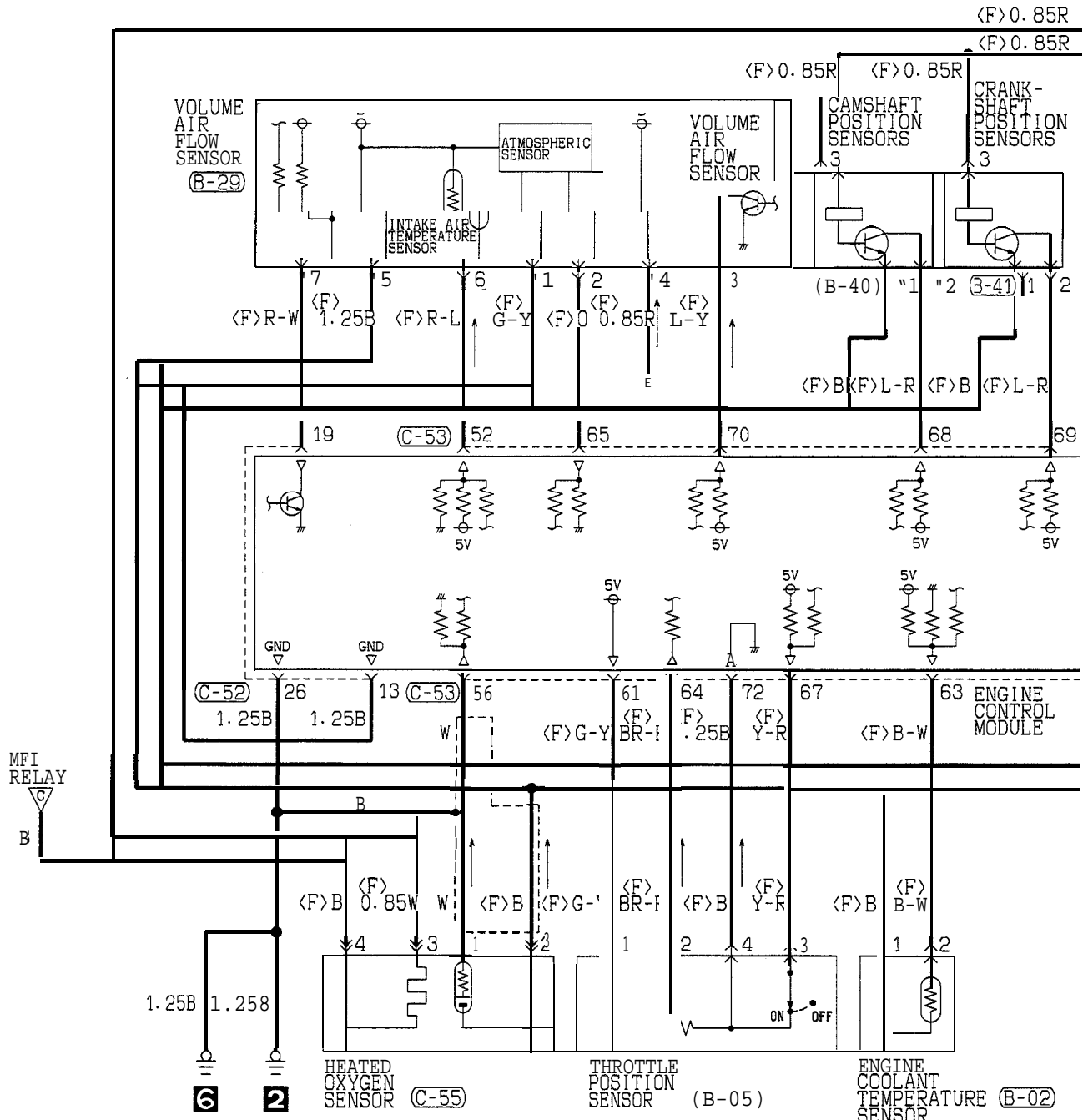

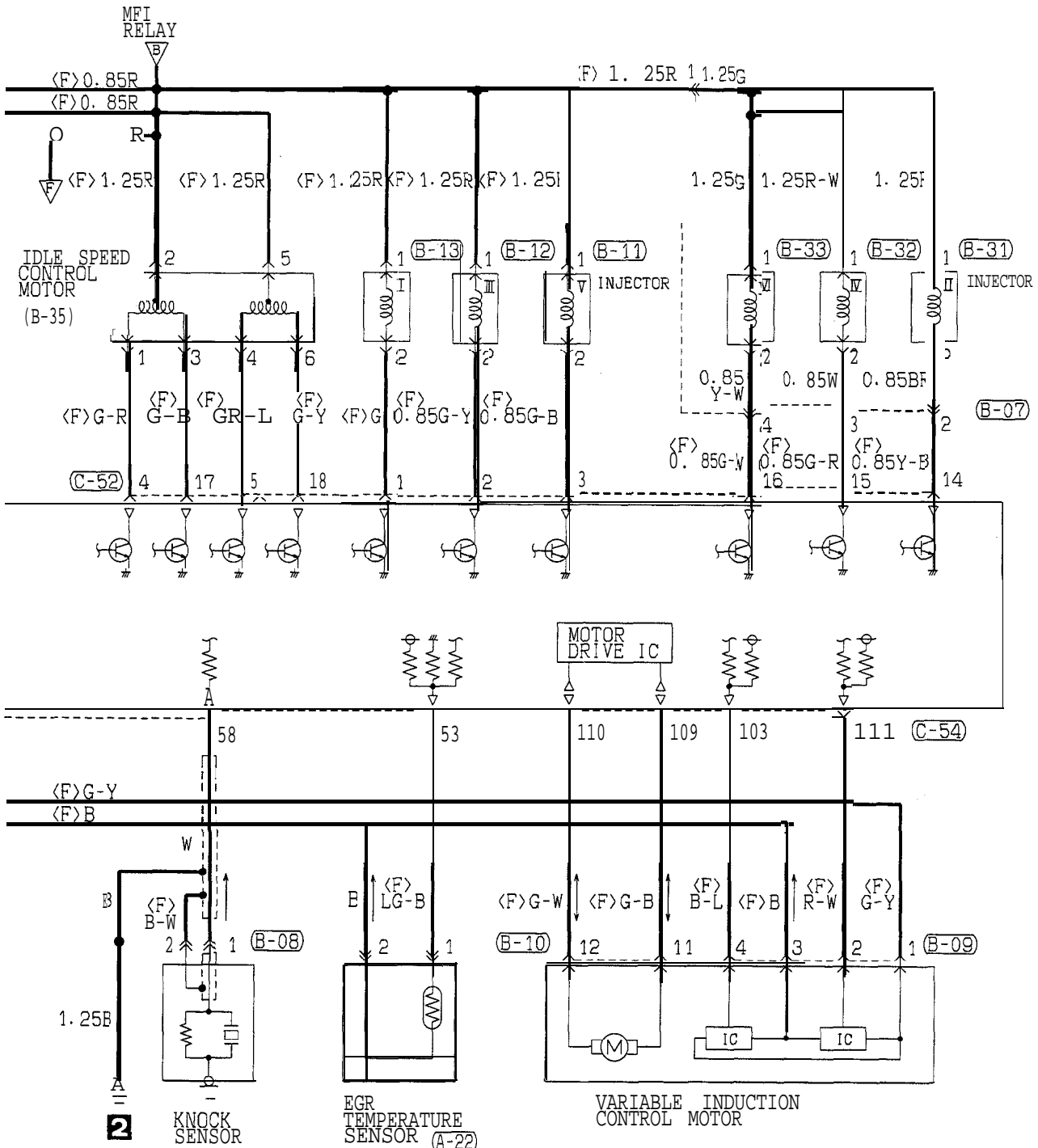

- (A-22) (B-07) **(B-08)** (B-09) 1 (B-12) (B-13) (B-31) (B-32) (B-33) (B-35)
- |   |   |
|---|---|
| 1 | 2 |
| 3 | 4 |

1	2	3
4	5	6

1	2	3	4
5	6	7	8

1	2
---	---

1	2
---	---

1	2
---	---

1	2
---	---

1	2
---	---

1	2	3
4	5	6



MFI CIRCUIT (1993 MODELS) <NON TURBO> (CONTINUED)

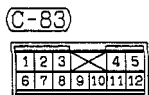
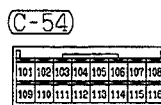
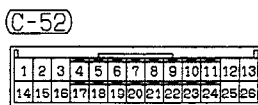
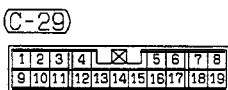
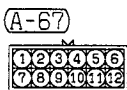
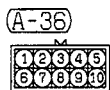
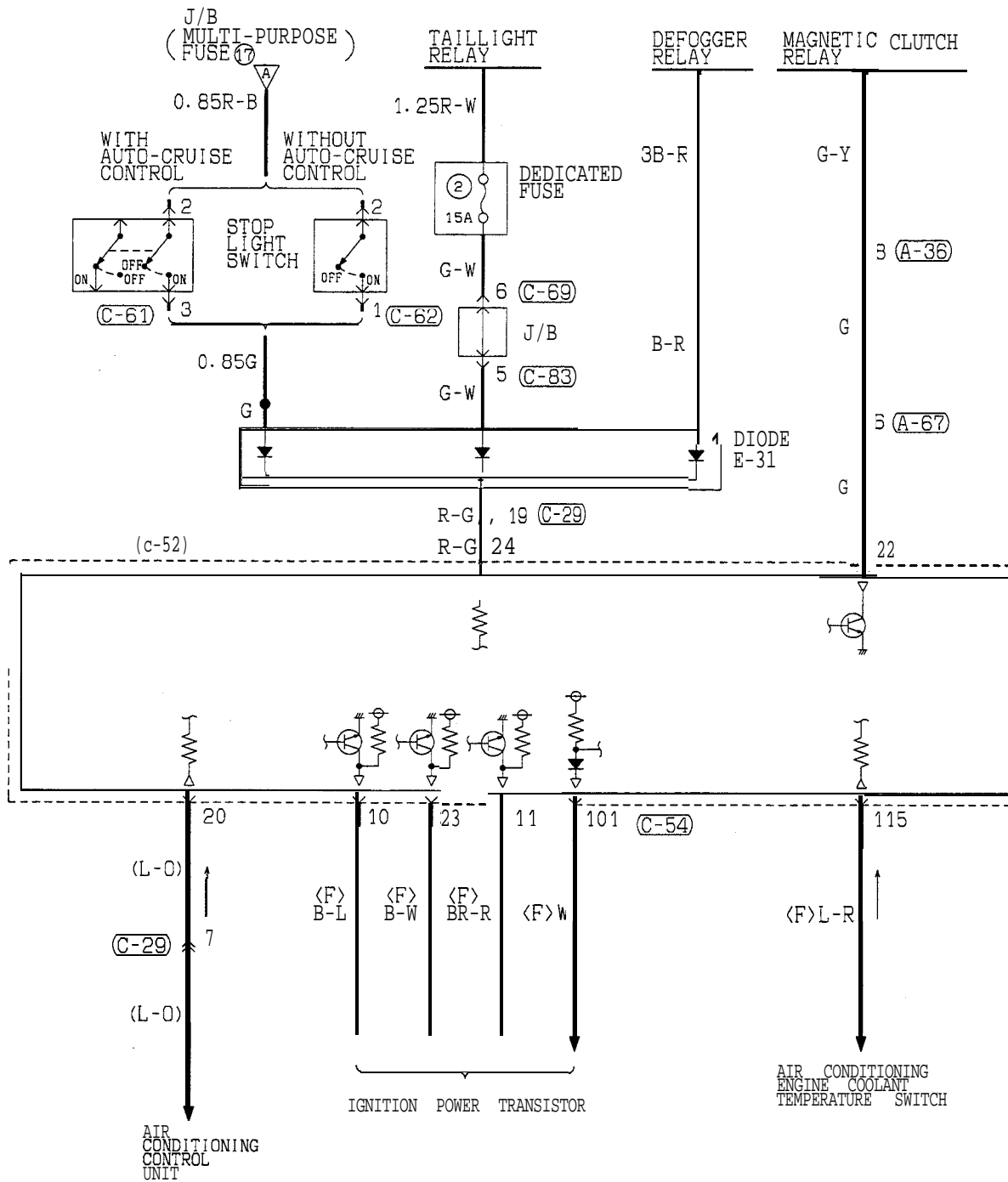

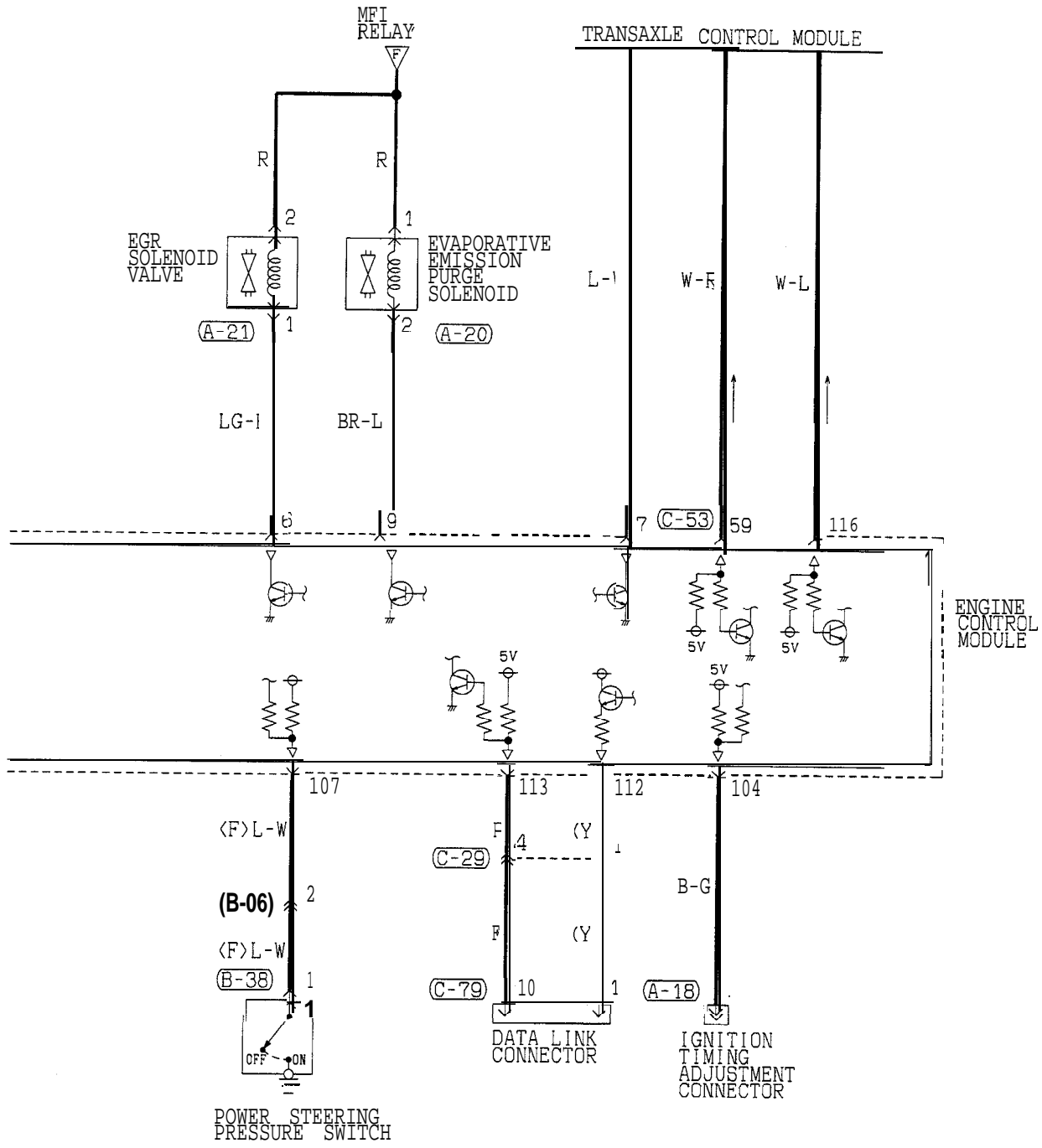

(A-18)	(A-20)	(A-21)	(B-06)	(B-38)	(C-29)	(C-53)	(C-79) FRONT SIDE	REAR SIDE
1	1	1	1	1	1 2 3 4 5 6 7 8 9 10 11 12 13 14 15 16 17 18 19	5 6 7 8 9 10 11 12 13 14 15 16 17 18 19 20 21 22 23 24 25 26 27 28 29 30 31 32	5 4 3 2 1 12 11 10 9 8 7 6	1 2 3 4 5 6 7 8 9 10 11 12

TSB Revision

# MFI CIRCUIT (1993 MODELS)

<TURBO>

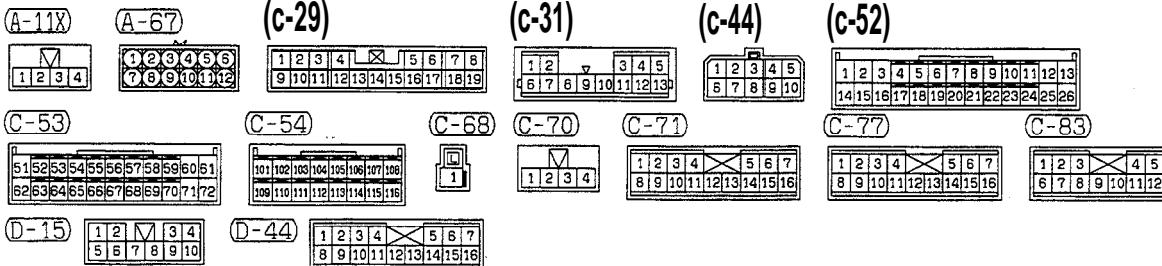
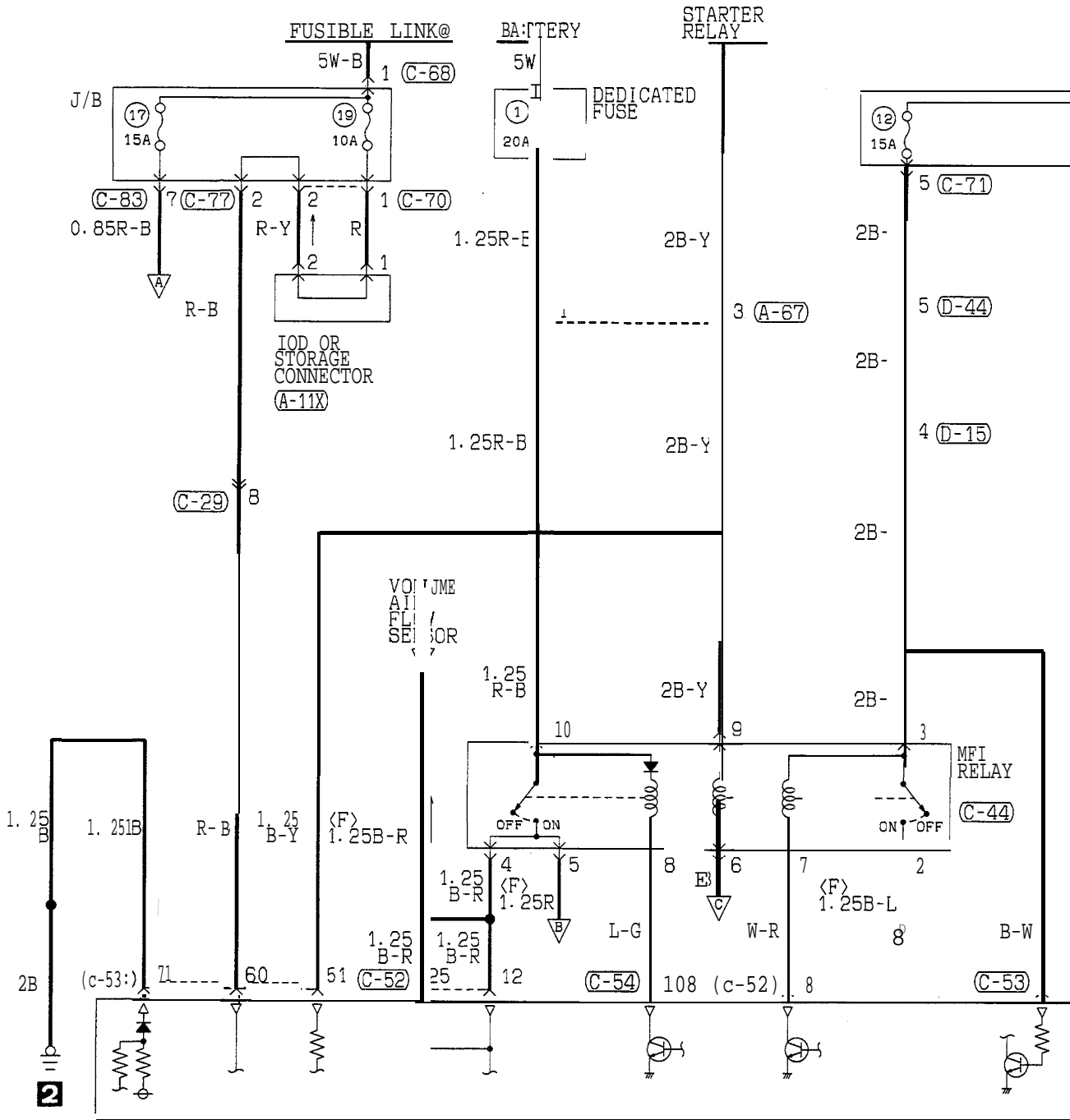

HR05M06AA

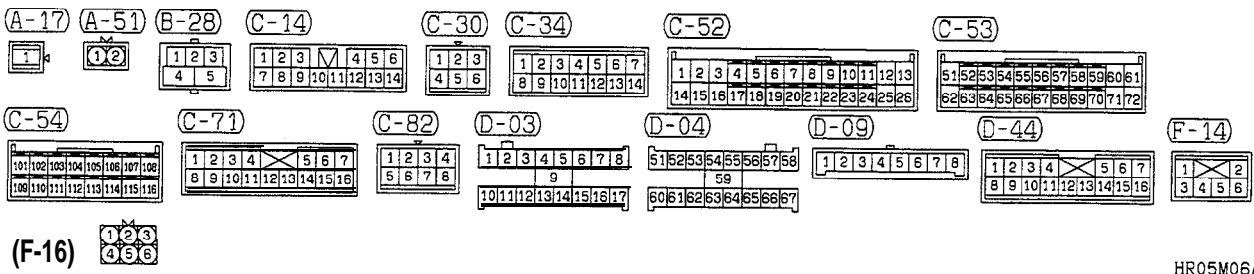
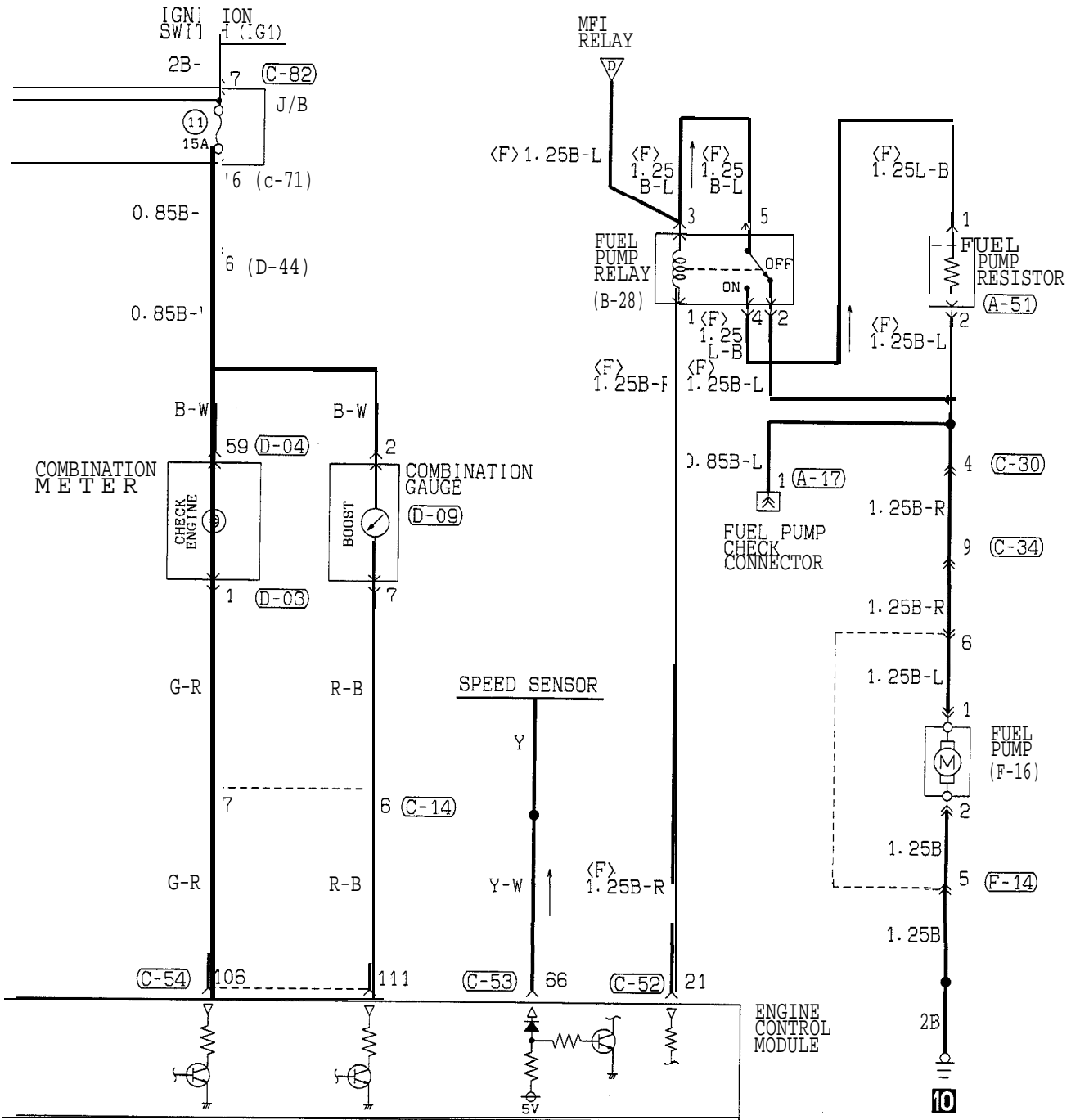

TSB Revision

MFI CIRCUIT (1993 MODELS) <TURBO> (CONTINUED)

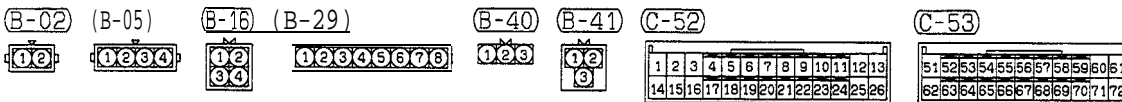
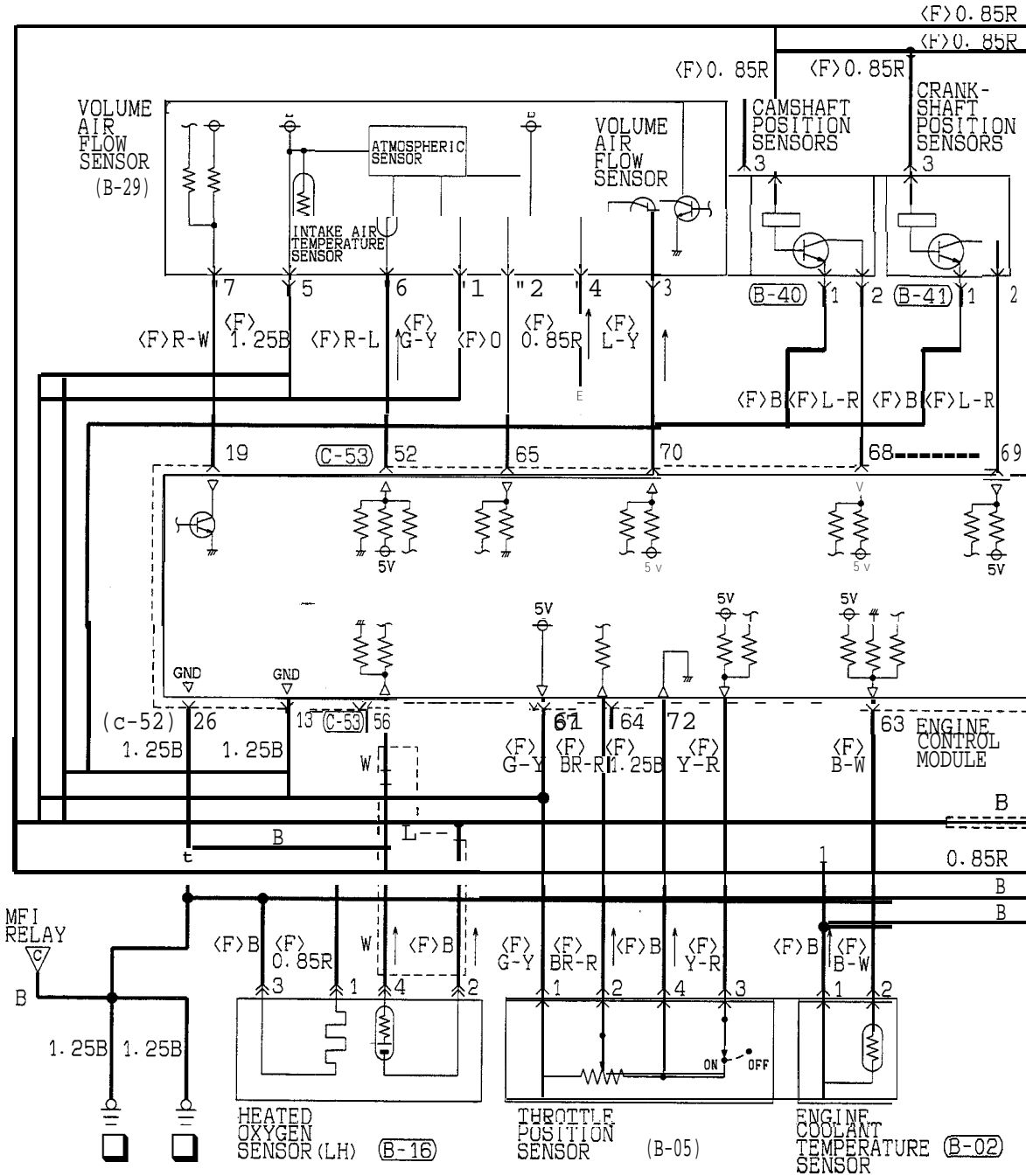

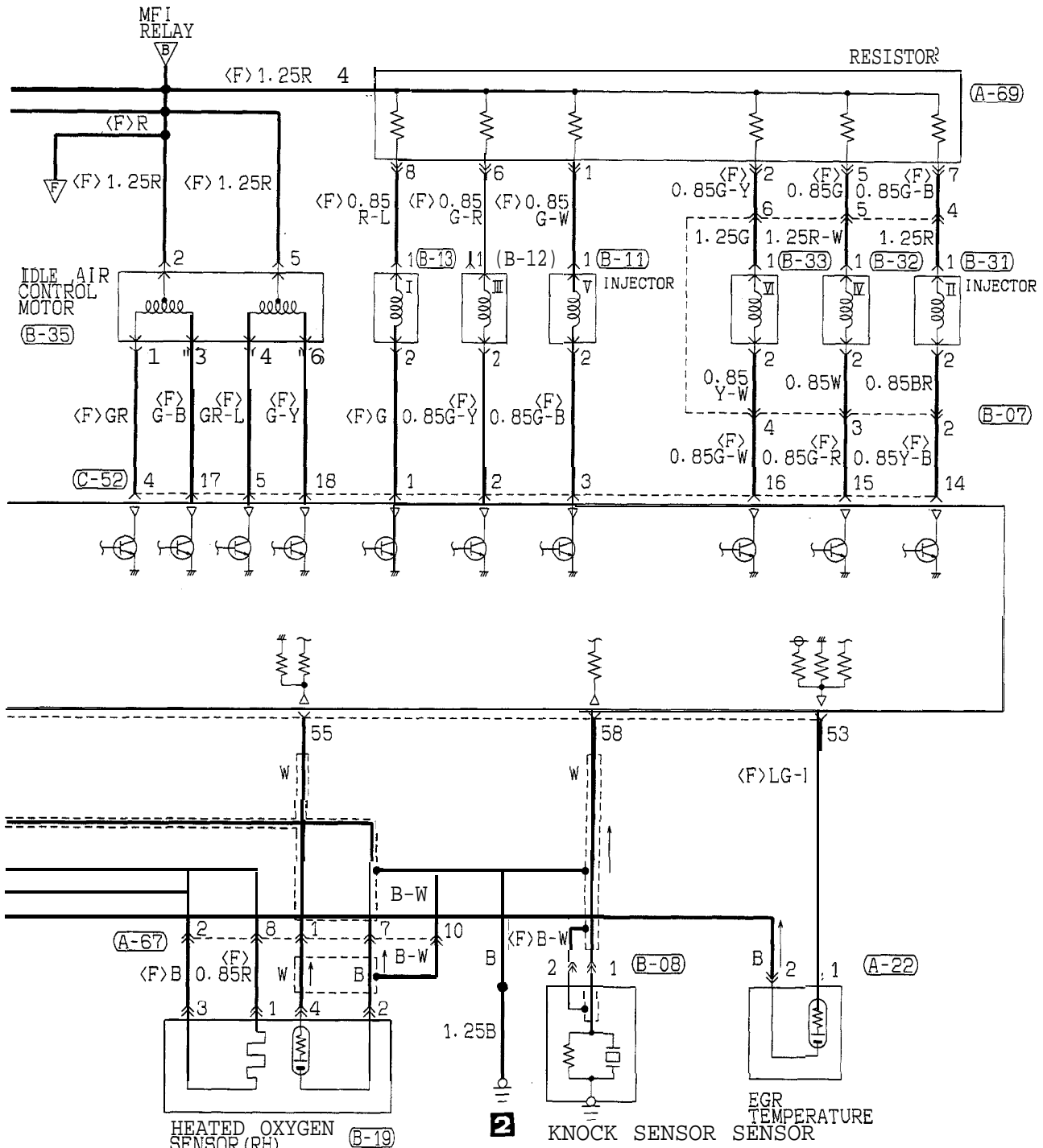

- A-22
- A-67
- A-69
- B-07
- B-08
- B-11
- B-12
- B-13
- B-19
- B-31
- B-32
- B-33
- B-35

C-52

1	2	3	4	5	6	7	8	9	10	11	12	13
14	15	16	17	18	19	20	21	22	23	24	25	26



MFI CIRCUIT (1993 MODELS) <TURBO> (CONTINUED)

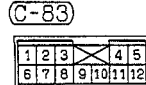
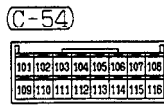
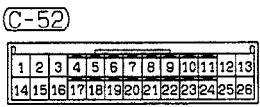
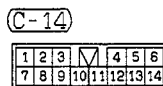
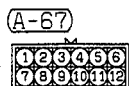
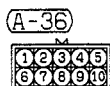
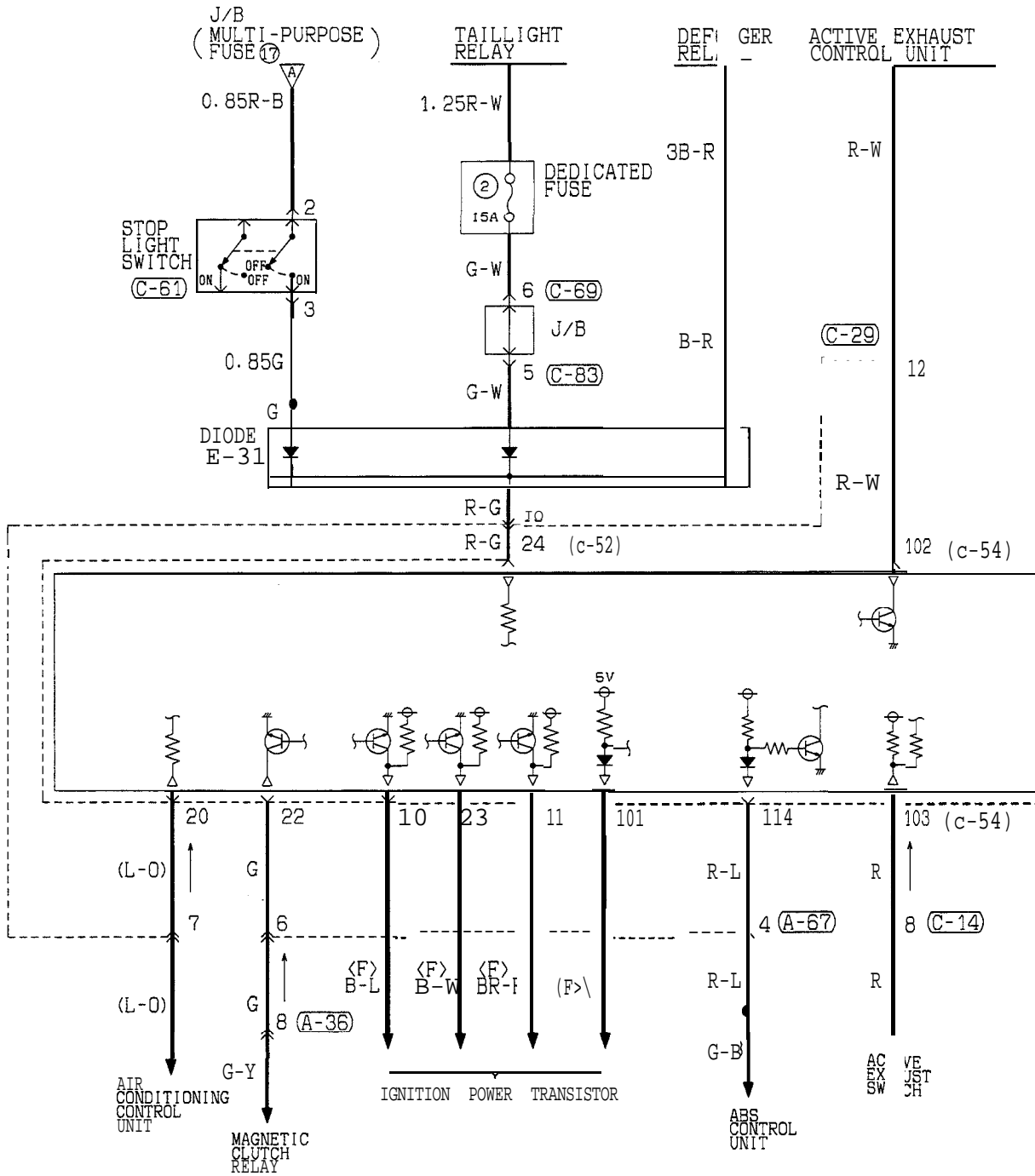

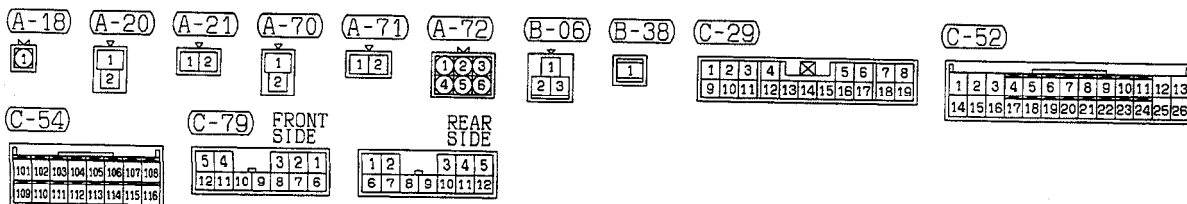
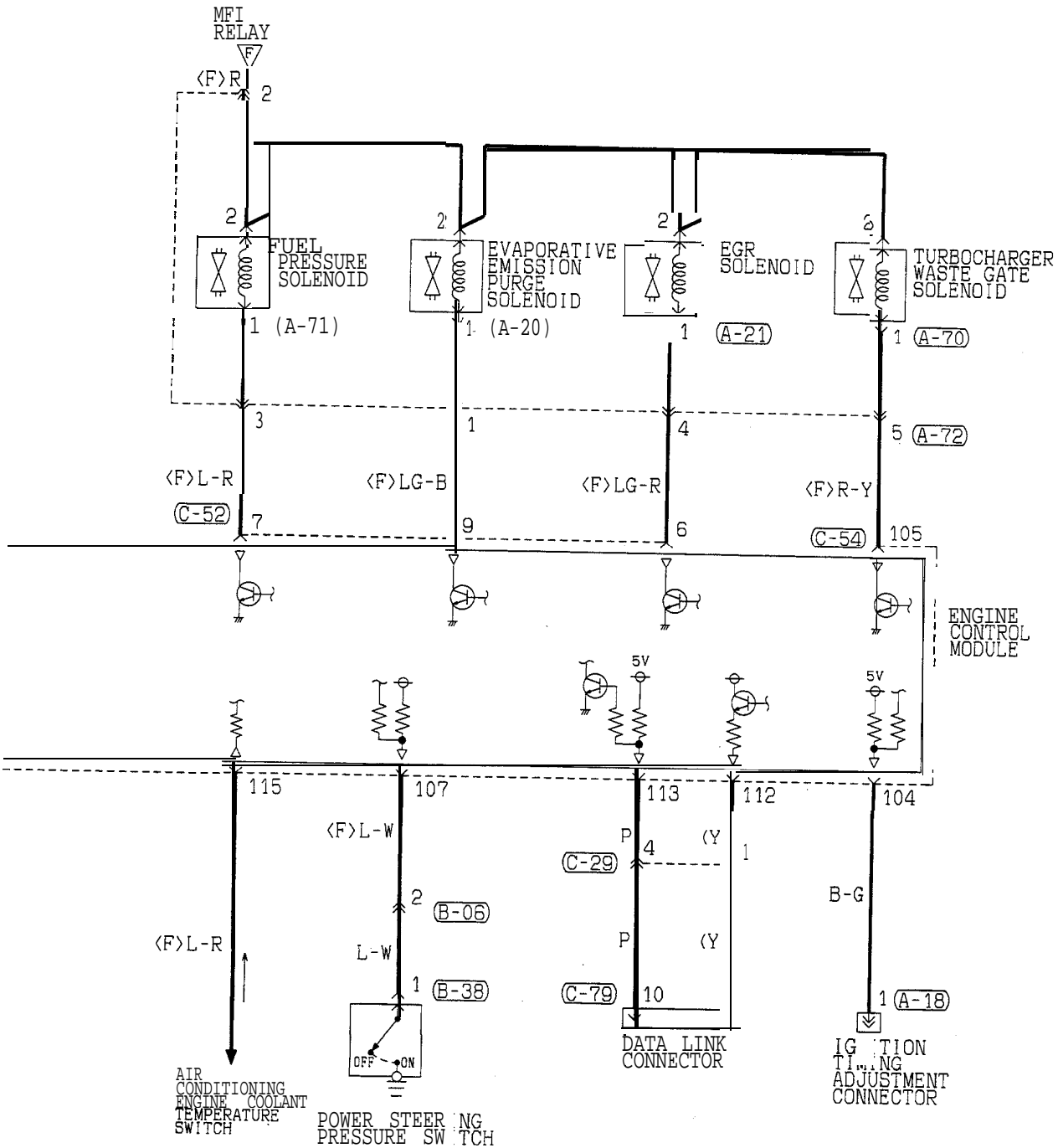

TSB Revision

# MFI CIRCUIT (1994 MODELS)

<NON TURBO>

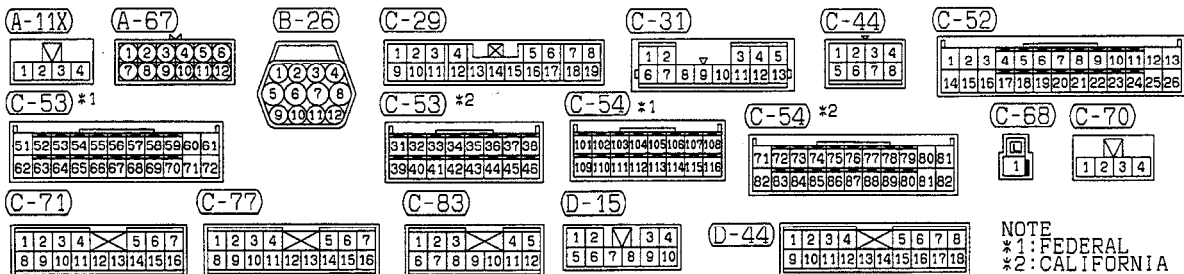
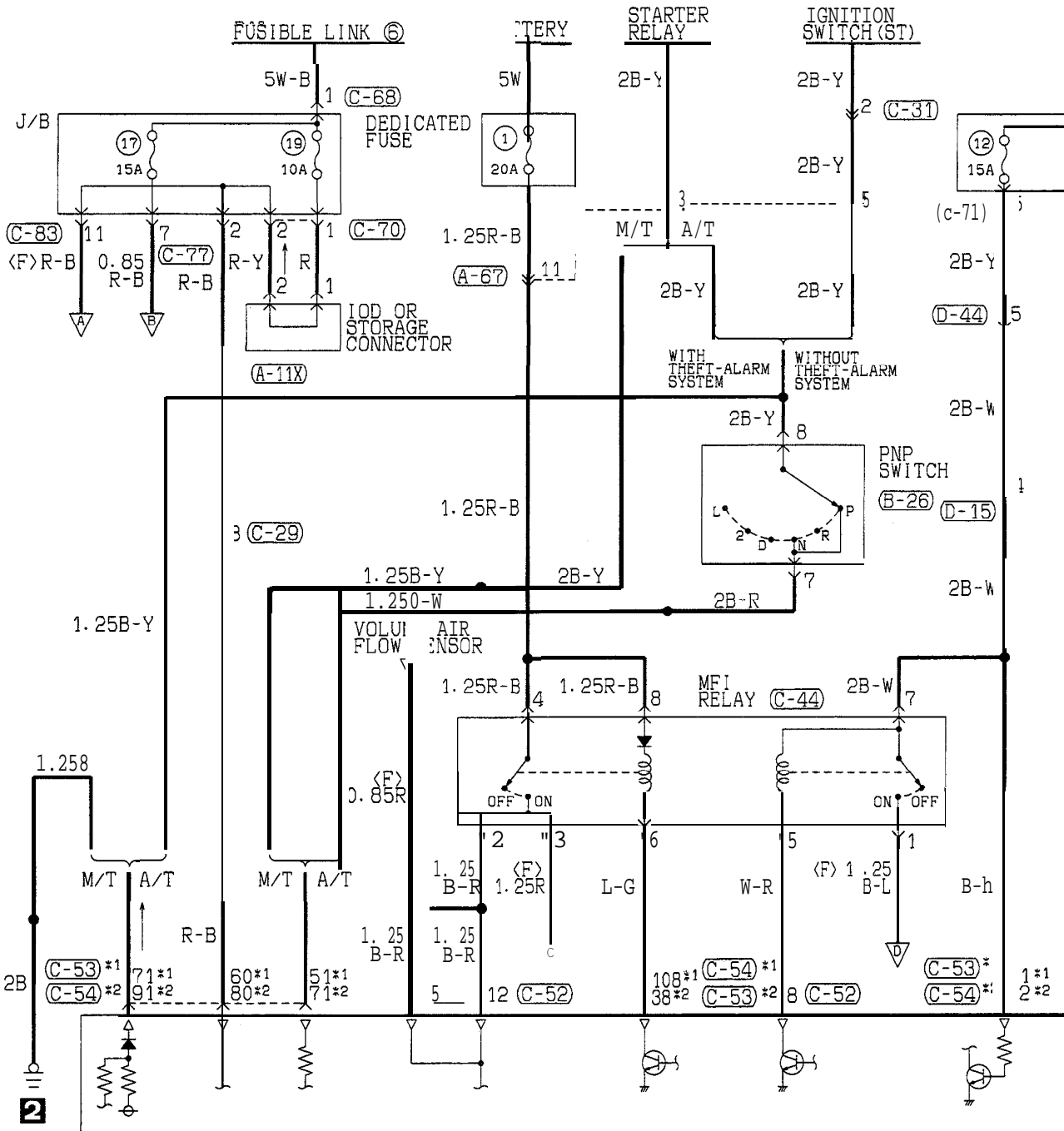

NOTE  
 \*1: FEDERAL  
 \*2: CALIFORNIA HR05M02AA

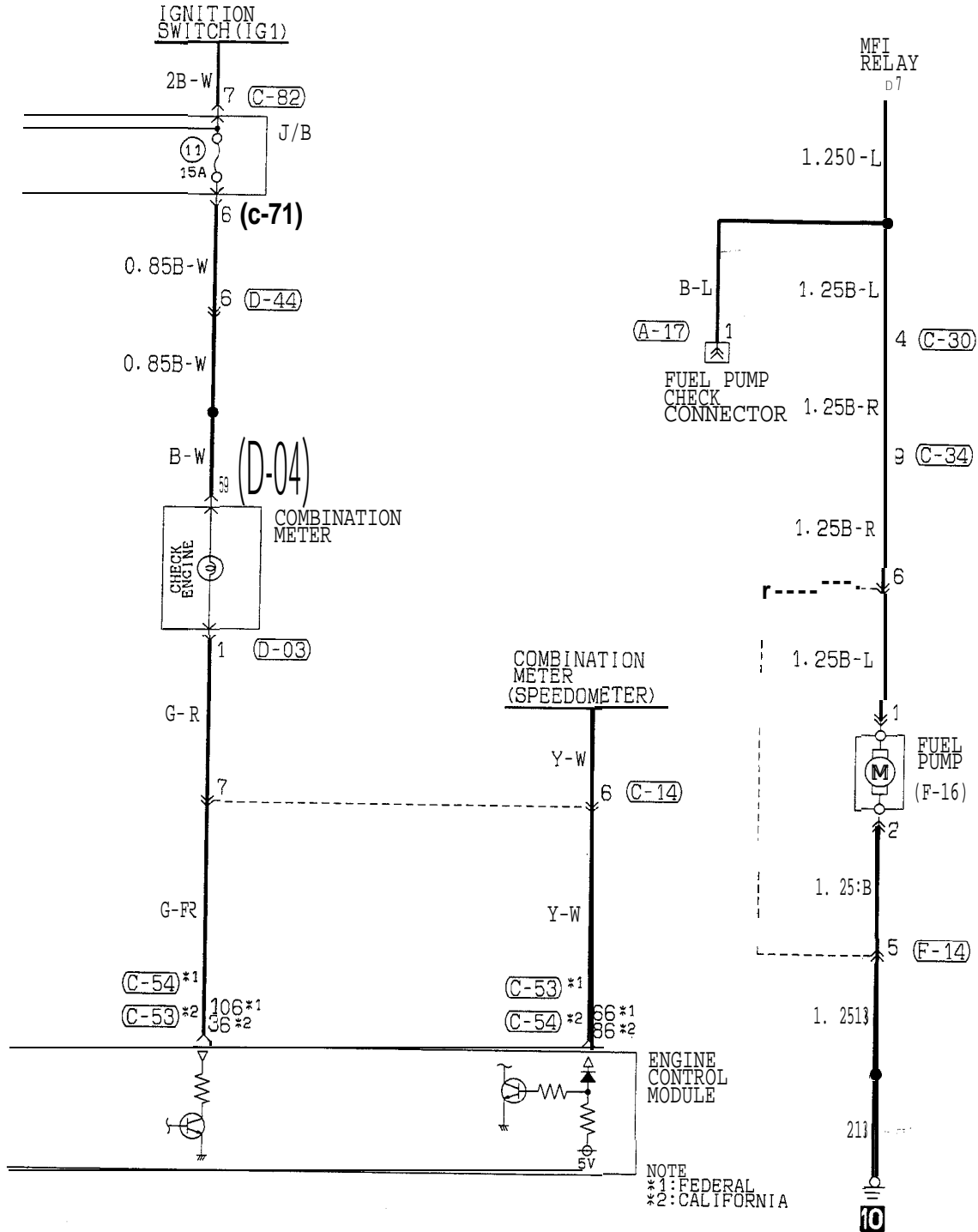

NOTE  
 \*1: FEDERAL  
 \*2: CALIFORNIA

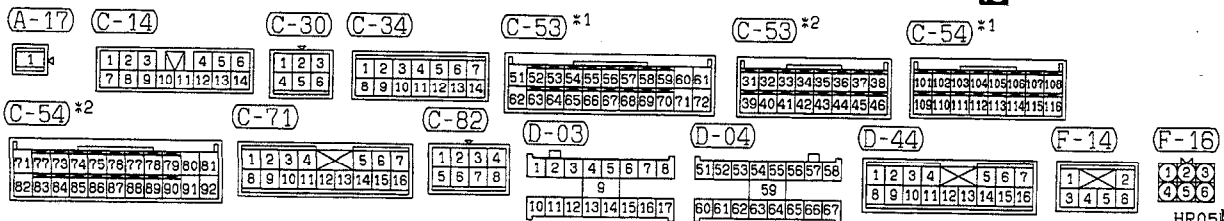

HR05M02AB

TSB Revision

MFI CIRCUIT (1994 MODELS) <NON TURBO> (CONTINUED)

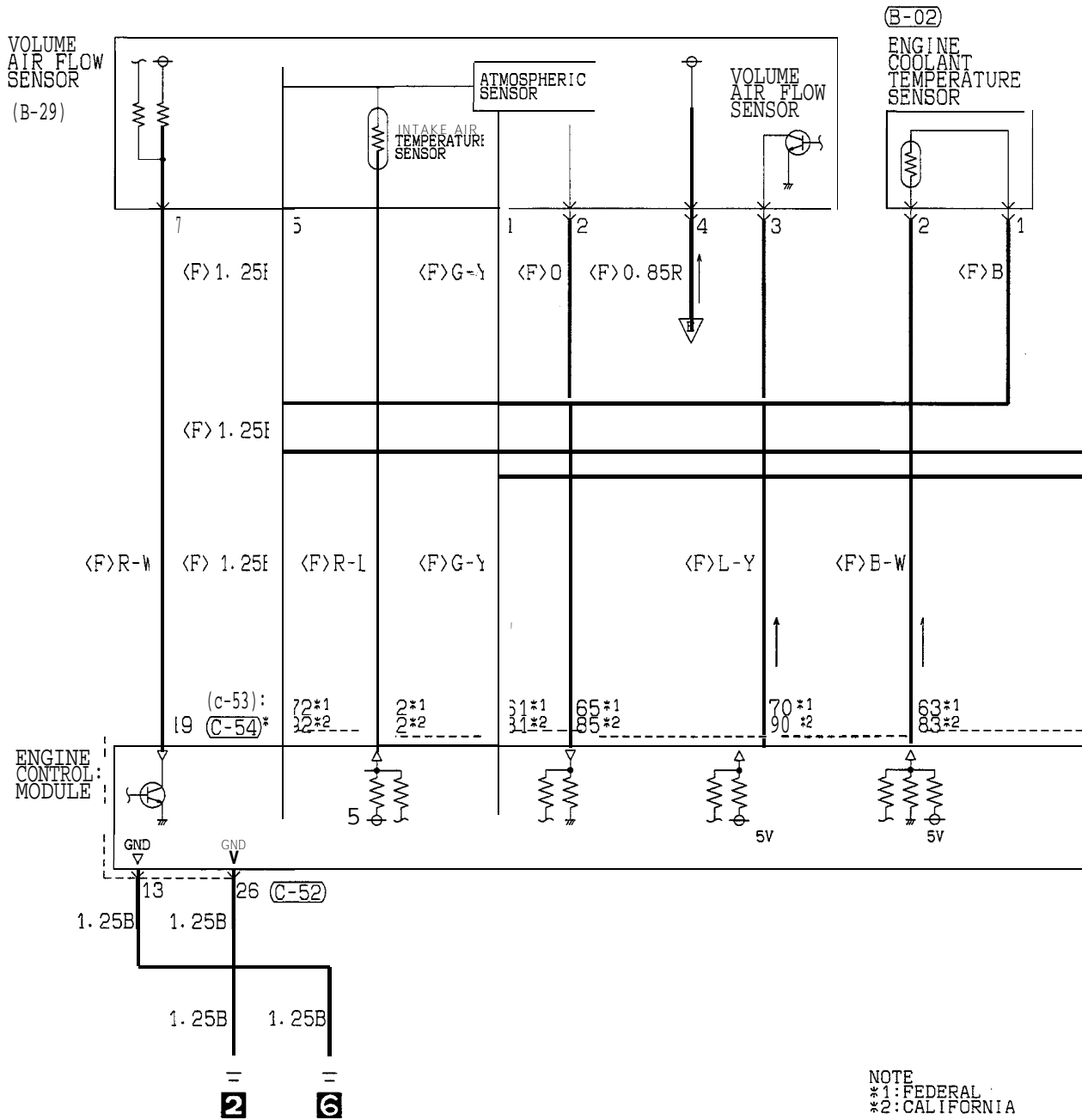

(B-02)

(B-29)

(C-52)

(C-53)\*1

(C-54)\*2



1	2	3	4	5	6	7	8	9	10	11	12	13
14	15	16	17	18	19	20	21	22	23	24	25	26

51	52	53	54	55	56	57	58	59	60	61
62	63	64	65	66	67	68	69	70	71	72

71	72	73	74	75	76	77	78	79	80	81
82	83	84	85	86	87	88	89	90	91	92

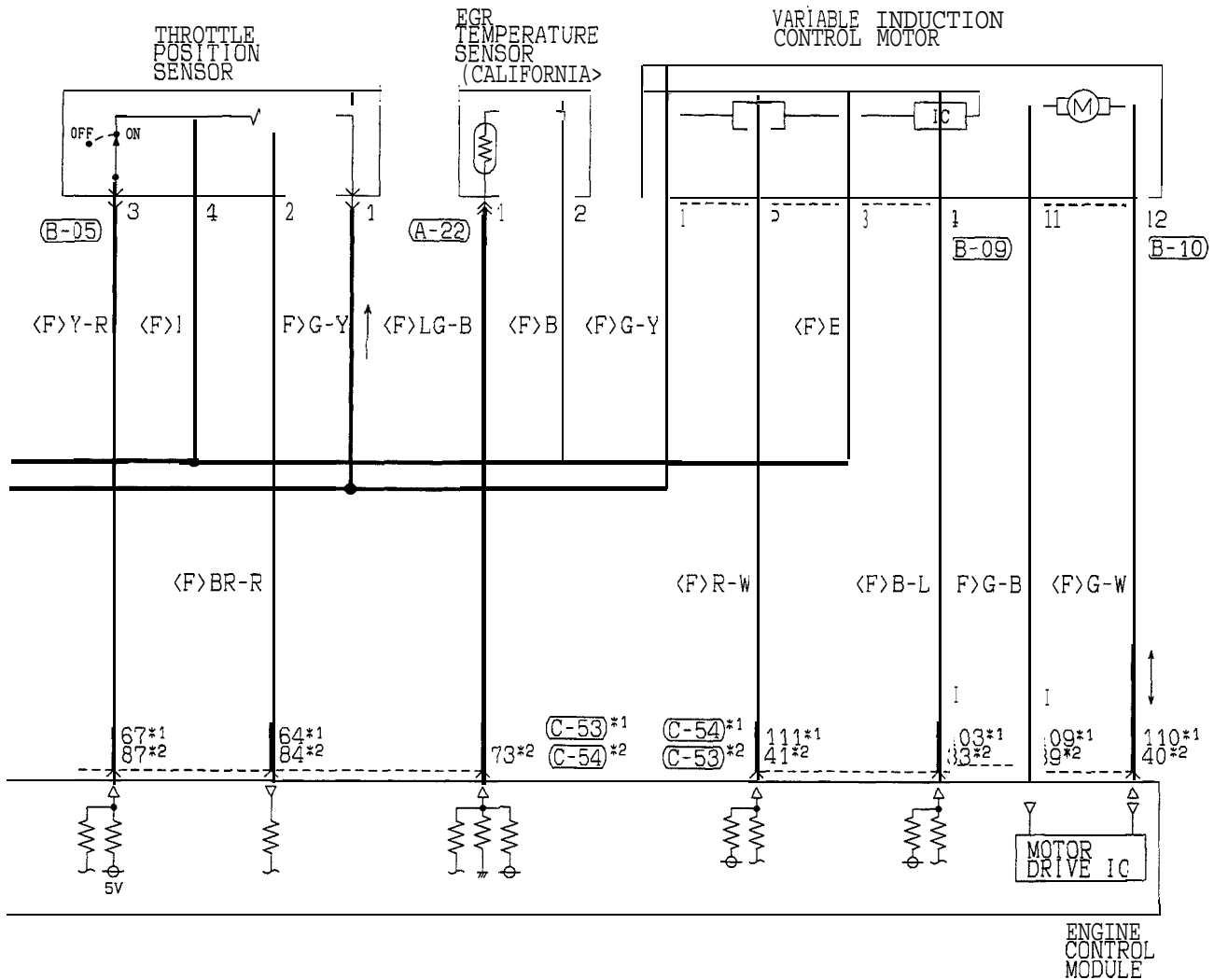

NOTE  
 \*1: FEDERAL  
 \*2: CALIFORNIA

A-22	B-05
02	1234

B-09
1234

B-10
02

C-53*1
51 52 53 54 55 56 57 58 59 60 61
62 63 64 65 66 67 68 69 70 71 72

C-53*2
31 32 33 34 35 36 37 38
39 40 41 42 43 44 45 46

C-54*1
101 102 103 104 105 106 107 108
109 110 111 112 113 114 115 116

C-54*2
71 72 73 74 75 76 77 78 79 80 81
82 83 84 85 86 87 88 89 90 91 92

HR05M02BB

TSB Revision

MFI CIRCUIT (1994 MODELS) <NON TURBO> (CONTINUED)

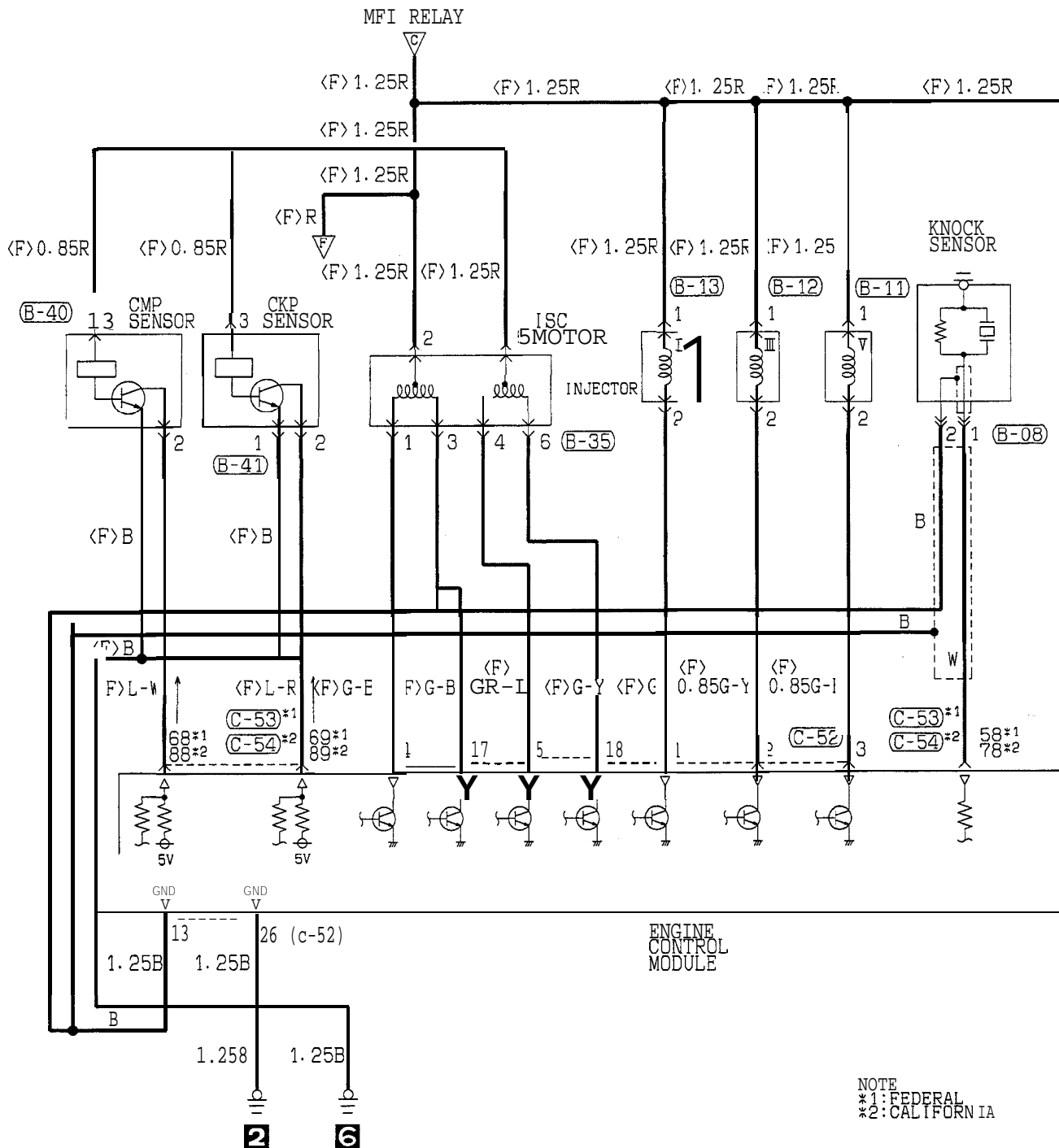

B-08

B-11

B-12

B-13

B-35

B-40

B-41

C-52

C-53 \*1

C-54 \*2

1	2	3	4	5	6	7	8	9	10	11	12	13
14	15	16	17	18	19	20	21	22	23	24	25	26

51	52	53	54	55	56	57	58	59	60	61
62	63	64	65	66	67	68	69	70	71	72

71	72	73	74	75	76	77	78	79	80	81
82	83	84	85	86	87	88	89	90	91	92

TSB Revision

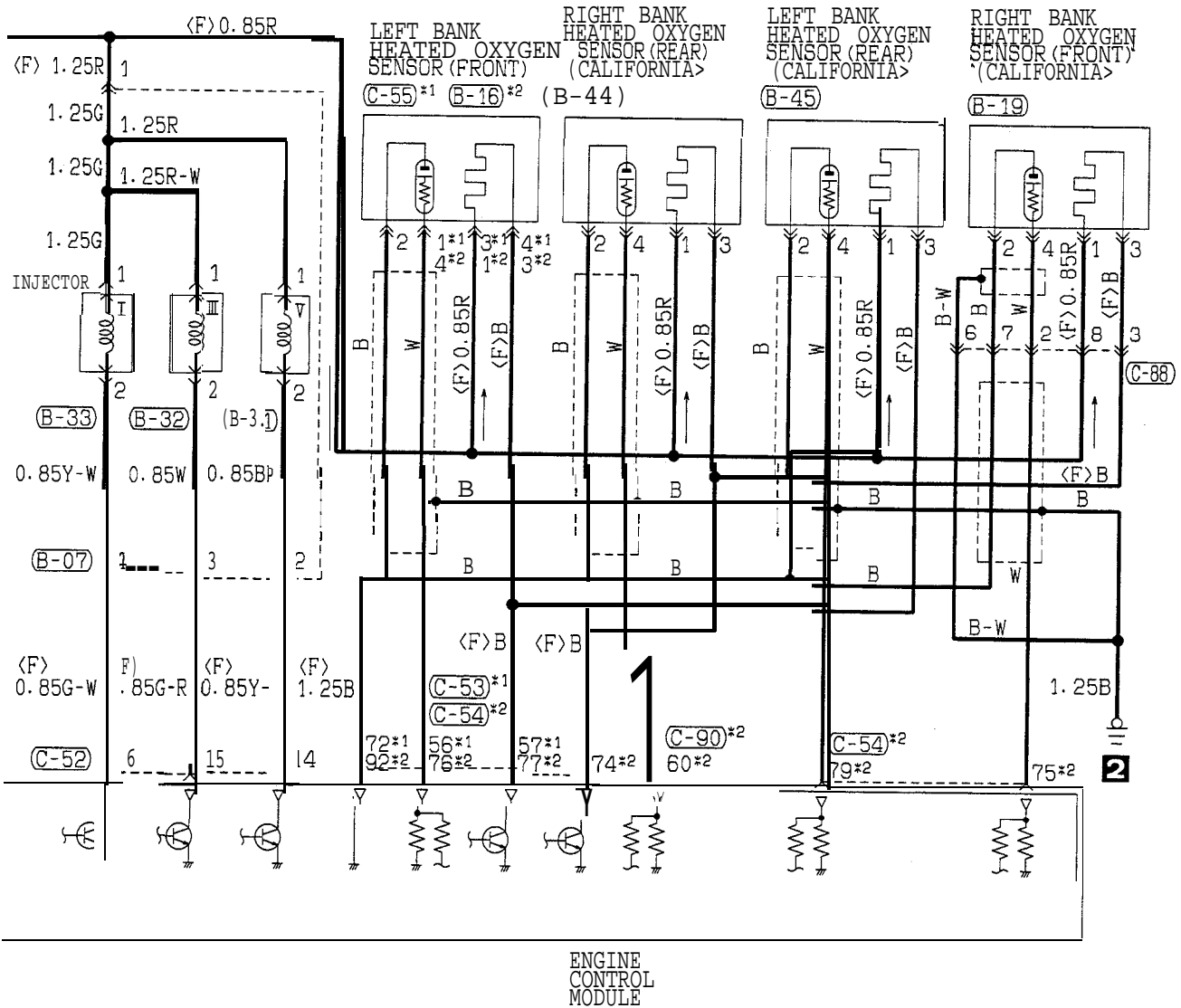

NOTE  
 \*1: FEDERAL  
 \*2: CALIFORNIA

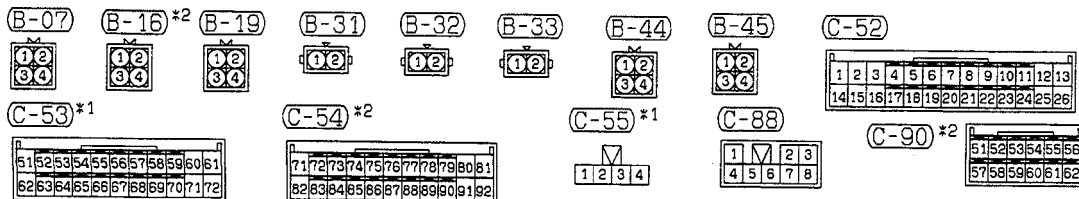

TSB Revision



MFI CIRCUIT (1994 MODELS) <NON TURBO> (CONTINUED)

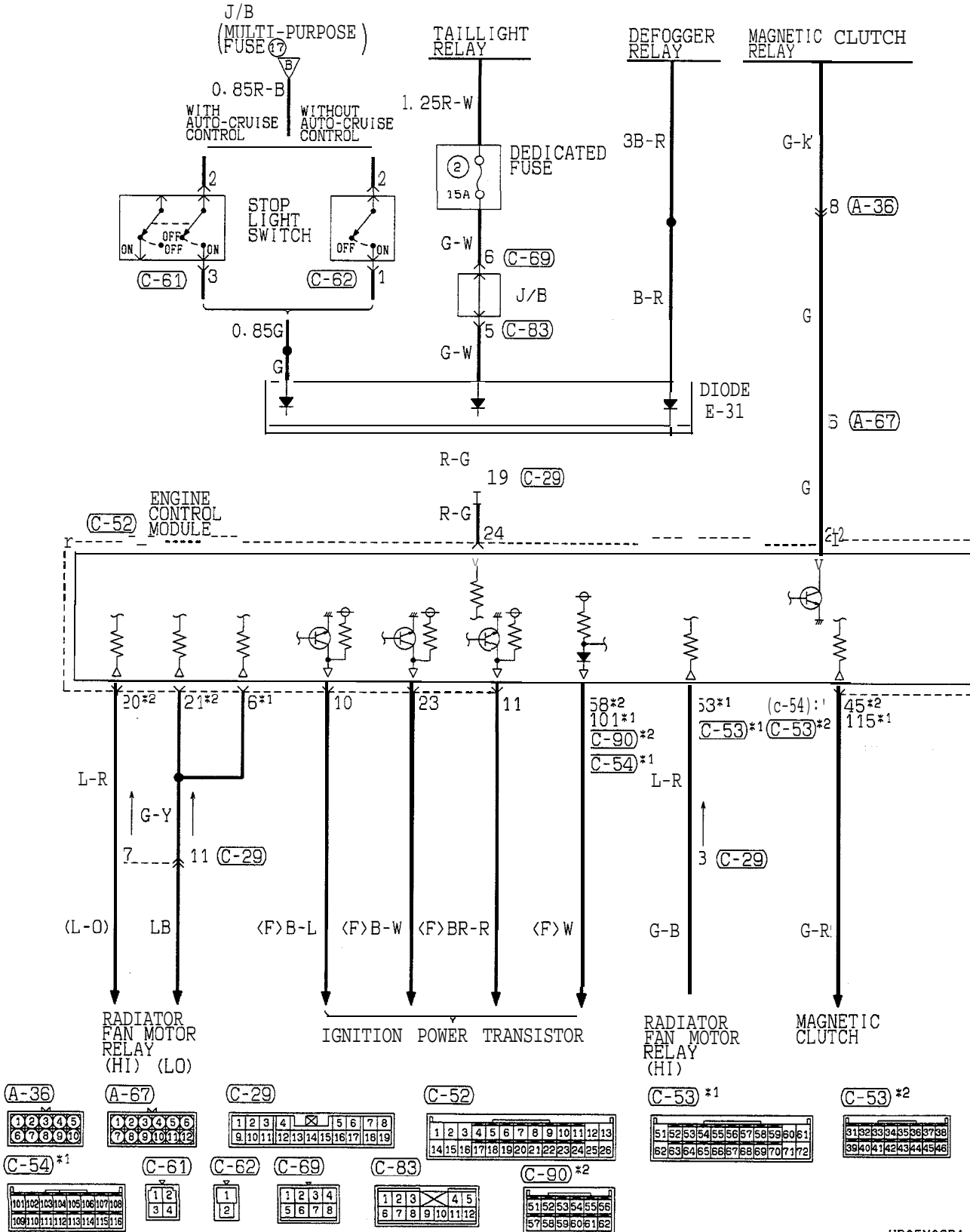

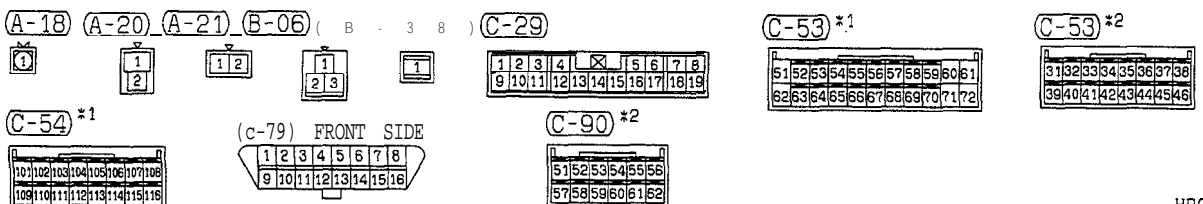
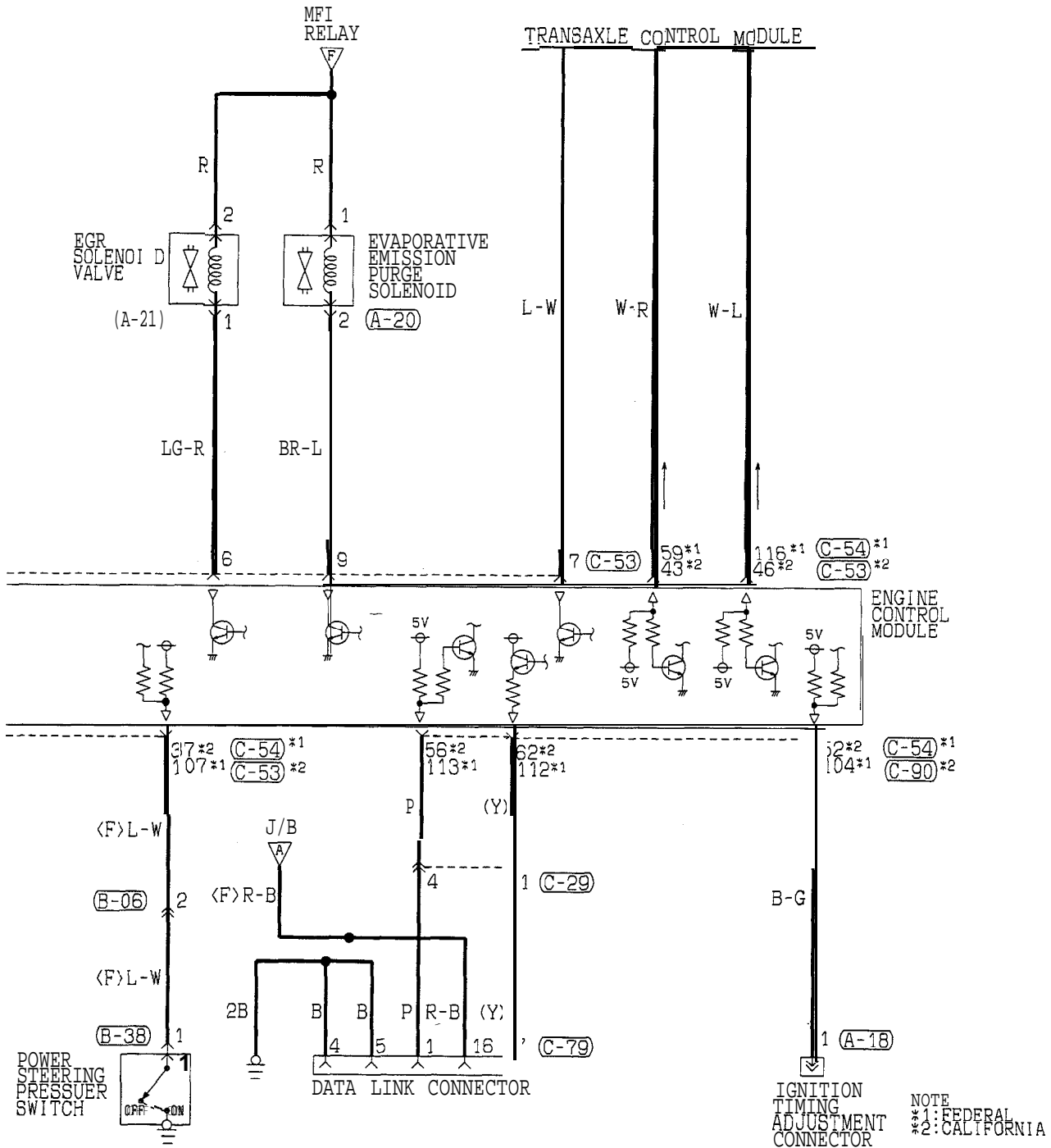

MFI CIRCUIT (1994 MODELS)

<TURBO>

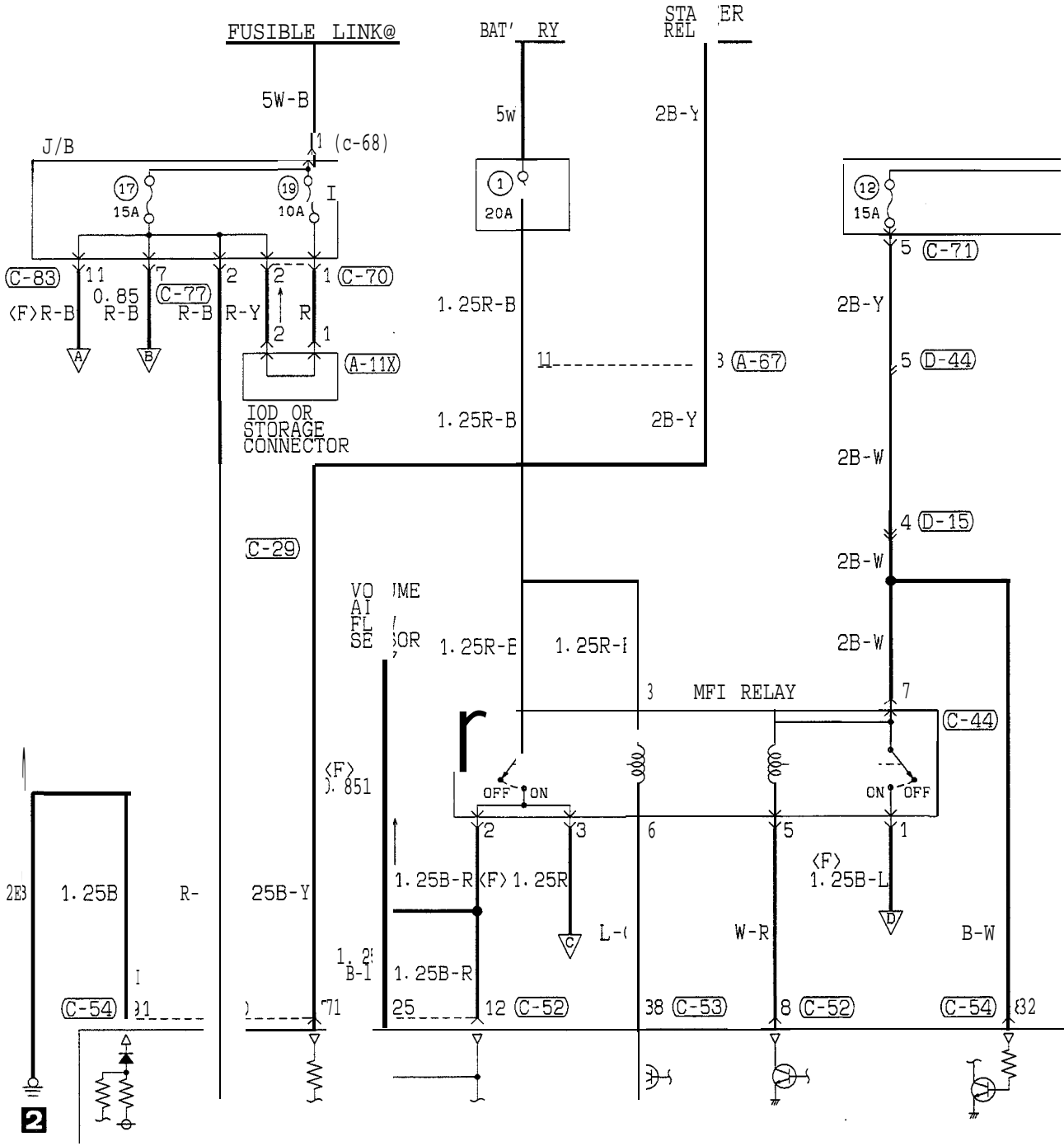

A-11X



A-67

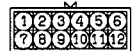

C-29

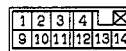

C-44



C-52

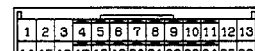

C-53

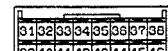

C-54

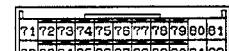

C-68



C-70

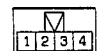

C-71

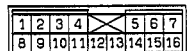

C-77

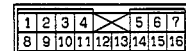

C-83

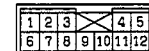

D-15

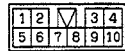

D-44

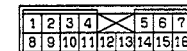

HR05M07AA

TSB Revision

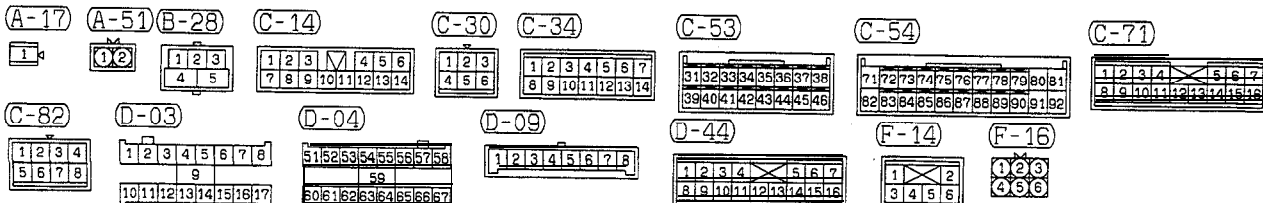
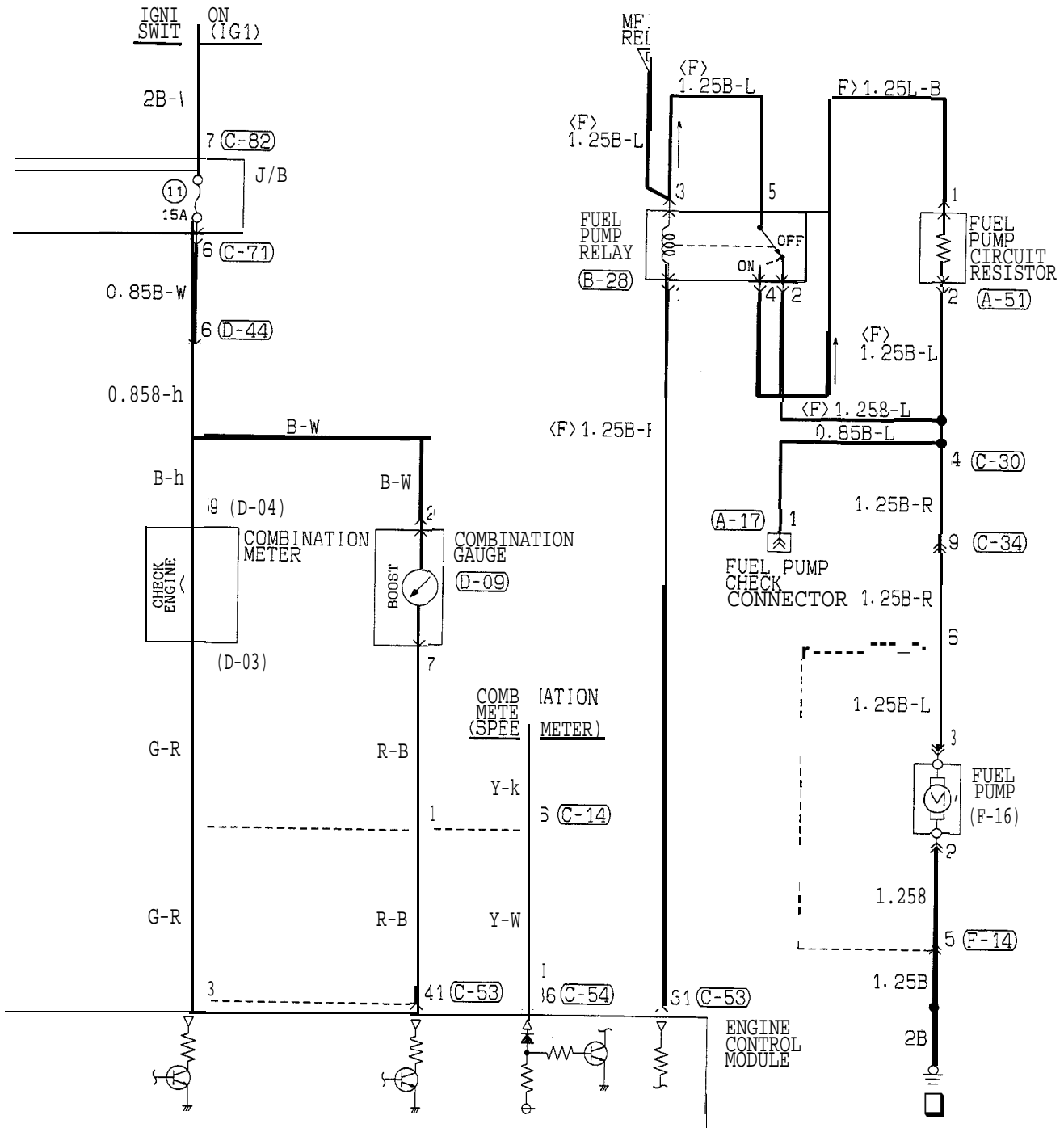

TSB Revision

MFI CIRCUIT (1994 MODELS) <TURBO> (CONTINUED)

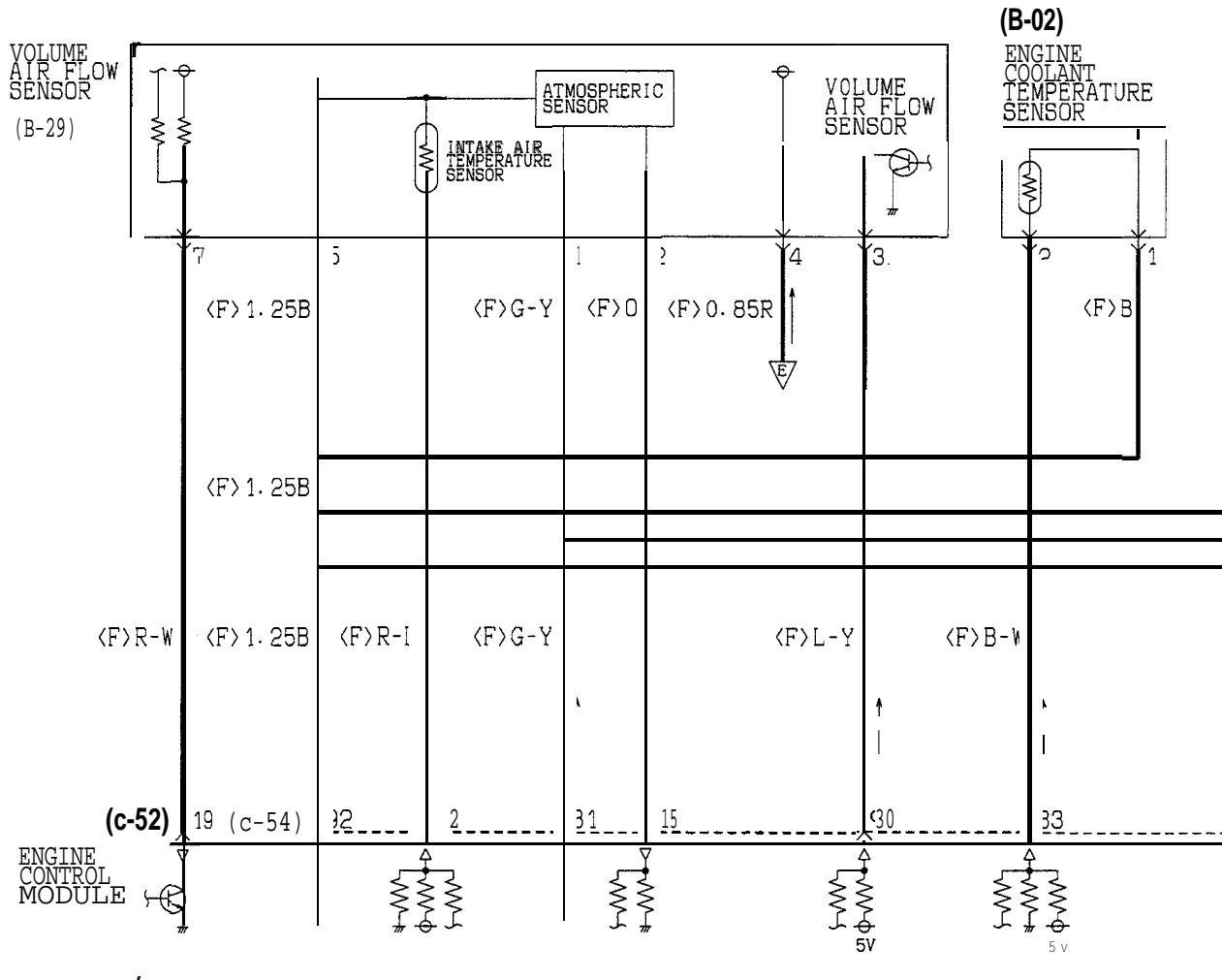

(B-02)

(B-29)

(C-52)

(C-54)

12
----

1	2	3	4	5	6	7	8	9	10	11	12	13
---	---	---	---	---	---	---	---	---	----	----	----	----

1	2	3	4	5	6	7	8	9	10	11	12	13
14	15	16	17	18	19	20	21	22	23	24	25	26

71	72	73	74	75	76	77	78	79	80	81
82	83	84	85	86	87	88	89	90	91	92

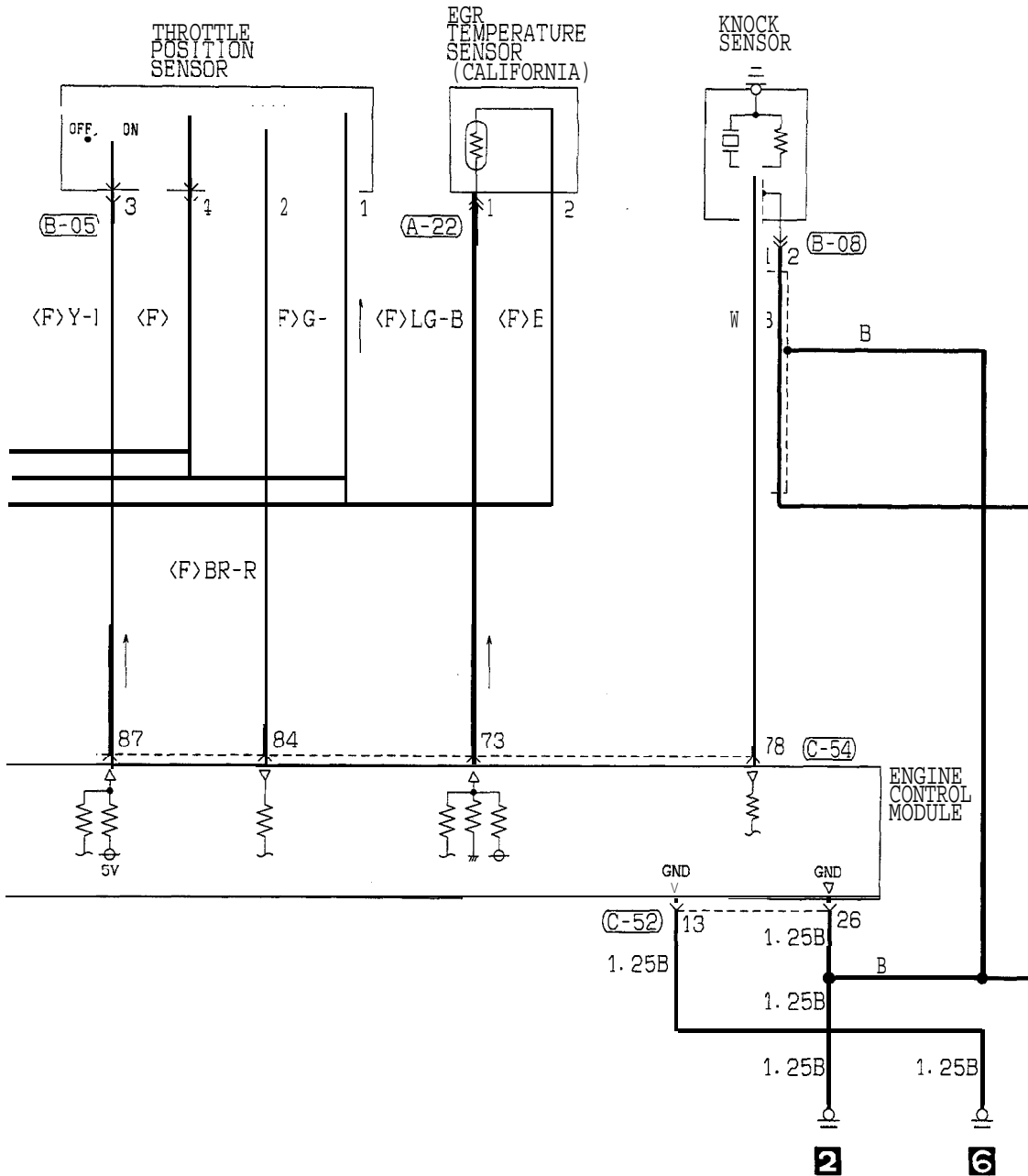

(A-22) (B-05)

(B-08) (C-52)

(C-54)



1	2	3	4	5	6	7	8	9	10	11	12	13
14	15	16	17	18	19	20	21	22	23	24	25	26

71	72	73	74	75	76	77	78	79	80	81
82	83	84	85	86	87	88	89	90	91	92

TSB Revision

MFI CIRCUIT (1994 MODELS) <TURBO> (CONTINUED)

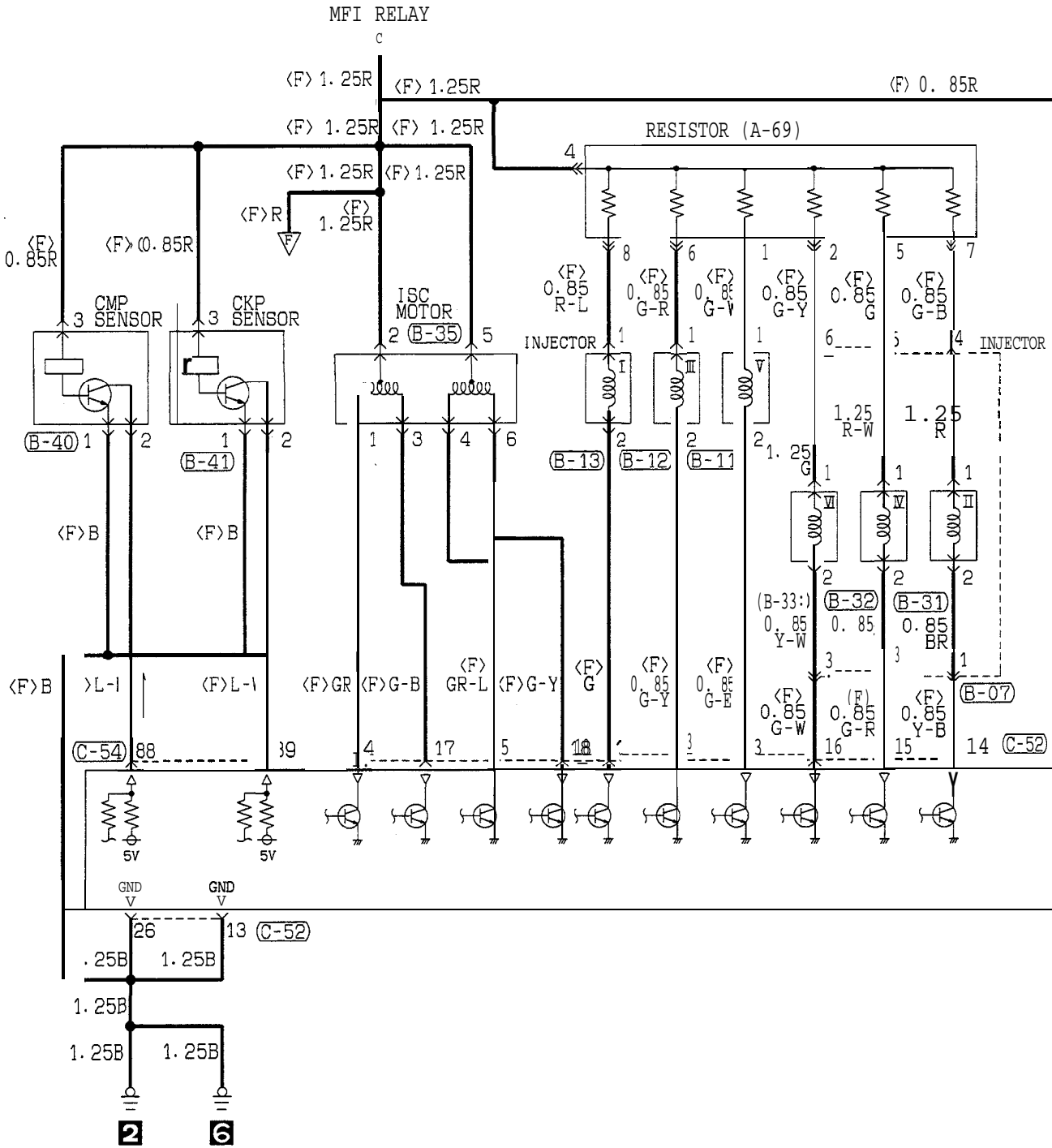

- (A-69)
- (B-07)
- (B-11)
- (B-12)
- (B-13)
- (B-31)
- (B-32)
- (B-33)
- (B-35)
- (B-40)
- (B-41)

- (C-52)
- (C-54)

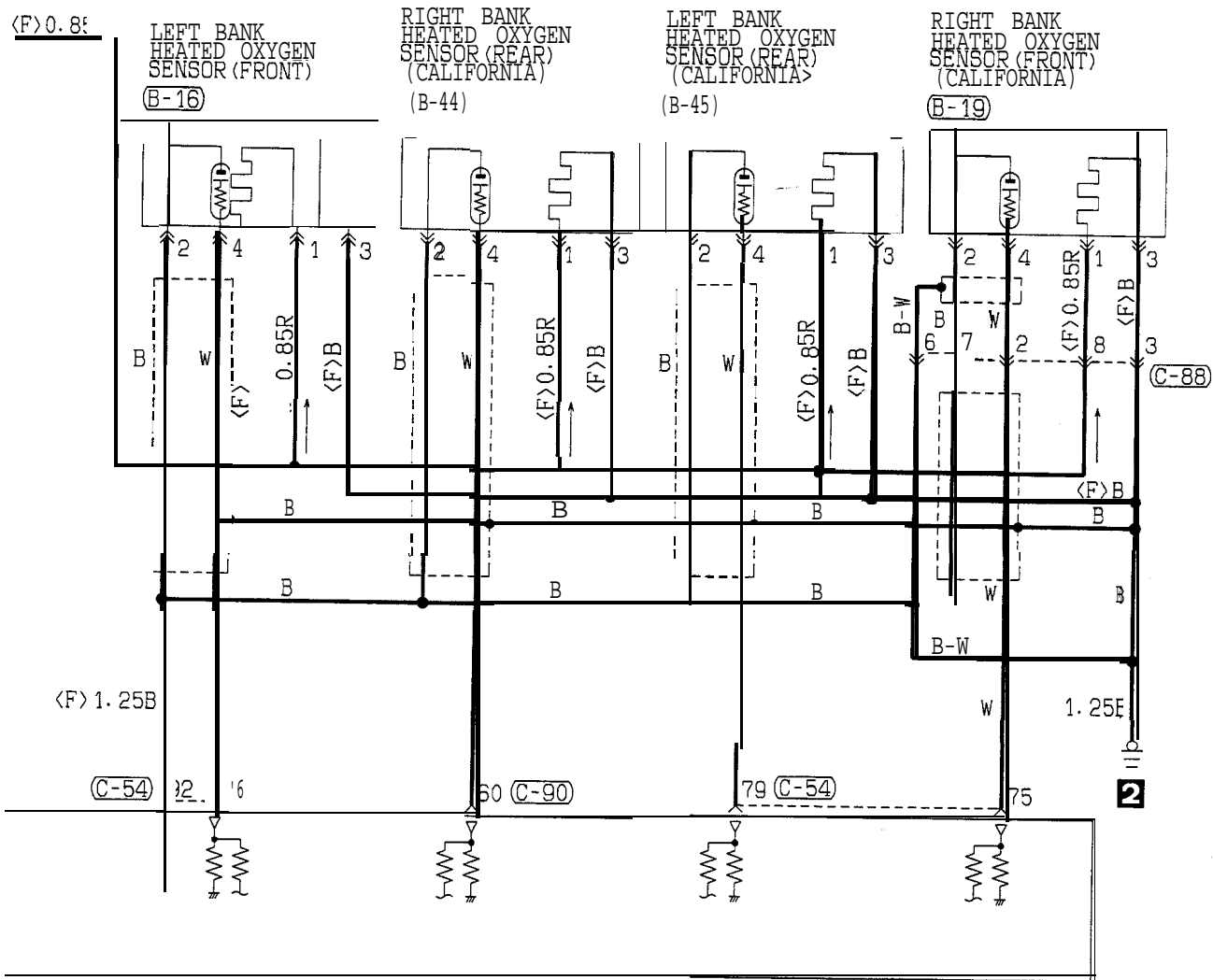

(B-16)



(B-19)



(B-44)



(B-45)



(C-54)

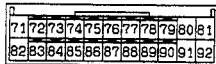

(C-88)



(C-90)

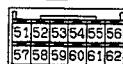



MFI CIRCUIT (1994 MODELS) <TURBO> (CONTINUED)

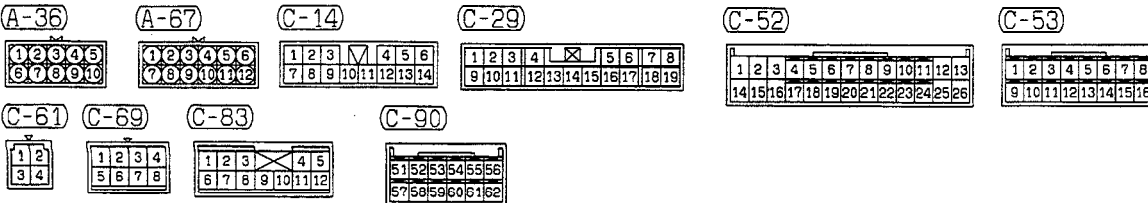
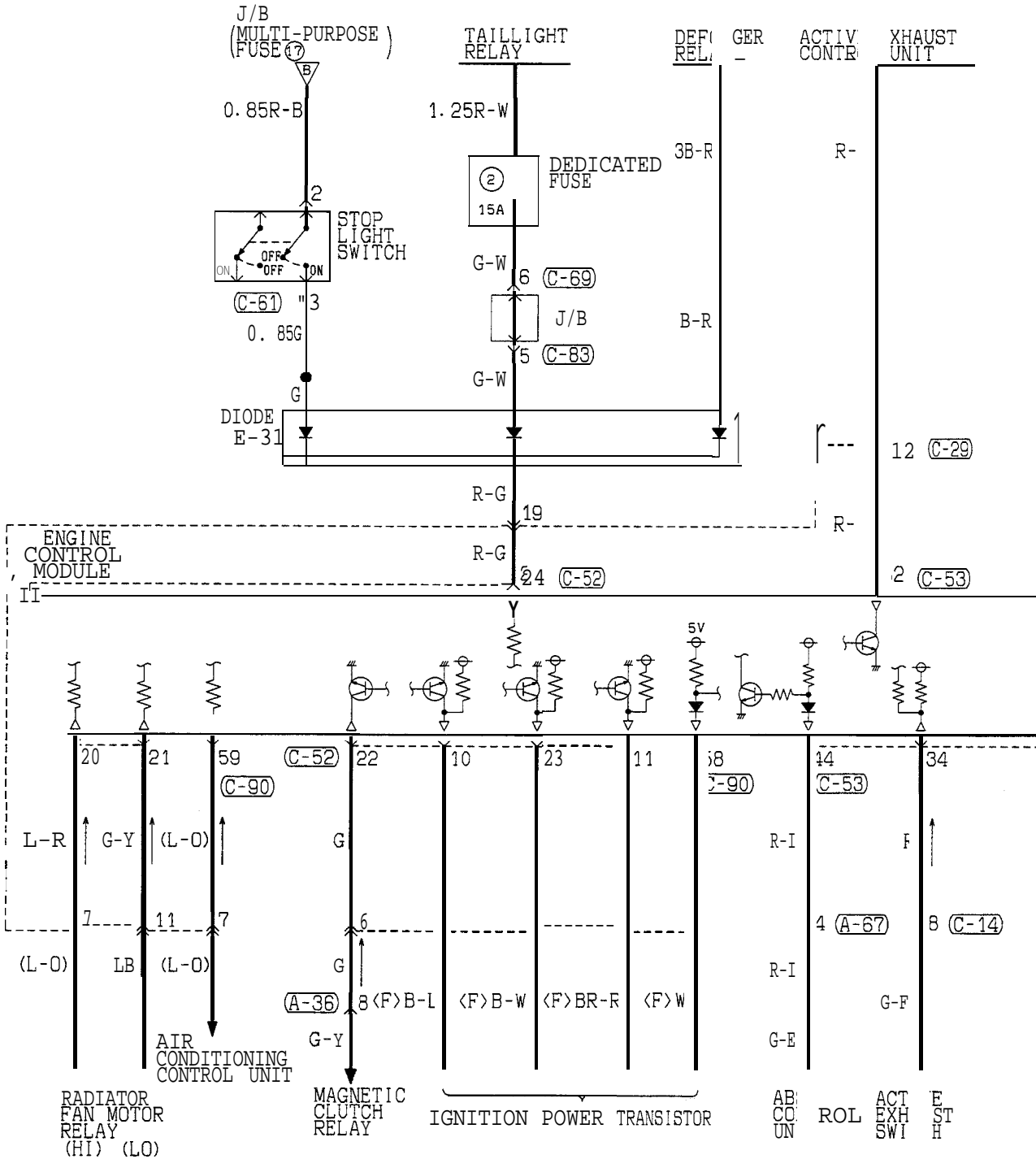

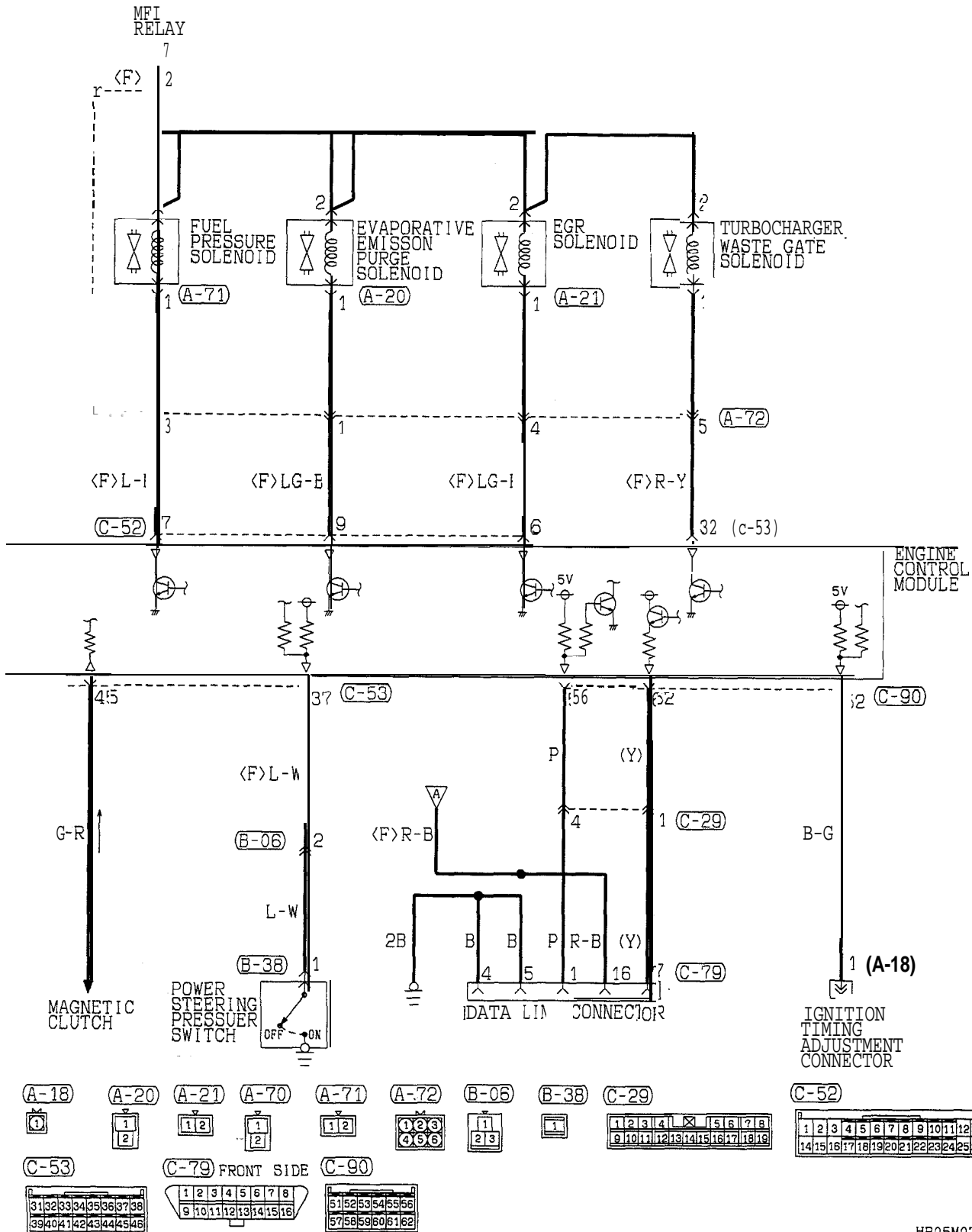

HR05M07DB

TSB Revision

MFI CIRCUIT (1995 MODELS)

<NON TURBO> (FEDERAL)

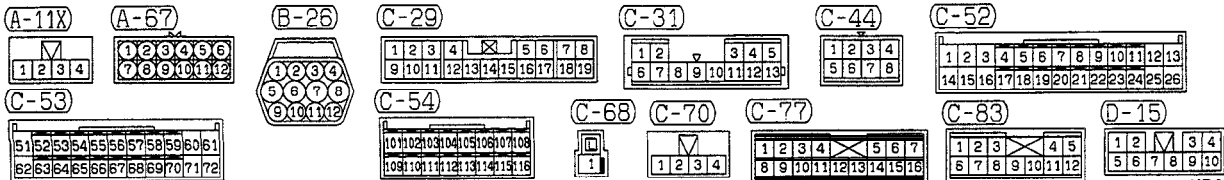
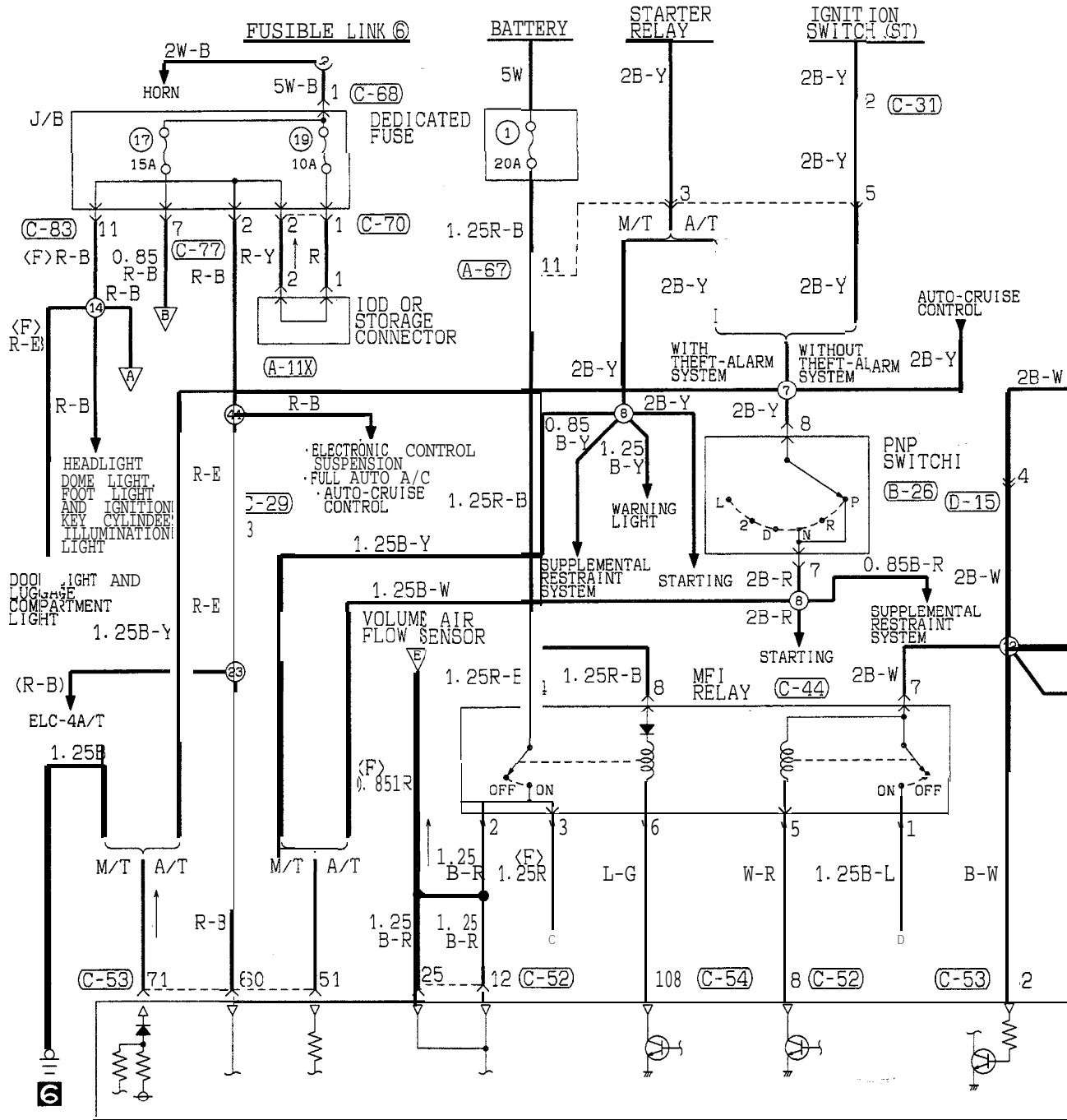

HR05M03AA

TSB Revision

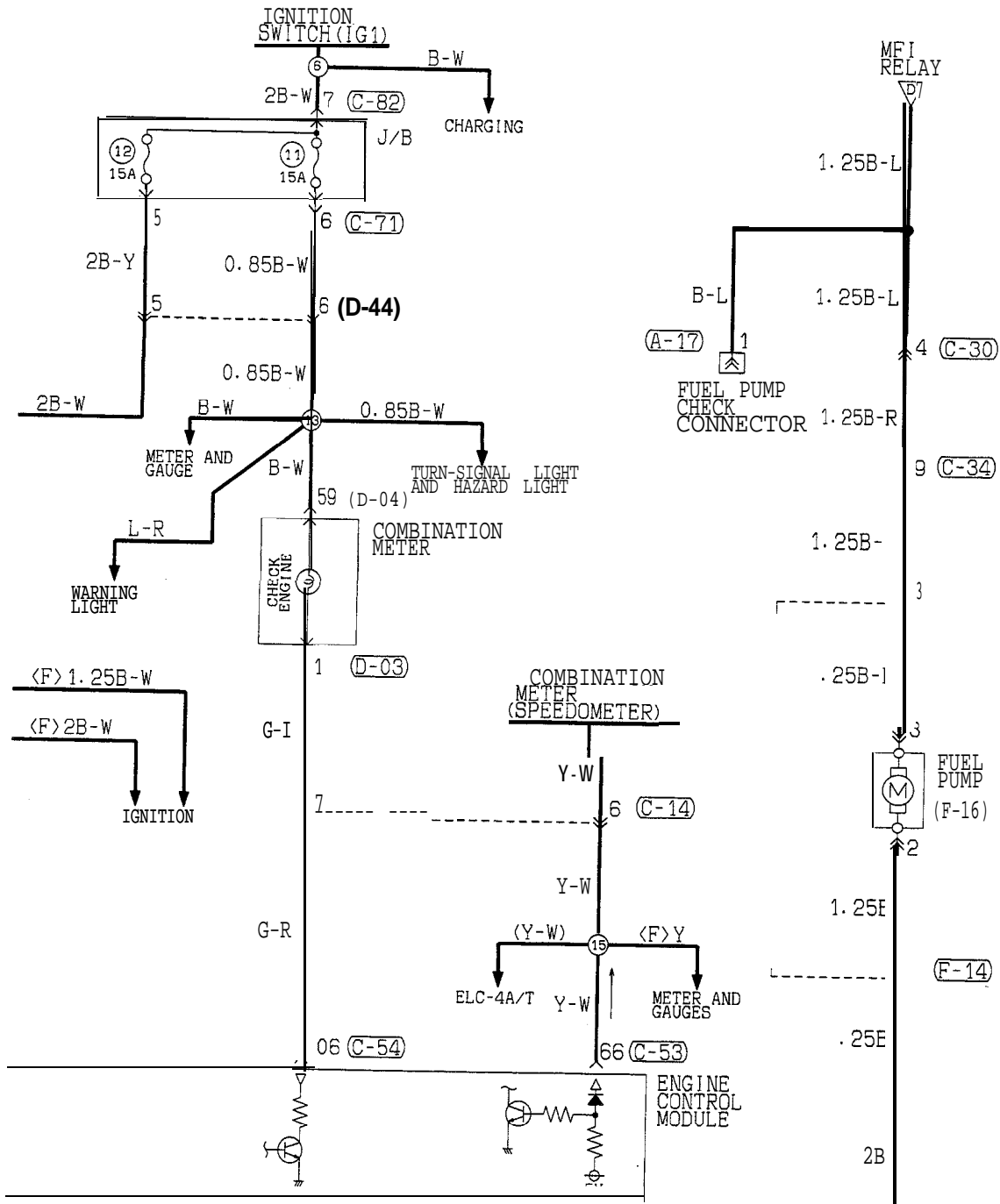

10

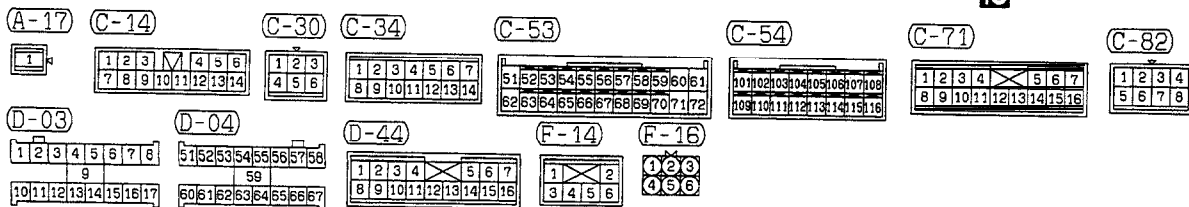

TSB Revision

MFI CIRCUIT (1995 MODELS) <NON TURBO> (FEDERAL) (CONTINUED)

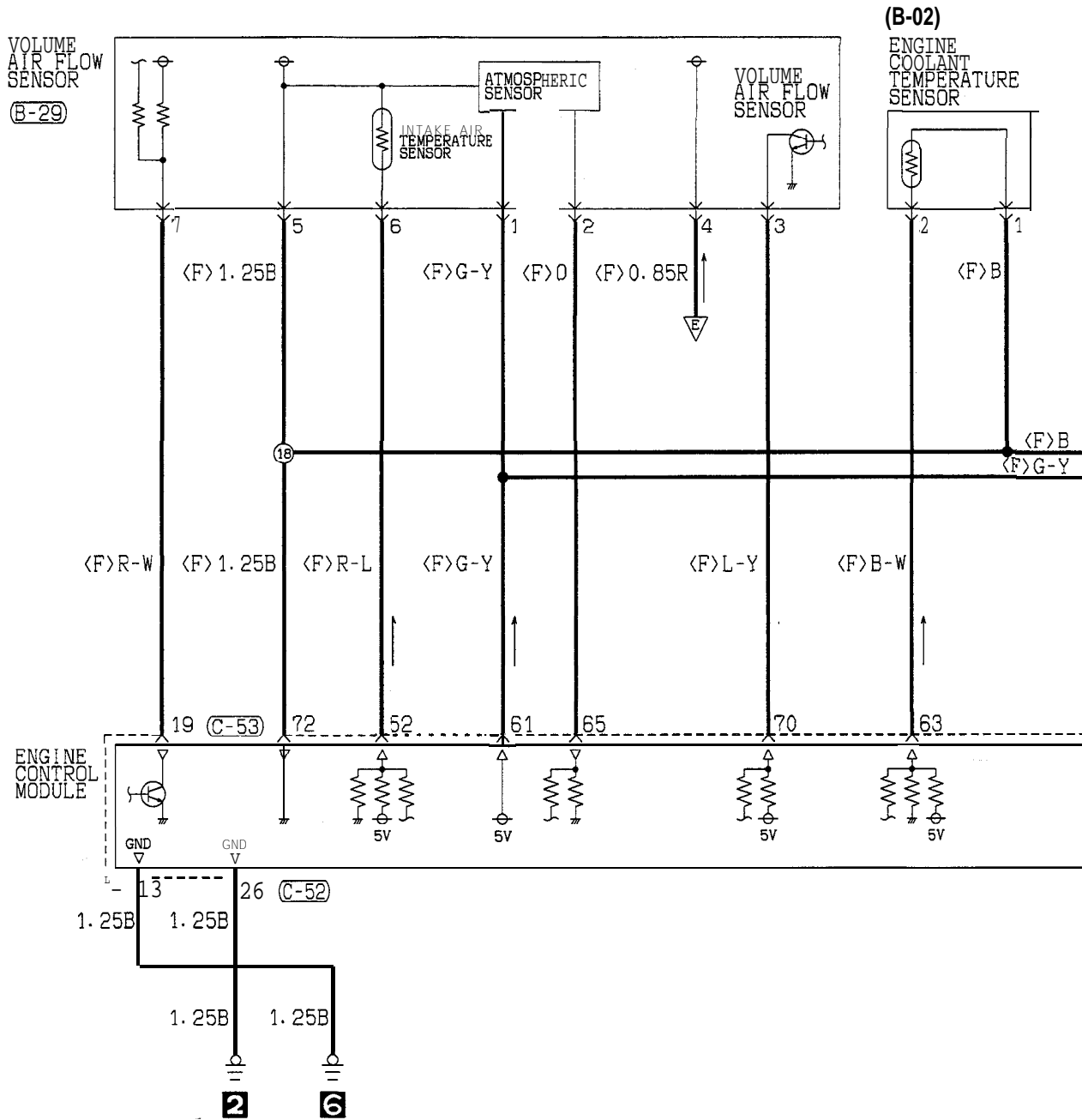

B-02

B-29

C-52

C-53

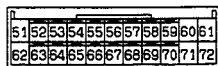
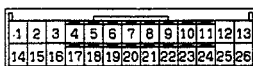

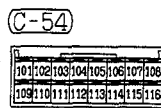
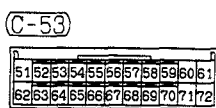
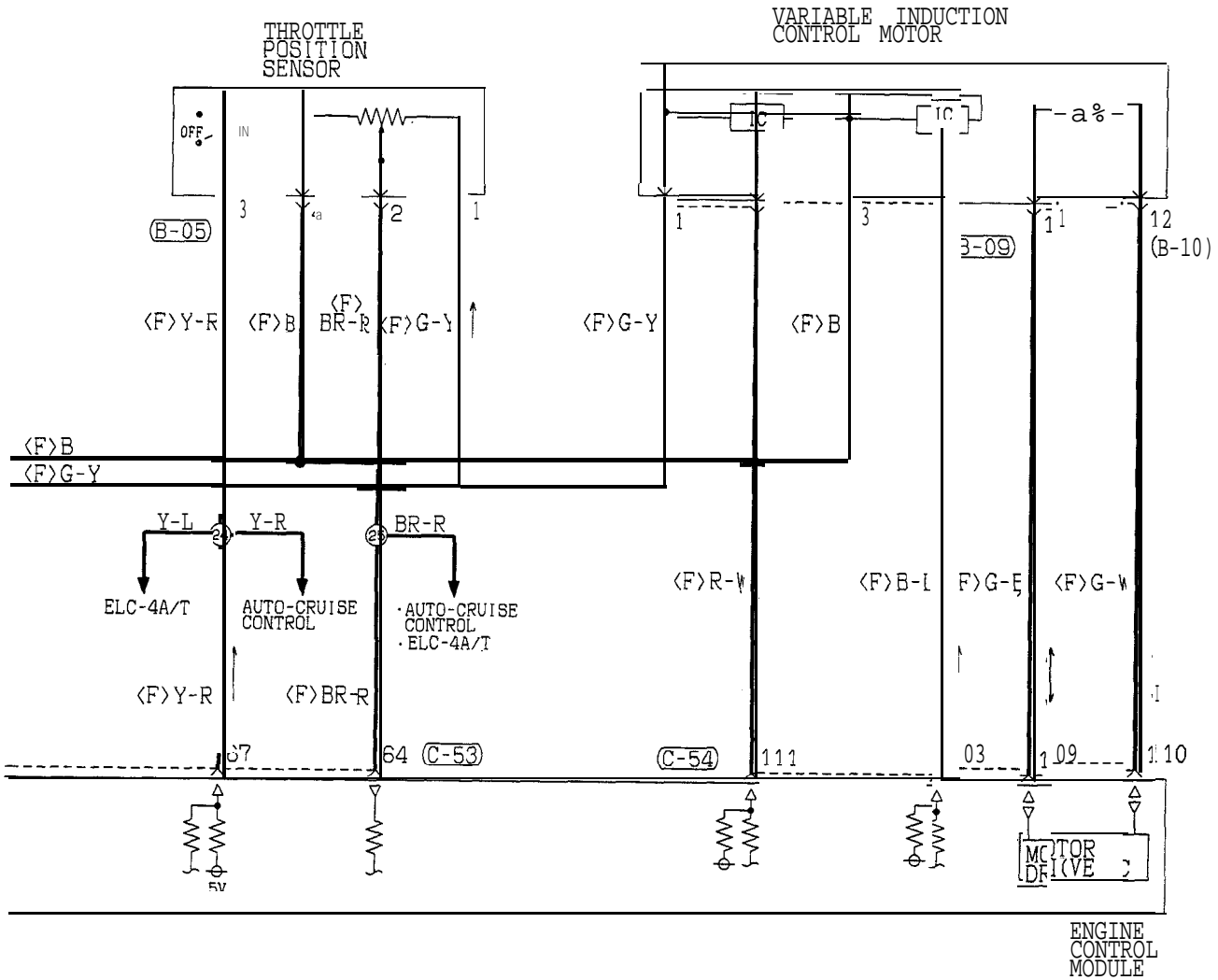

MFI CIRCUIT (1995 MODELS) <NON TURBO> (FEDERAL) (CONTINUED)

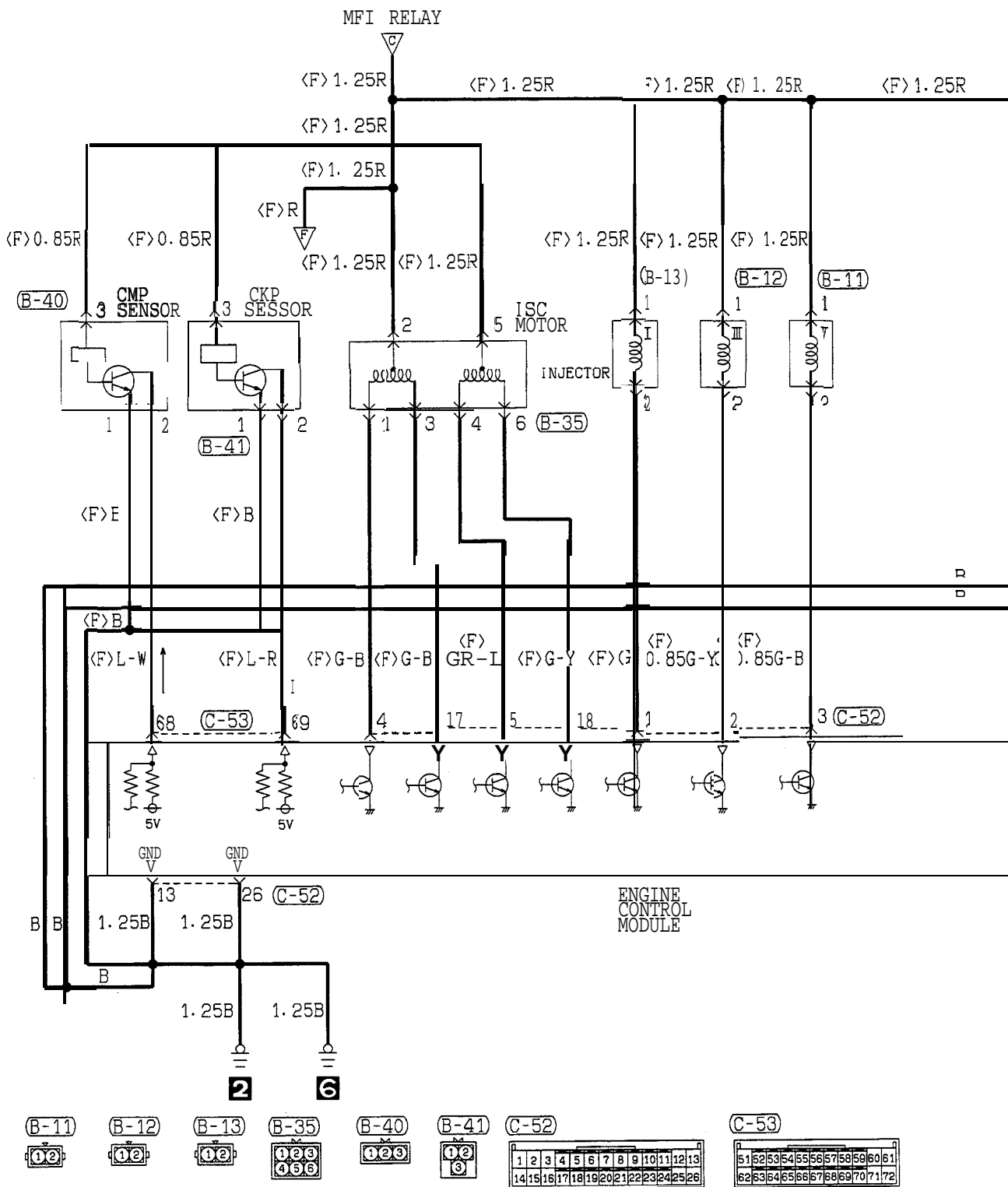

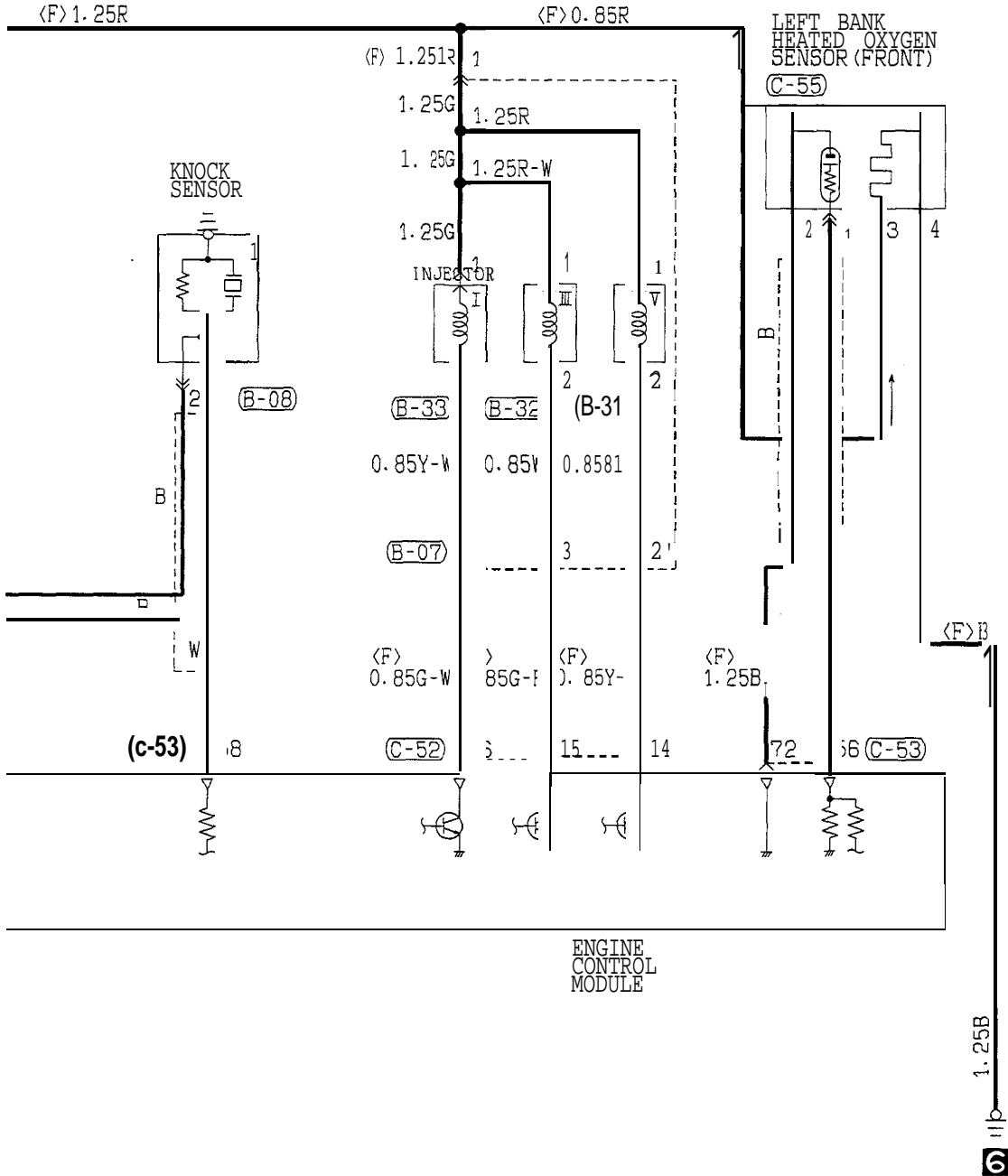

B-07



B-08



B-19



B-31



B-32



B-33



B-44



B-45



C-52

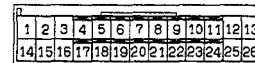

C-53

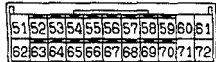

C-55





MFI CIRCUIT (1995 MODELS) <NON TURBO> (FEDERAL) (CONTINUED)

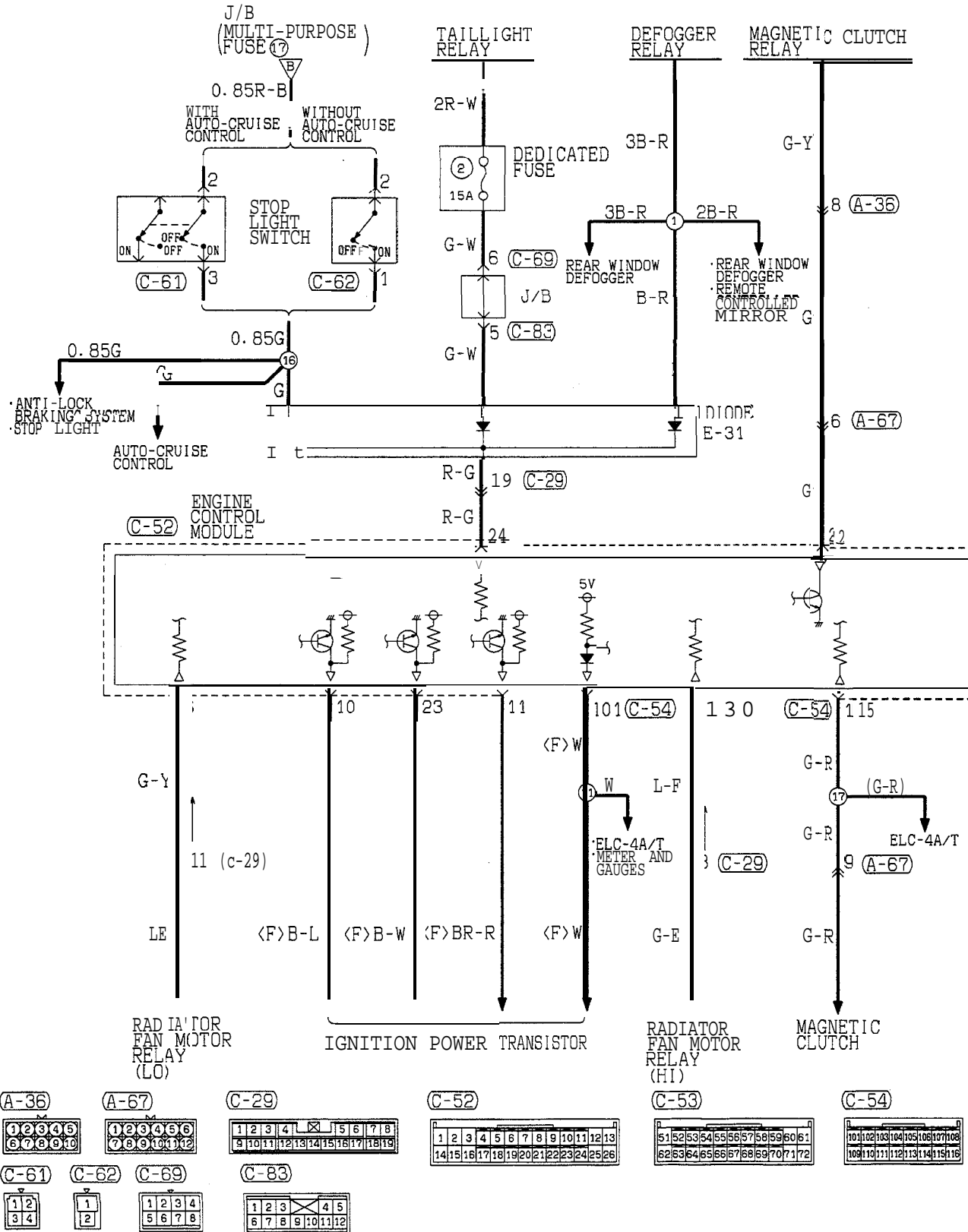

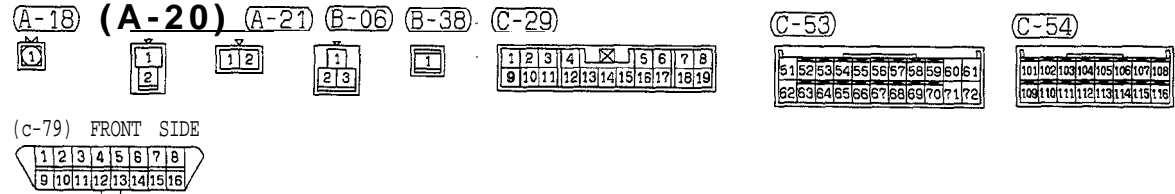
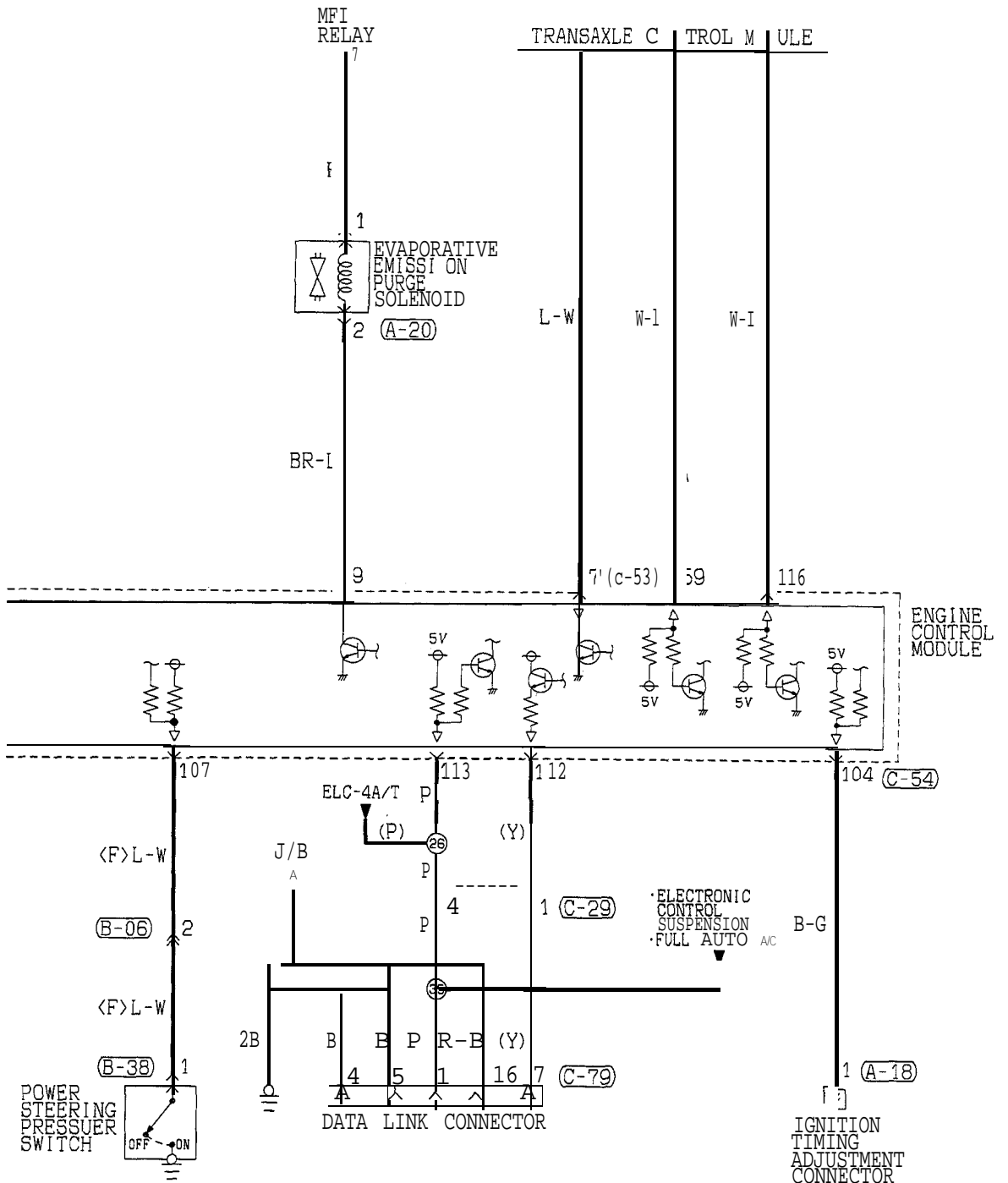

MFI CIRCUIT (1995 MODELS)

<NON TURBO> (CALIFORNIA)

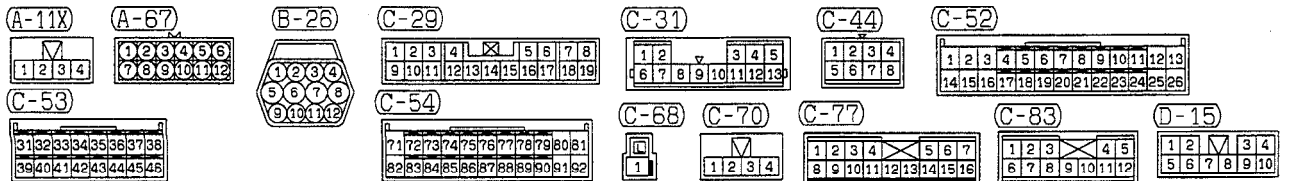
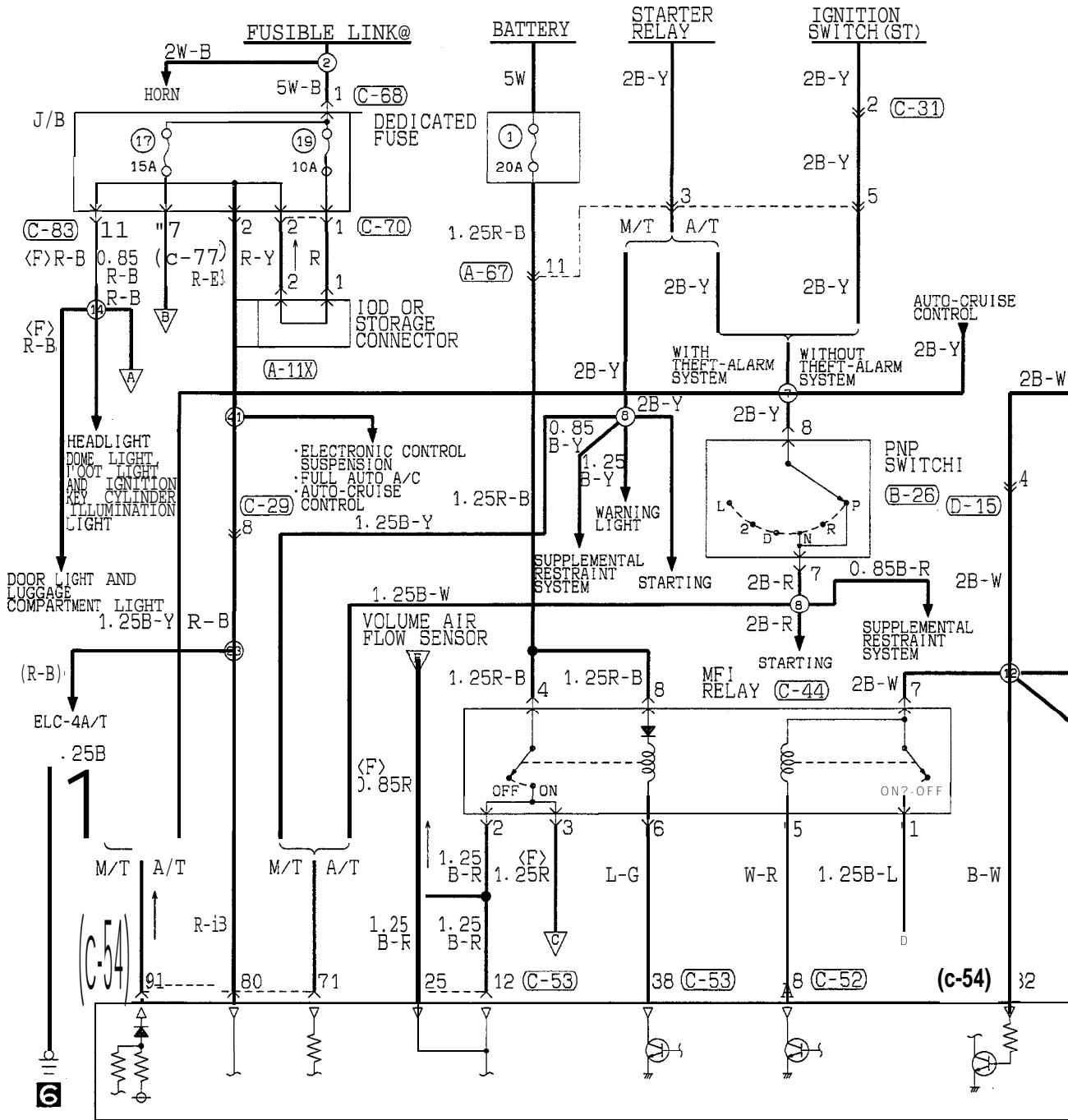

HR05M04AA

TSB Revision

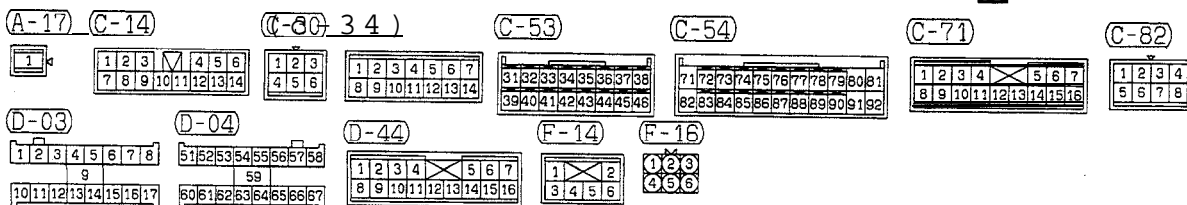
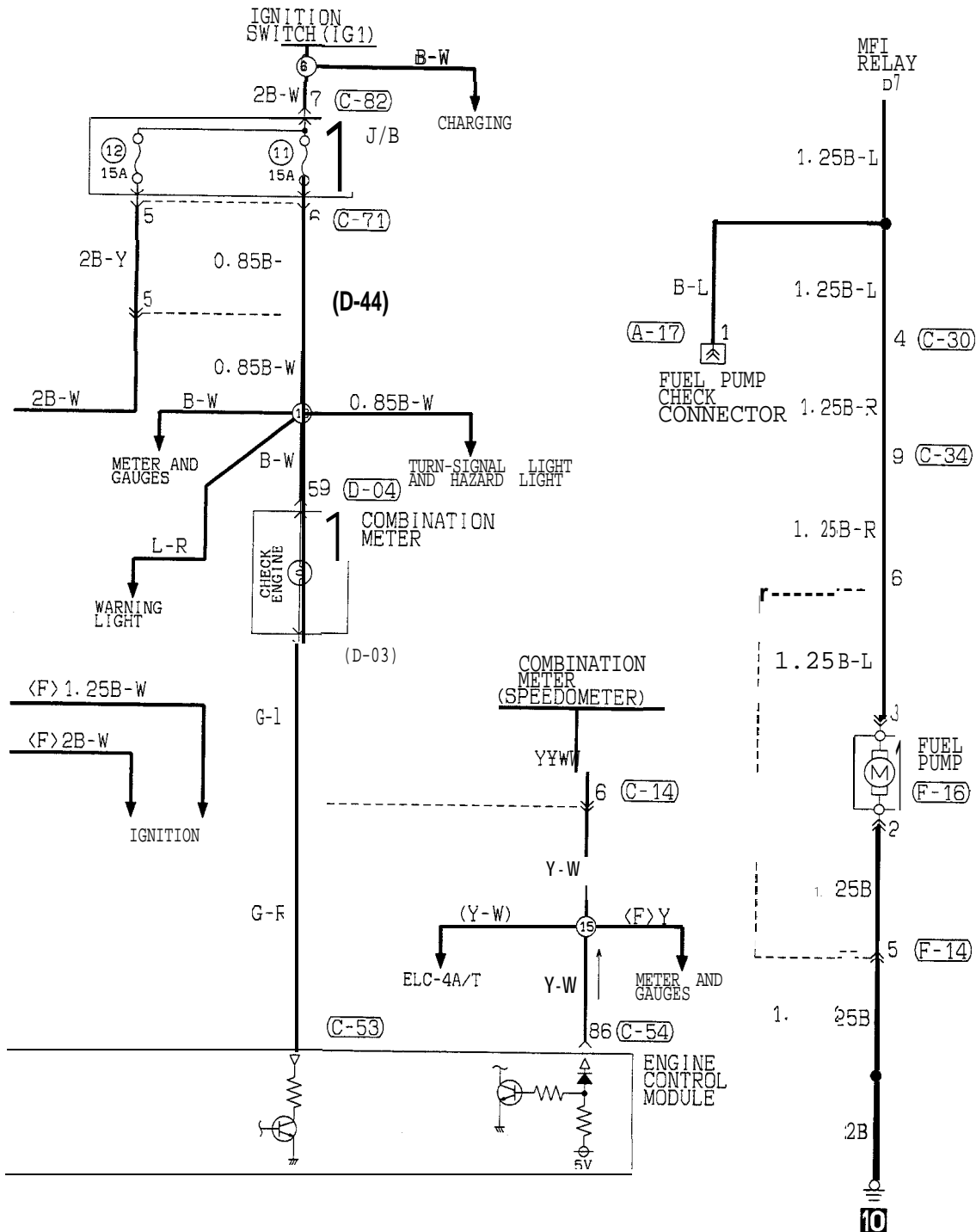

TSB Revision

MFI CIRCUIT (1995 MODELS) <NON TURBO> (CALIFORNIA) (CONTINUED)

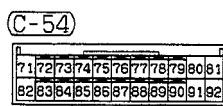
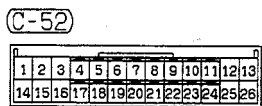
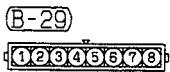
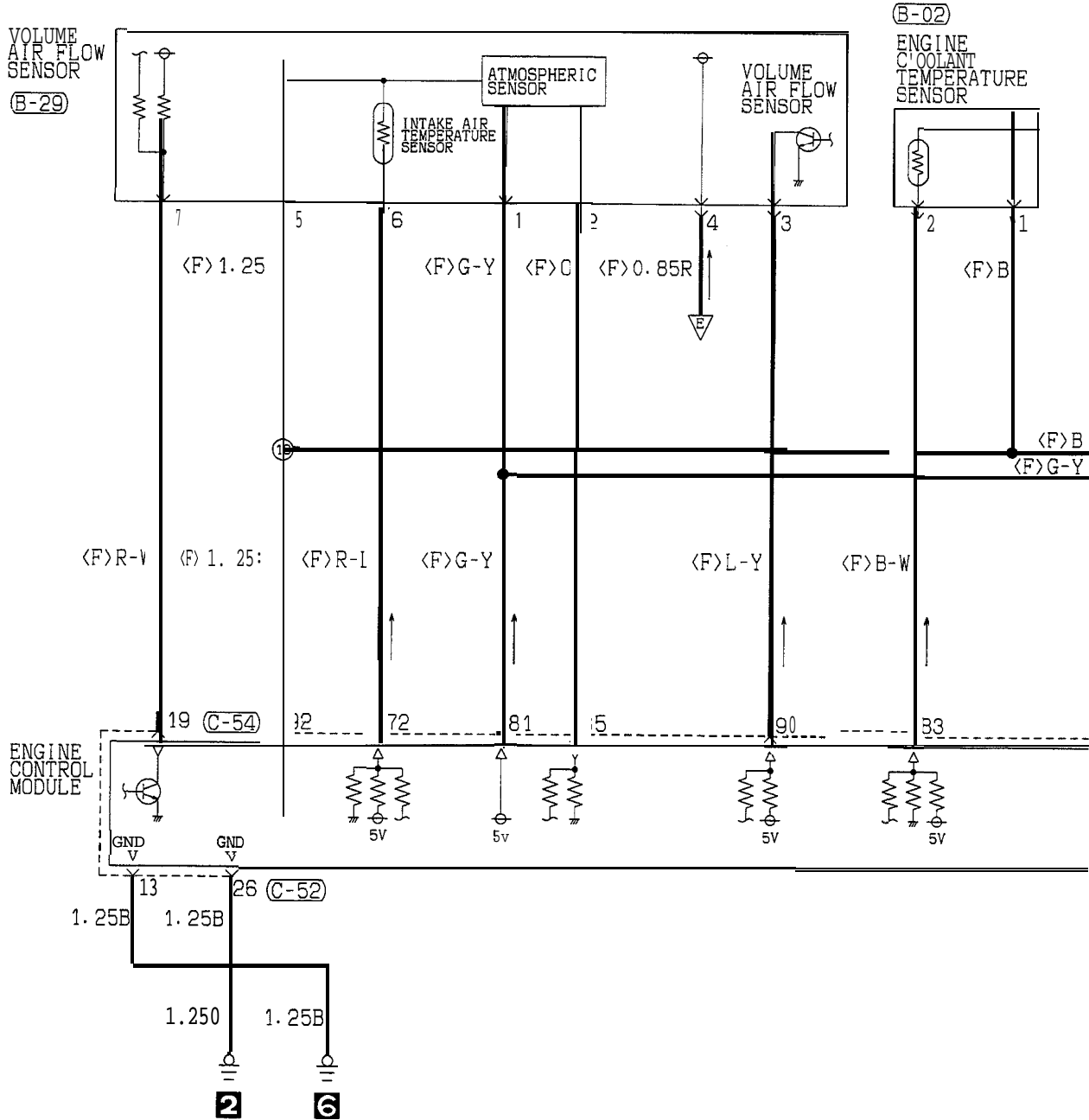

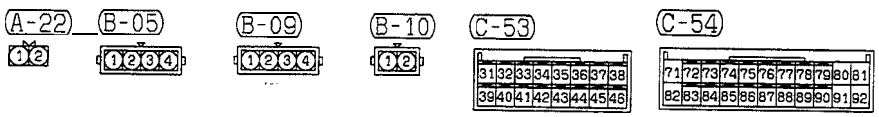
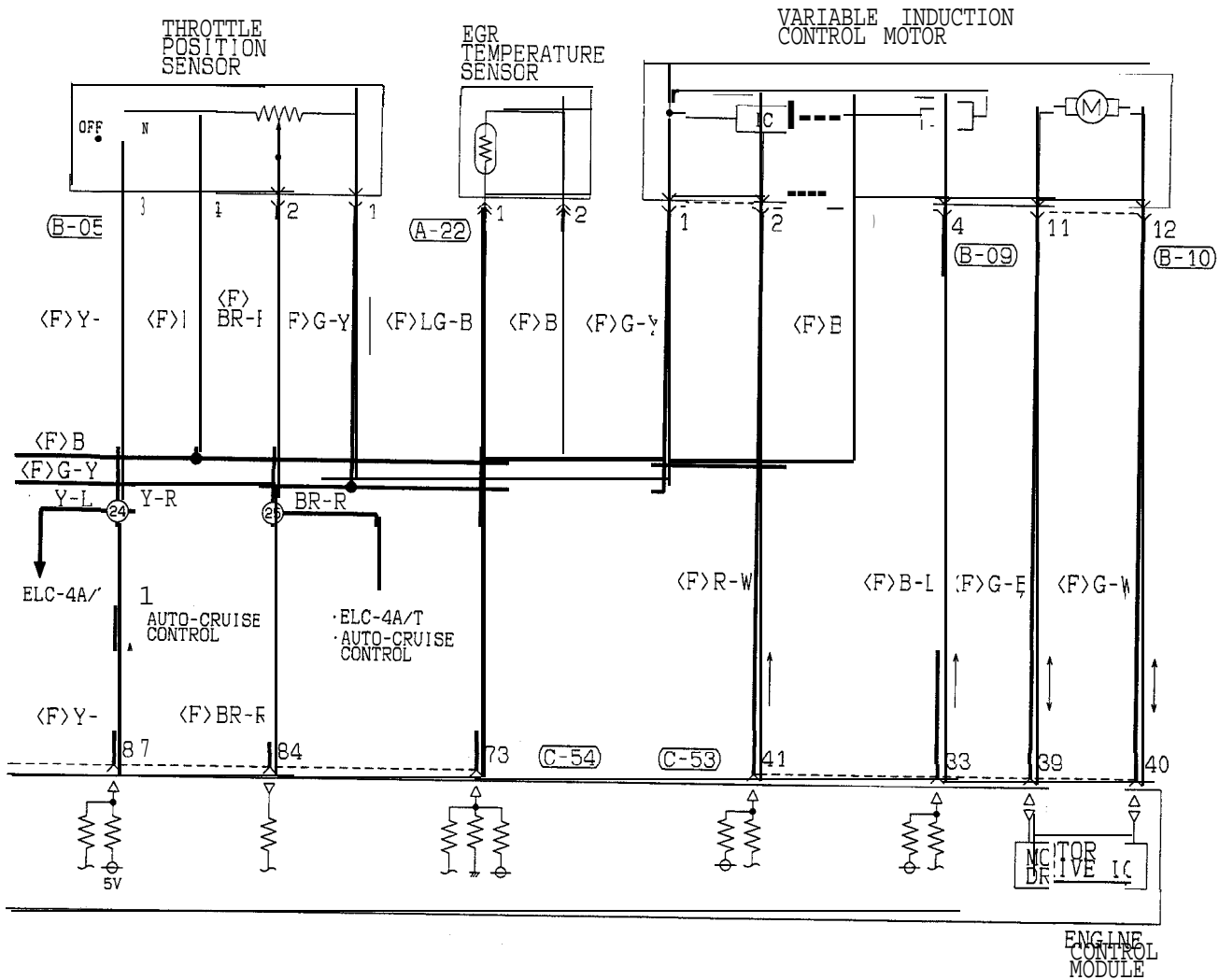

MFI CIRCUIT (1995 MODELS) <NON TURBO> (CALIFORNIA) (CONTINUED)

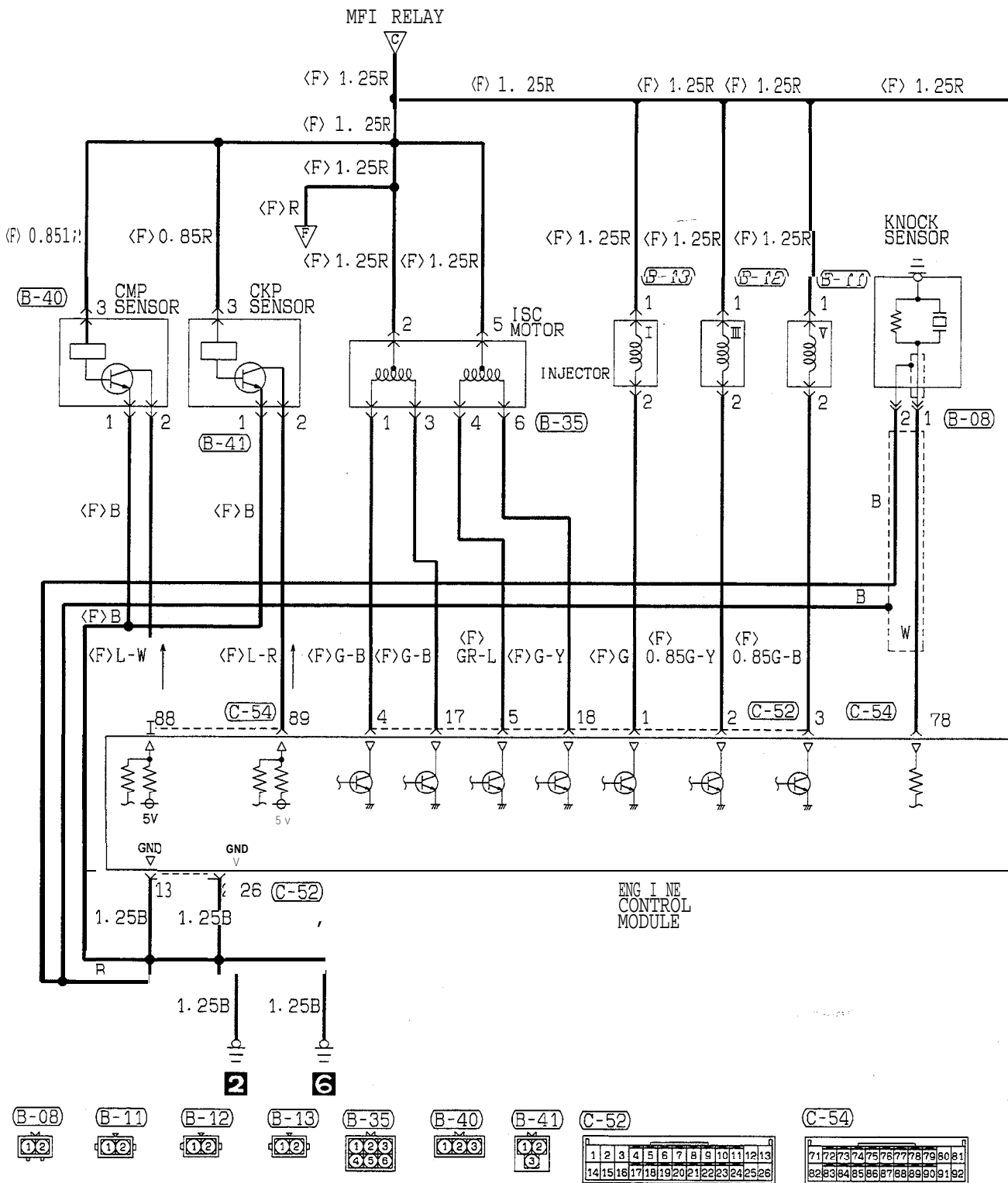

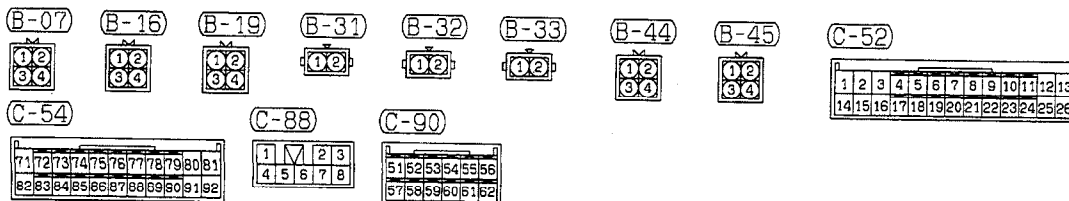
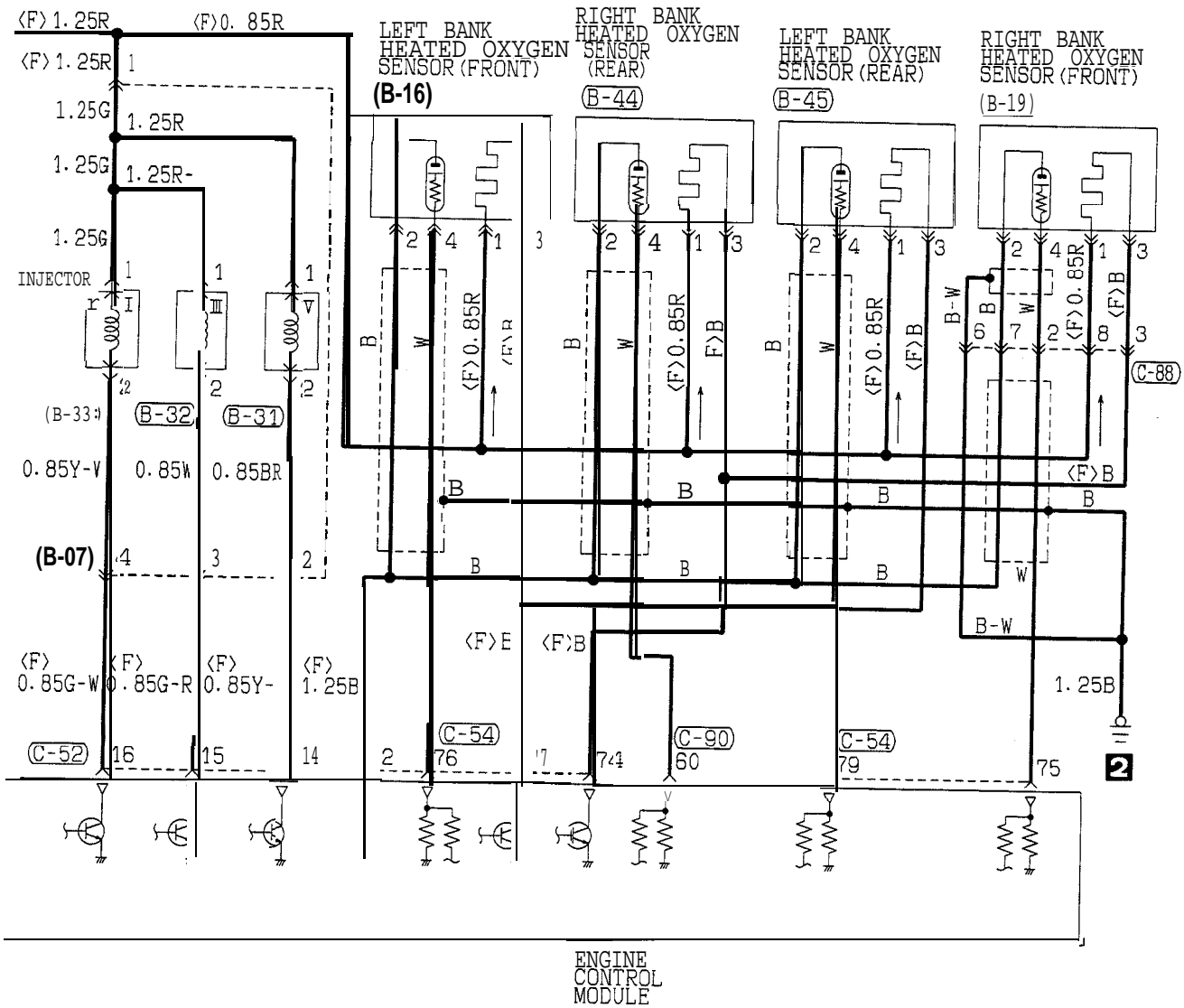

TSB Revision.



MFI CIRCUIT (1995 MODELS) <NON TURBO> (CALIFORNIA) (CONTINUED)

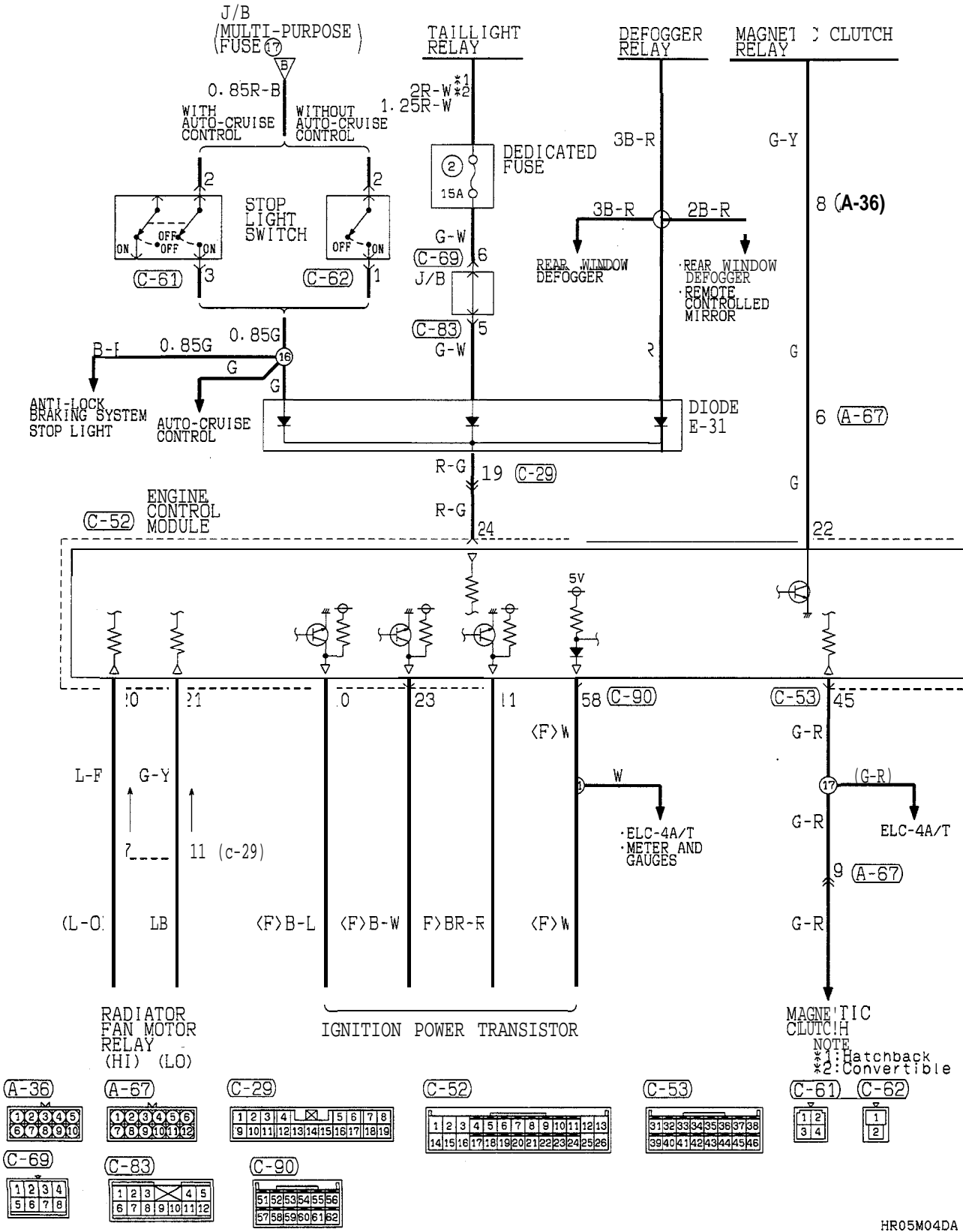

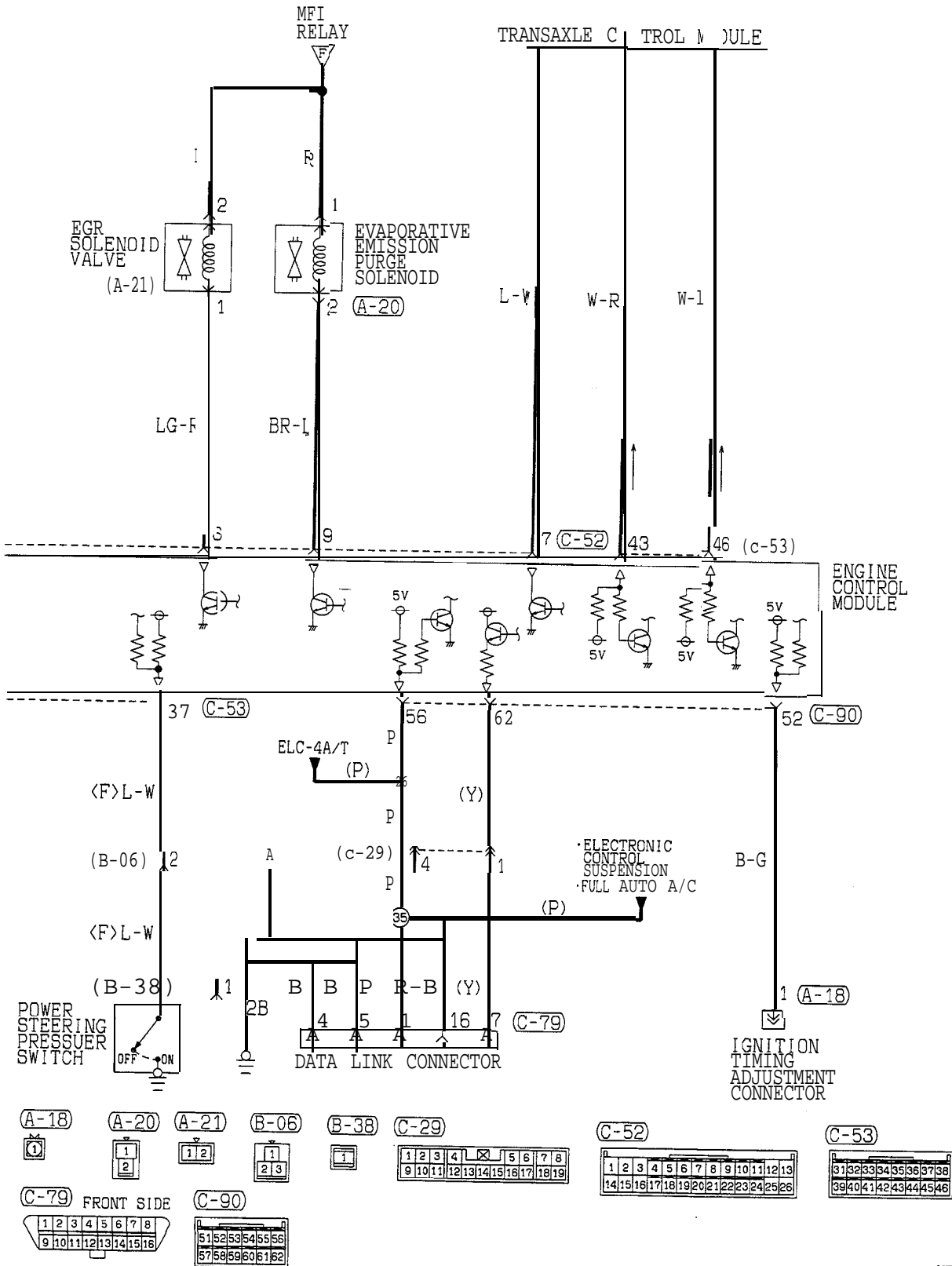

HR05M04DB

TSB Revision

MFI CIRCUIT (1995 MODELS)

<TURBO>

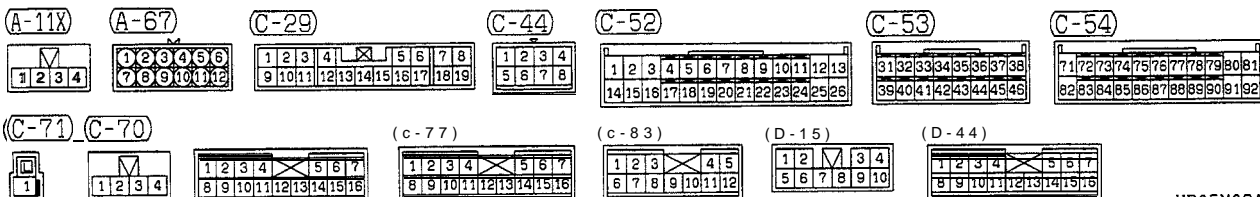
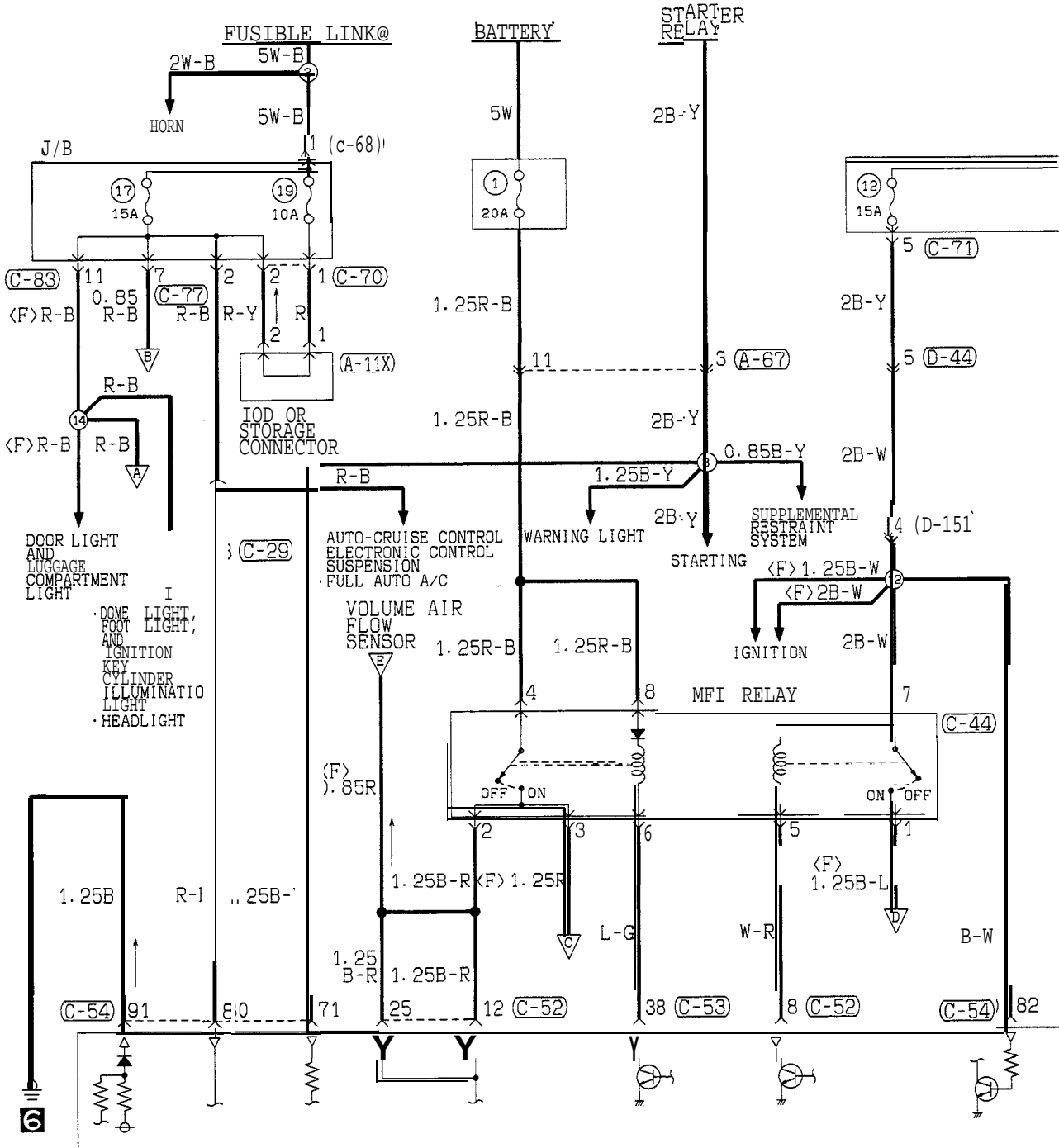

HR05M08AA

TSB Revision

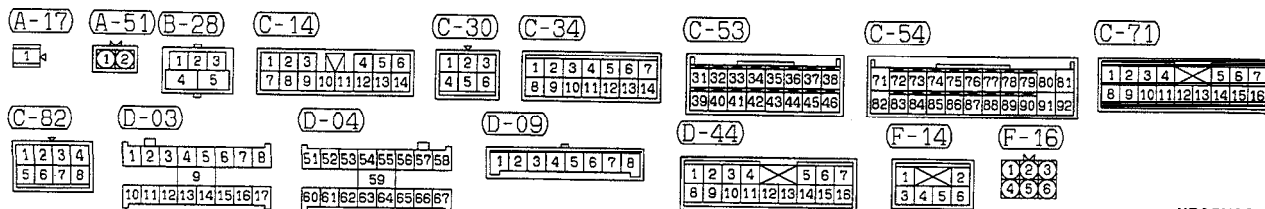
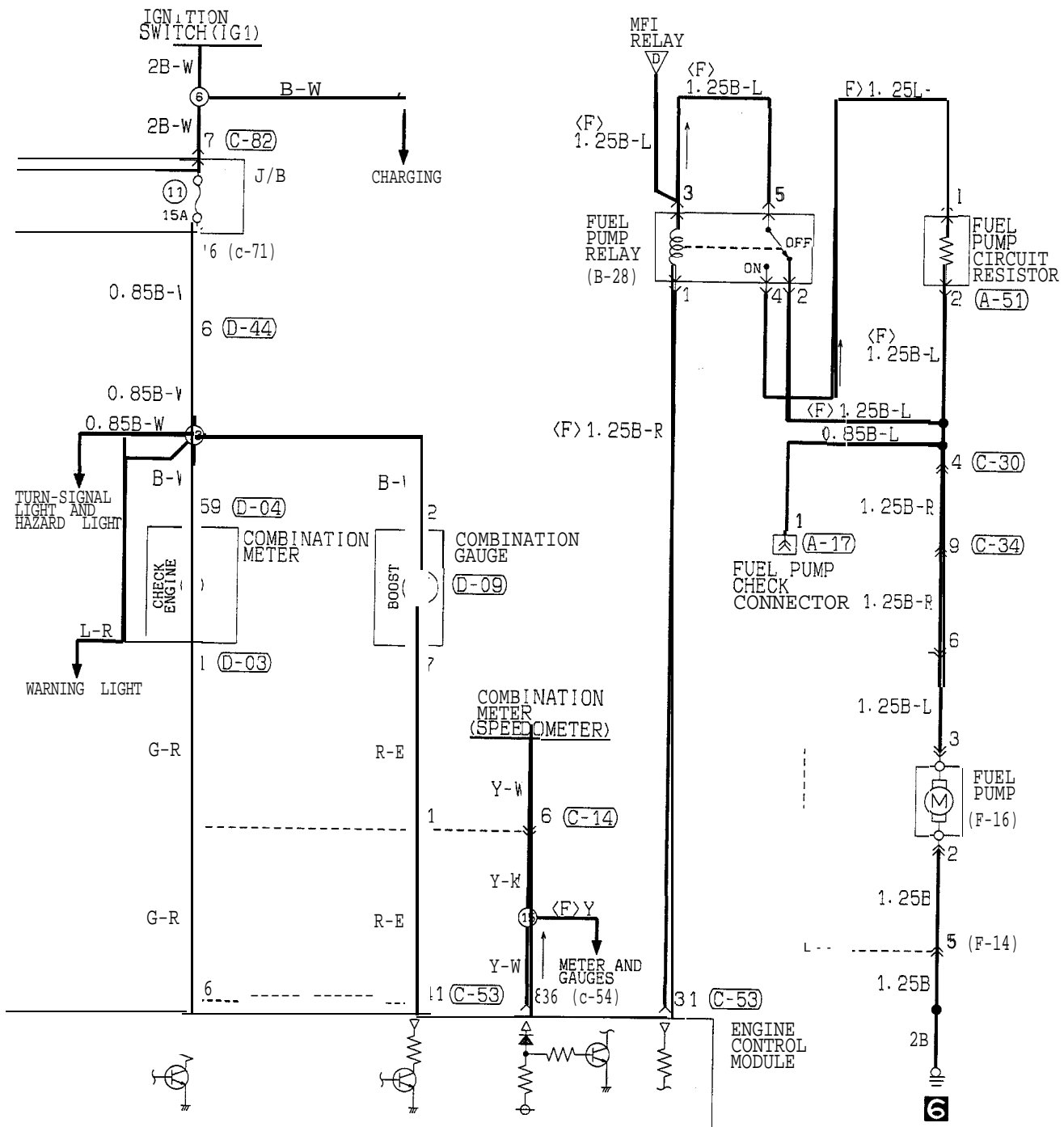

TSB Revision

MFI CIRCUIT (1995 MODELS) <TURBO> (CONTINUED)

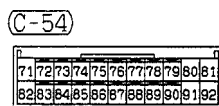
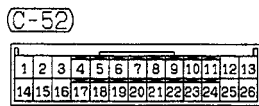
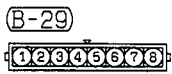
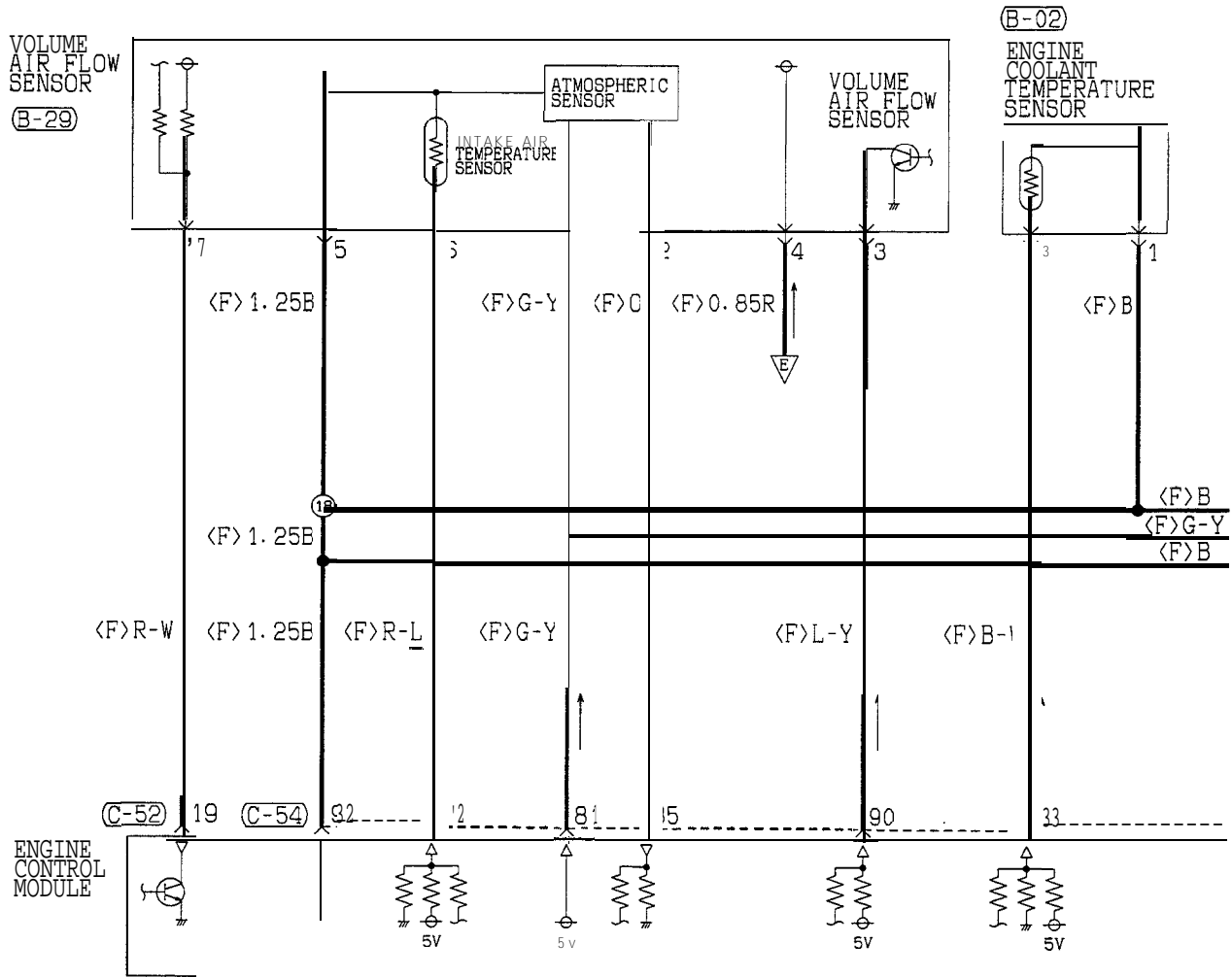

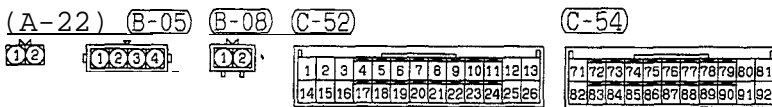
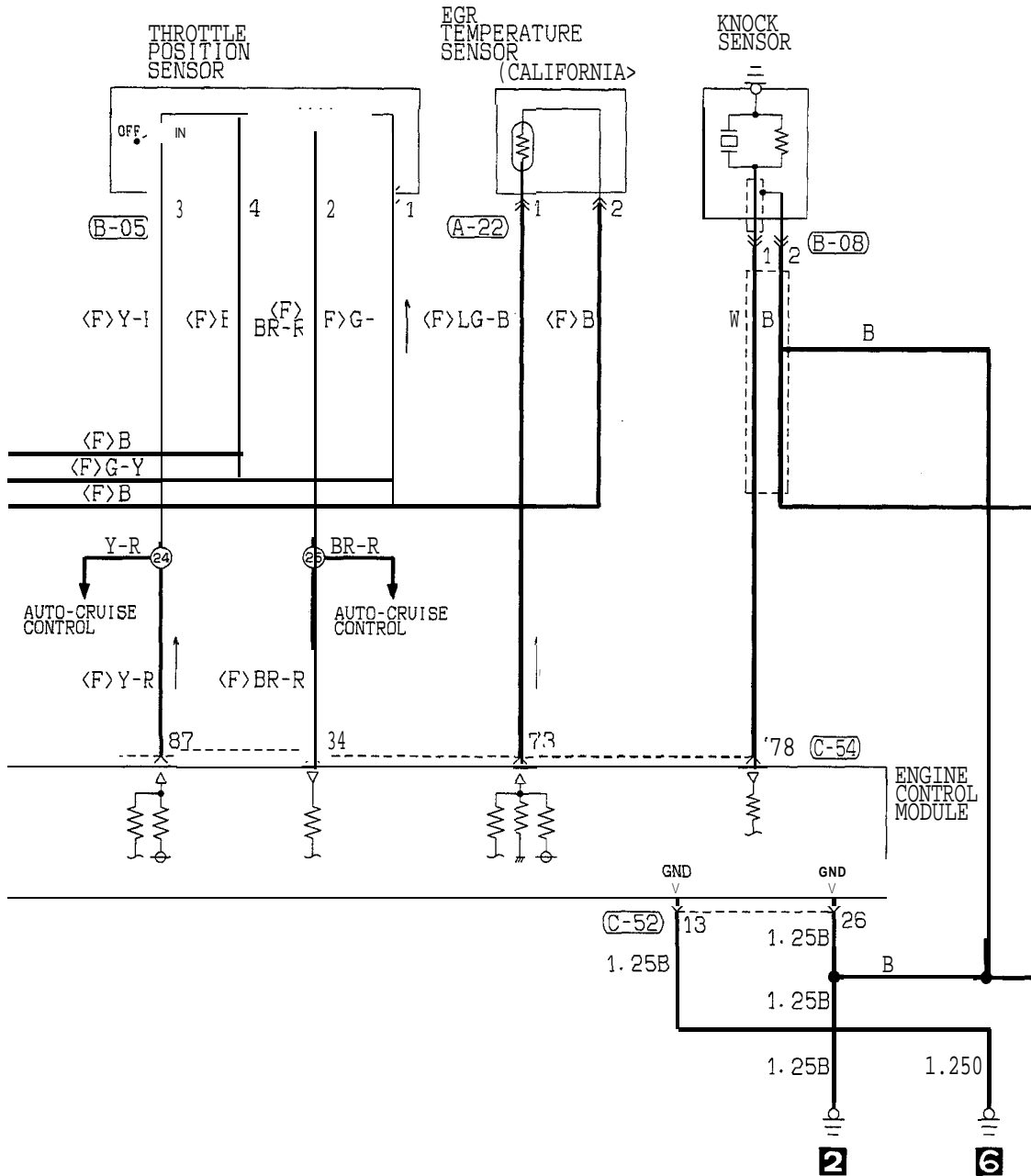

MFI CIRCUIT (1995 MODELS) <TURBO> (CONTINUED)

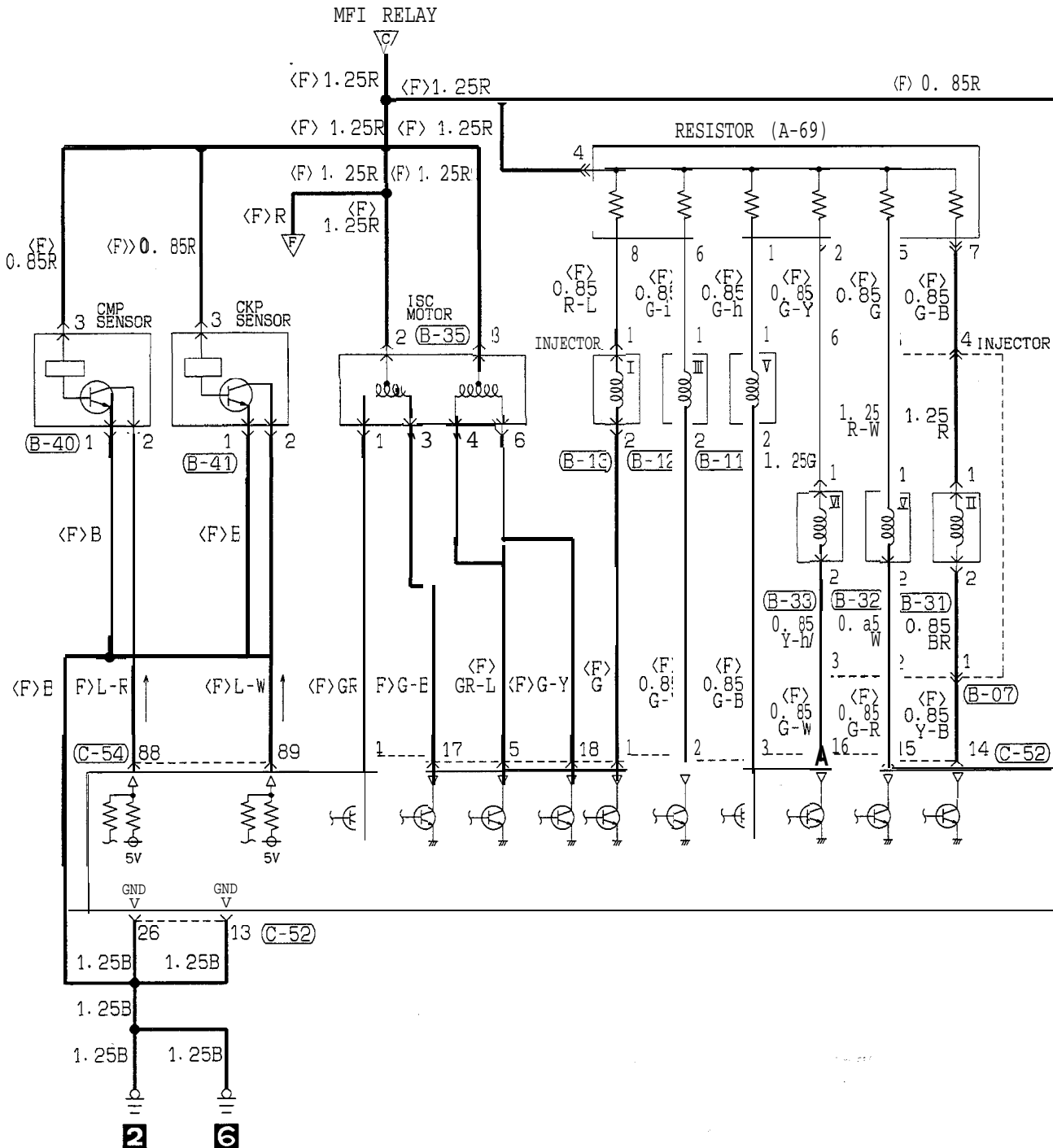

A-69	B-07	B-11	B-12	B-13	B-31	B-32	B-33	B-35	B-40	B-41
1 2 3 4 5 6 7 8	1 2 3 4 5 6	1 2	1 2	1 2	1 2	1 2	1 2 3 4 5 6	1 2 3 4 5 6	1 2 3 4 5 6	1 2 3
C-52	C-54									
1 2 3 4 5 6 7 8 9 10 11 12 13 14 15 16 17 18 19 20 21 22 23 24 25 26	71 72 73 74 75 76 77 78 79 80 81 82 83 84 85 86 87 88 89 90 91 92									

HR05M08CA

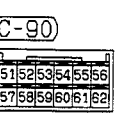
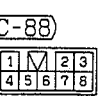
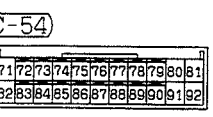
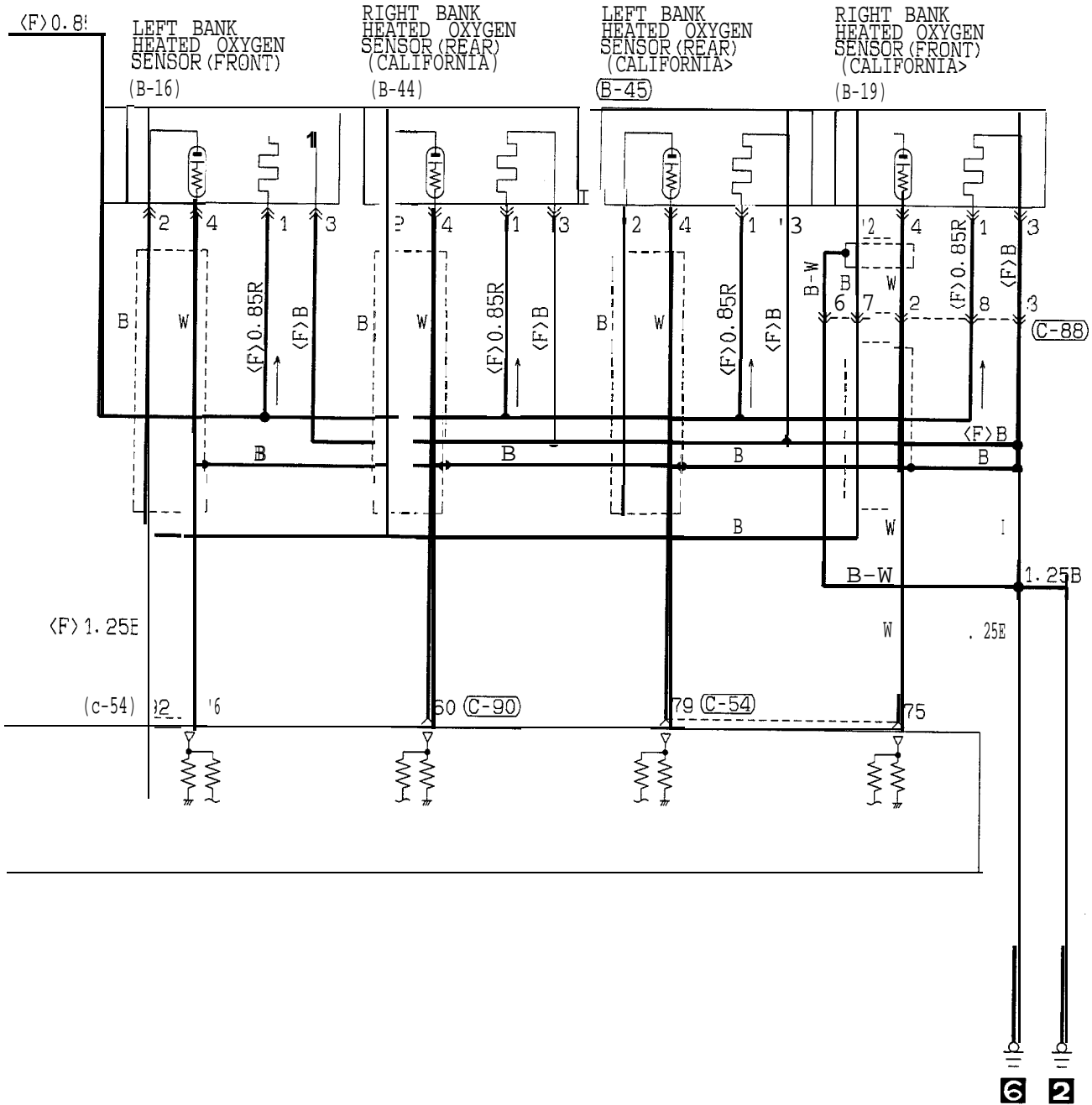



MFI CIRCUIT (1995 MODELS) <TURBO> (CONTINUED)

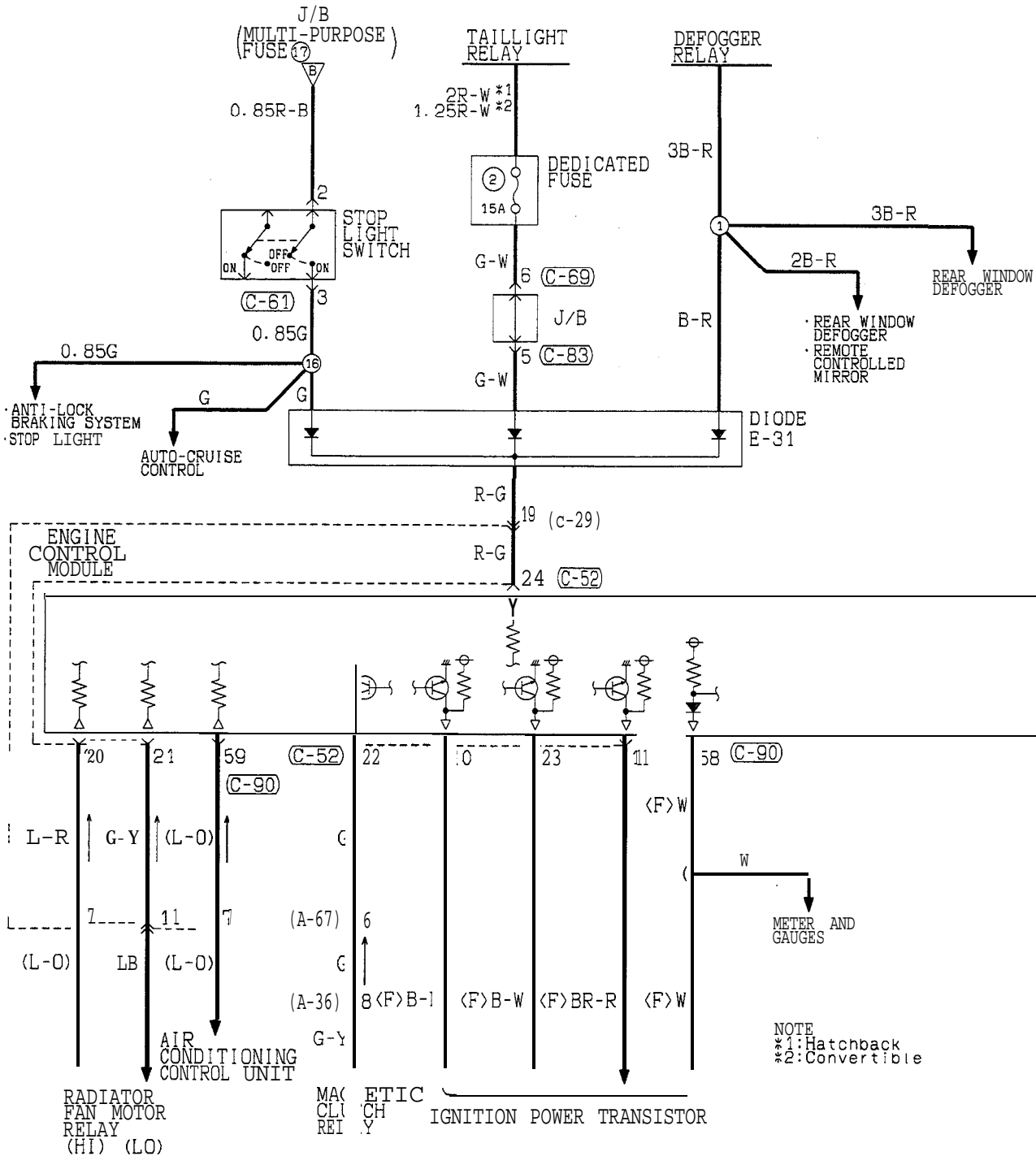

NOTE  
 \*1: Hatchback  
 \*2: Convertible

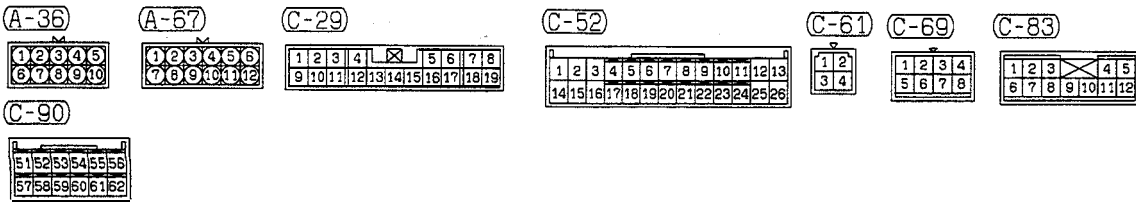

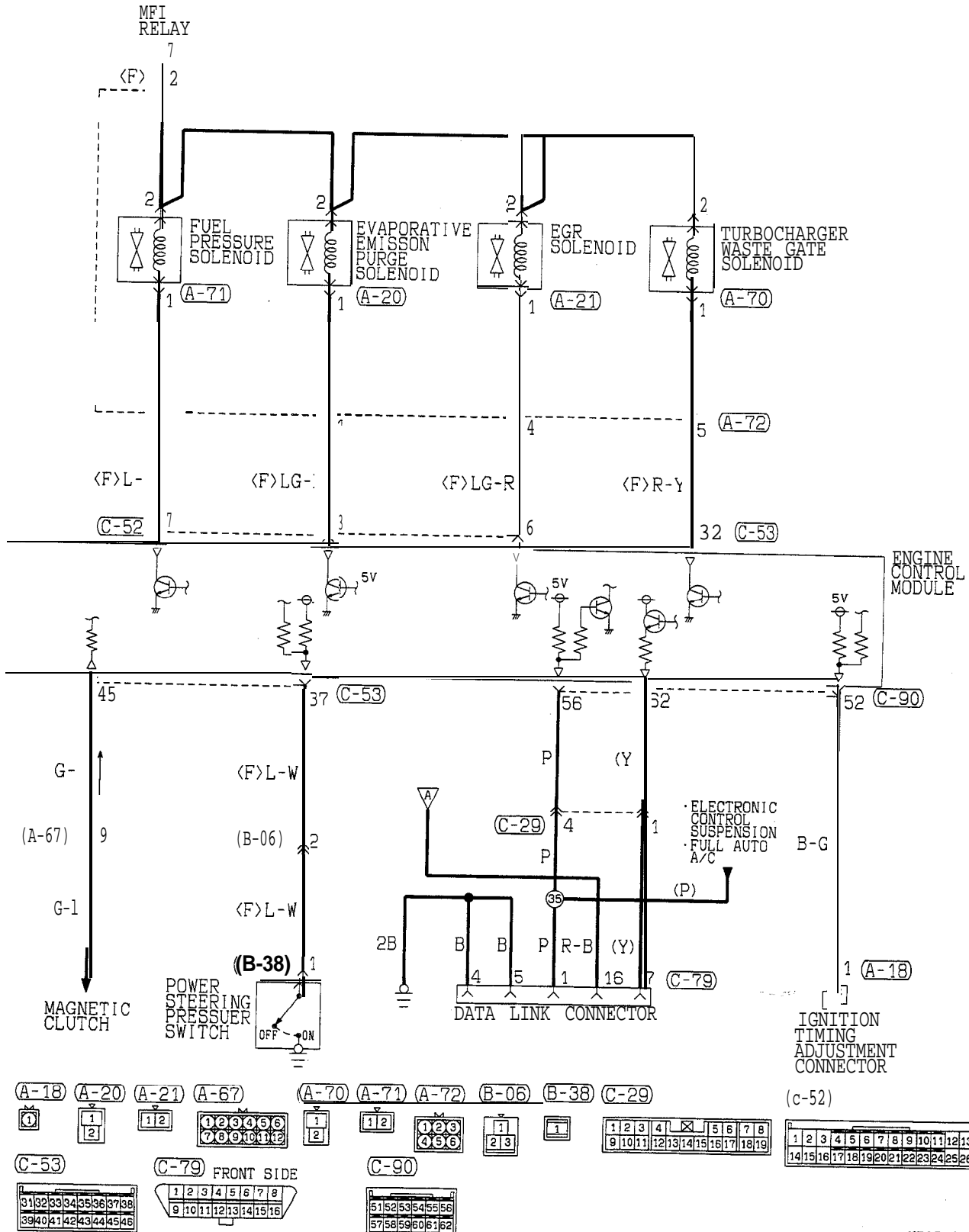

MFI CIRCUIT (FROM 1996 MODELS)

<NON TURBO>

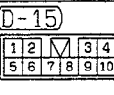
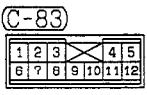
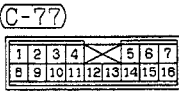
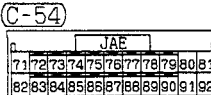
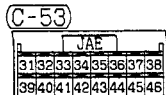
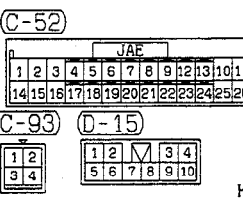
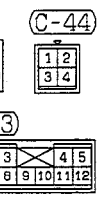
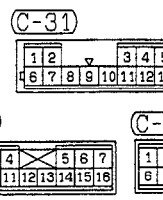
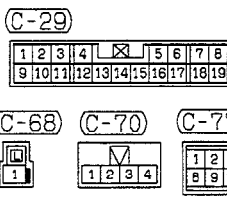
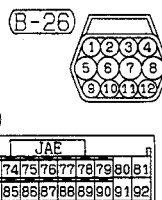
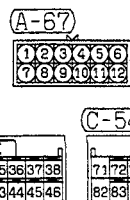
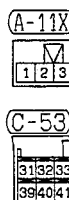
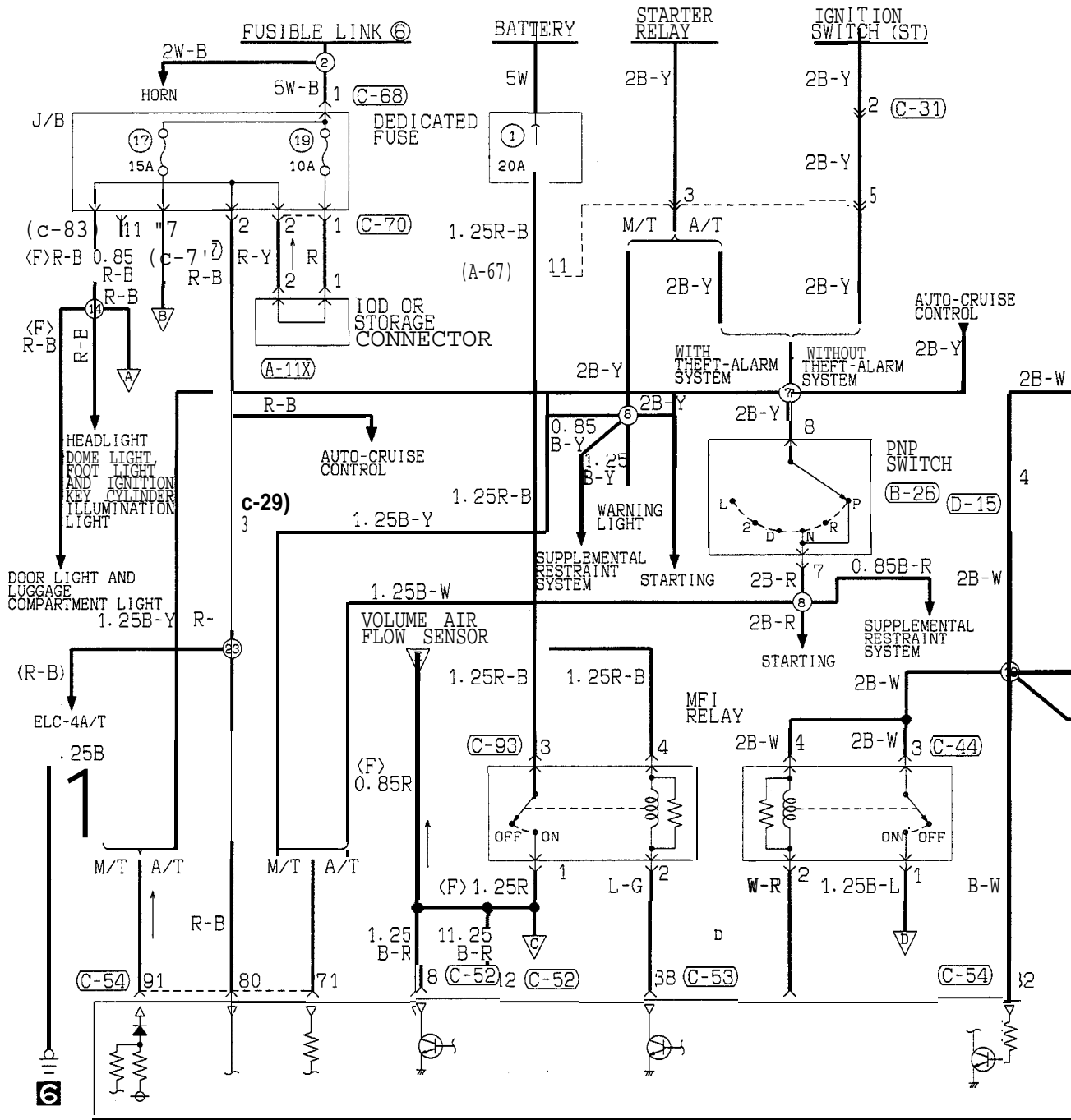



MFI CIRCUIT (FROM 1996 MODELS) <NON TURBO> (CONTINUED)

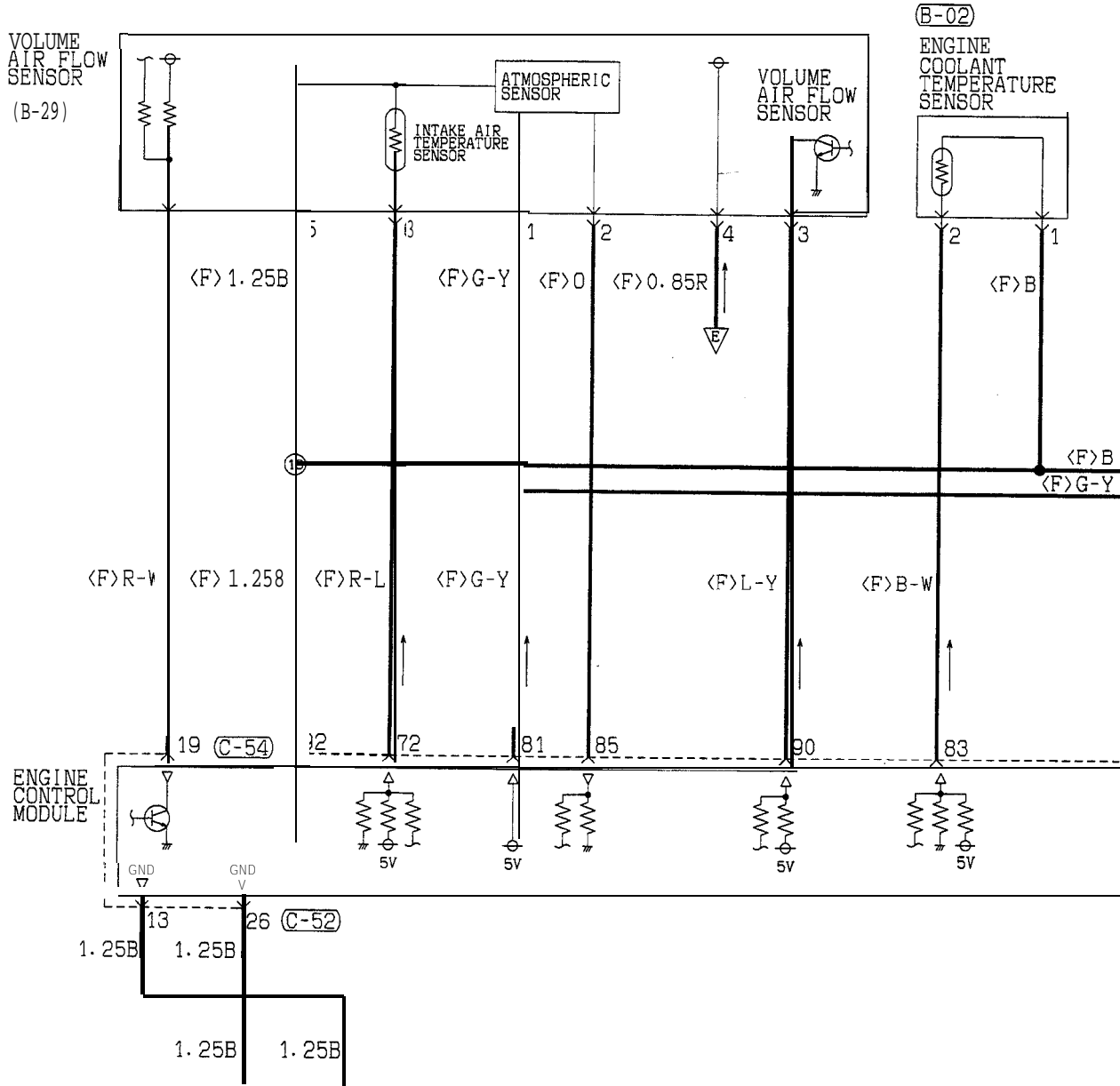

**2 6**

(B-02)

(B-29)

(C-52)

(C-54)

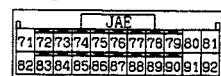
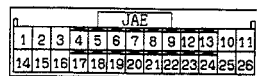

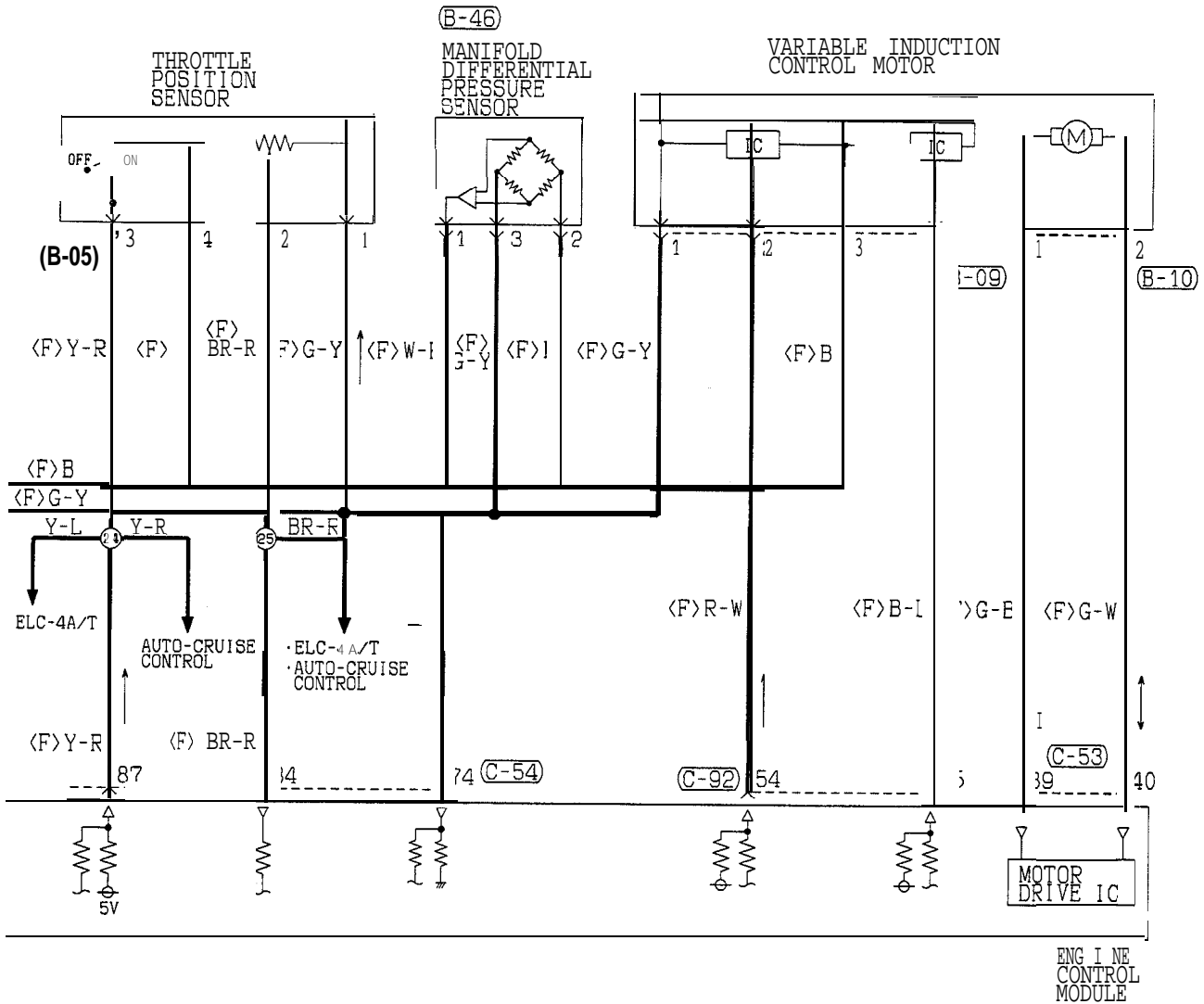

(B-05)

1	2	3	4
---	---	---	---

(B-09)

1	2	3	4
---	---	---	---

(B-10)

1	2
---	---

(B-46)

1	2	3
---	---	---

(C-53)

JAE							
31	32	33	34	35	36	37	38
39	40	41	42	43	44	45	46

(C-54)

JAE											
71	72	73	74	75	76	77	78	79	80	81	
82	83	84	85	86	87	88	89	90	91	92	

(C-92)

JAE					
51	52	53	54	55	56
57	58	59	60	61	62

ENG I NE  
CONTROL  
MODULE

MFI CIRCUIT (FROM 1996 MODELS) <NON TURBO> (CONTINUED)

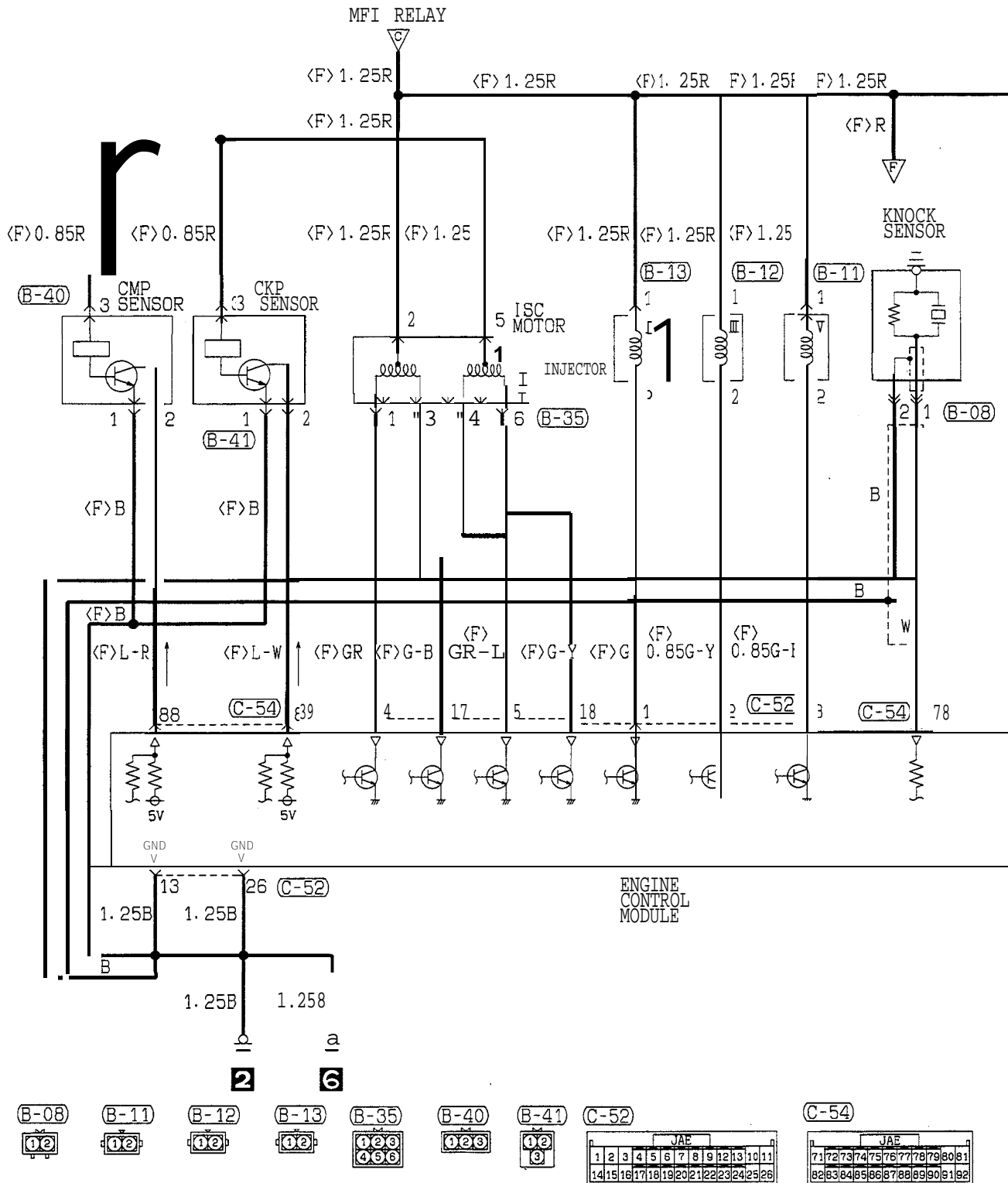

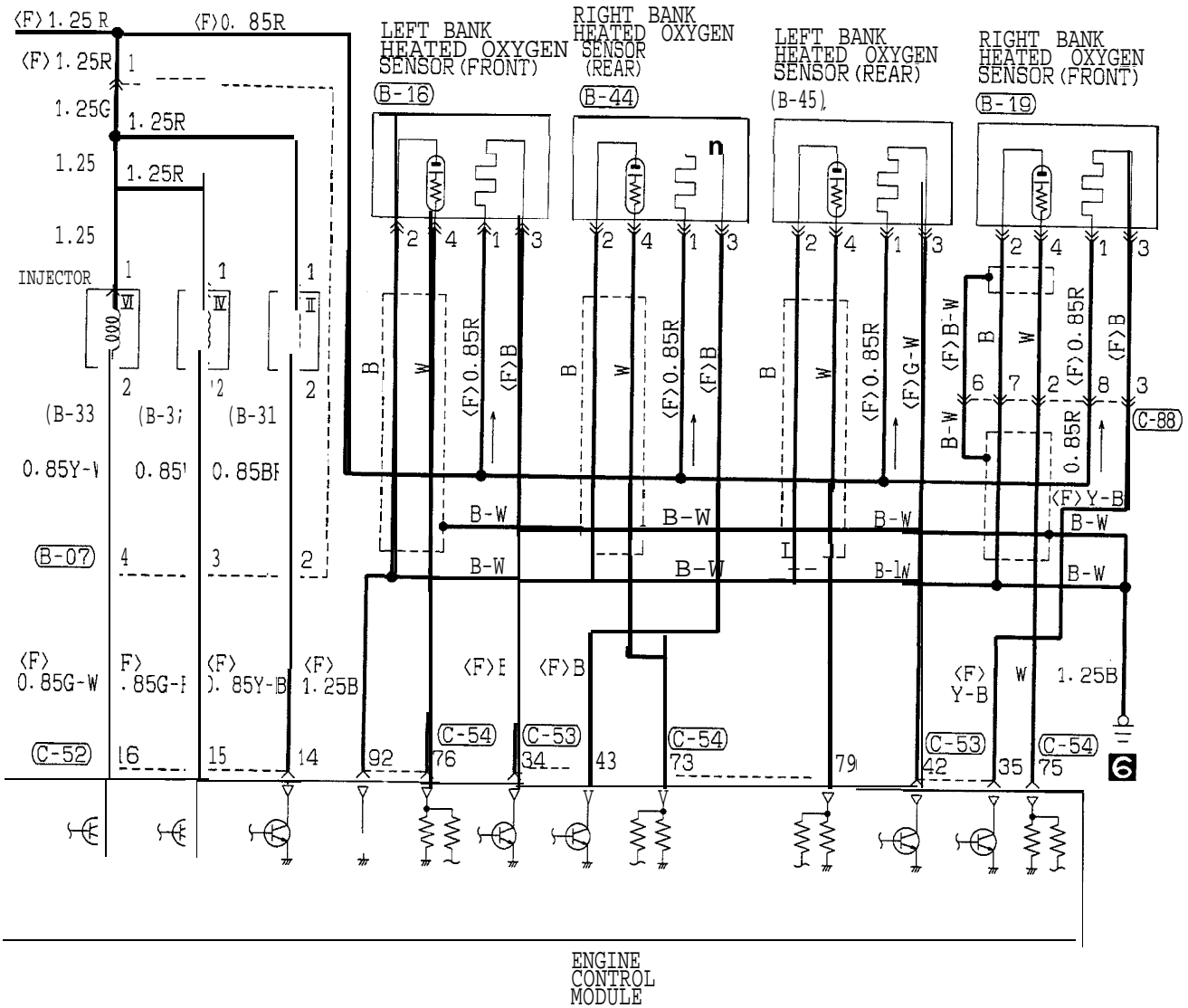

ENGINE CONTROL MODULE

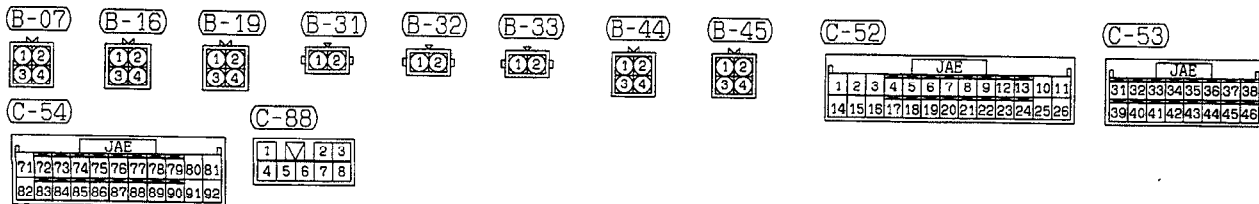

HR05M09CB

TSB Revision



MFI CIRCUIT (FROM 1996 MODELS) <NON TURBO> (CONTINUED)

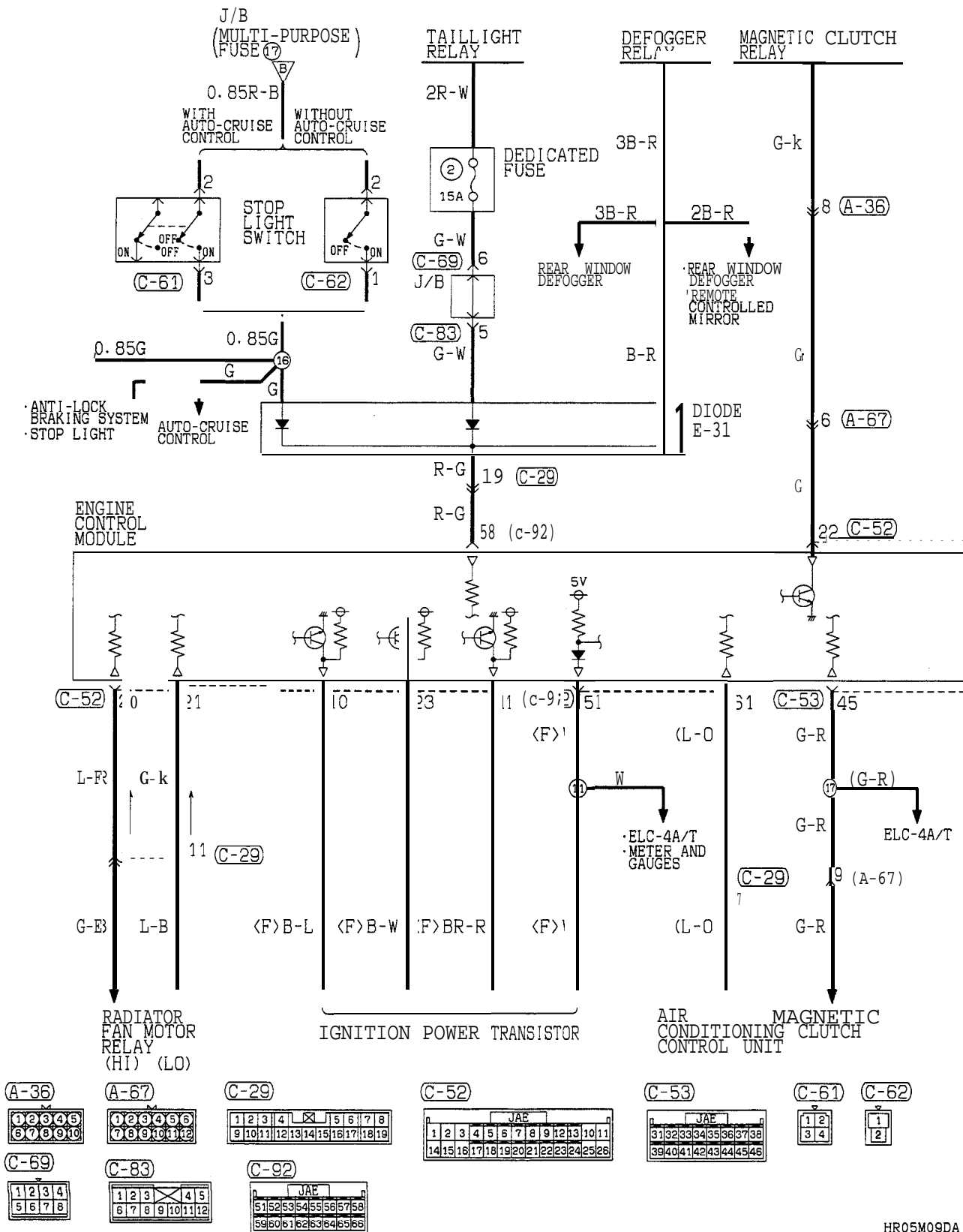

TSB Revision

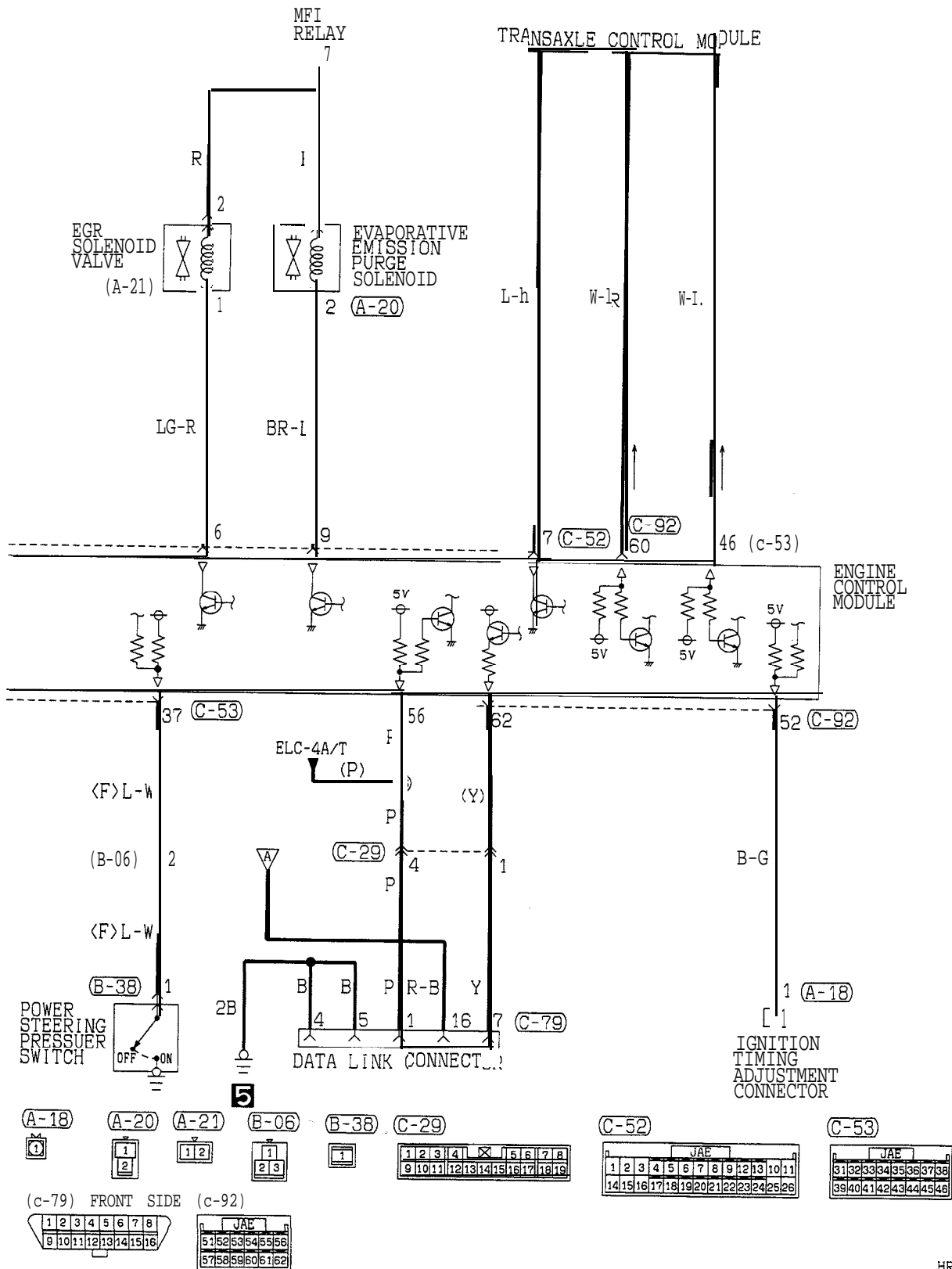

MFI CIRCUIT (FROM 1996 MODELS)

<TURBO>

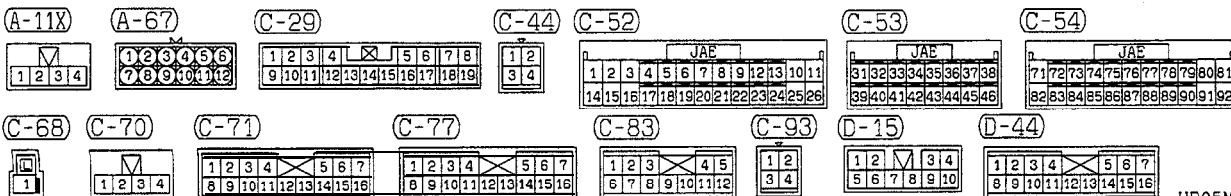
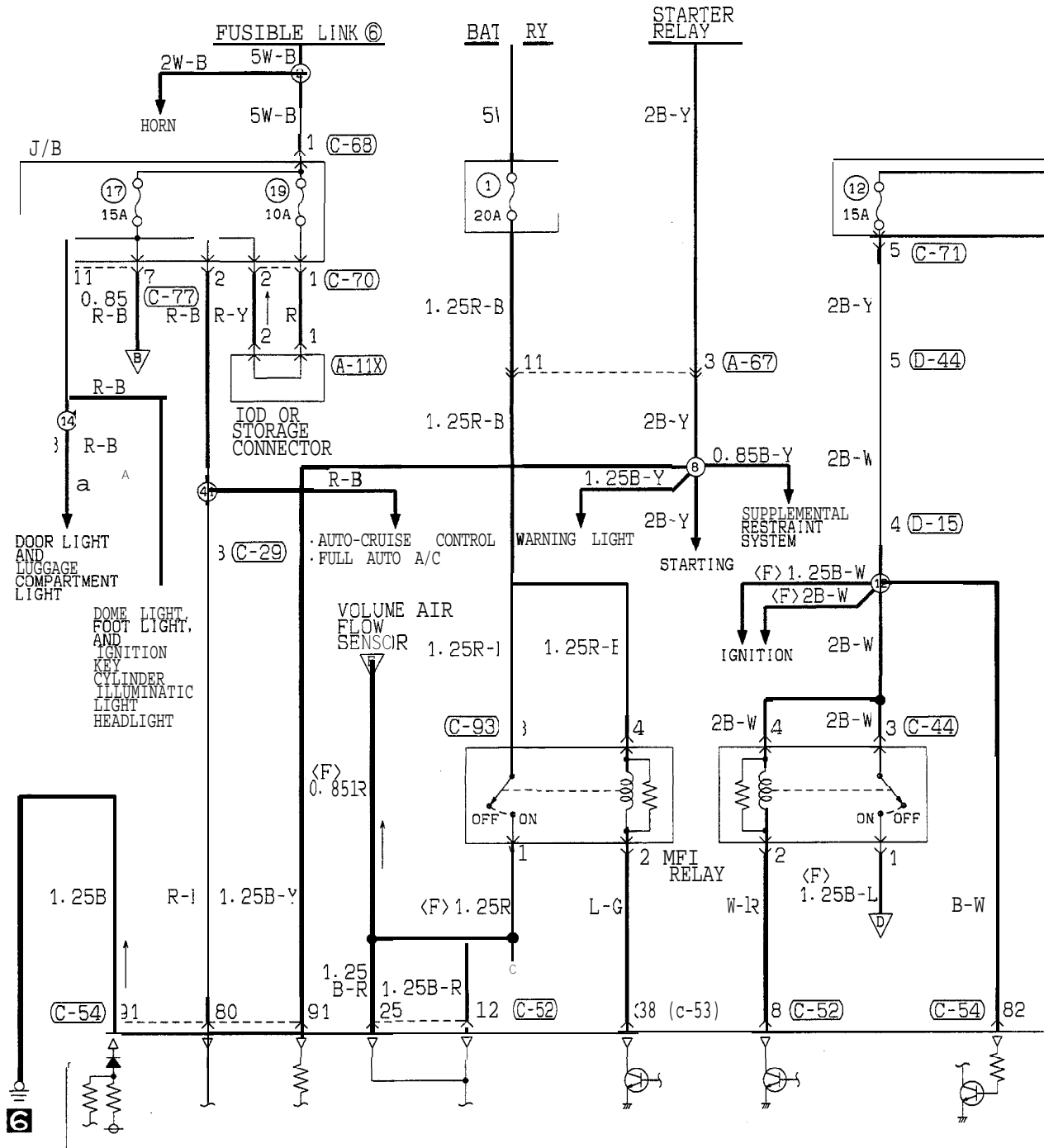

HR05M10AA

TSB Revision

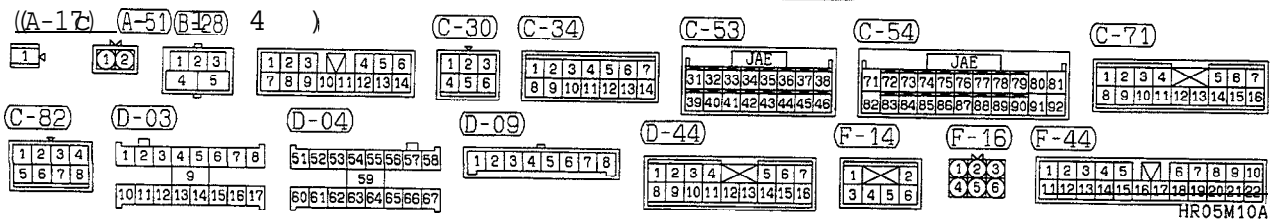
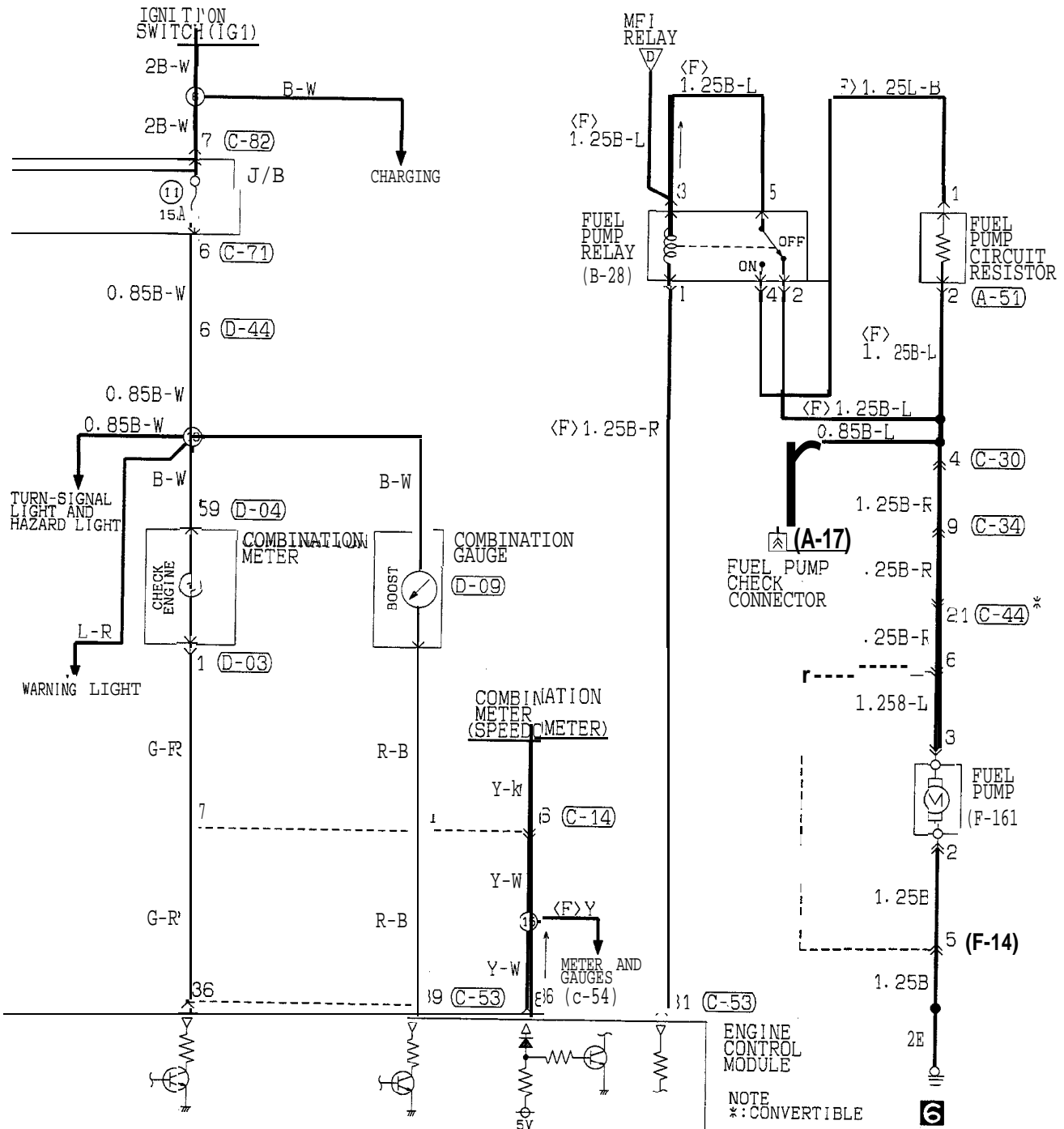

TSB Revision

MFI CIRCUIT (FROM 1996 MODELS) <TURBO> (CONTINUED)

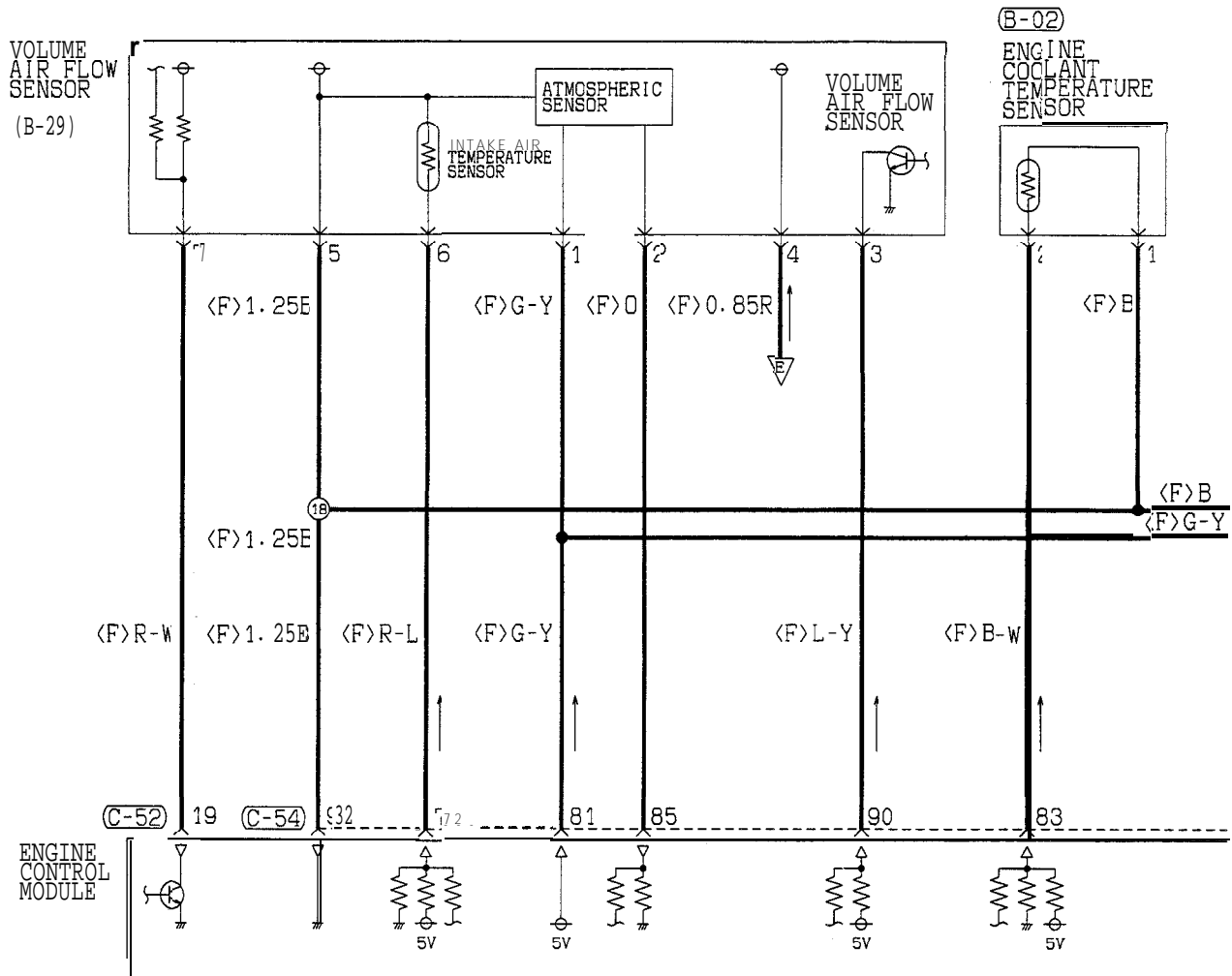

(B-02)

(B-29)

(C-52)

(C-54)

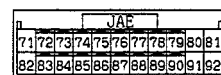
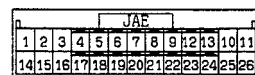

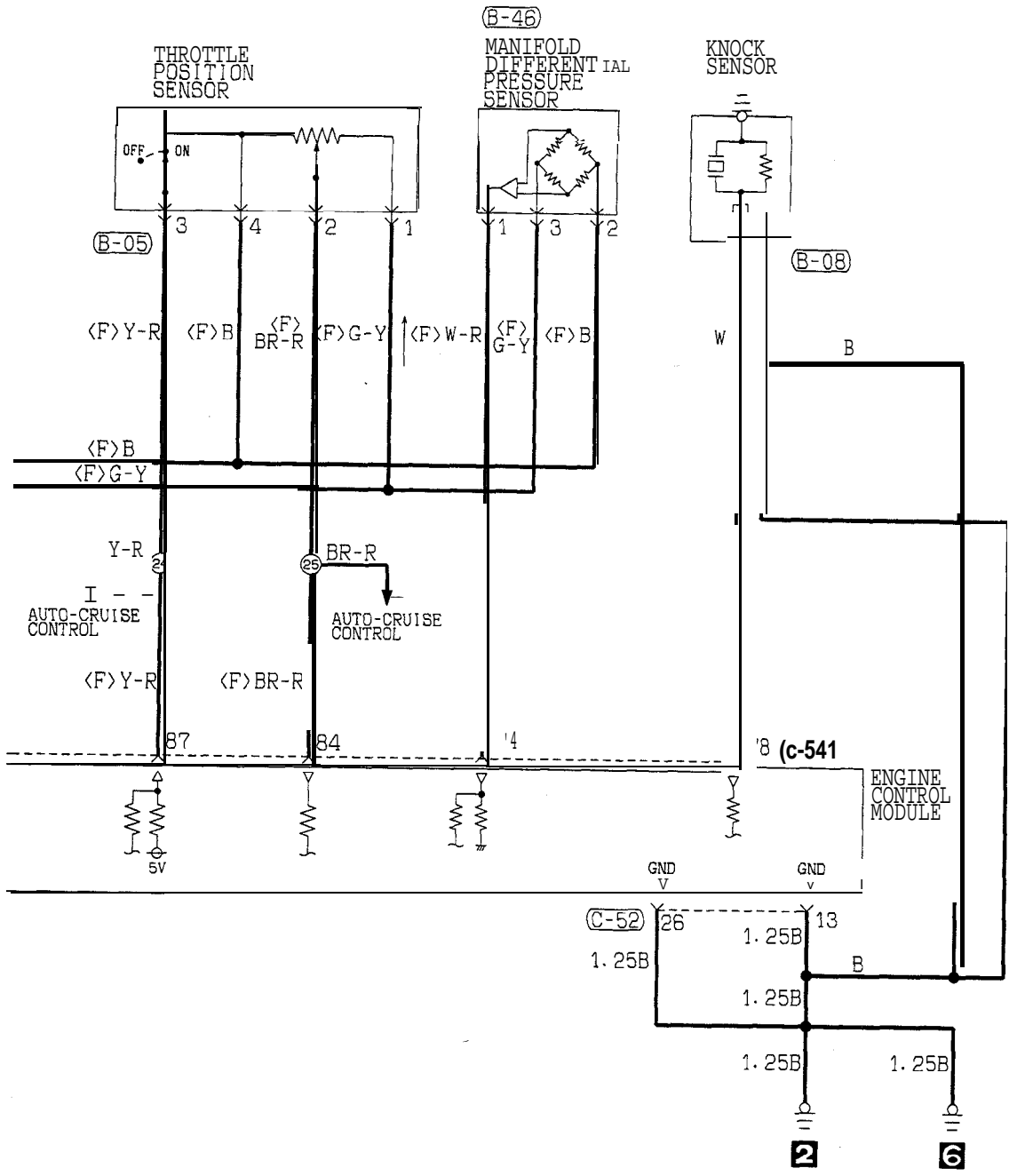

(A-22) (B-05) (B-08) (B-46) (c-52)



JAE												
1	2	3	4	5	6	7	8	9	12	13	10	11
14	15	16	17	18	19	20	21	22	23	24	25	26

(C-54)

JAE											
71	72	73	74	75	76	77	78	79	80	81	
82	83	84	85	86	87	88	89	90	91	92	

TSB Revision

MFI CIRCUIT (FROM 1996 MODELS) <TURBO> (CONTINUED)

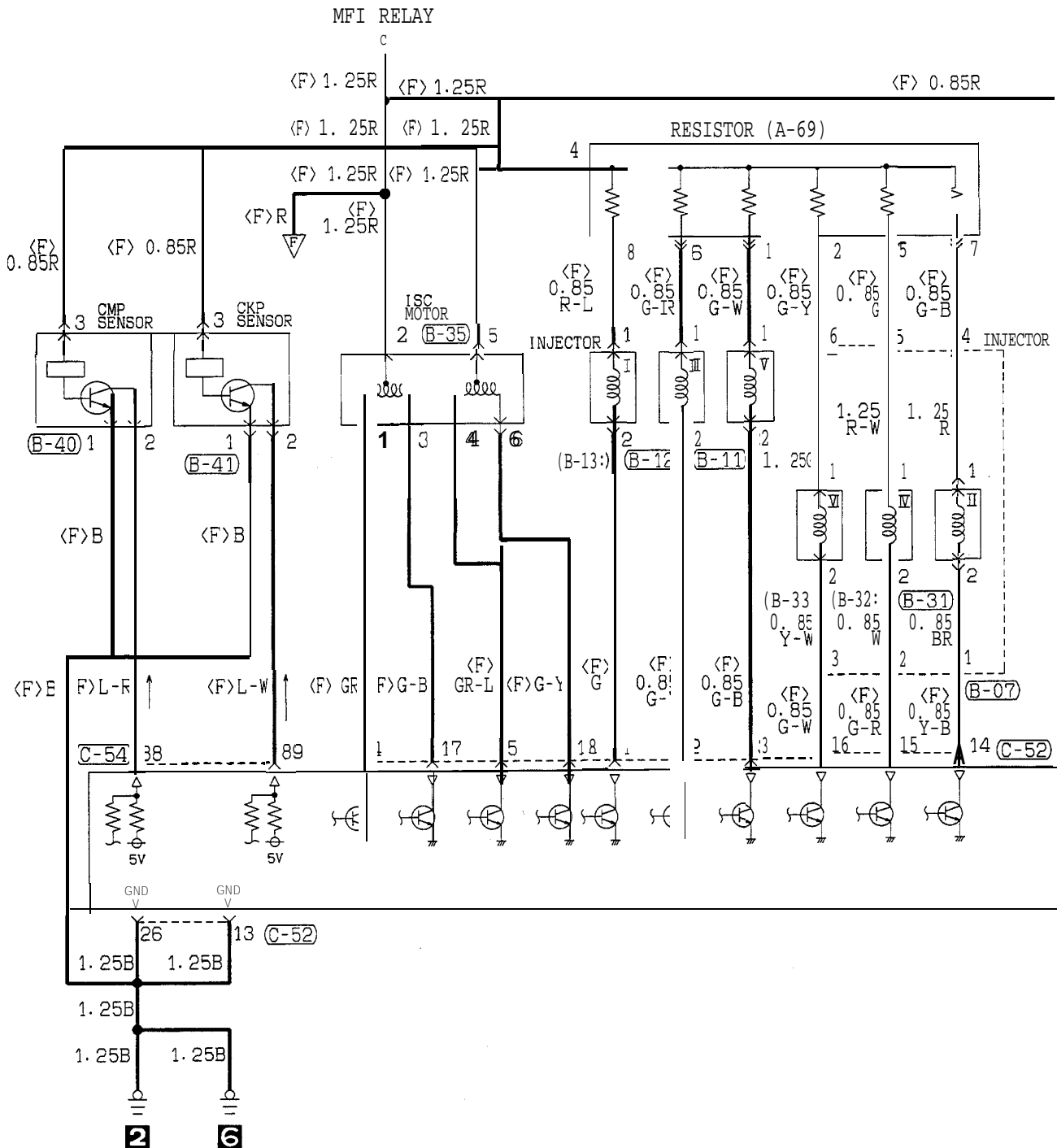

A-69	B-07	B-11	B-12	B-13	B-31	B-32	B-33	B-35	B-40	B-41	C-52
C-54											

TSB Revision

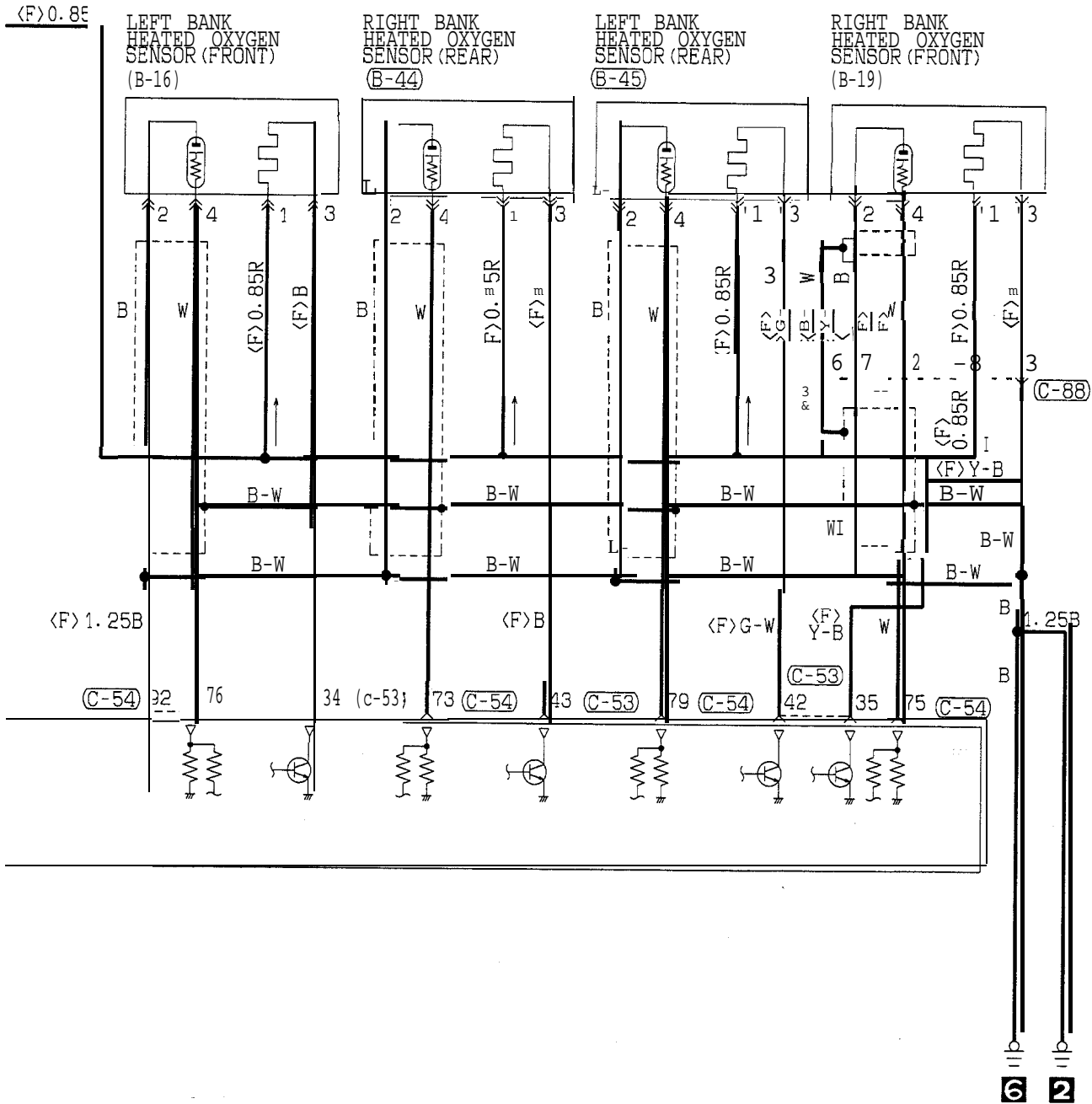

B-16

1	2
3	4

B-19

1	2
3	4

B-44

1	2
3	4

B-45

1	2
3	4

C-53

JAE							
31	32	33	34	35	36	37	38
39	40	41	42	43	44	45	46

C-54

JAE											
71	72	73	74	75	76	77	78	79	80	81	
82	83	84	85	86	87	88	89	90	91	92	

C-88

1	2	3		
4	5	6	7	8



MFI CIRCUIT (FROM 1996 MODELS) <TURBO> (CONTINUED)

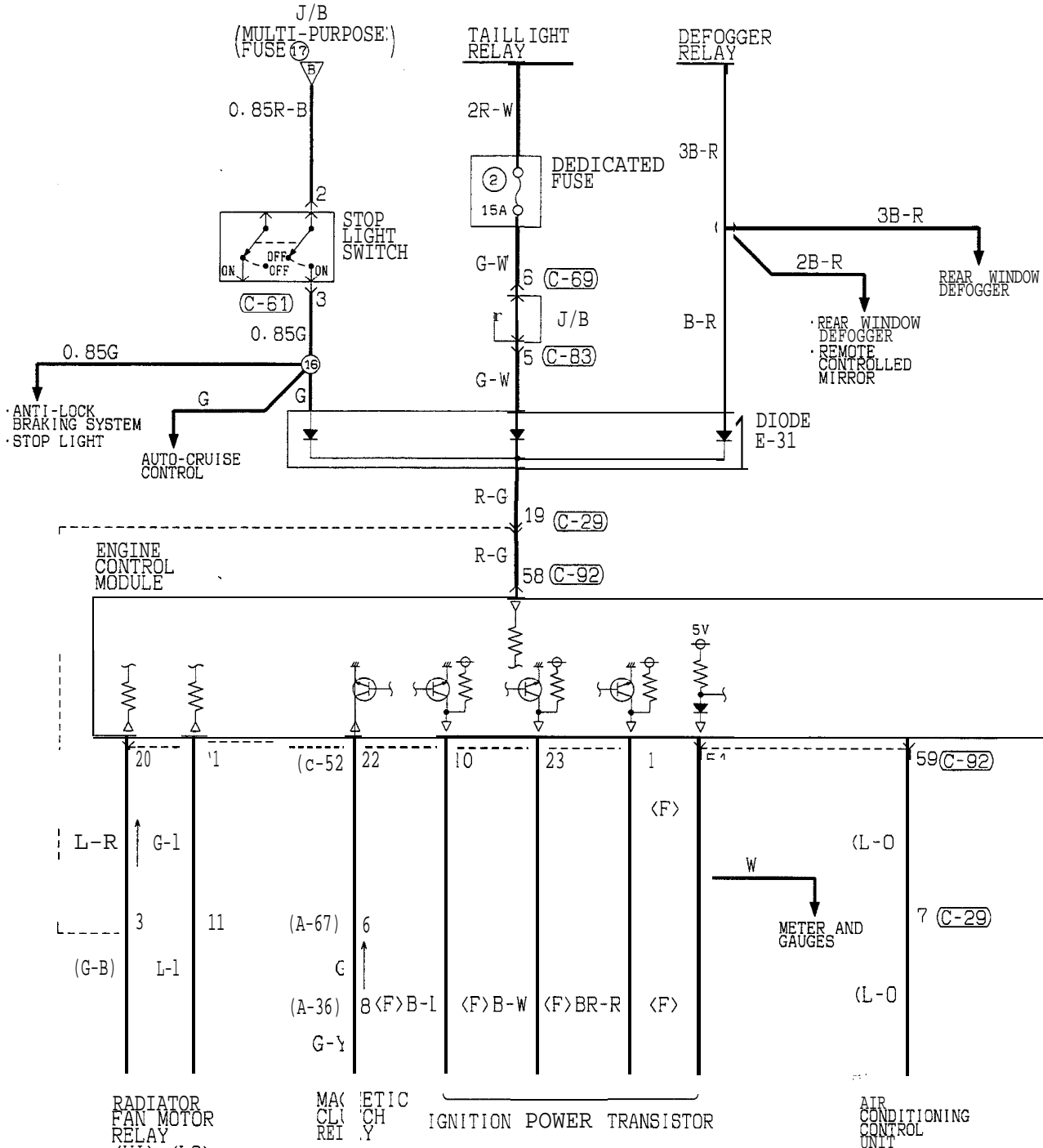

(A-36)



(A-67)



(C-29)

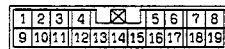

(C-52)

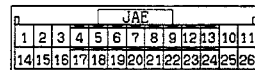

(C-61)



(C-69)



(C-83)

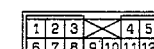

(C-92)

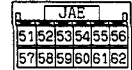

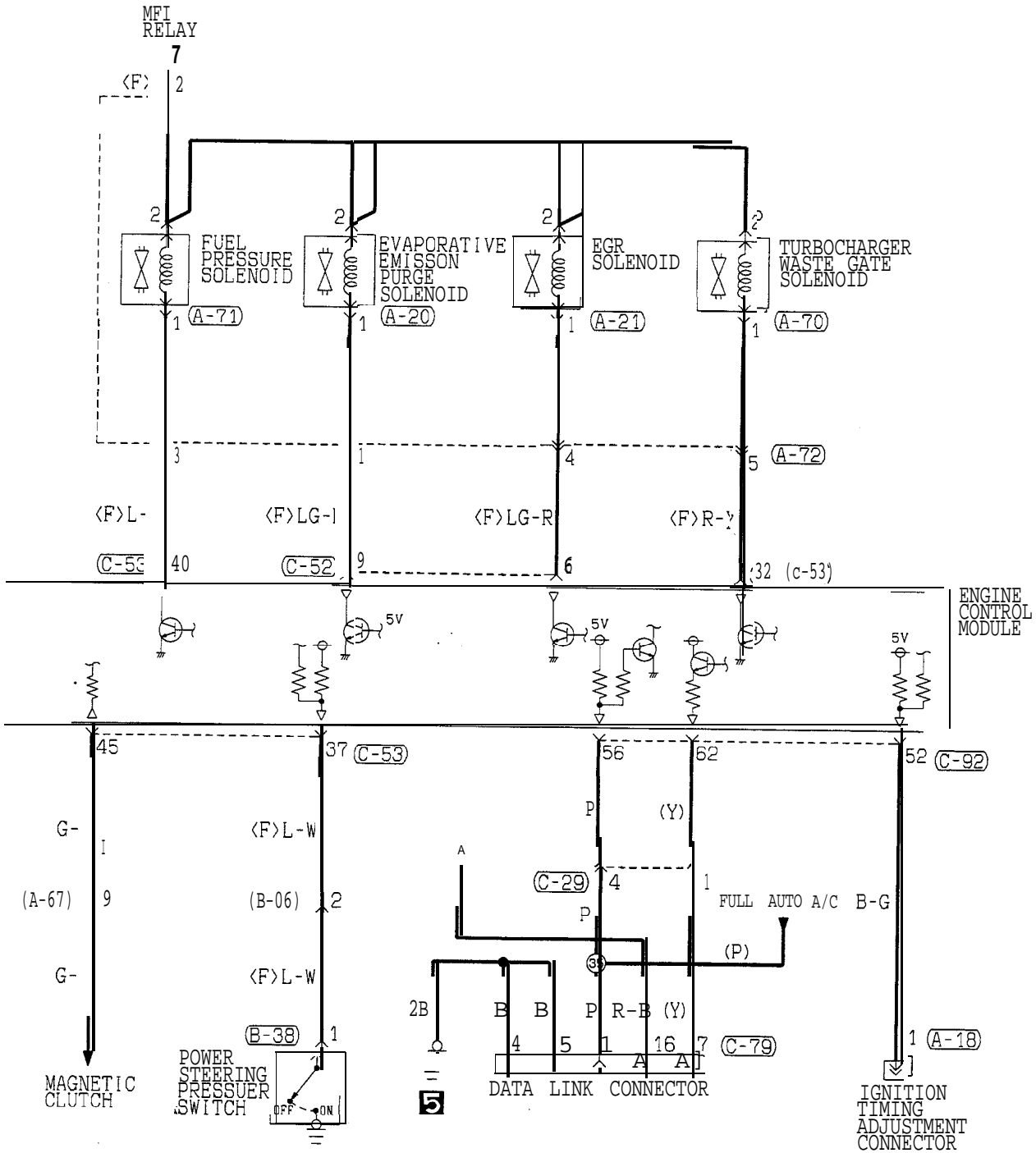

(A-18)	(A-20)	(A-21)	(A-67)	(A-70)	(A-71)	(A-72)	(B-06)	(B-38)	(C-29)	(C-52)
1	1	1	1 2 3 4 5 6 7 8 9 10 11 12	1	1	1 2 3 4 5 6	1	1	1 2 3 4 5 6 7 8 9 10 11 12 13 14 15 16 17 18 19	1 2 3 4 5 6 7 8 9 10 11 12 13 14 15 16 17 18 19 20 21 22 23 24 25 26
(C-54)	(C-79) FRONT SIDE	(C-92)								
1 2 3 33 34 35 36 37 38 39 40 41 42 43 44 45 46	1 2 3 4 5 6 7 8 9 10 11 12 13 14 15 16	1 2 3 4 5 6 7 8 9 10 11 12 13 14 15 16 17 18 19 20 21 22 23 24 25 26								

TSB Revision

**COMPONENT LOCATION**

Up to 1993 models and 1994, 1995 models Non Turbo (Federal)

Name	Symbol	Name	Symbol
Air conditioning relay	O	Ignition coil (ignition power transistor)	M
Air conditioning switch	G	Ignition timing adjusting terminal	Q
Camshaft position sensor	a	Injector	K
Check engine/malfunction indicator lamp	P	Knock sensor	T
Crankshaft position sensor	D	<b>Multiport fuel injection (MFI) relay</b>	N
Data link connector	R	Data link connector	R
EGR solenoid <California – Non Turbo, Turbo>	Z	Park/Neutral position switch <A/T>	I
EGR temperature sensor <California – Non Turbo, Turbo>	Y	Power steering pressure switch	H
Engine control module	S	Resistor <Turbo>	W
Engine coolant temperature sensor	B	Throttle position sensor (With built-in closed throttle position switch)	C
Evaporative emission purge solenoid	X	Turbocharger waste gate solenoid <Turbo>	U
Fuel pressure solenoid <Turbo>	V	Variable induction control motor (DC motor) (with built-in induction control valve position sensor) <Non Turbo>	J
Heated oxygen sensor	E	Vehicle speed sensor	F
Idle air control motor (stepper motor)	L	Volume air flow sensor (with built-in intake air temperature sensor and barometric pressure sensor)	A



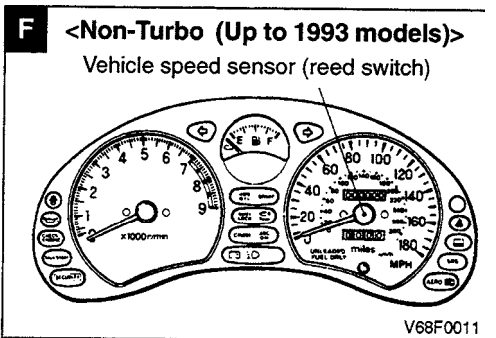
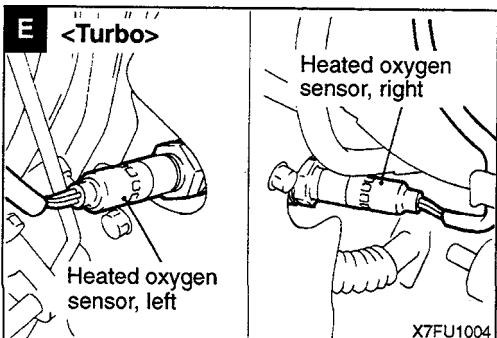
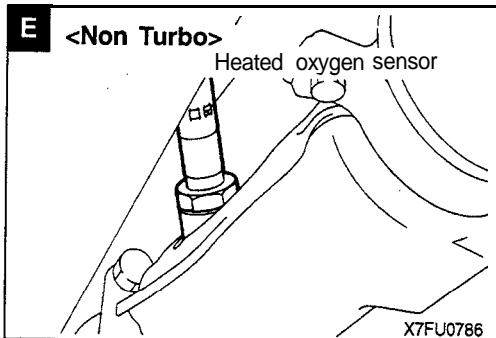
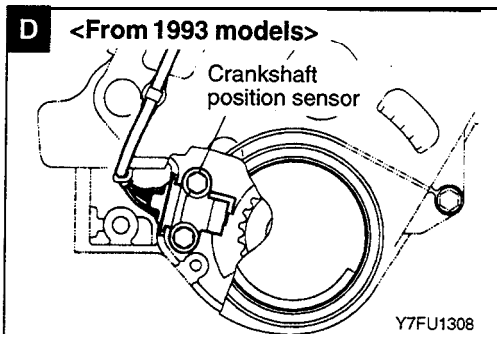
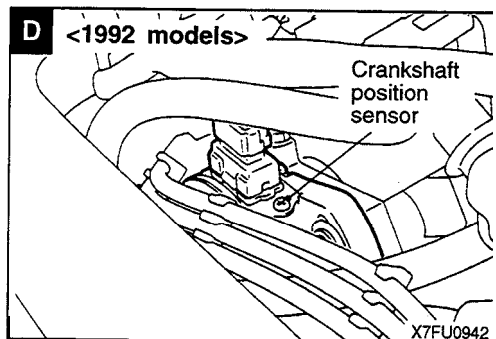
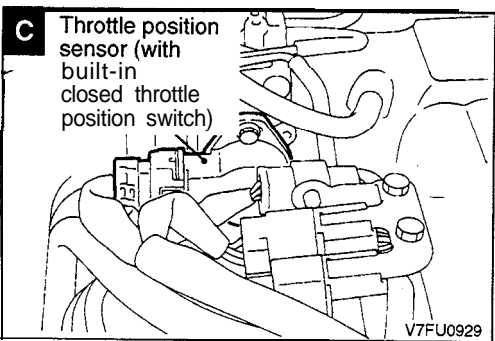
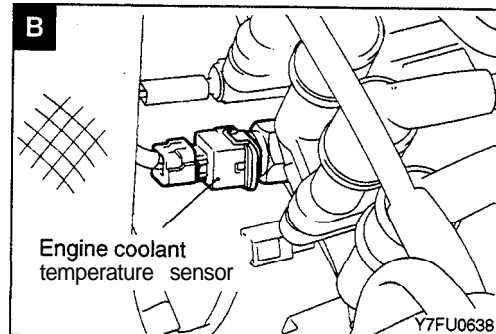
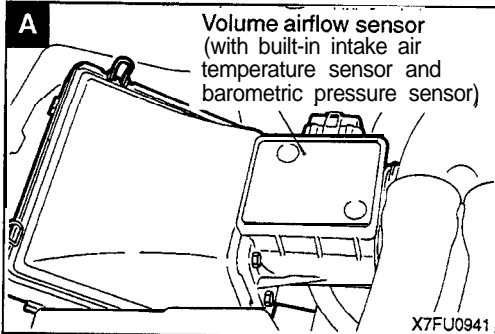
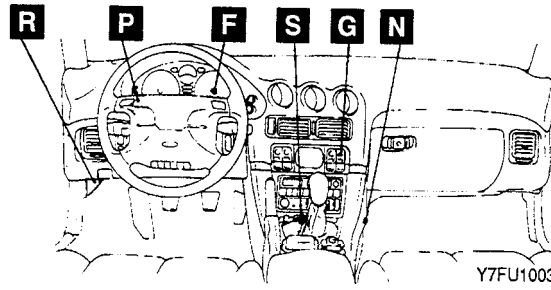

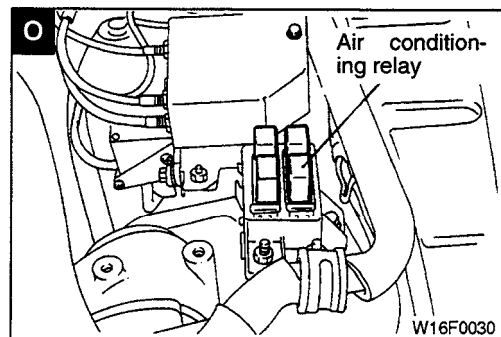
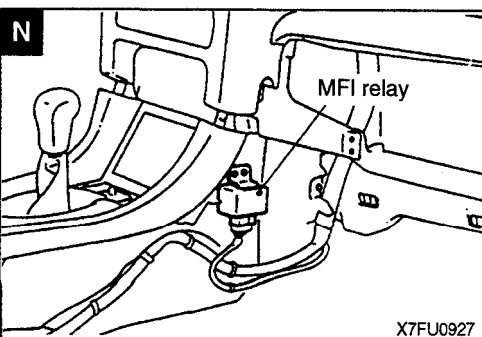
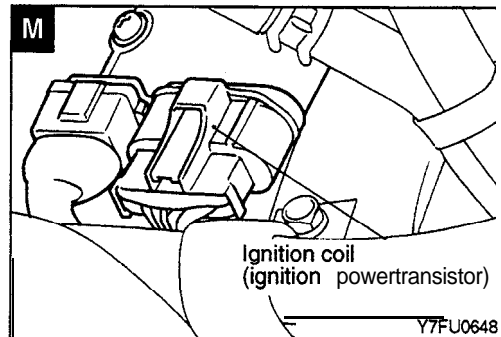
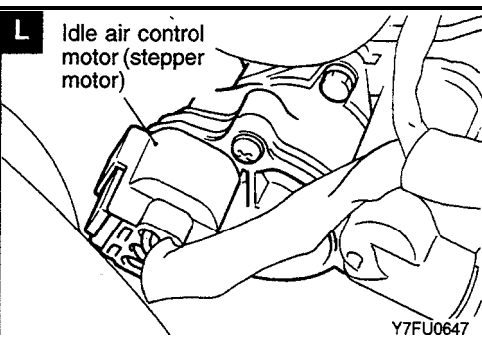
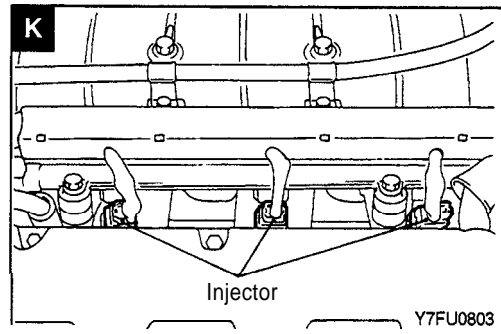
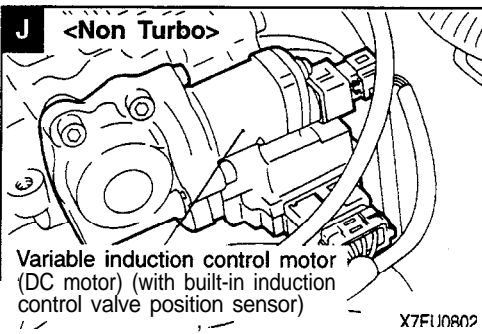
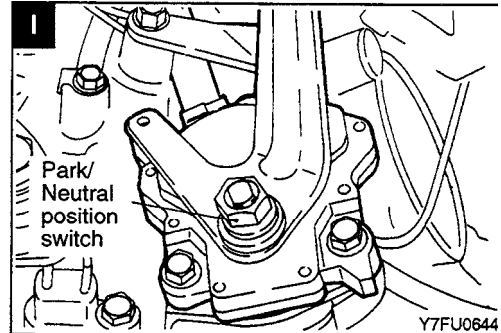
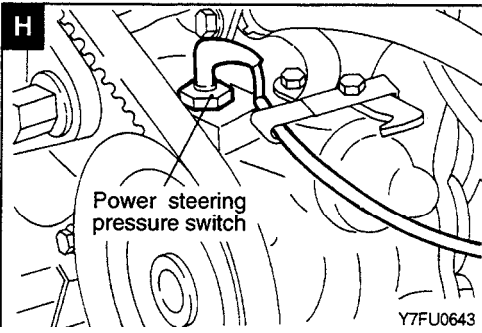
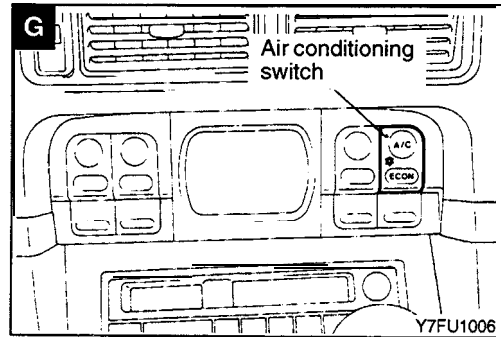
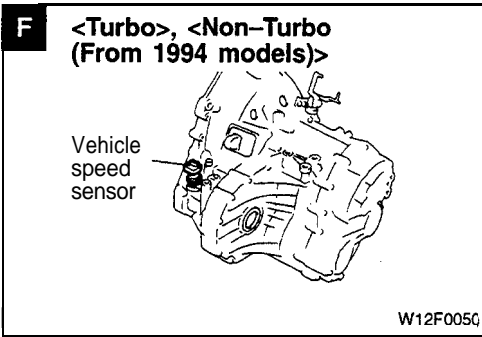

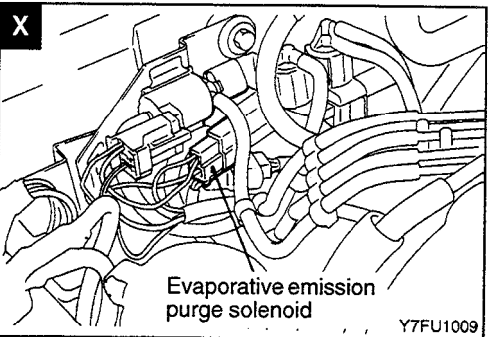
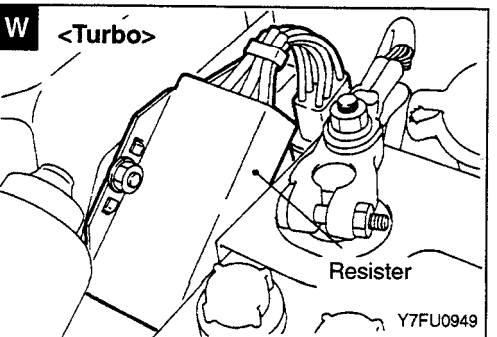
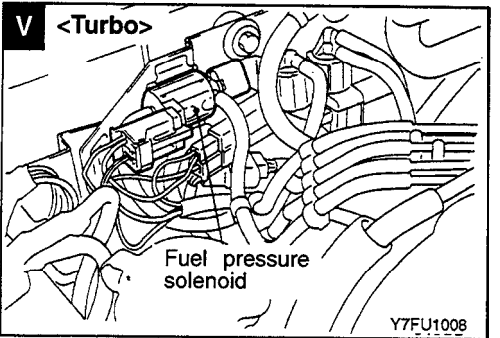
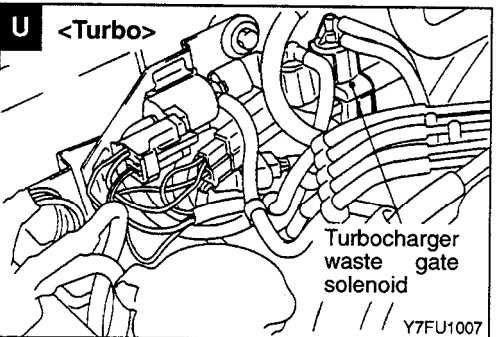
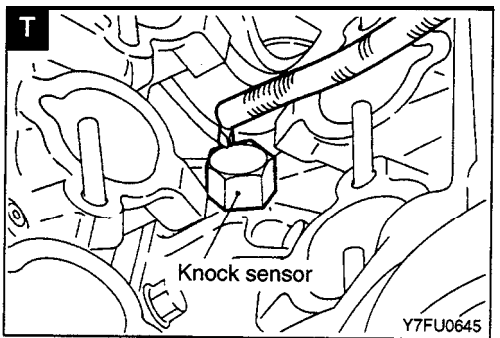
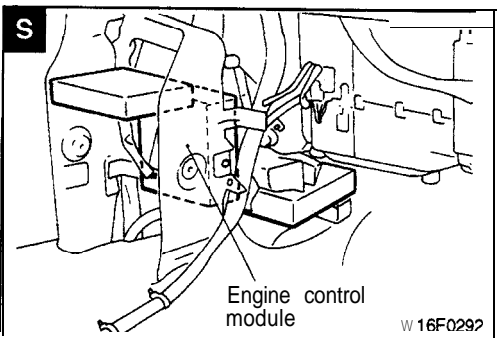
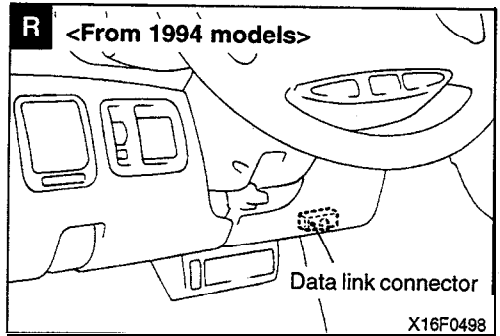
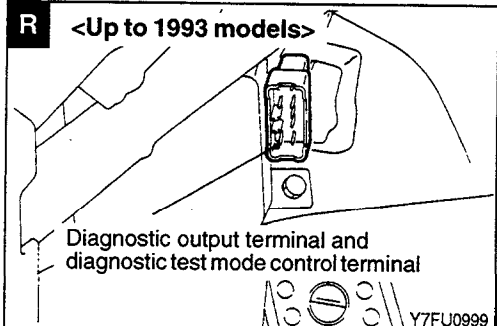
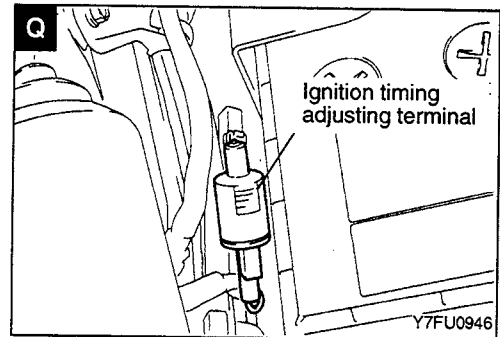
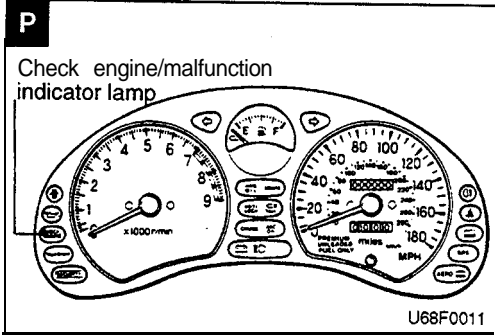

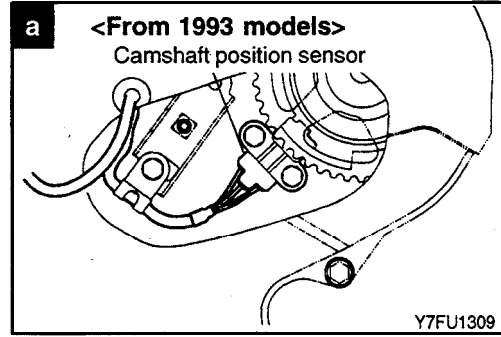
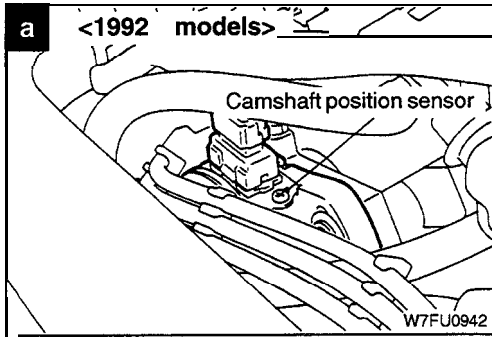
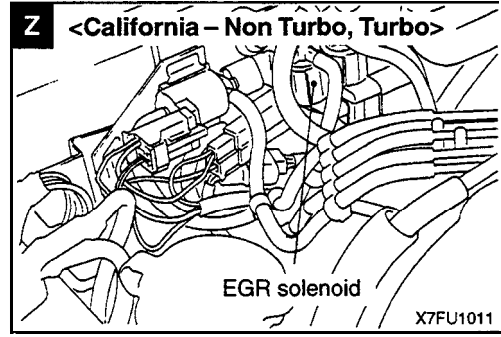
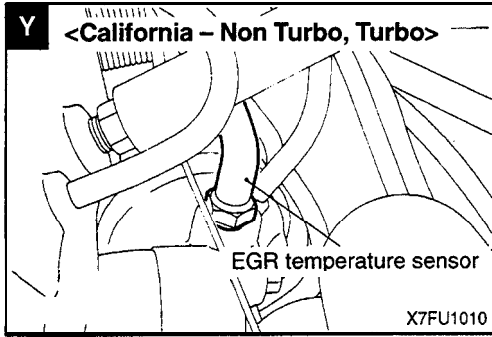

1994, 1995 models except Non Turbo (Federal) and from 1996 models

Name	Symbol	Name	Symbol
Air conditioning relay	O	Ignition timing adjusting terminal	Q
Air conditioning switch	G	Injector	K
Camshaft position sensor	a	Knock sensor	T
Check engine/malfunction indicator lamp	P	Left bank heated oxygen sensor	E
Crankshaft position sensor	D	Manifold differential pressure sensor (From 1996 models)	Y
Data link connector	R	Multiport fuel injection (MFI) relay	N
EGR solenoid <Up to 1995 models for California – Non Turbo, Turbo, 1996 models>	Z	Park/Neutral position switch <A/T>	I
EGR temperature sensor <Up to 1995 models for California, Up to 1995 models for Federal -Turbo>	Y	Power steering pressure switch	H
		Resistor <Turbo>	W
Engine control module	S	Right bank heated oxygen sensor	E
Engine coolant temperature sensor	B	Throttle position sensor (with built-in closed throttle position switch)	C
Evaporative emission purge solenoid	X	Turbocharger waste gate solenoid <Turbo>	U
Fuel pressure solenoid <Turbo>	V	Variable induction control motor (DC motor) (with built-in induction control valve position sensor) <Non Turbo>	J
Heated oxygen sensor	E		
Idle air control motor (stepper motor)	L	Vehicle speed sensor	F
Ignition coil (ignition power transistor)	M	Volume air flow sensor (with built-in intake air temperature sensor and barometric pressure sensor)	A

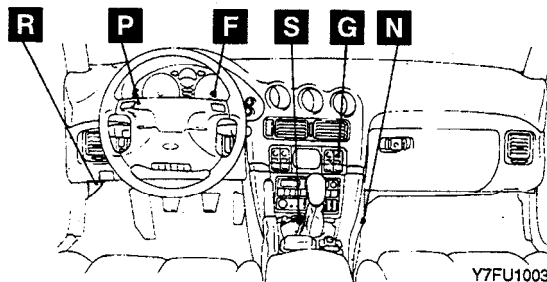
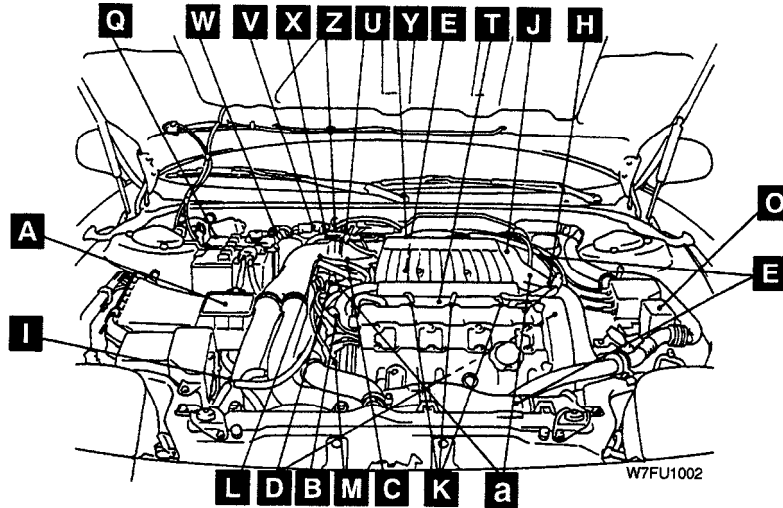



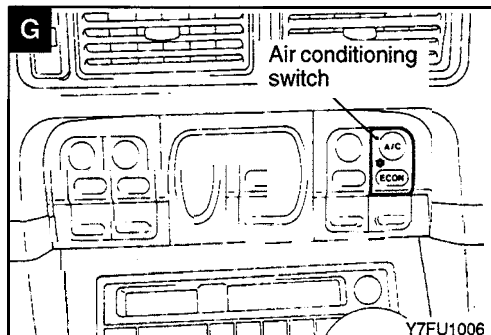
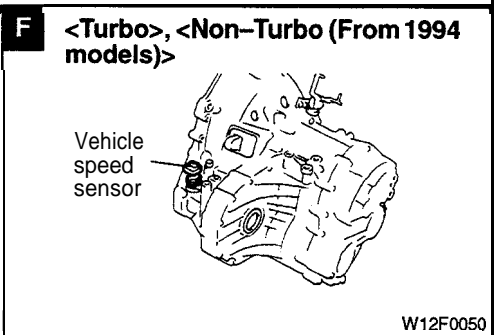
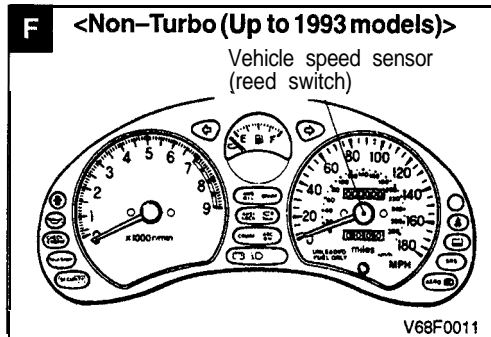
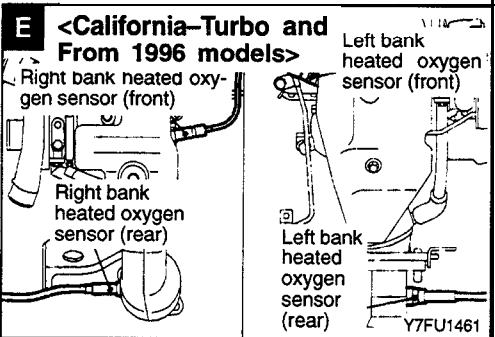
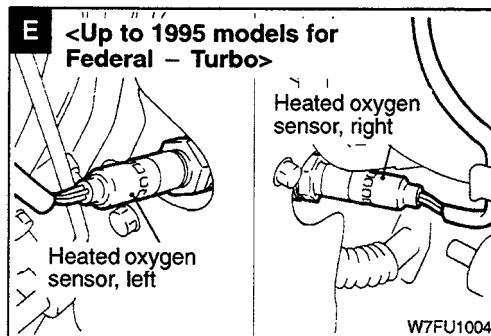
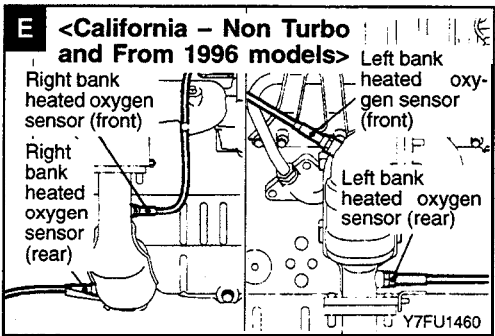
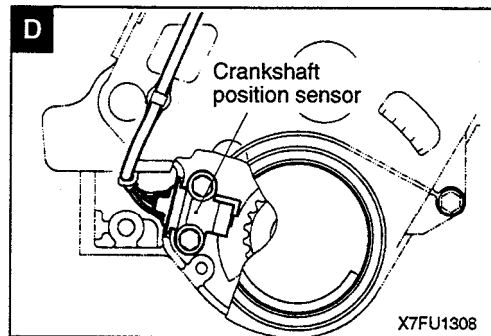
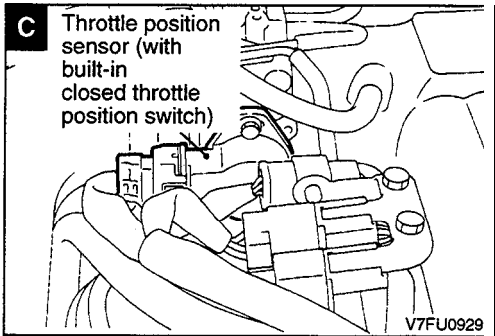
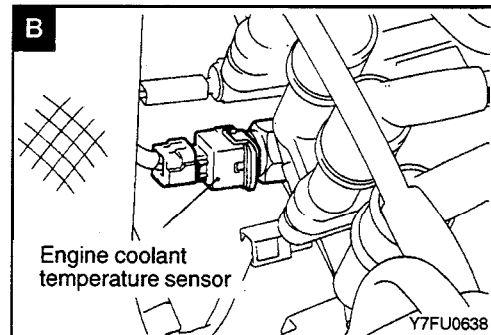
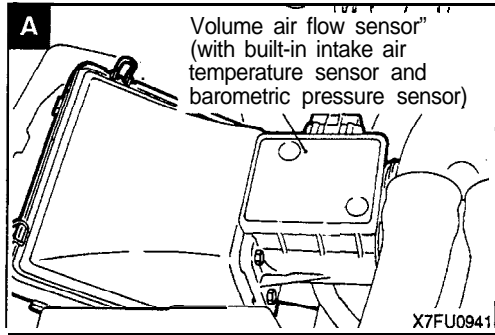

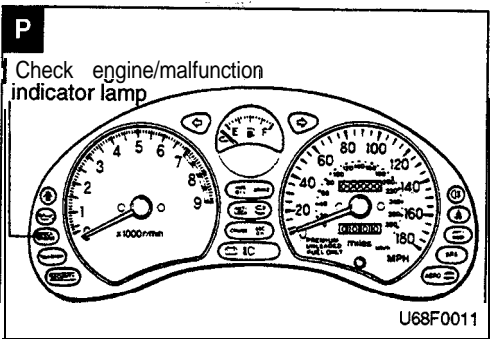
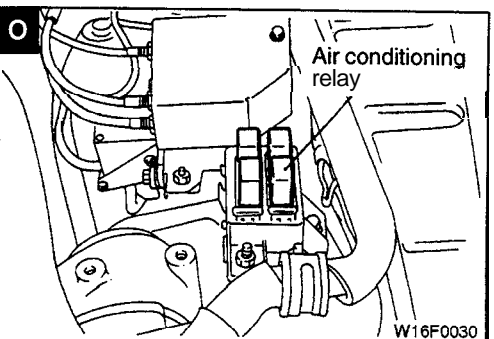
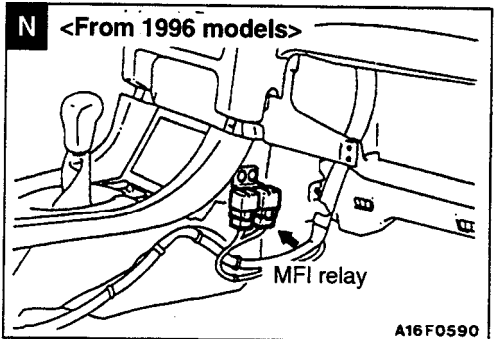
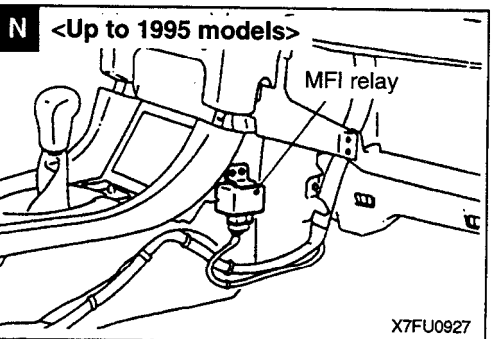
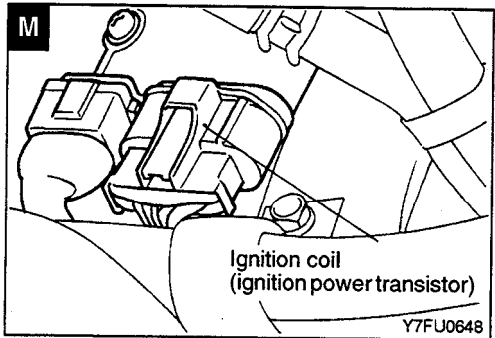
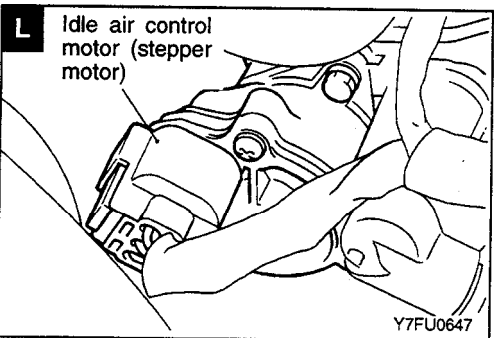
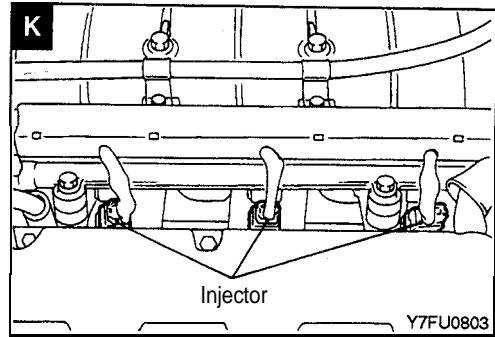
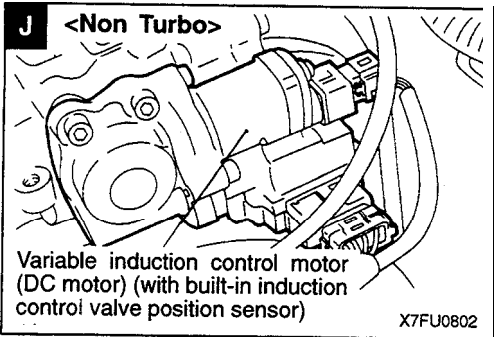
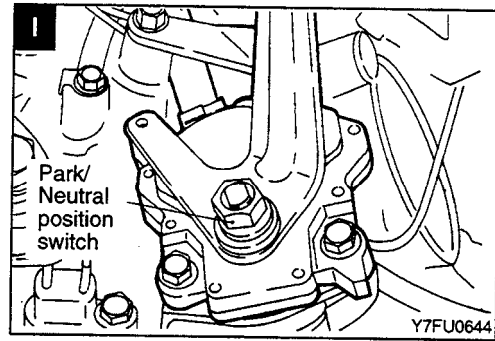
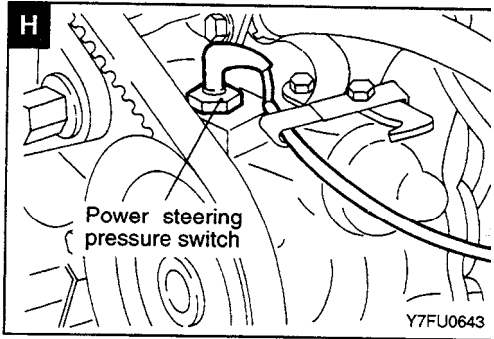

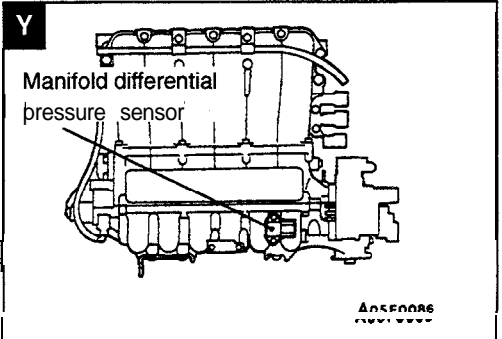
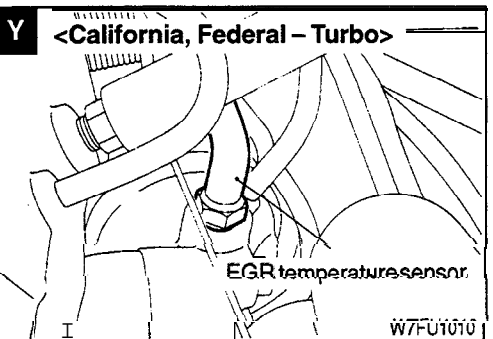
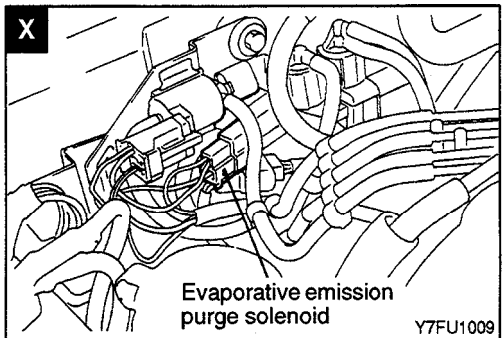
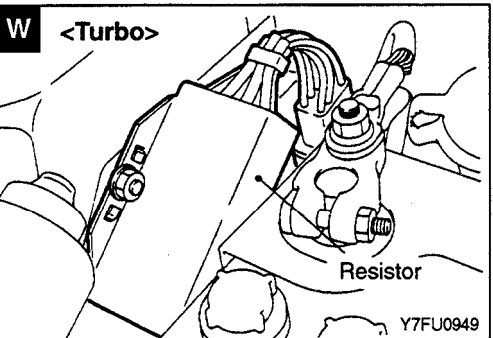
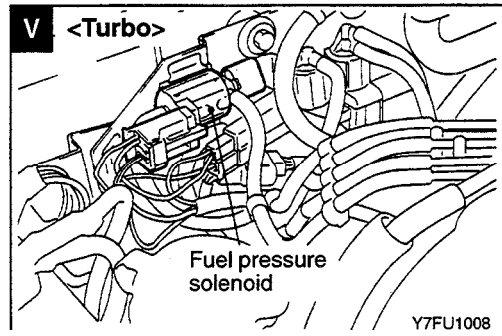
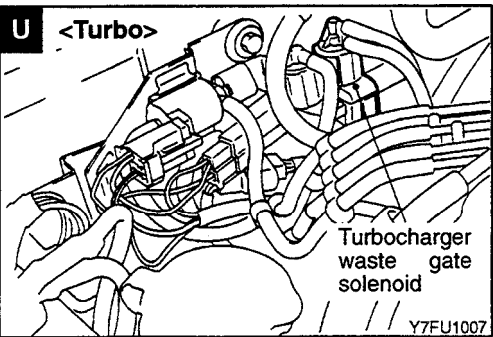
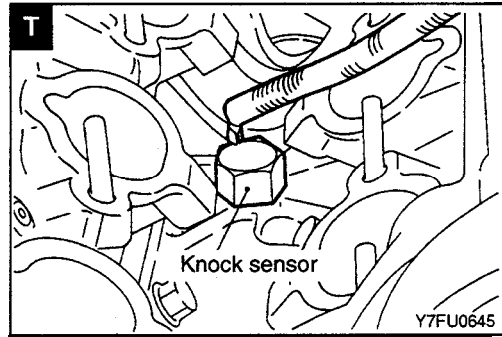
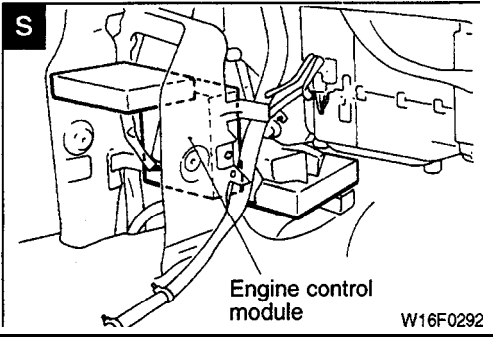
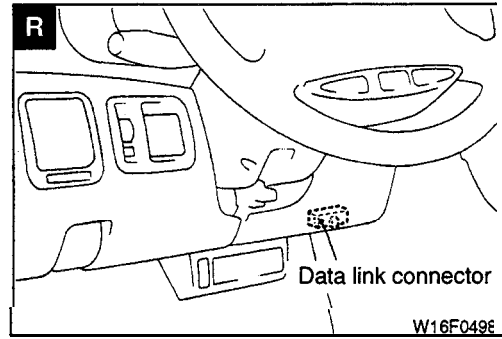
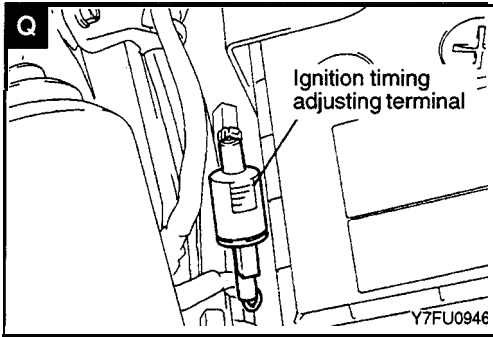

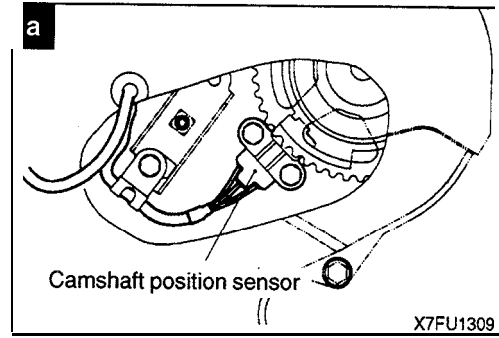
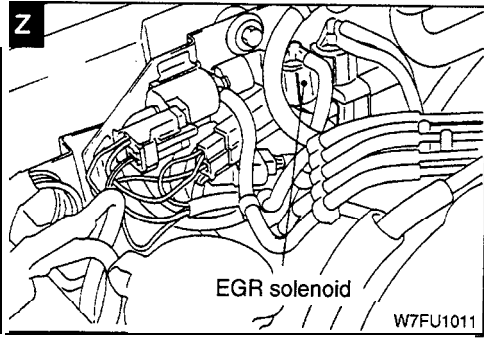



**COOLING**

**COMPONENT LOCATION**

Name	Symbol	Name	Symbol
Air conditioning compressor lock controller	E	Radiator fan motor control relay (up to 1993 models)	B
Air conditioning control unit	D	Radiator fan motor relay (HI)	A
Condenser fan motor relay (Hi)	B	Radiator fan motor relay (LO)	A
Condenser fan motor relay (LO)	B	Thermo sensor	C

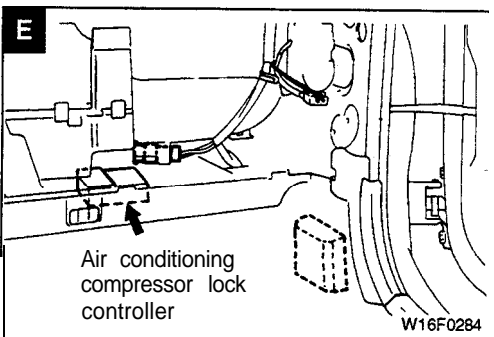
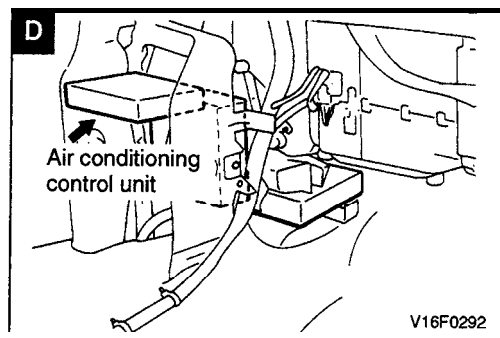
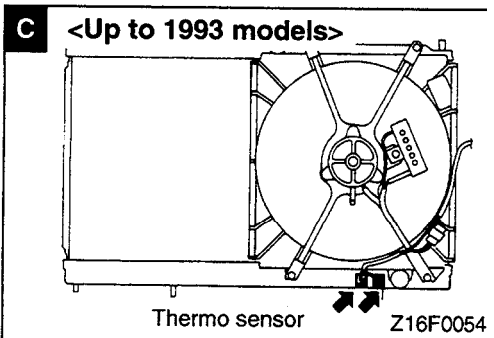
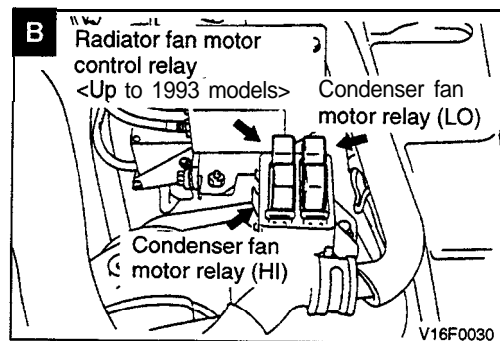
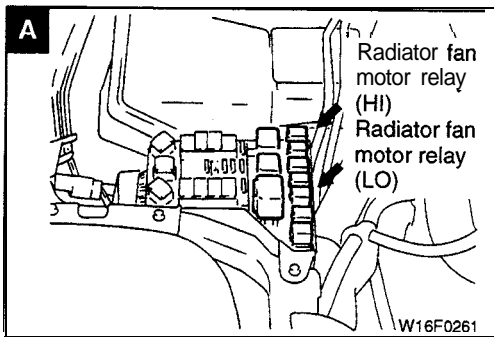
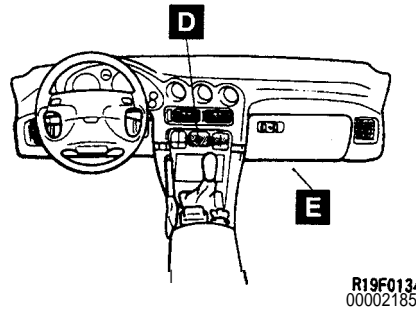
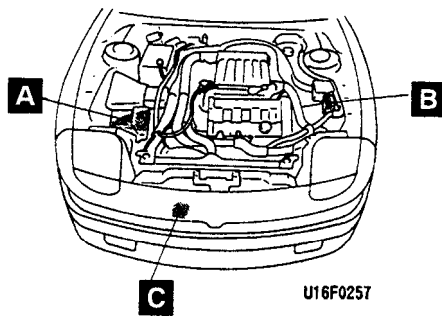

COOLING CIRCUIT (UP TO 1993 MODELS)

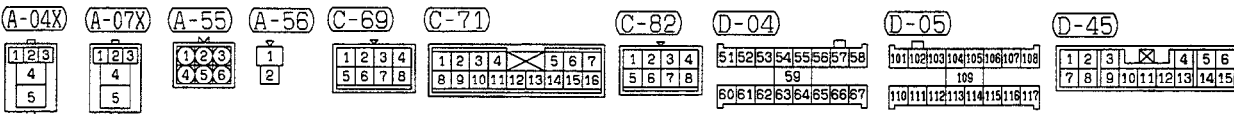
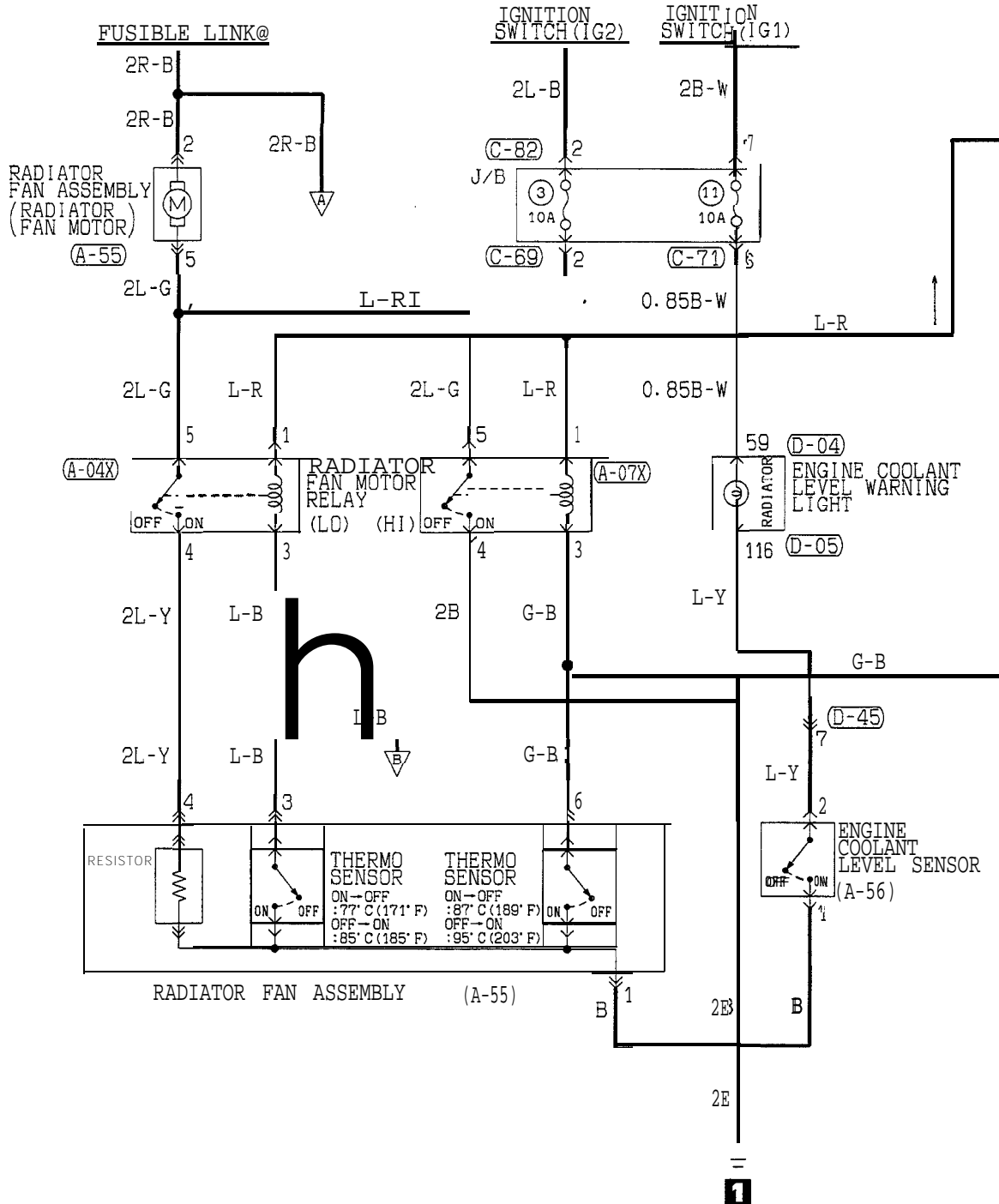

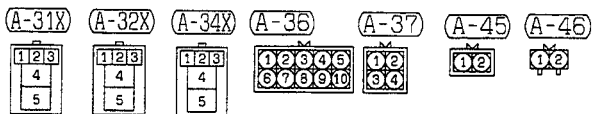
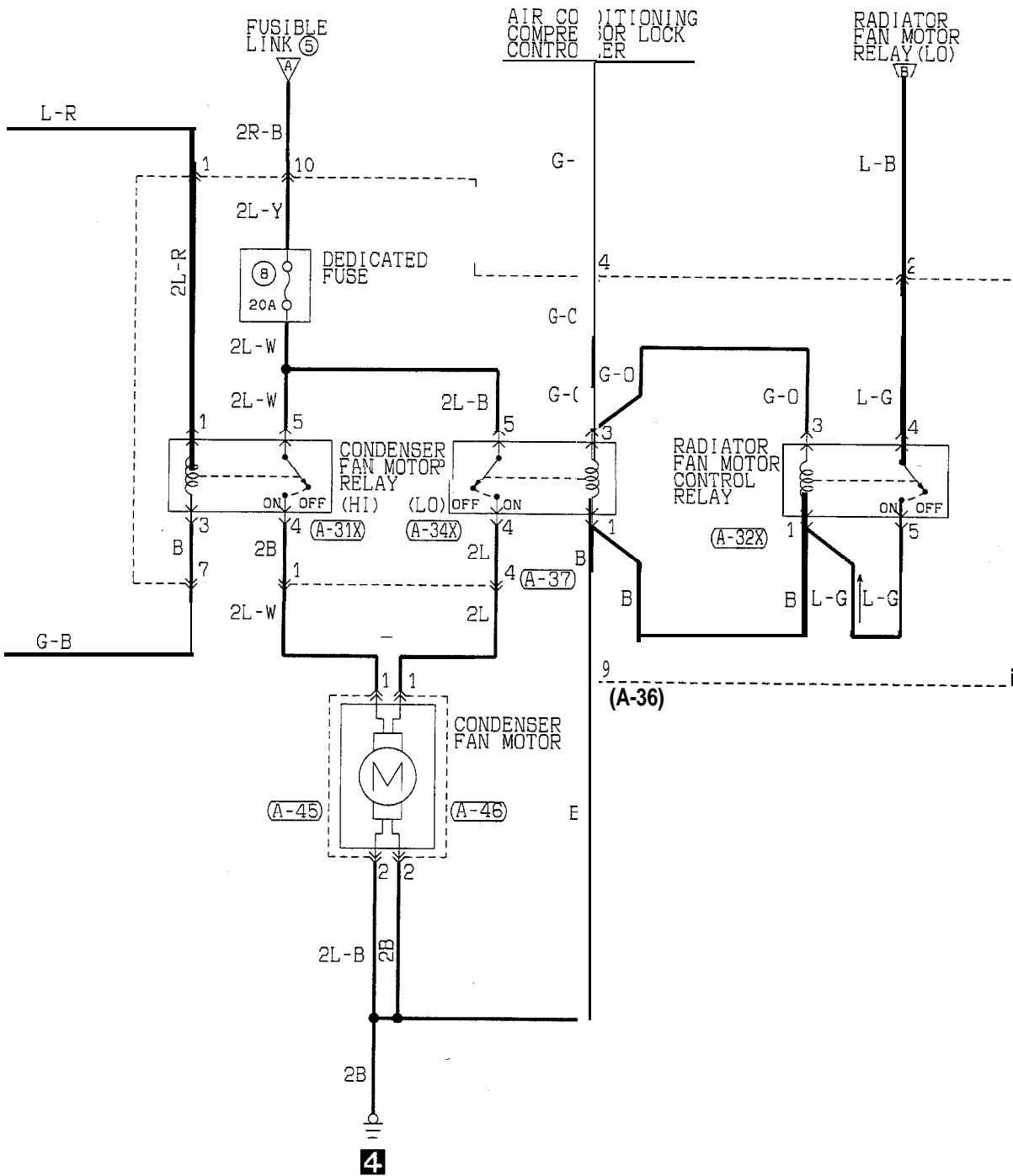

TSB Revision



# COOLING CIRCUIT (1994, 1995 MODELS)

<NON TURBO> (FEDERAL)

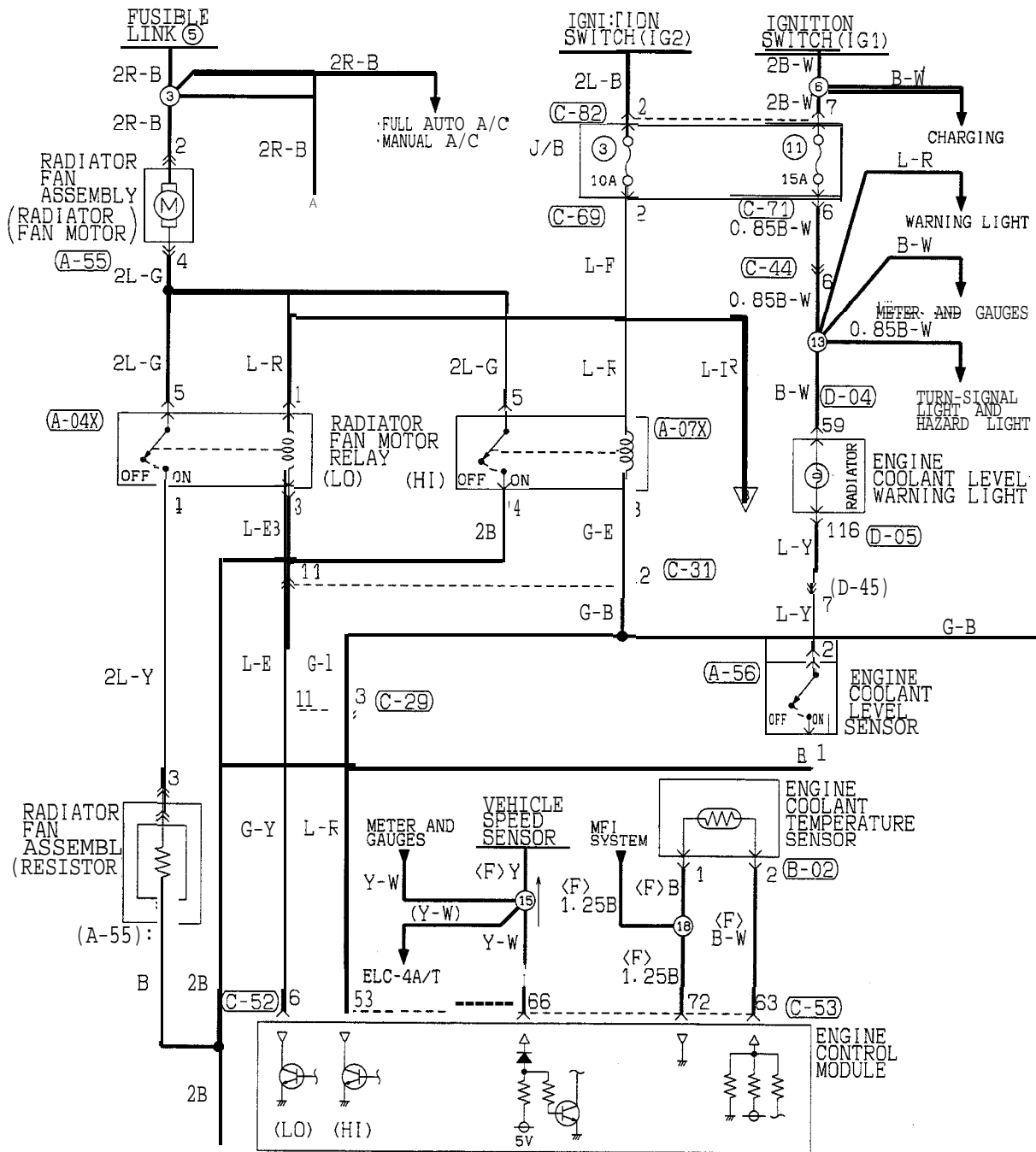

1

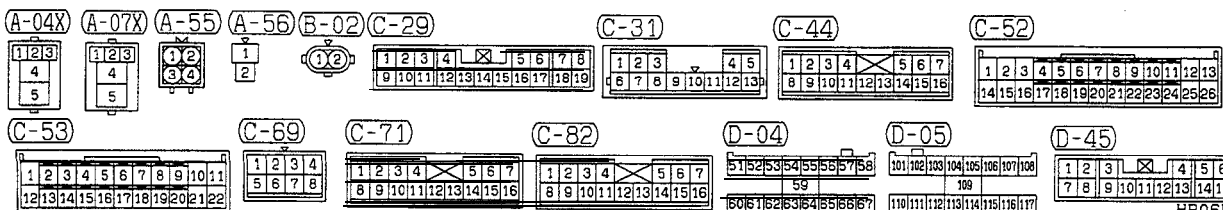

HR06M01AA

TSB Revision

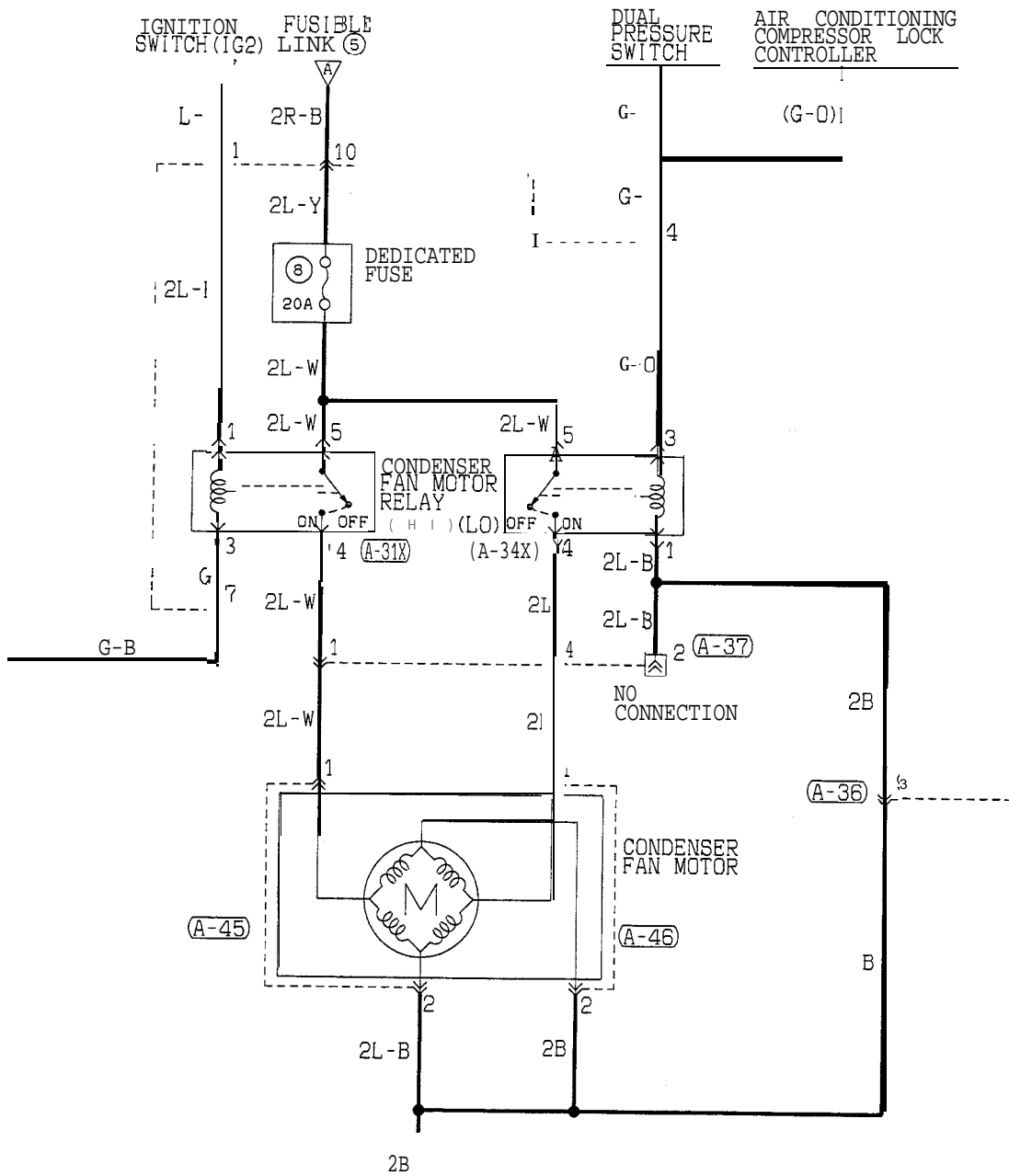

a  
4

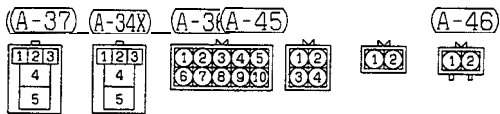

TSB Revision

COOLING CIRCUIT (1994, 1995 MODELS)

<TURBO, NON TURBO (CALIFORNIA)>

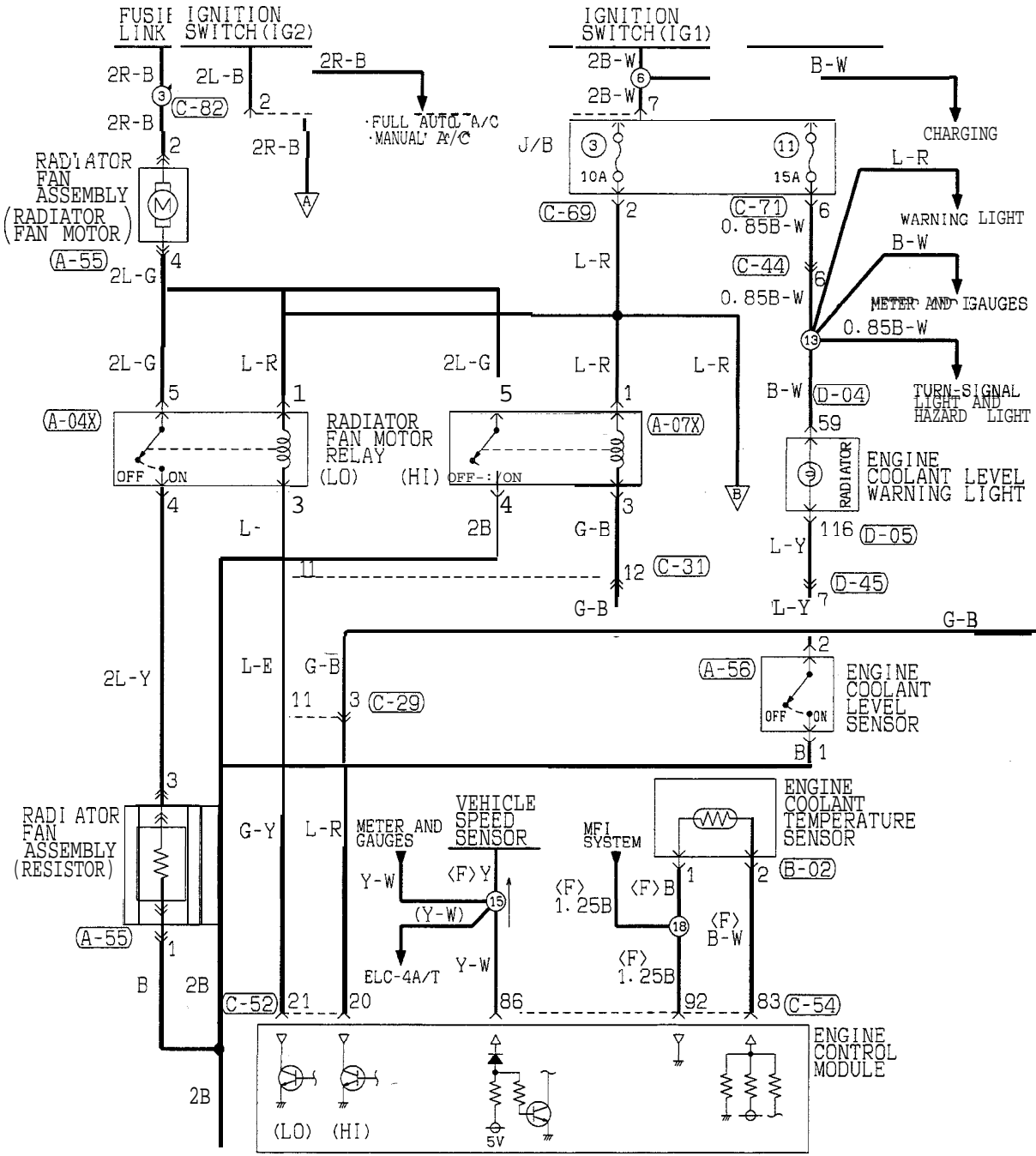

1

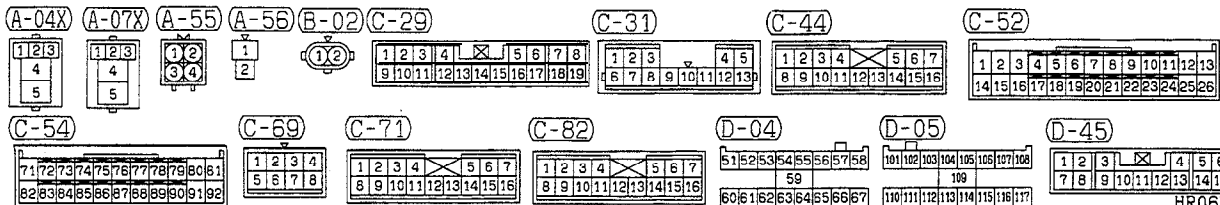

HR06M02AA

TSB Revision

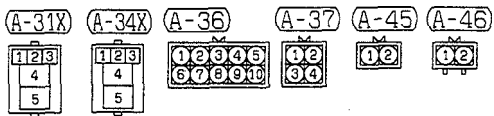
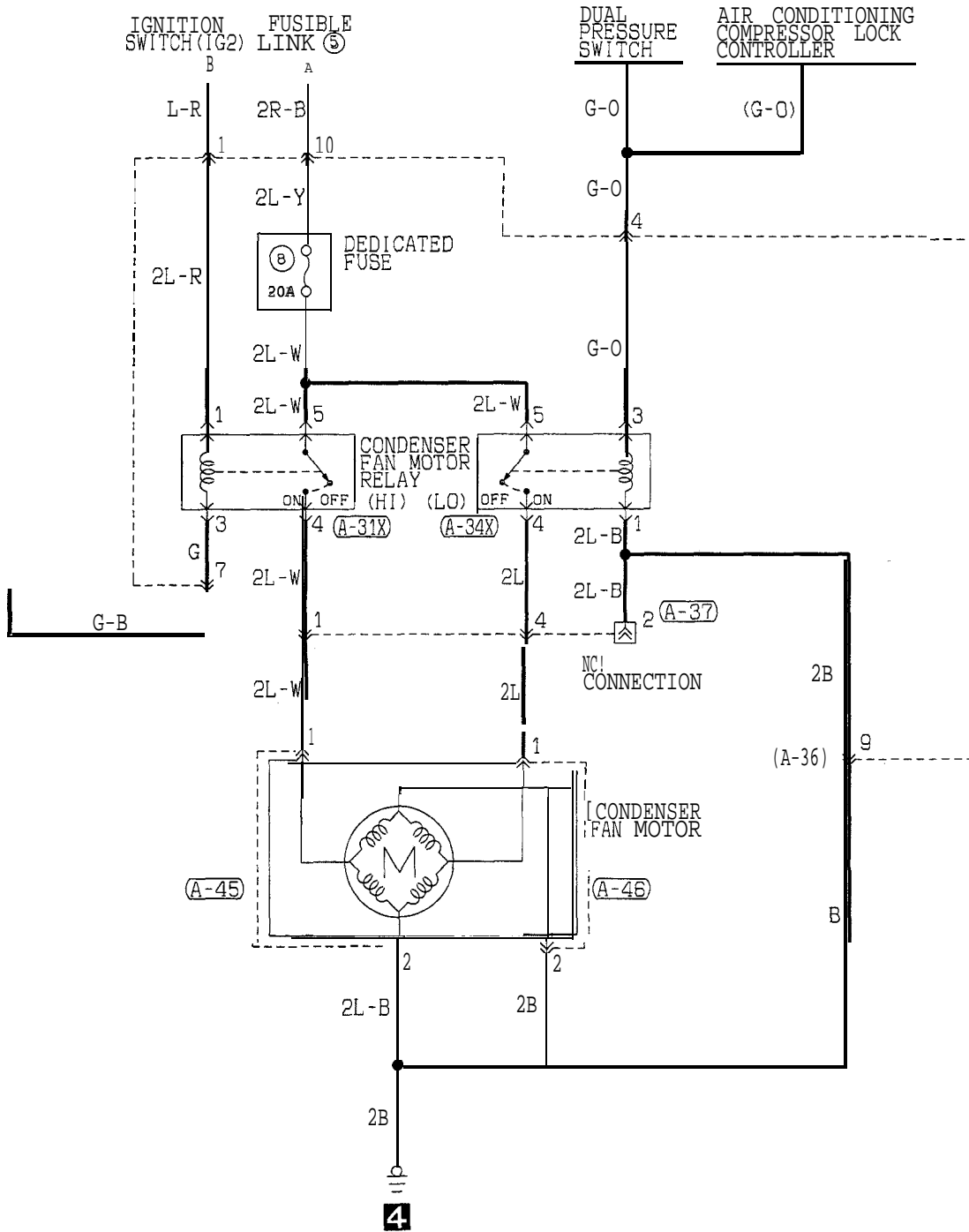

COOLING CIRCUIT (FROM 1996 MODELS)

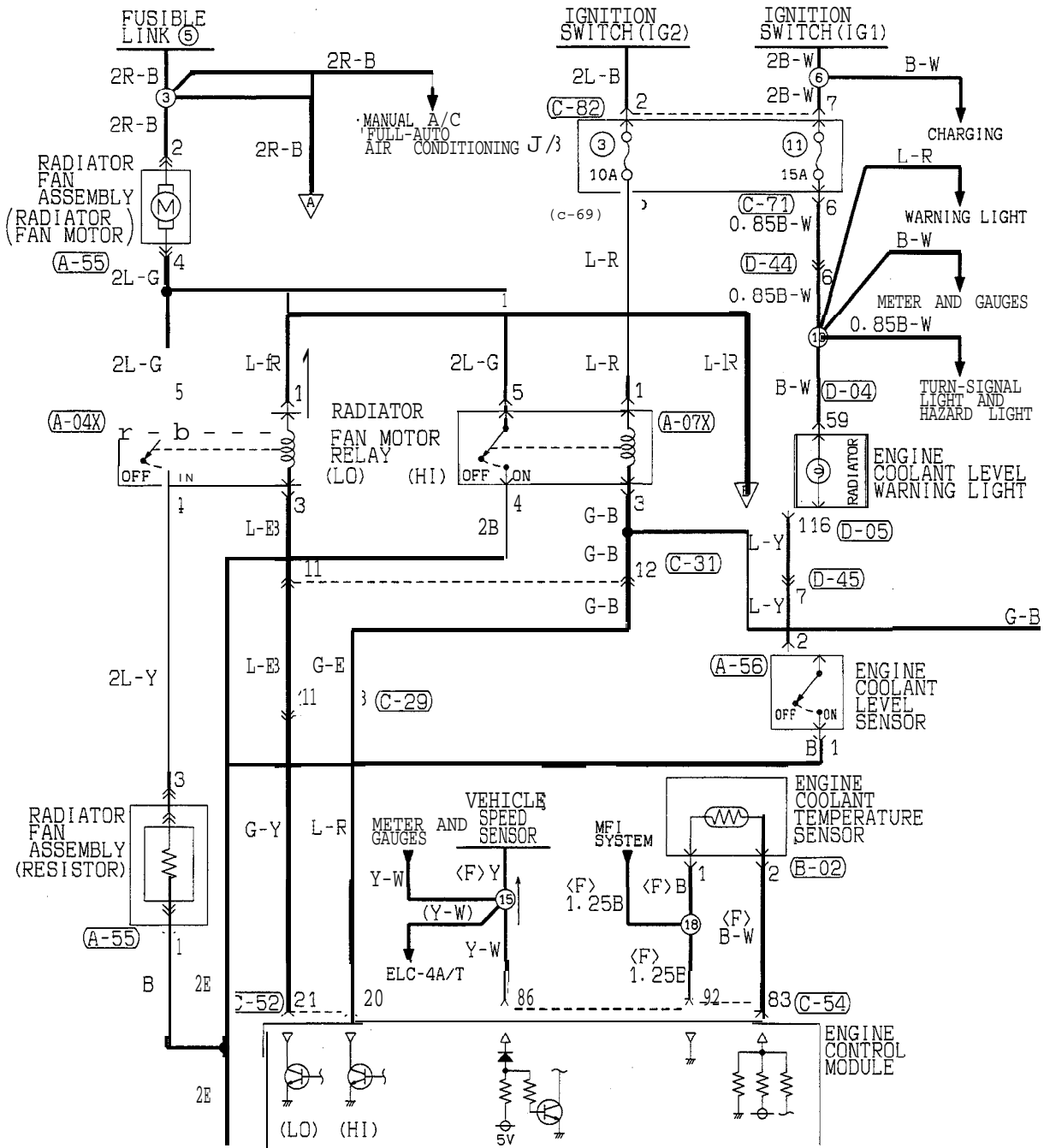

1

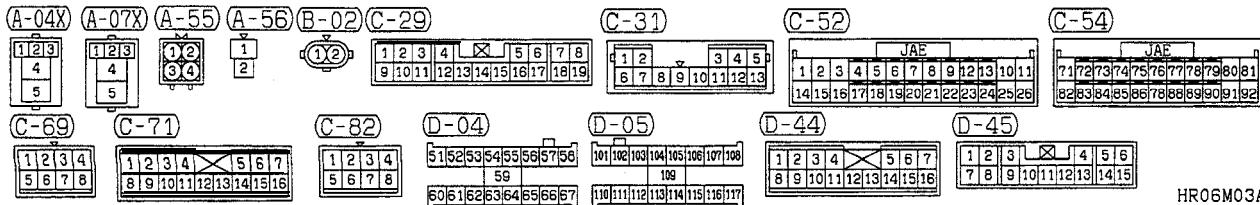

HR06M03AA

TSB Revision

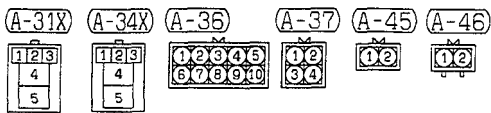
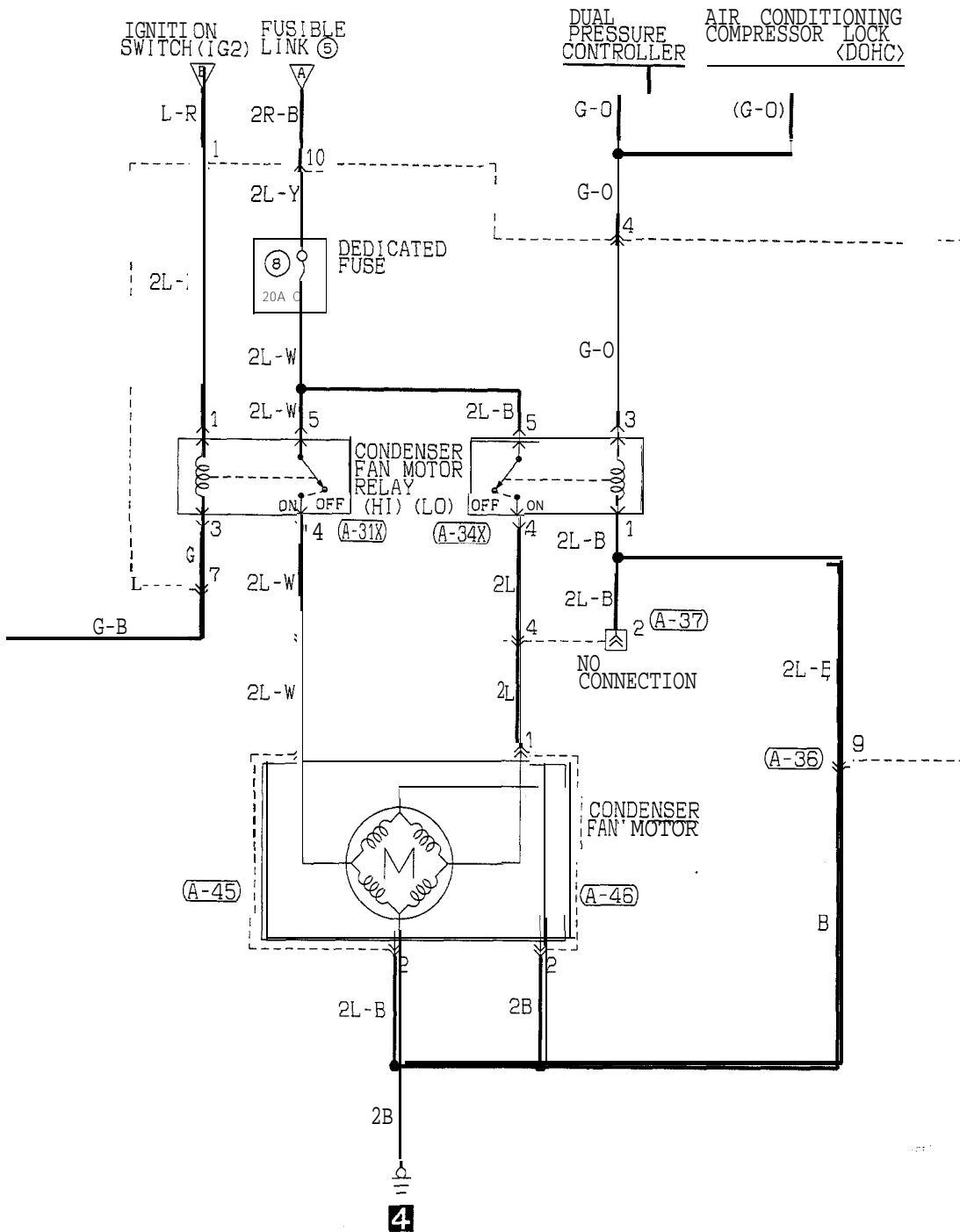

TSB Revision

<Up to 1993 models>  
TROUBLESHOOTING HINTS

1. Neither the radiator fan nor condenser fan rotate at all.

- Check fusible link No. 5

2. Only the condenser fan does not operate.

- Check dedicated fuse No. 8.

3. The radiator fan and condenser fan do not operate in the low speed mode, but operate otherwise.

(1) The A/C compressor magnet clutch does not enter the "ON" state.

- Check whether the output of the auto compressor control unit is available.

NOTE

For troubleshooting of the air conditioning control unit, refer to GROUP 55.

(2) The A/C compressor magnet clutch enters the "ON" state.

- Check the resistor.

- Check the radiator fan motor relay (LO) and condenser fan motor relay (LO).
- Check the thermo sensor (for radiator fan).

(3) The radiator fan does not rotate when the air conditioning switch is turned ON.

- Check the radiator fan motor control relay.

4. The radiator fan and condenser fan do not operate in the high speed mode, but operate otherwise.

- Check the thermo sensor (for condenser fan).
- Check the radiator fan motor relay (HI) and condenser fan motor relay (HI).

Fan Operating Mode

Air conditioning switch	Thermo sensor for radiator fan ON at 85 ± 4°C (185 ± 7°F) or more OFF at 77°C (171°F) or less	Thermo sensor for condenser fan ON at 95 ± 4°C (203 ± 7°F) or more OFF at 87°C (189°F) or less	A/C engine coolant temperature switch (for air conditioning cut-off) OFF at 115 ± 3°C (239 ± 5°F) or over, ON at 108°C (226°F) or less	Radiator fan motor	Condenser fan motor Condenser fan motor operates in HIGH only when it receives input from condenser fan motor relay (HI) and (LO).
OFF	OFF	OFF	-	OFF	OFF
	ON	OFF		LOW	OFF
		ON		HIGH	LOW
ON	OFF	OFF	ON	LOW	LOW
	ON	OFF		LOW	LOW
		ON		ON	HIGH
			OFF	HIGH	LOW

**<From 1994 models>  
OPERATION**

The engine control module controls the power transistors (high speed and low speed) in the module to provide radiator fan motor and condenser fan motor rotation controls in accordance with the engine coolant temperature and vehicle speed.

**1. Radiator Fan (Low Speed Rotation)**

- When the engine control module turns on the power transistor (low speed) in the module, the current flows from the ignition switch to the engine control module through the radiator fan motor relay (LO) coil. If the current flows to the fan motor relay coil, the switch of the relay turns on to supply the motor driving power (for low speed rotation). This will cause the current to flow from the battery to the ground through the radiator fan motor, relay switch and resistor, rotating the radiator fan at low speeds.

**2. Condenser Fan (Low Speed Rotation)**

- The power from the A/C compressor lock controller turns on the condenser fan motor relay (LO) to rotate the condenser fan at low speeds.

**3. Radiator Fan, Condenser Fan (High Speed Rotation)**

- When the engine control module turns on the power transistor (high speed) in the module, the radiator fan motor relay (HI) and condenser fan motor relay (HI) will operate and the motor driving power (for high speed rotation) is sent to the radiator fan motor and condenser fan motor to rotate the radiator fan and condenser fan at high speeds.

**NOTE**

In the event of faulty water temperature sensor, the engine control module commands the fan motors (for both radiator and condenser) to rotate at high speeds.

**TROUBLESHOOTING HINTS**

**1. Neither the radiator fan nor condenser fan rotate at all.**

- Check fusible link No. 5.

**2. Only the condenser fan does not operate.**

- Check dedicated fuse No. 8.

**3. The condenser fan do not operate in the low speed mode, but operate otherwise.**

- The A/C compressor magnet clutch does not enter the "ON" state.
  - Check whether the output of the air conditioning compressor lock controller unit is available.
- The A/C compressor magnet clutch enters the "ON" state.
  - Check the condenser fan motor relay (LO).

**4. The radiator fan and condenser fan do not operate in the high speed mode, but operate otherwise.**

- Check the engine control unit.

**Fan Operating Mode**

A/C compressor lock controller output	Vehicle speed km/h [mph]	Engine coolant temperature °C [°F]	Transistor in engine control unit Low speed	Transistor in engine control unit High speed	Radiator fan	Condenser fan
LO (0V)	80 or less [50 or less]	Approx. 95 [203] or less	OFF	OFF	OFF	OFF
		Approx. 95 [203] or more	ON	OFF	Low speed	OFF
		Approx. 105 [221] or more	ON	ON	High speed	High speed
	80 or more [50 or more]	Approx. 105 [221] or less	OFF	OFF	OFF	OFF
		Approx. 105 [221] or more	ON	ON	High speed	High speed
HI (12V)	-	Approx. 105 [221] or less	ON	OFF	Low speed	Low speed
		Approx. 105 [221] or more	ON	ON	High speed	High speed



ELC-4 A/T CIRCUIT (1992 MODEL)

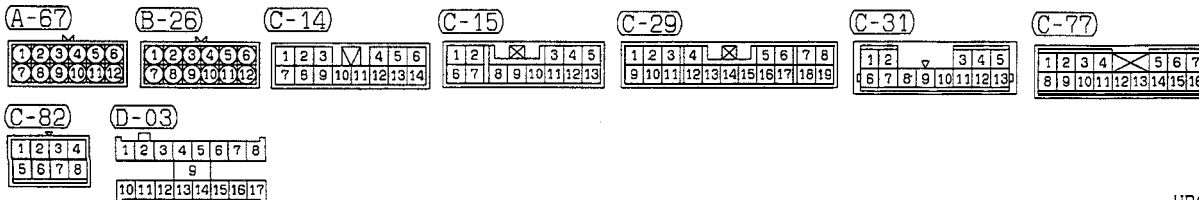
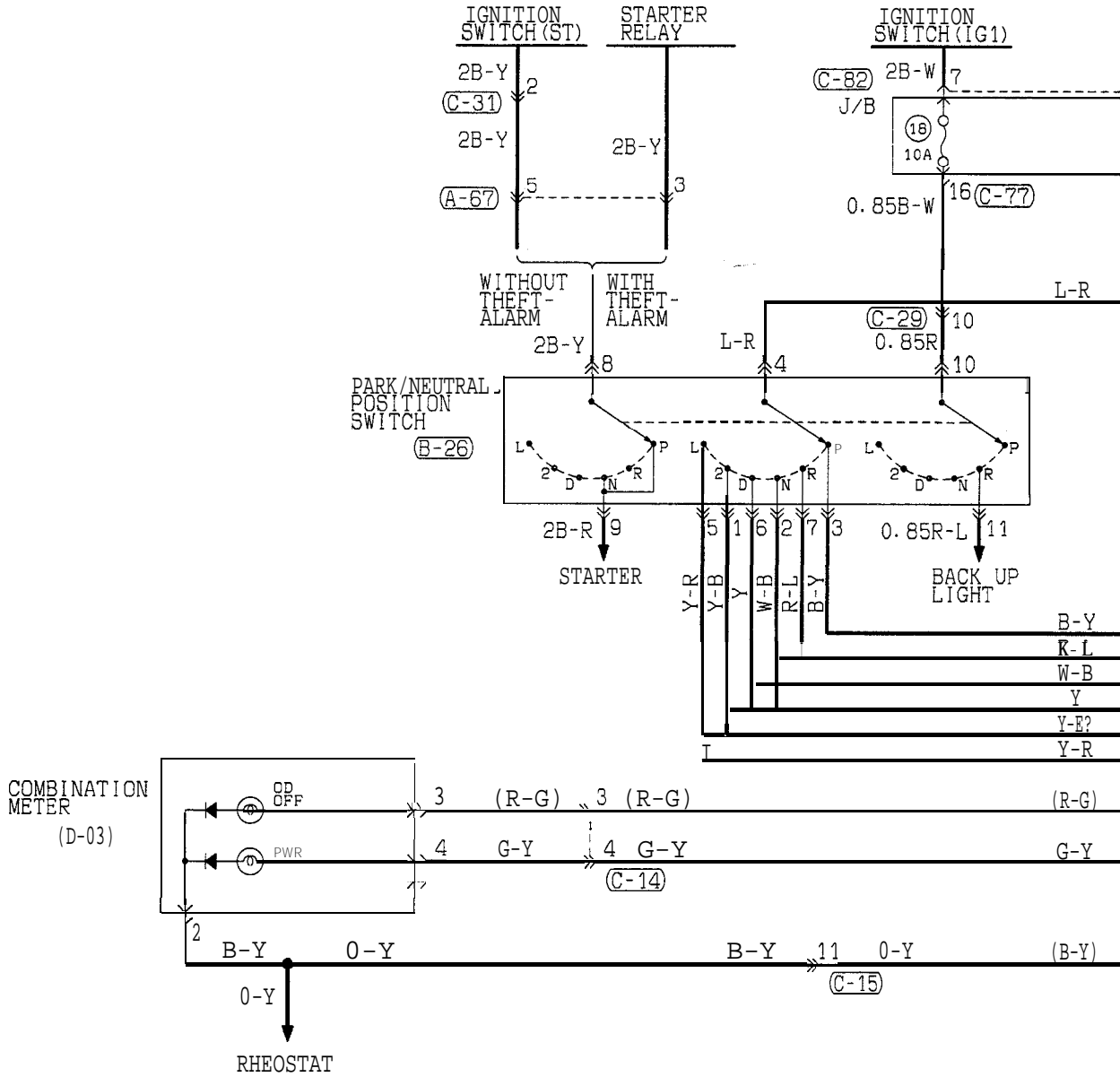

HR07M00AA

TSB Revision

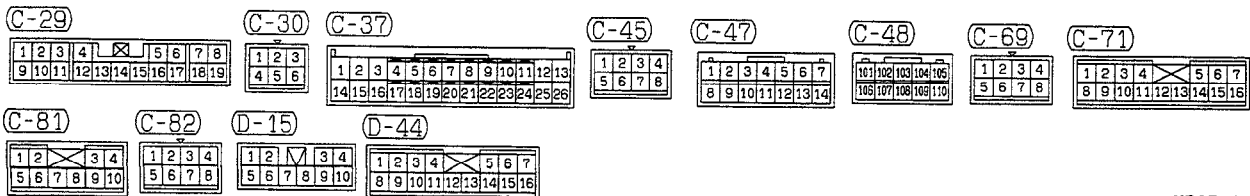
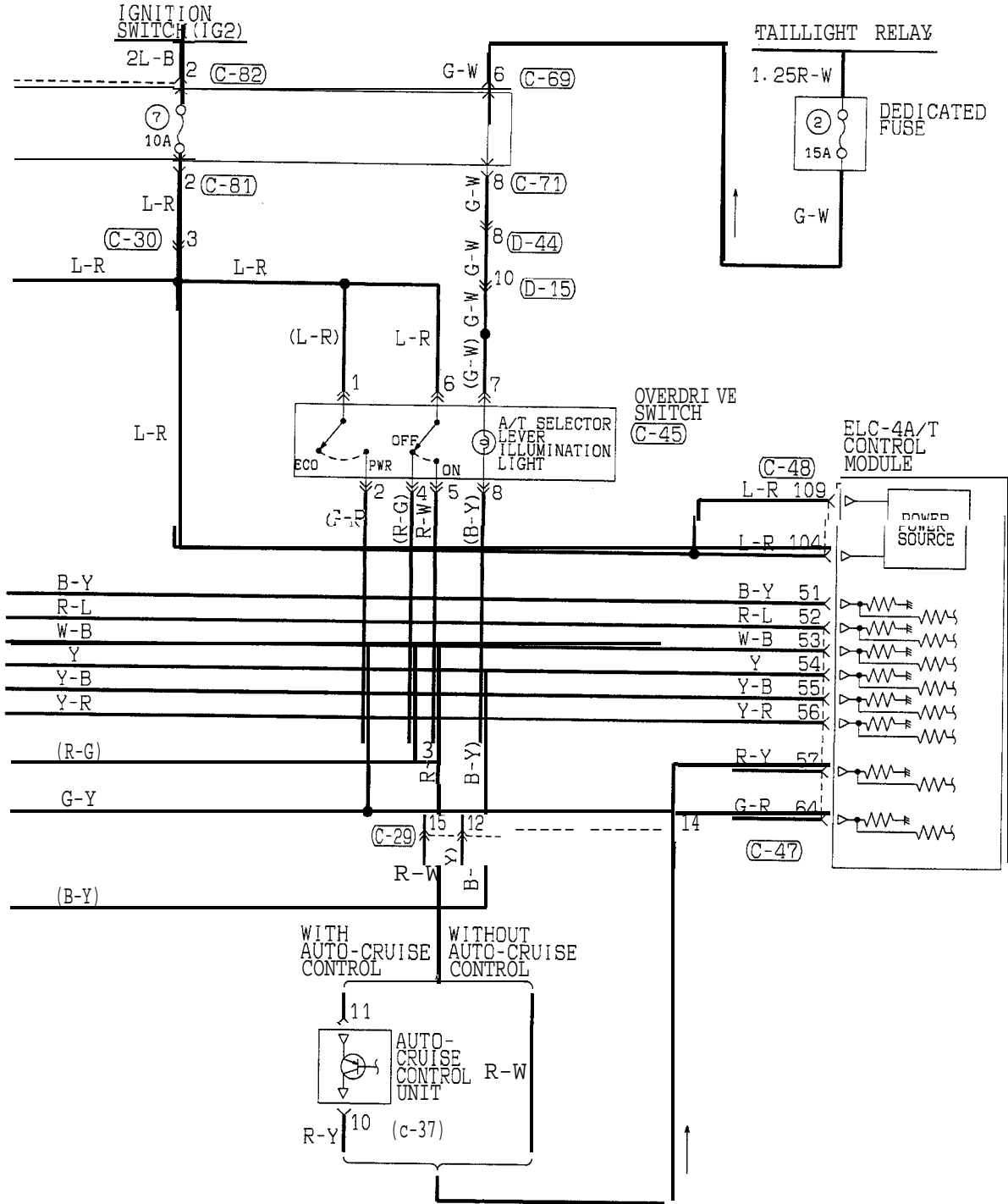

HR07M00AB

TSB Revision

ELC-4 A/T CIRCUIT (1992 MODEL) (CONTINUED)

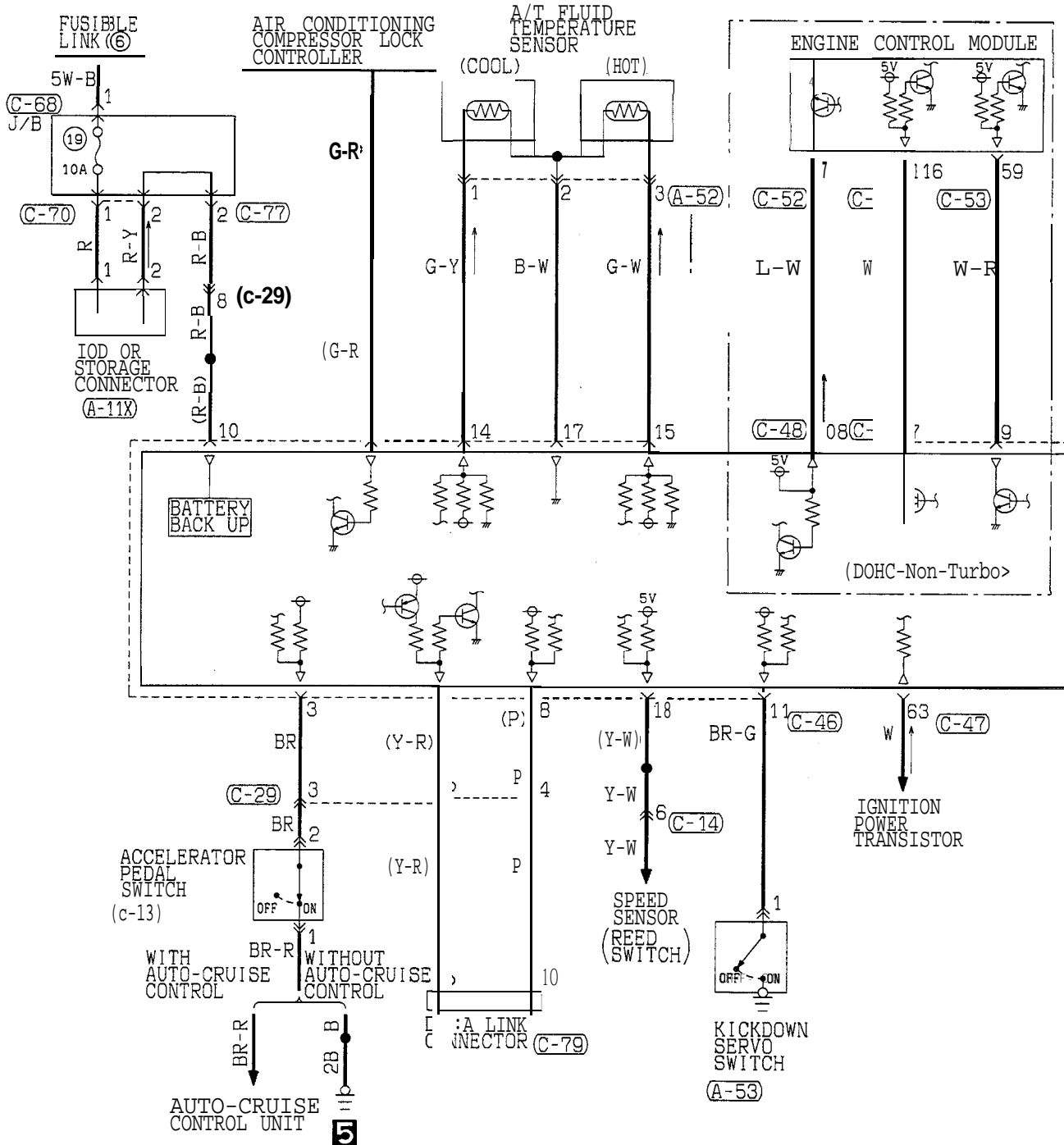

<b>A-11X</b> 1 2 3 4	<b>A-52</b> 1 2 3 4	<b>A-53</b> 1	<b>C-13</b> 1 2	<b>C-14</b> 1 2 3 4 5 6 7 8 9 10 11 12 13 14	<b>C-29</b> 1 2 3 4 5 6 7 8 9 10 11 12 13 14 15 16 17 18 19	<b>C-46</b> 1 2 3 4 5 6 7 8 9 10 11 12 13 14 15 16 17 18	<b>C-47</b> 5 1 52 53 54 55 56 57 58 59 60 61 62 63 64	<b>C-48</b> 101 102 103 104 105 106 107 108 109 110
<b>C-52</b> 1 2 3 4 5 6 7 8 9 10 11 12 13 14 15 16 17 18 19 20 21 22 23 24 25 26	<b>C-53</b> 1 2 3 4 5 6 7 8 9 10 11 12 13 14 15 16 17 18 19 20 21 22	<b>C-54</b> 1 2 3 4 5 6 7 8 9 10 11 12 13 14 15 16	<b>C-68</b> 1	<b>C-70</b> 1 2 3 4	<b>C-77</b> 1 2 3 4 5 6 7 8 9 10 11 12 13 14 15 16	<b>C-79</b> 5 4 3 2 1 12 11 10 9 8 7 6	<b>FRONT SIDE</b> 1 2 3 4 5	<b>REAR SIDE</b> 1 2 3 4 5

HR07M00BA

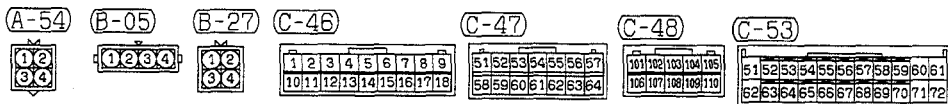
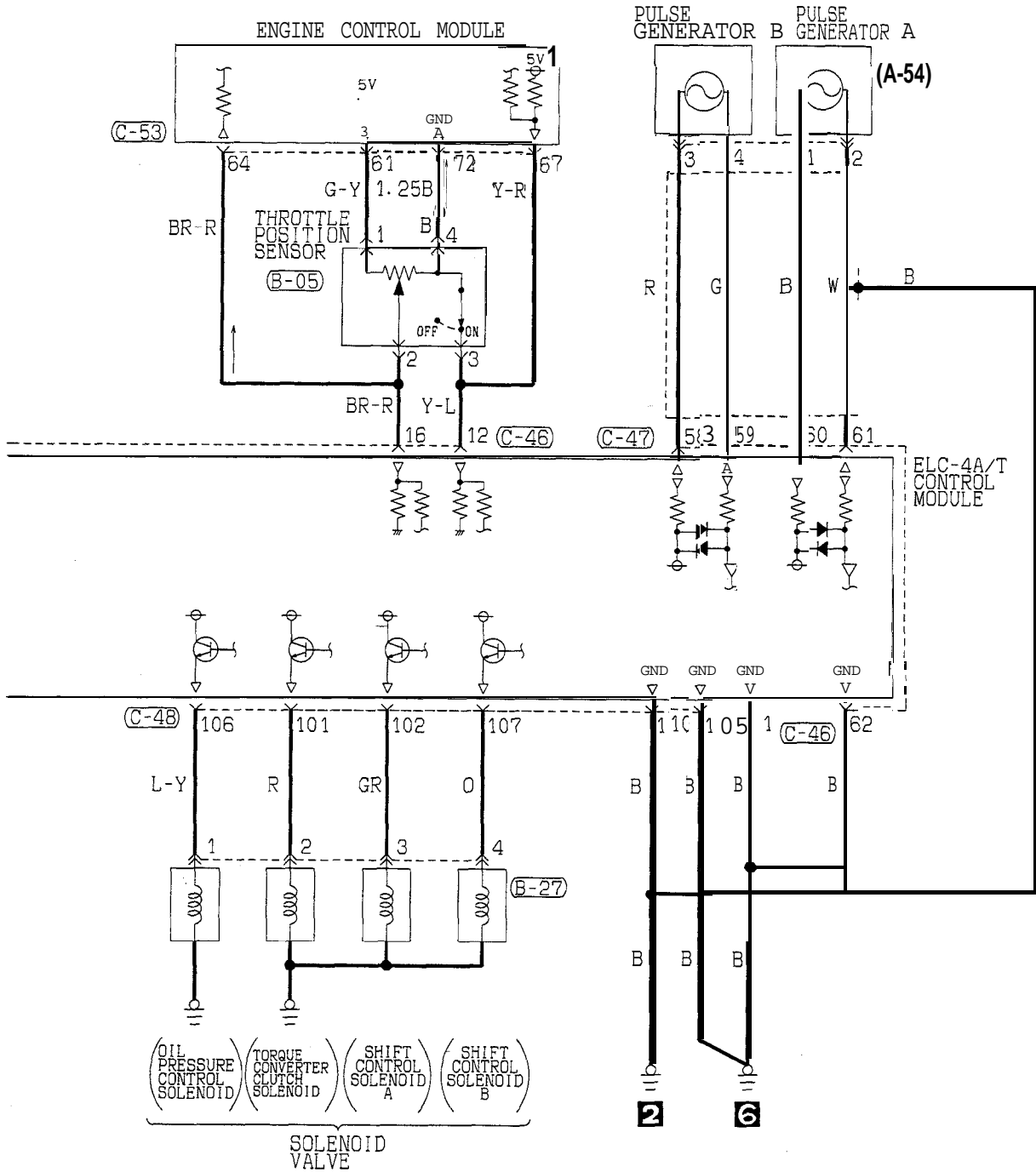

ELC-4 A/T CIRCUIT (1993 MODELS)

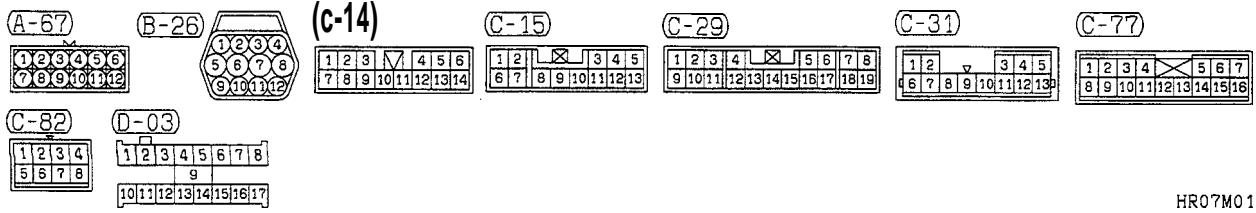
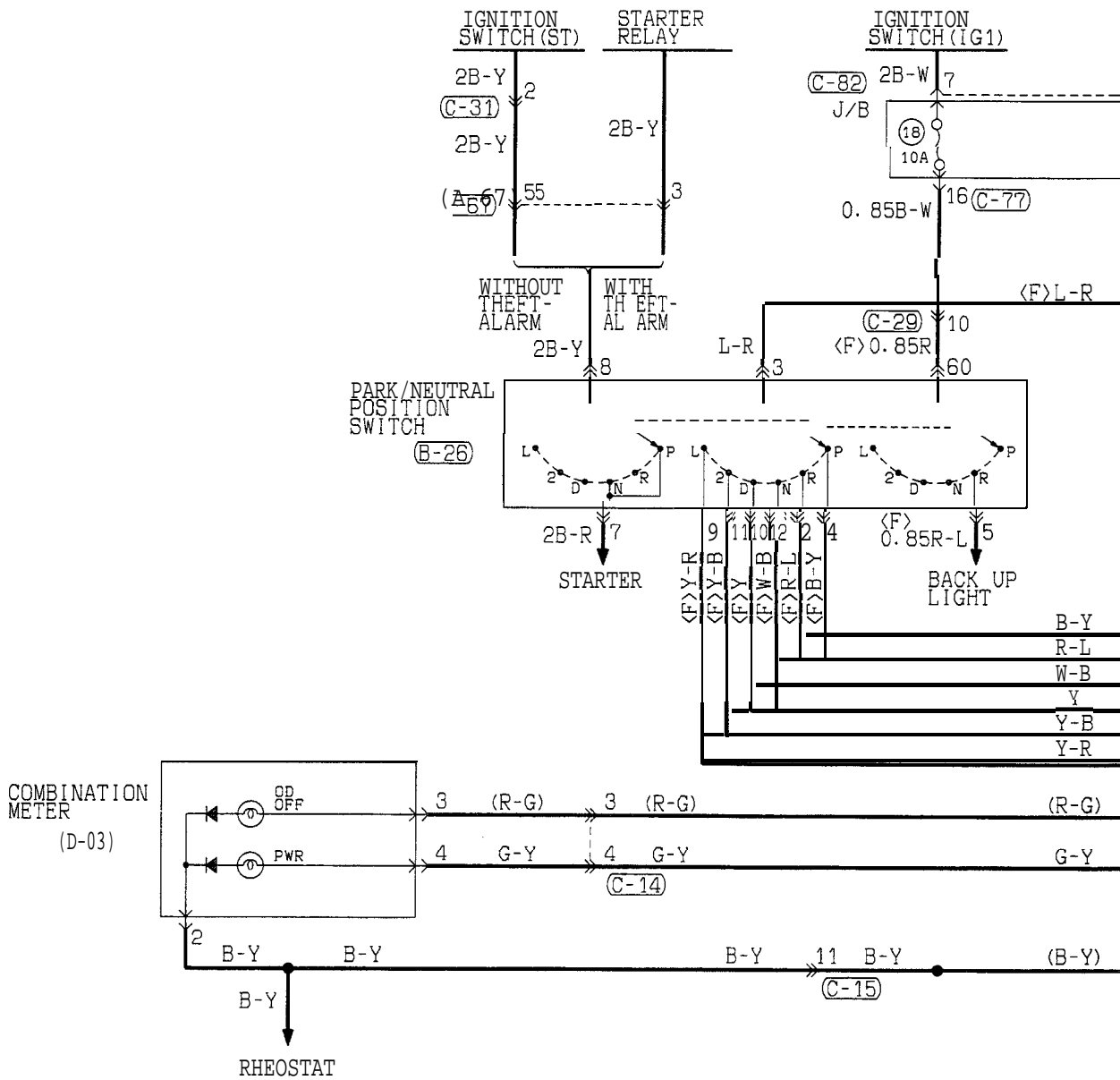

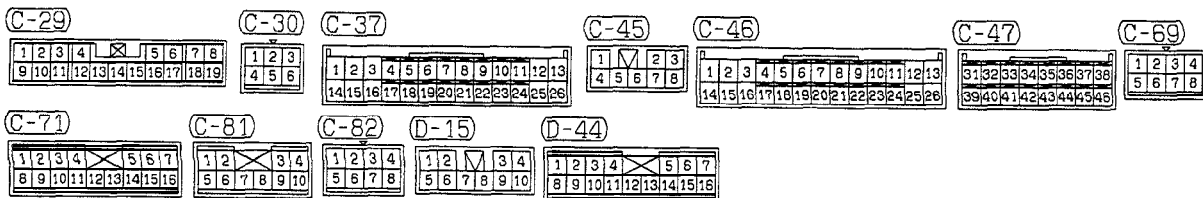
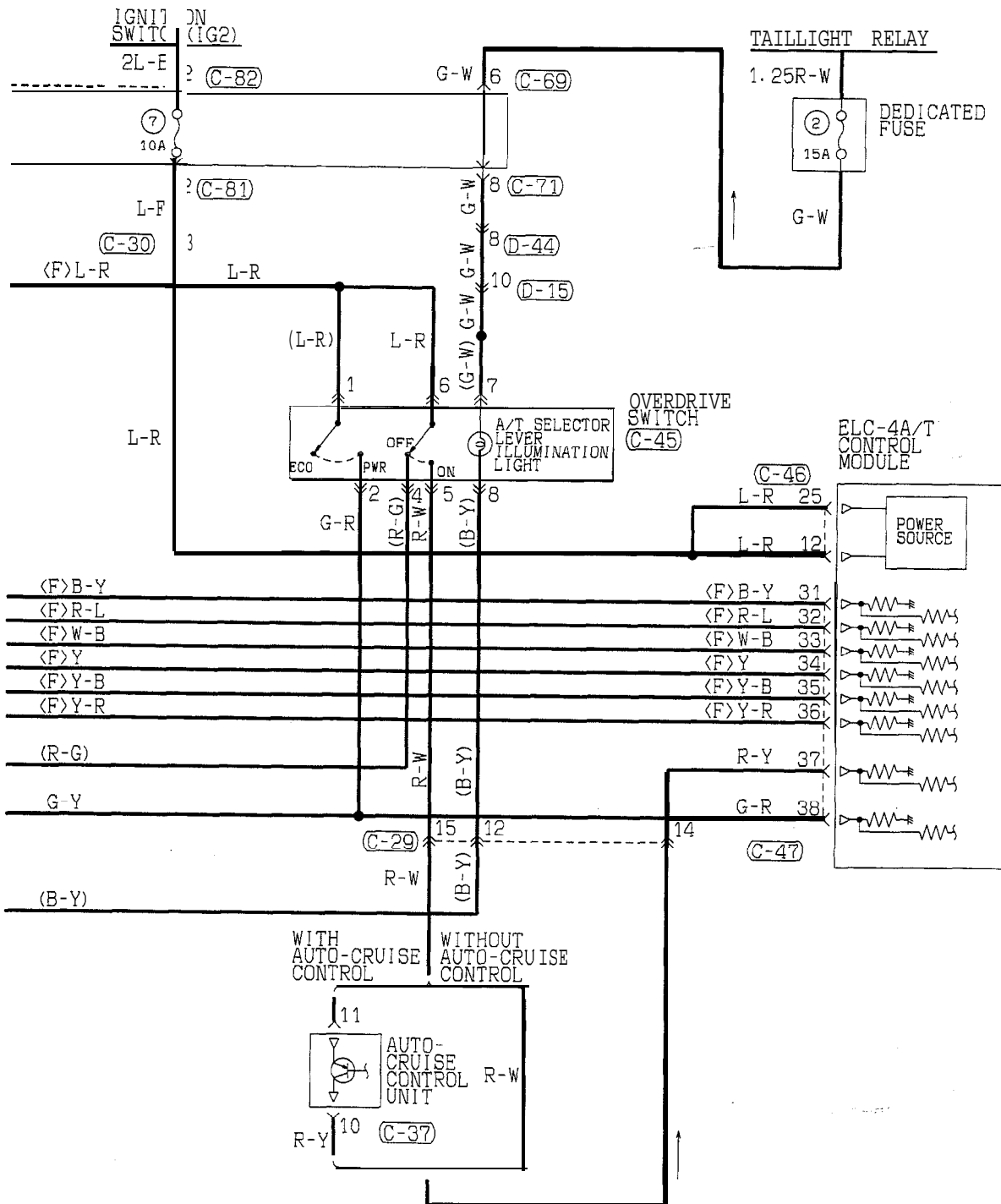

TSB Revision

ELC-4 AT CIRCUIT (1993 MODELS) (CONTINUED)

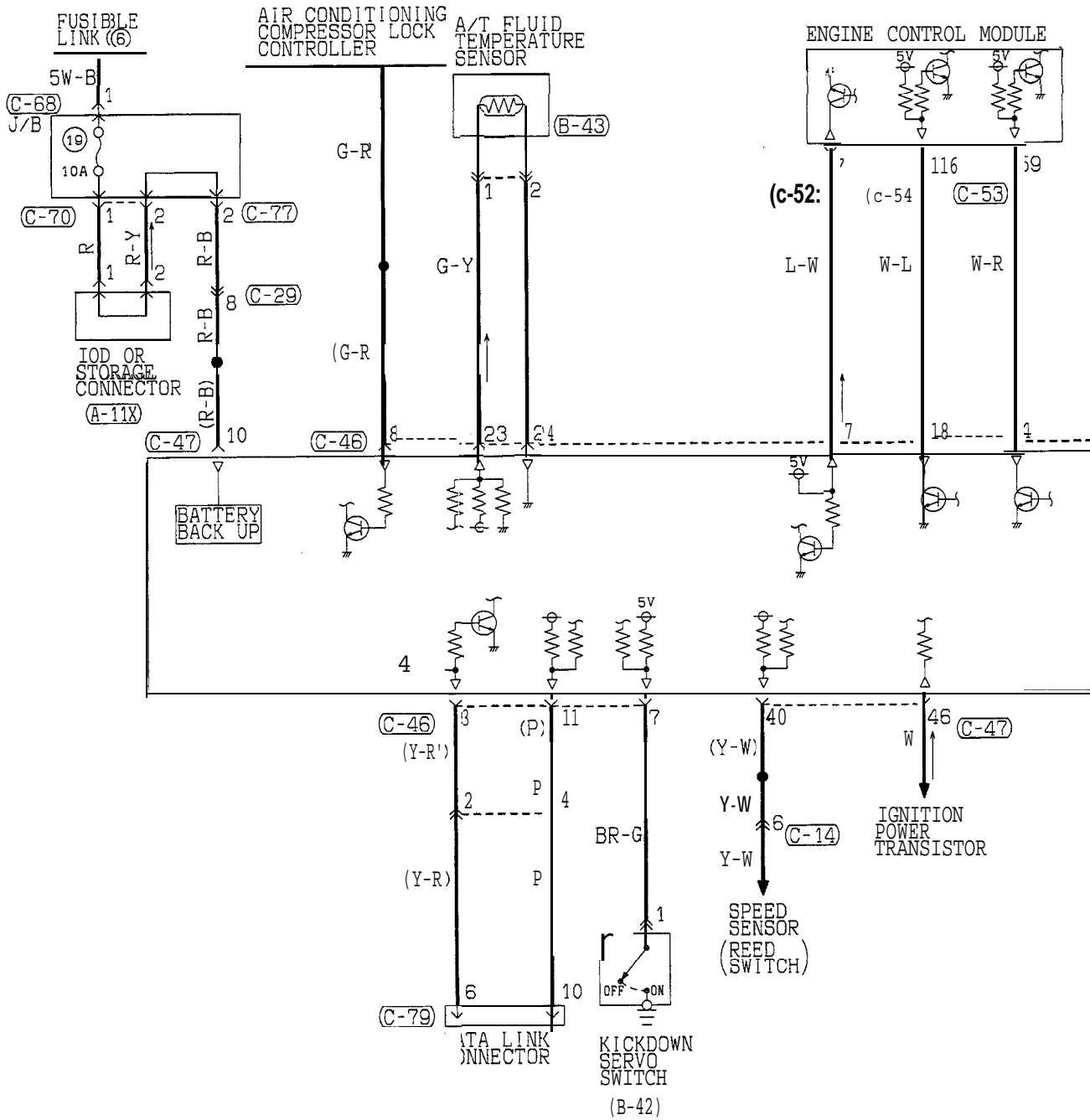

<b>A-11X</b> M 1 2 3 4	<b>B-42</b> 1 2	<b>B-43</b> 1 2	<b>C-14</b> 1 2 3 4 5 6 7 8 9 10 11 12 13 14	<b>C-29</b> 1 2 3 4 5 6 7 8 9 10 11 12 13 14 15 16 17 18 19	<b>C-46</b> 1 2 3 4 5 6 7 8 9 10 11 12 13 14 15 16 17 18 19 20 21 22	<b>C-47</b> 31 32 33 34 35 36 37 38 39 40 41 42 43 44 45 46
<b>C-52</b> 1 2 3 4 5 6 7 8 9 10 11 12 13 14 15 16 17 18 19 20 21 22 23 24 25 26	<b>C-53</b> 1 2 3 4 5 6 7 8 9 10 11 12 13 14 15 16 17 18 19 20 21 22	<b>C-54</b> 1 2 3 4 5 6 7 8 9 10 11 12 13 14 15 16	<b>C-68</b> 1	<b>C-70</b> M 1 2 3 4	<b>C-77</b> 1 2 3 4 5 6 7 8 9 10 11 12 13 14 15 16	<b>C-79</b> FRONT SIDE 5 4 3 2 1 12 11 10 9 8 7 6 REAR SIDE 1 2 3 4 5 6 7 8 9 10 11 12

HR07M01BA

TSB Revision

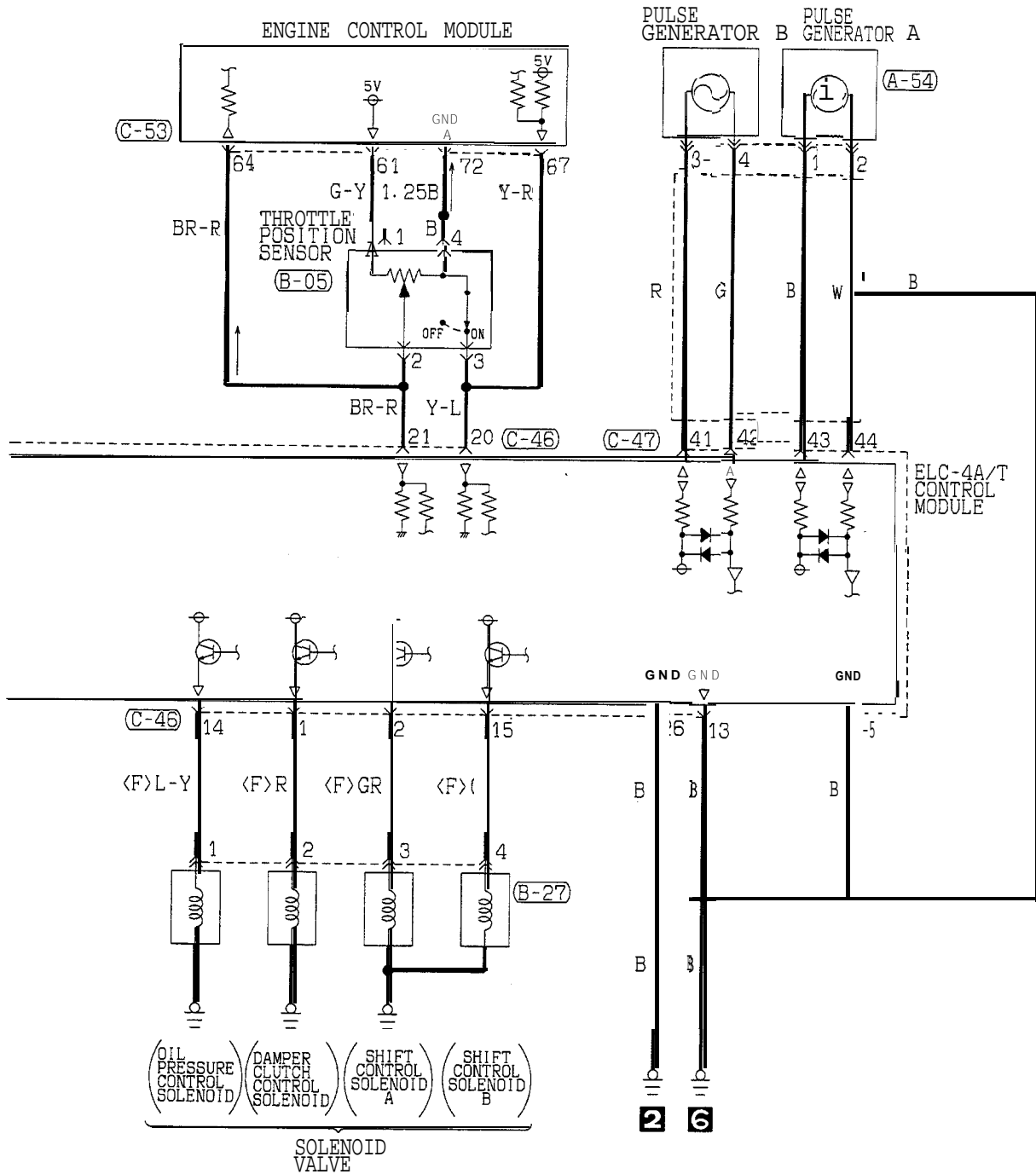

(A-54)	(B-05)	(B-27)	(C-46)	(C-47)	(C-53)
1 2 3 4	1 2 3 4	1 2 3 4	1 2 3 4 5 6 7 8 9 10 11 12 13 14 15 16 17 18 19 20 21 22 23 24 25 26	31 32 33 34 35 36 37 38 39 40 41 42 43 44 45 46	51 52 53 54 55 56 57 58 59 60 61 62 63 64 65 66 67 68 69 70 71 72



**ELC-4 A/T CIRCUIT (1994, 1995 MODELS)  
(FEDERAL)**

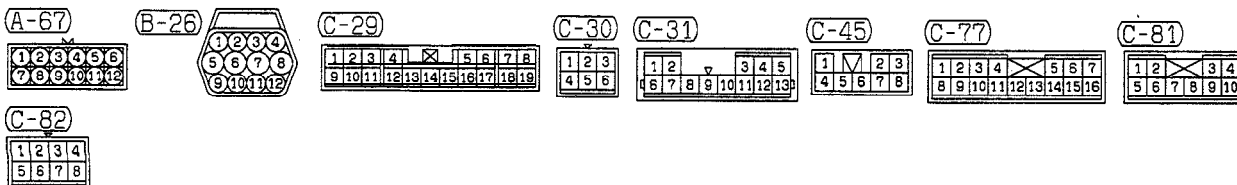
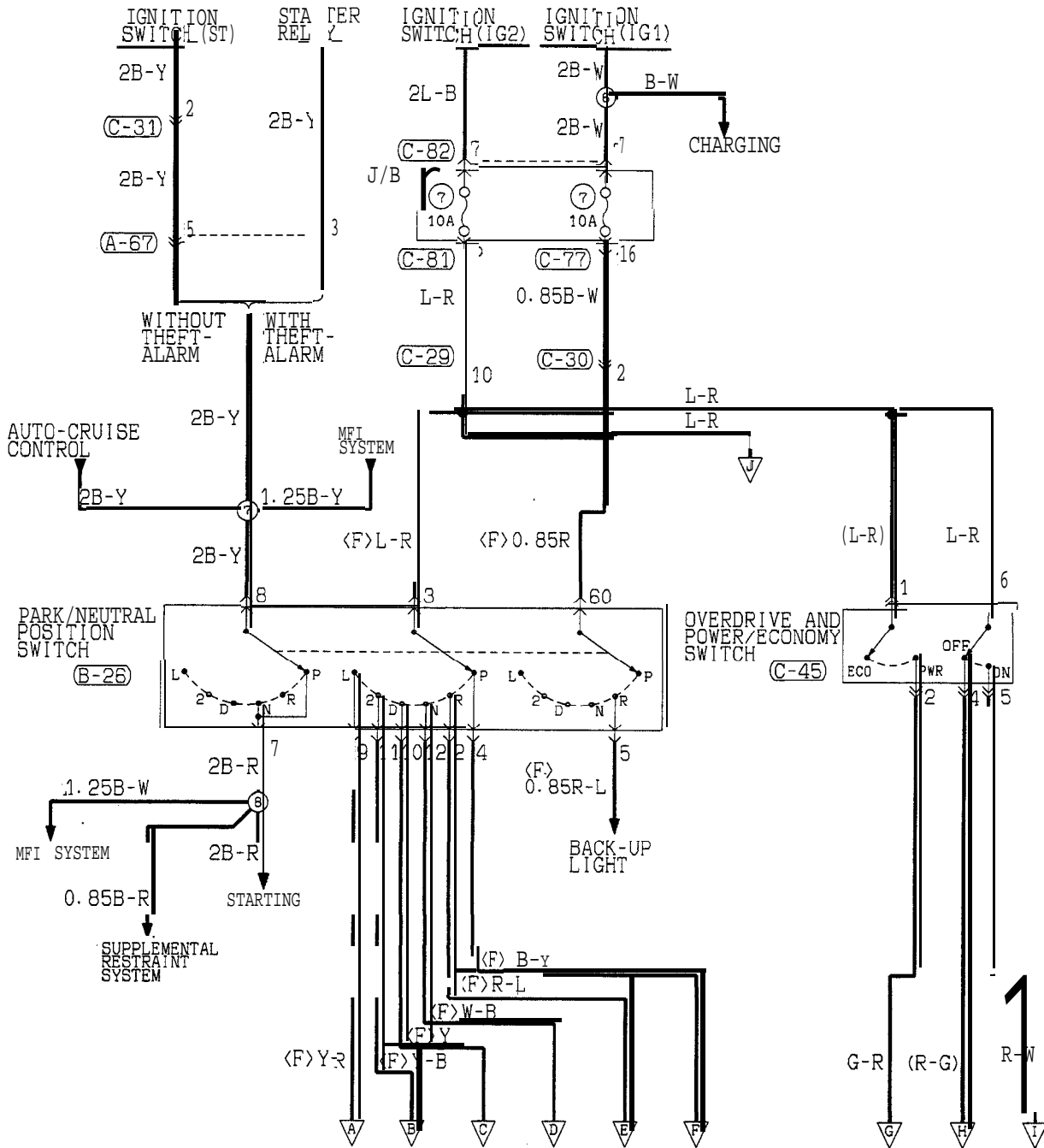

HR07M02AA

TSB Revision

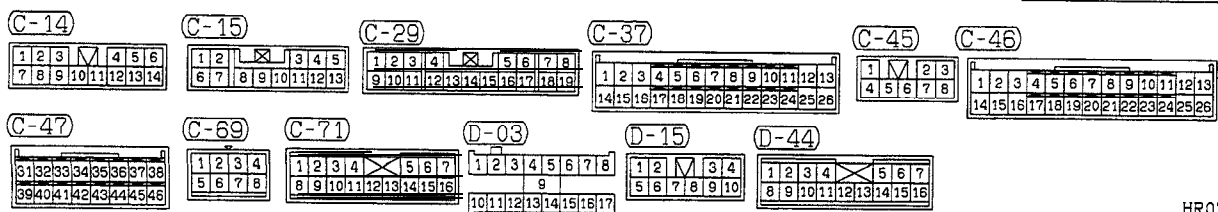
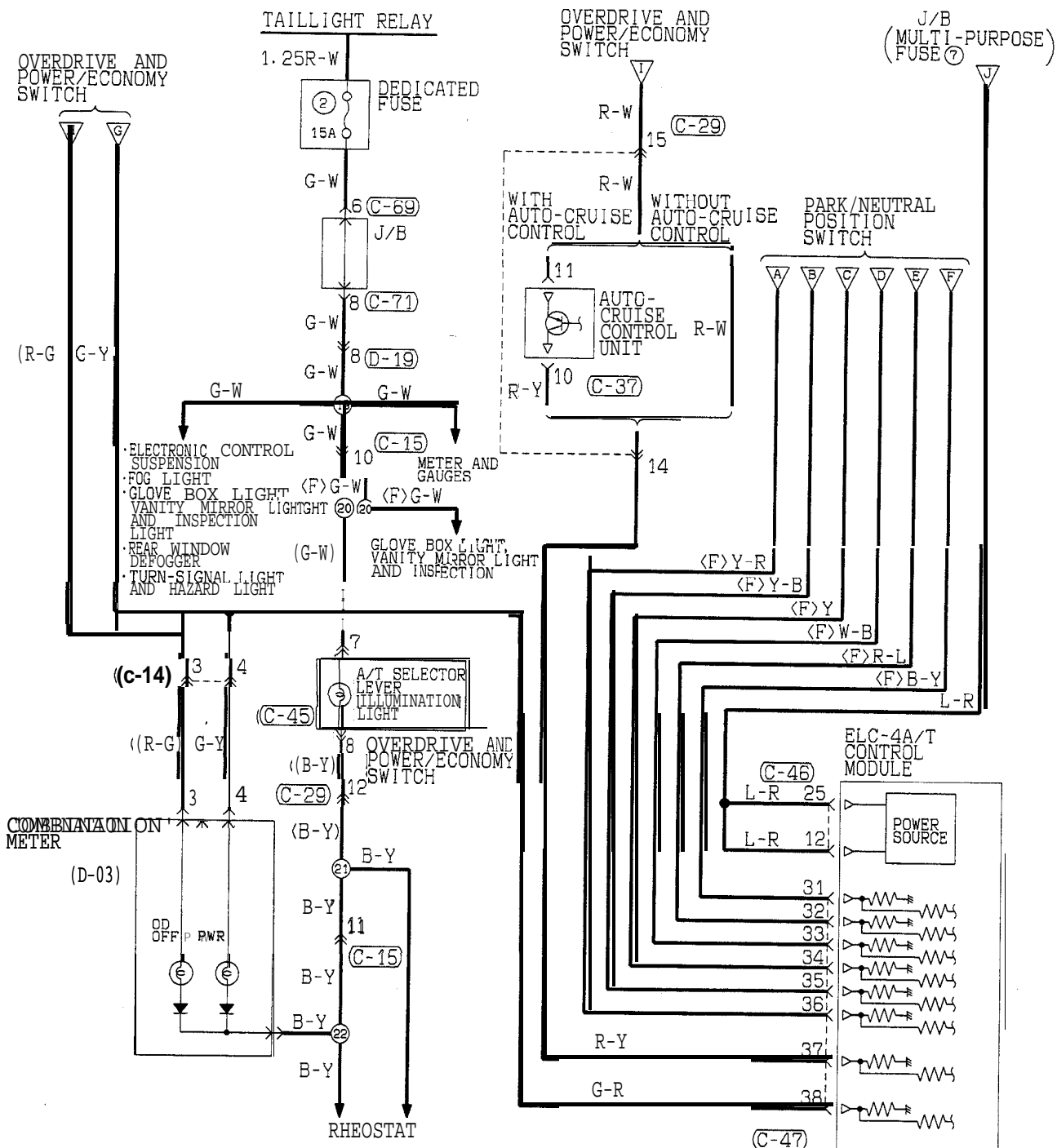

TSB Revision

ELC-4 A/T CIRCUIT (1994, 1995 MODELS) (FEDERAL) (CONTINUED)

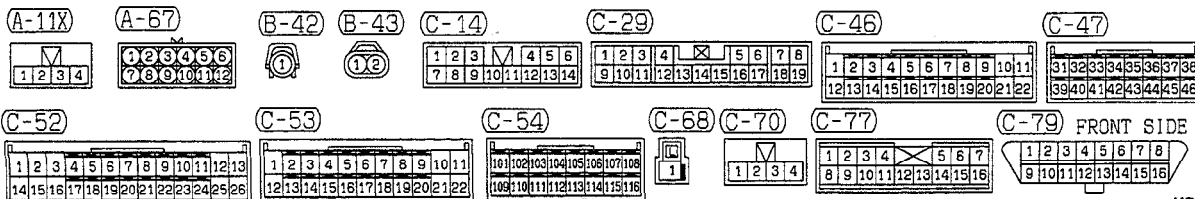
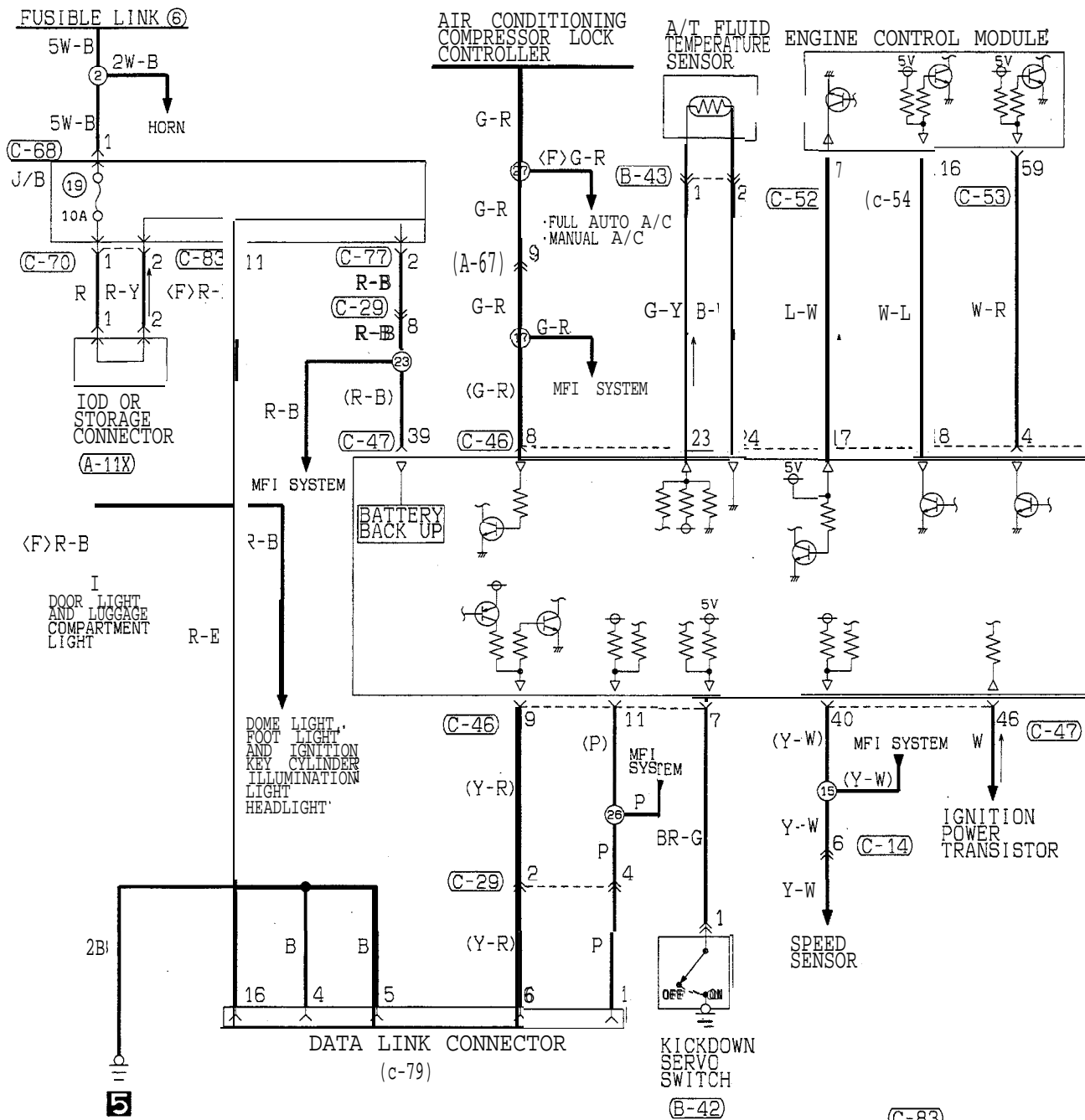

HR07M02BA

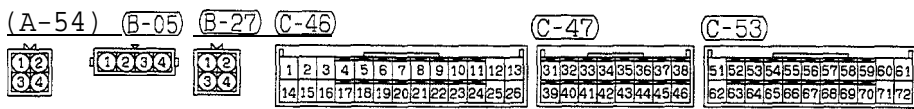
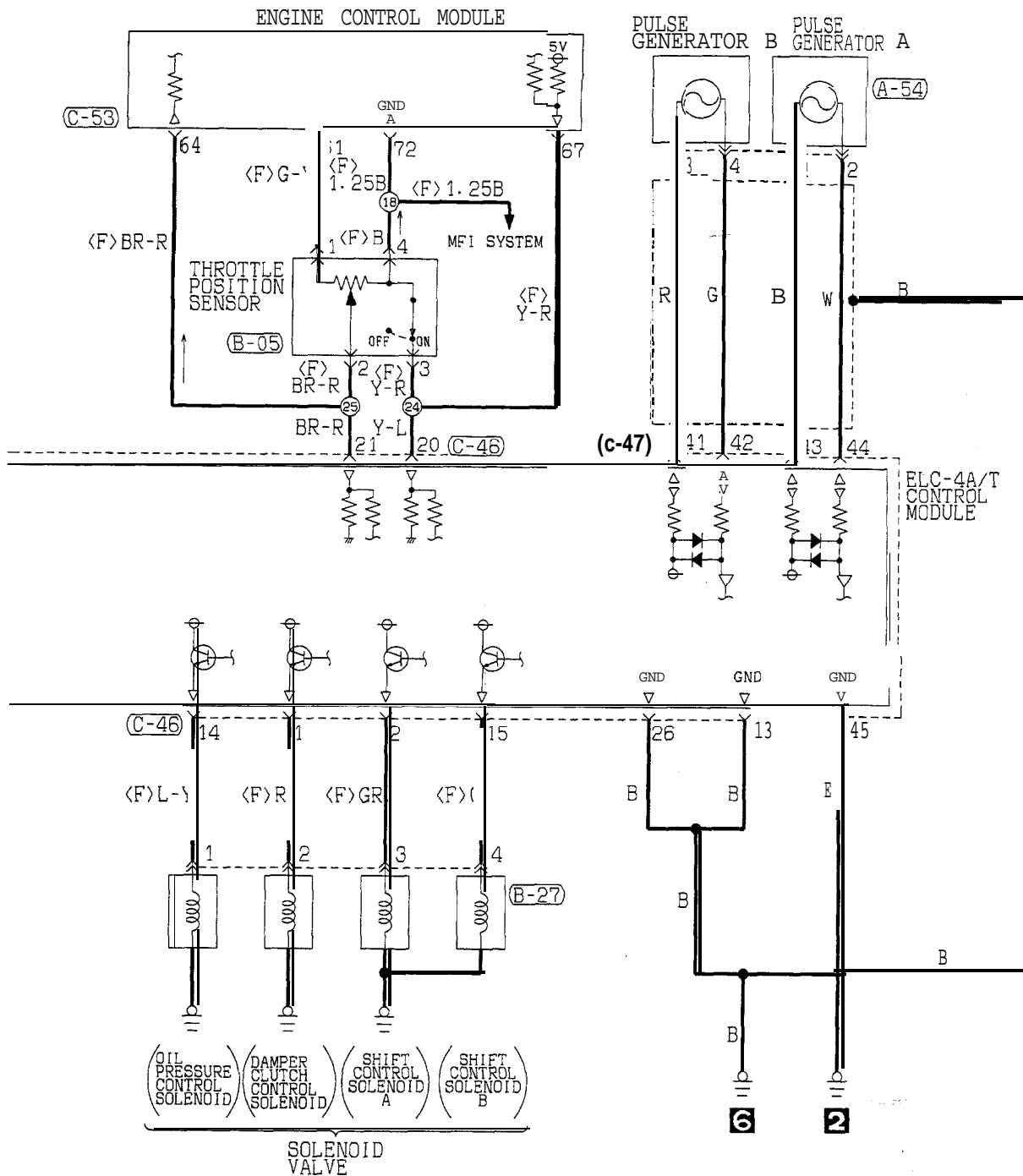

ELC-4 A/T CIRCUIT (1994, 1995 MODELS)  
(CALIFORNIA)

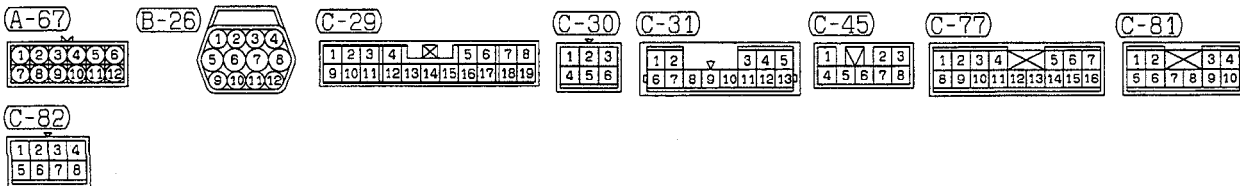
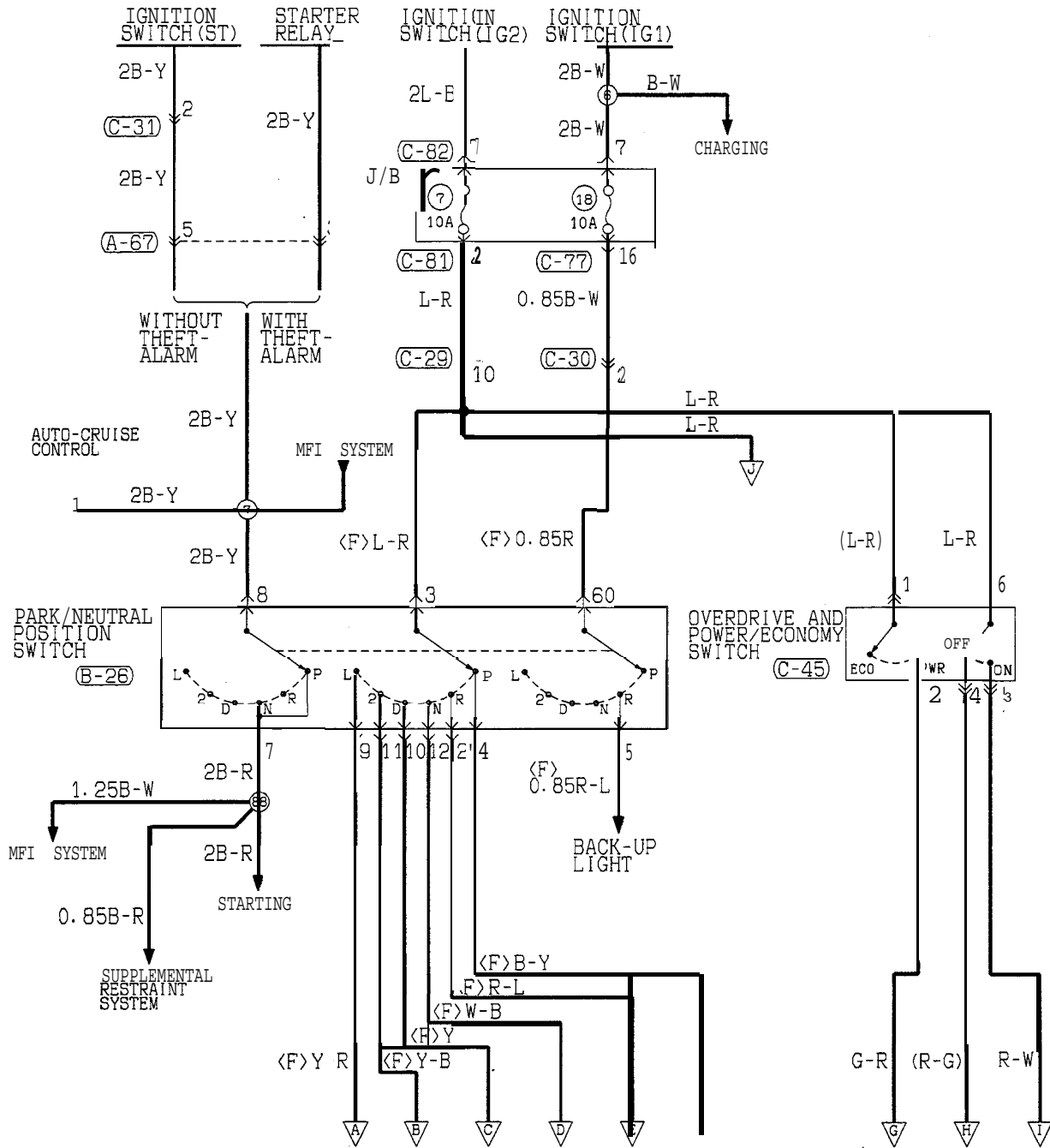

HR07M03AA

TSB Revision

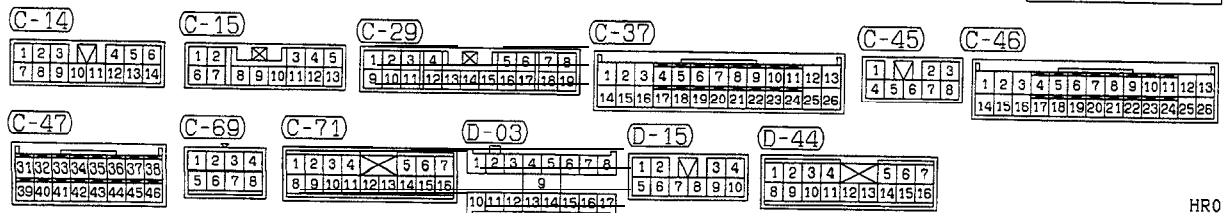
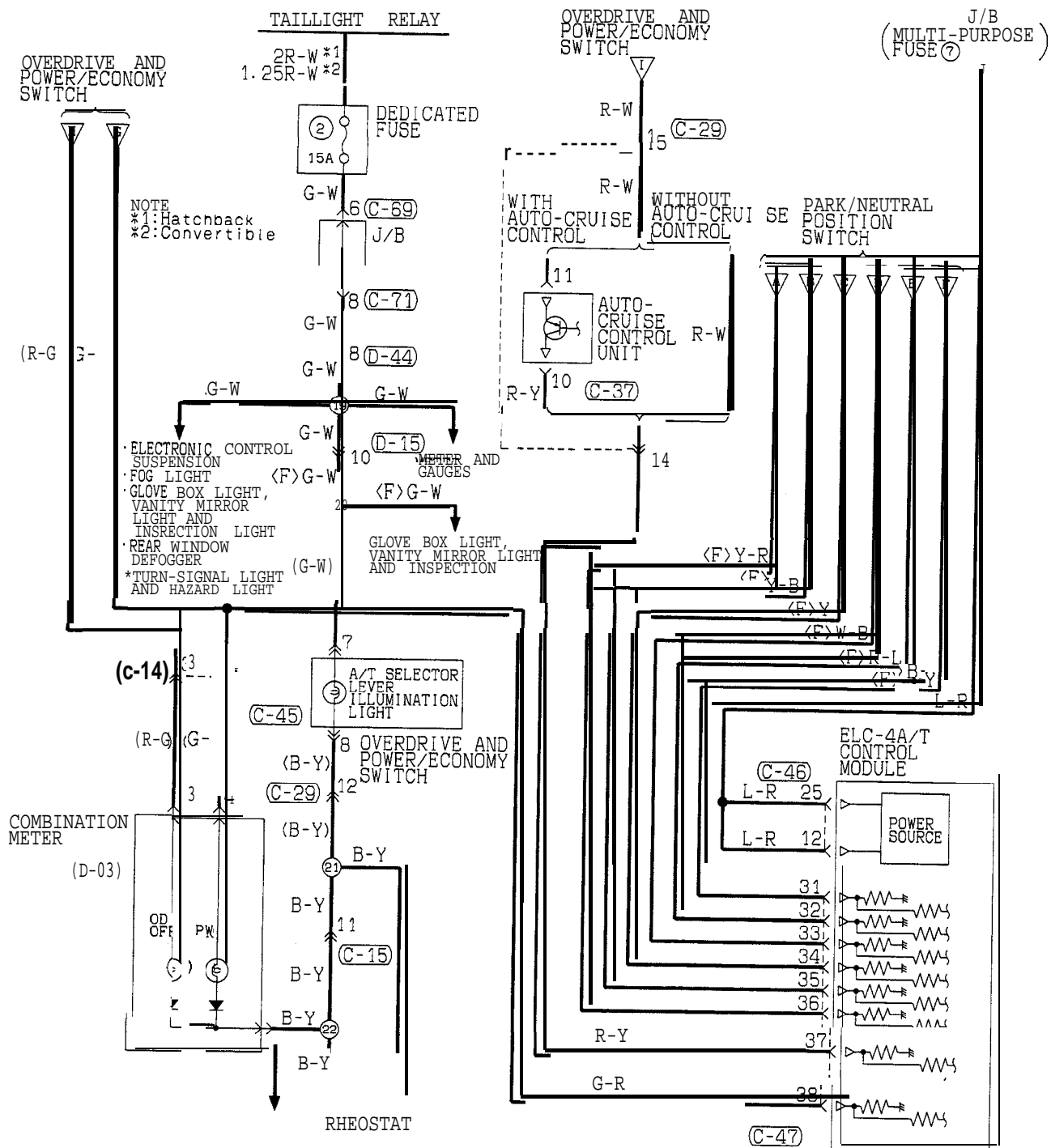

TSB Revision

ELC-4 A/T CIRCUIT (1994, 1995 MODELS) (CALIFORNIA) (CONTINUED)

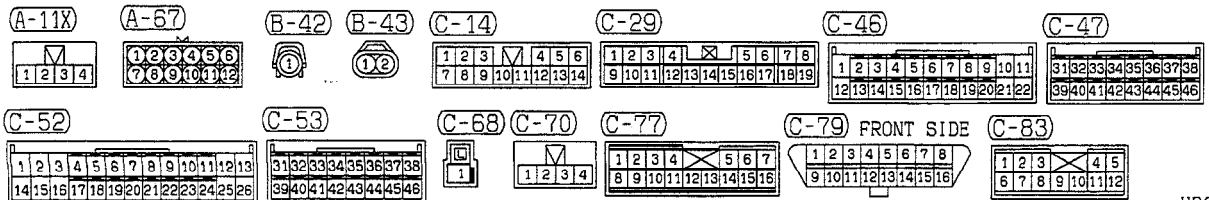
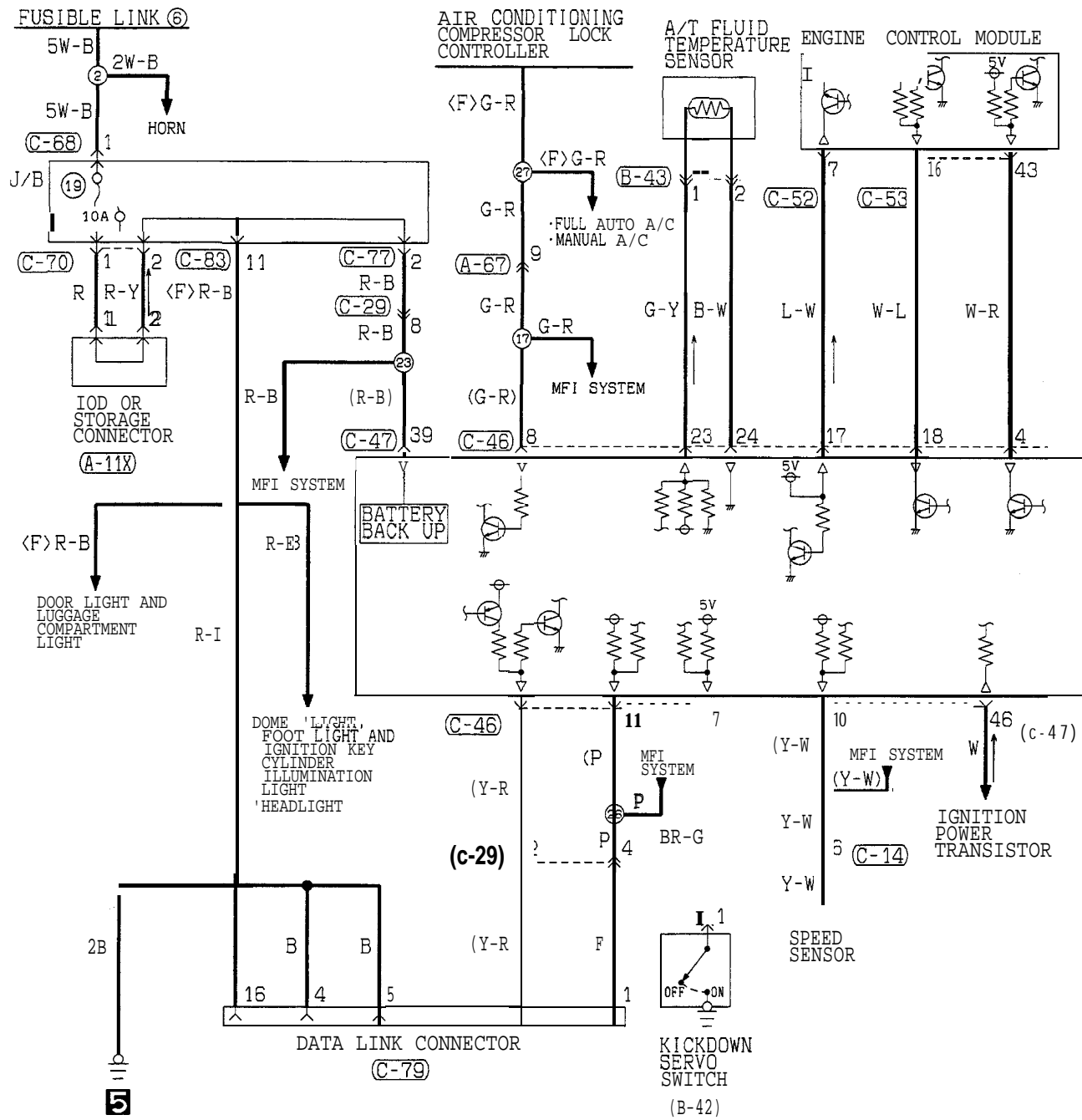

HR07M0 3BA

TSB Revision

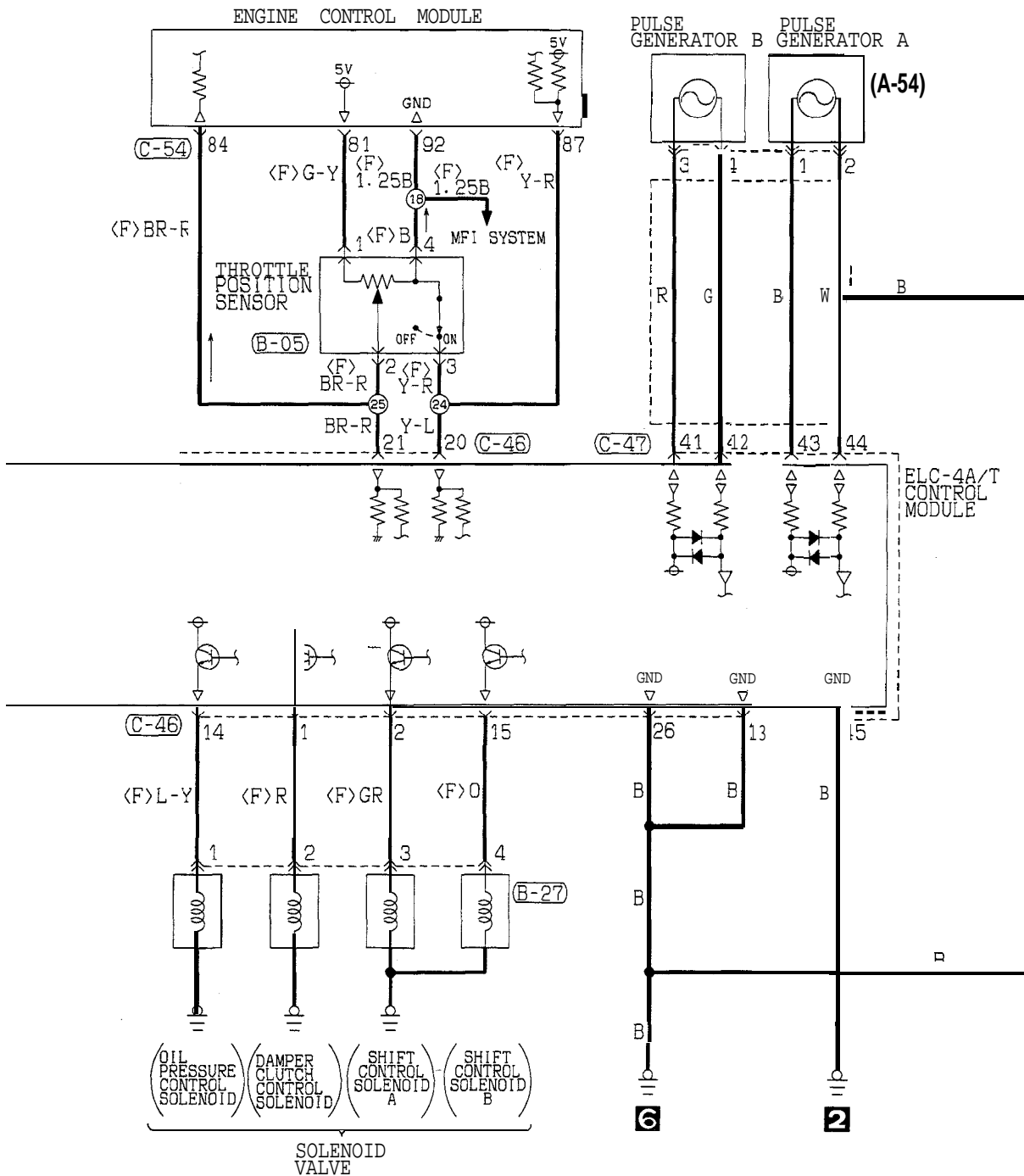

<b>A-54</b>	<b>B-05</b>	<b>B-27</b>	<b>C-46</b>	<b>C-47</b>	<b>C-54</b>
1 2 3 4	1 2 3 4	1 2 3 4	1 2 3 4 5 6 7 8 9 10 11 12 13 14 15 16 17 18 19 20 21 22 23 24 25 26	31 32 33 34 35 36 37 38 39 40 41 42 43 44 45 46	71 72 73 74 75 76 77 78 79 80 81 82 83 84 85 86 87 88 89 90 91 92

TSB Revision



ELC-4 A/T CIRCUIT (FROM 1996 MODELS)

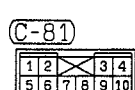
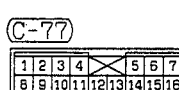
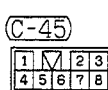
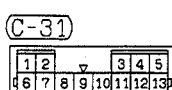
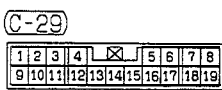
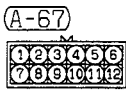
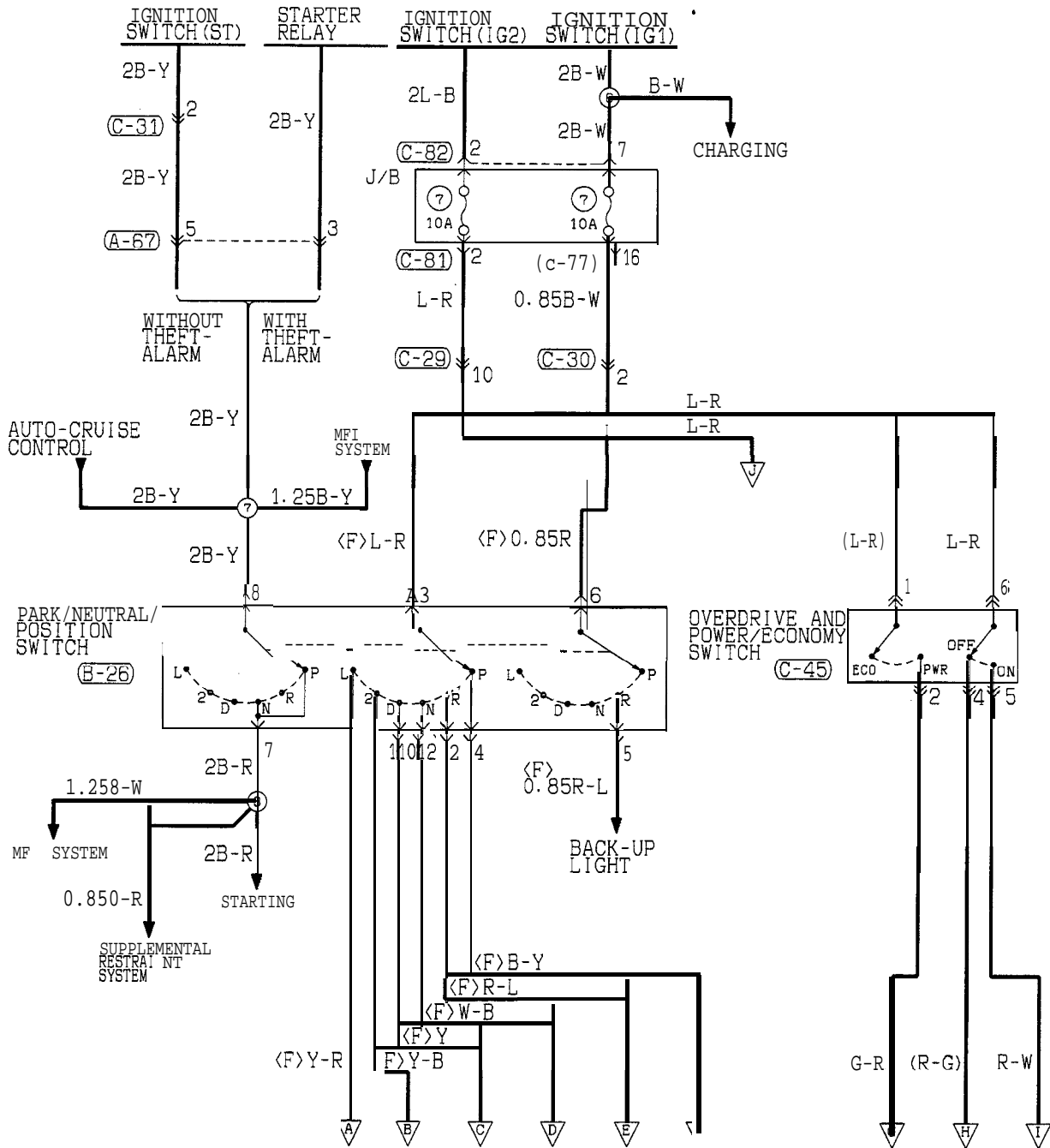

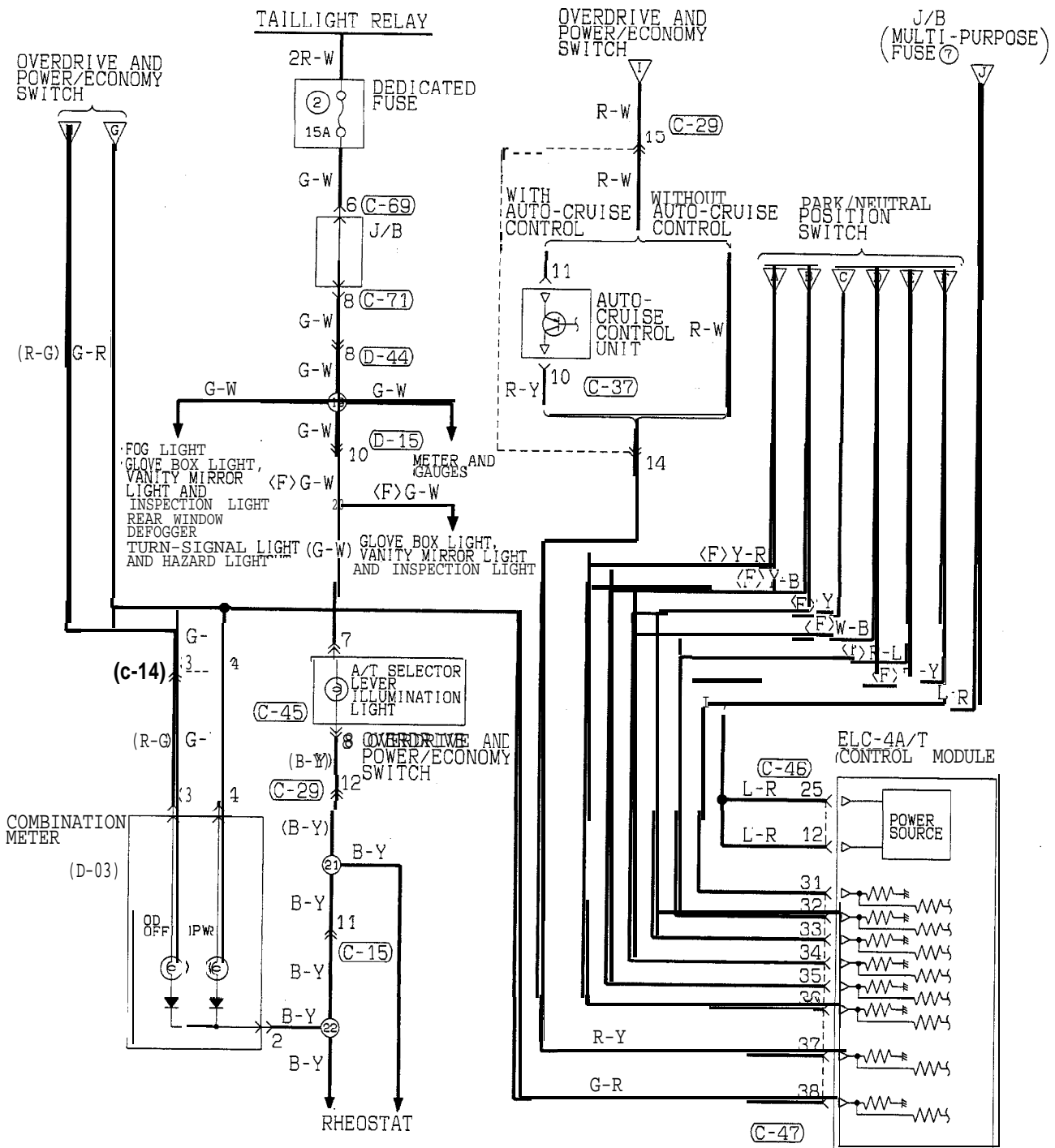

C-14

1	2	3	4	5	6
7	8	9	10	11	12
13	14				

C-15

1	2	3	4	5
6	7	8	9	10
11	12	13		

C-29

1	2	3	4	5	6	7	8
9	10	11	12	13	14	15	16
17	18	19					

C-37

1	2	3	4	5	6	7	8	9	10	11	12	13
14	15	16	17	18	19	20	21	22	23	24	25	26

C-45

1	2	3
4	5	6
7	8	

C-46

1	2	3	4	5	6	7	8	9	10	11	12	13
14	15	16	17	18	19	20	21	22	23	24	25	26

C-47

31	32	33	34	35	36	37	38
39	40	41	42	43	44	45	46

C-69

1	2	3	4
5	6	7	8

C-71

1	2	3	4	5	6	7
8	9	10	11	12	13	14
15	16					

D-03

1	2	3	4	5	6	7	8
9							
10	11	12	13	14	15	16	17

D-15

1	2	3	4
5	6	7	8
9	10		

D-44

1	2	3	4	5	6	7
8	9	10	11	12	13	14
15	16					

TSB Revision

ELC-4 A/T CIRCUIT (FROM 1996 MODELS) (CONTINUED)

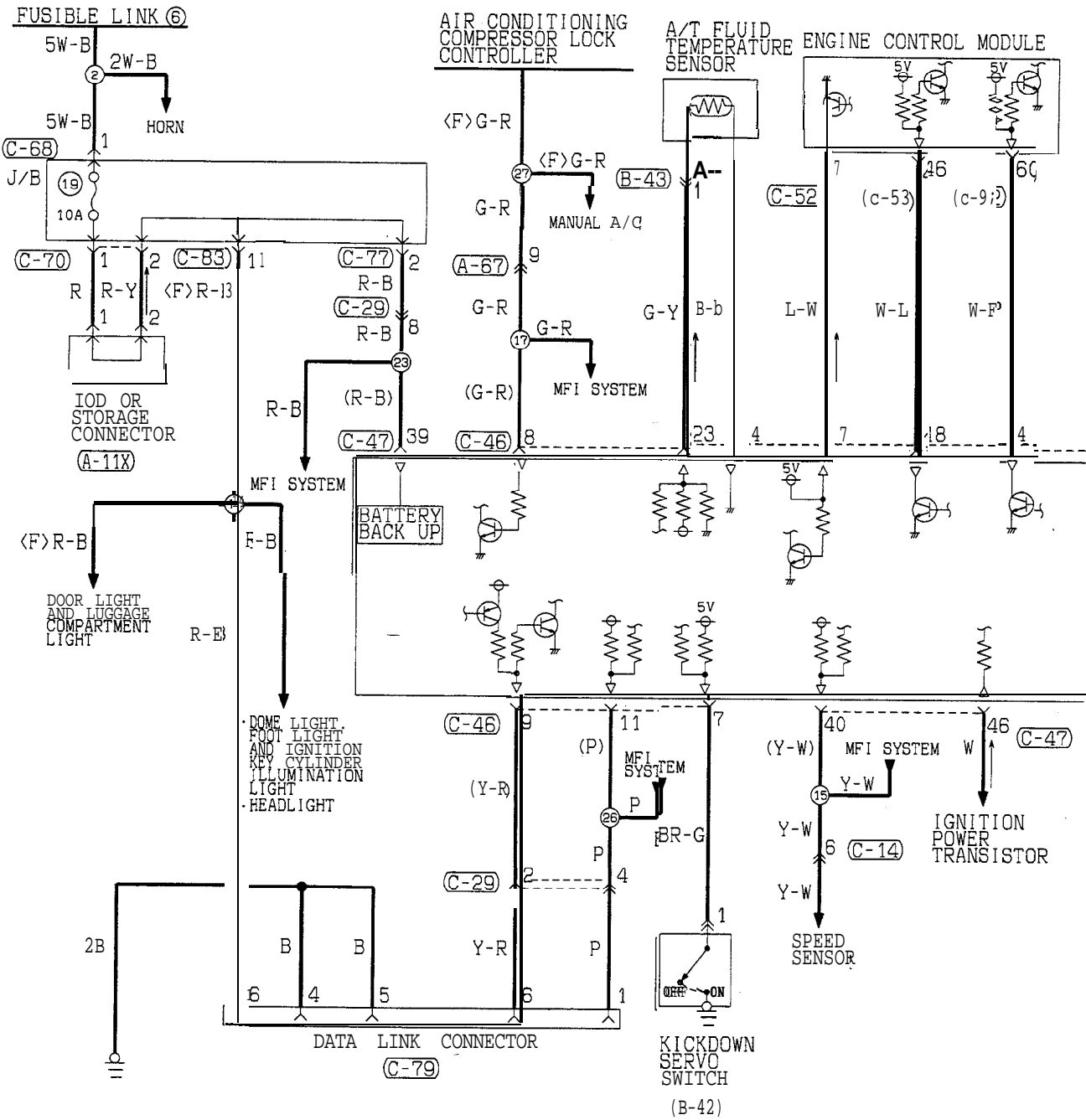

<b>A-11X</b> 1 2 3 4	<b>A-67</b> 1 2 3 4 5 6 7 8 9 10 11 12	<b>B-42</b> 1	<b>B-43</b> 1 2	<b>C-14</b> 1 2 3 4 5 6 7 8 9 10 11 12 13 14	<b>C-29</b> 1 2 3 4 5 6 7 8 9 10 11 12 13 14 15 16 17 18 19	<b>C-46</b> 1 2 3 4 5 6 7 8 9 10 11 12 13 14 15 16 17 18 19 20 21 22	<b>C-47</b> 31 32 33 34 35 36 37 38 39 40 41 42 43 44 45 46	<b>C-52</b> 1 2 3 4 5 6 7 8 9 10 11 14 15 16 17 18 19 20 21 22 23 24 25 26
<b>C-53</b> 1 2 3 33 34 35 36 37 38 39 40 41 42 43 44 45 46	<b>C-68</b> 1	<b>C-70</b> 1 2 3 4	<b>C-77</b> 1 2 3 4 5 6 7 8 9 10 11 12 13 14 15 16	<b>C-79 FRONT SIDE</b> 1 2 3 4 5 6 7 8 9 10 11 12 13 14 15 16	<b>C-83</b> 1 2 3 4 5	<b>C-92</b> 1 2 3 4 5 6 51 52 53 24 55 56 57 58 59 60 61 62		

TSB Revision

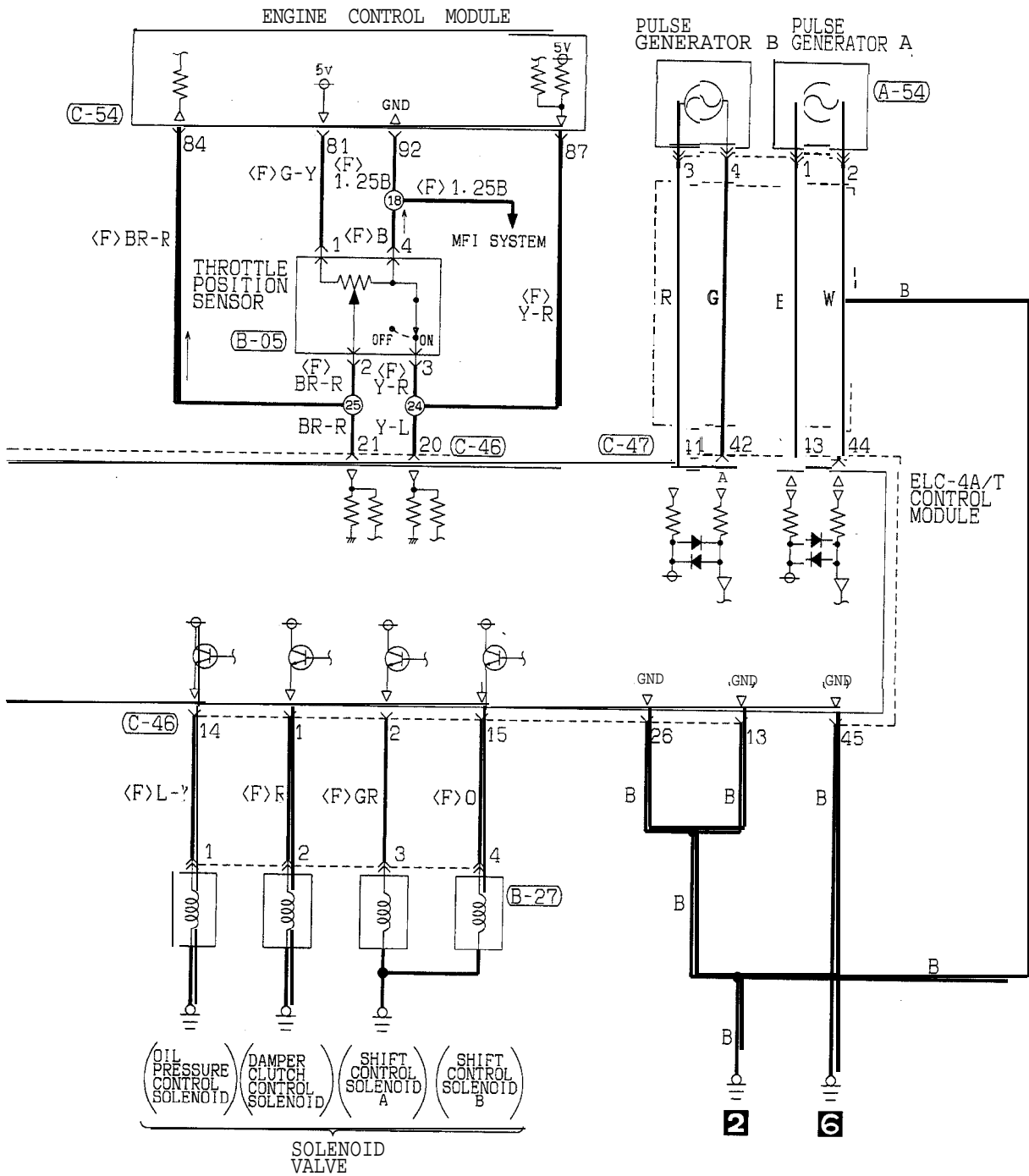

<b>A-54</b>	<b>B-05</b>	<b>B-27</b>	<b>C-46</b>	<b>C-47</b>	<b>C-54</b>
12 34	1234	12 34	1 2 3 4 5 6 7 8 9 10 11 12 13 14 15 16 17 18 19 20 21 22 23 24 25 26	31 32 33 34 35 36 37 38 39 40 41 42 43 44 45 46	JAF 71 72 73 74 75 76 77 78 79 80 81 82 83 84 85 86 87 88 89 90 91 92

COMPONENT LOCATION

Name	Symbol	Name	Symbol
A/T fluid temperature sensor	A	ELC-4 A/T control module	F
A/T solenoid valve assembly (valve body)	B	Engine control module	D
Auto-cruise control unit	G	Kickdown servo switch	A
Data link connector (from 1994 models)	E	Pulse generator	A
Data link connector (up to 1993 models)	D	Throttle position sensor	C

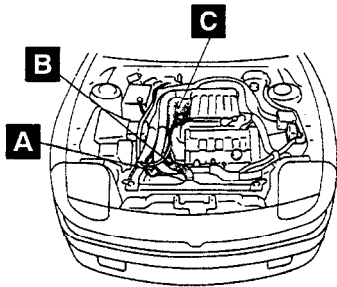

T16F0257

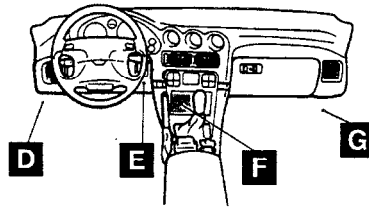

Q19F0134  
00002686

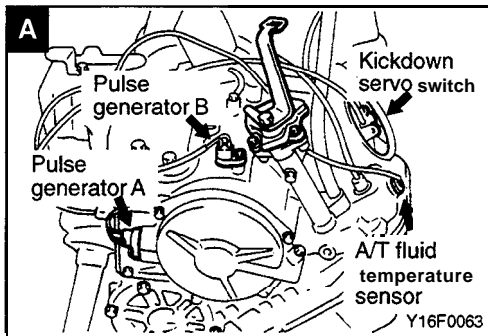

Y16F0063

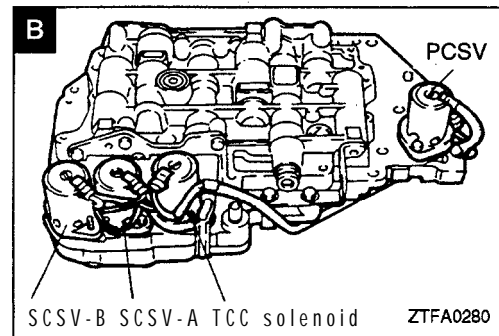

ZTFA0280

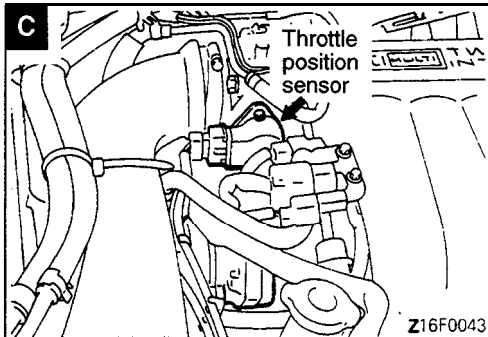

Z16F0043

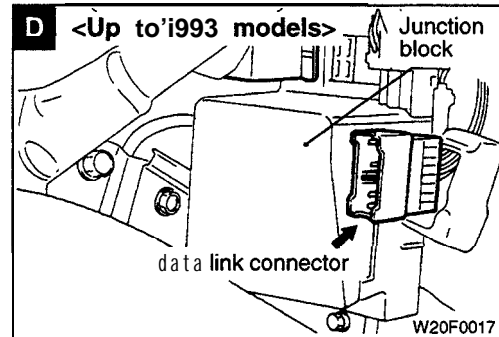

W20F0017

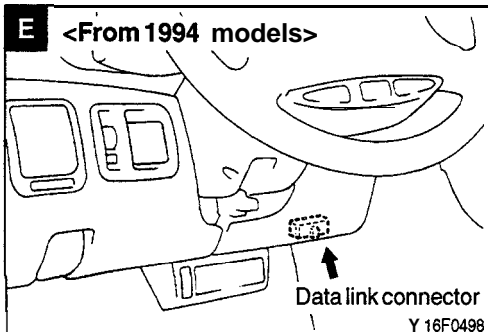

Y16F0498

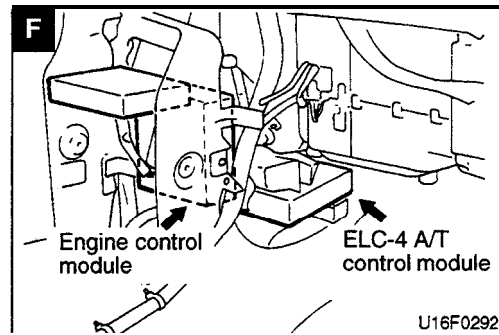

U16F0292

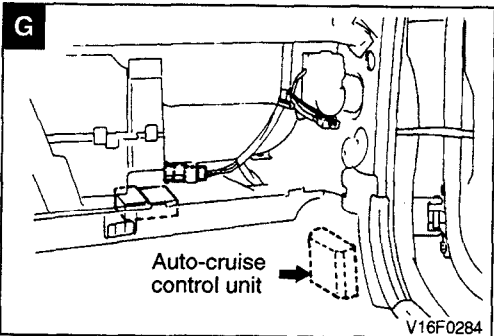

BUZZER CIRCUIT (UP TO 1993 MODELS)

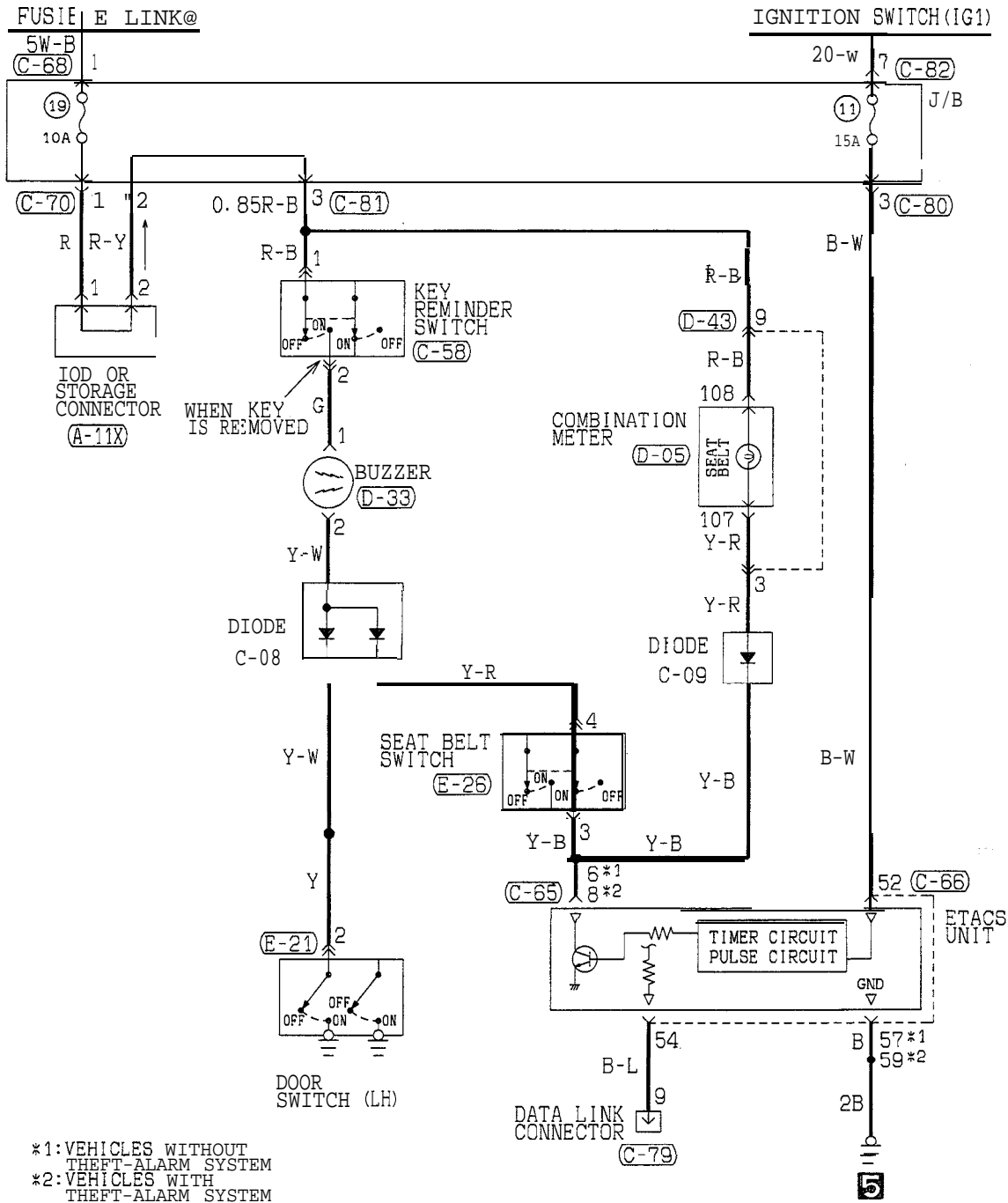

\*1: VEHICLES WITHOUT THEFT-ALARM SYSTEM  
 \*2: VEHICLES WITH THEFT-ALARM SYSTEM

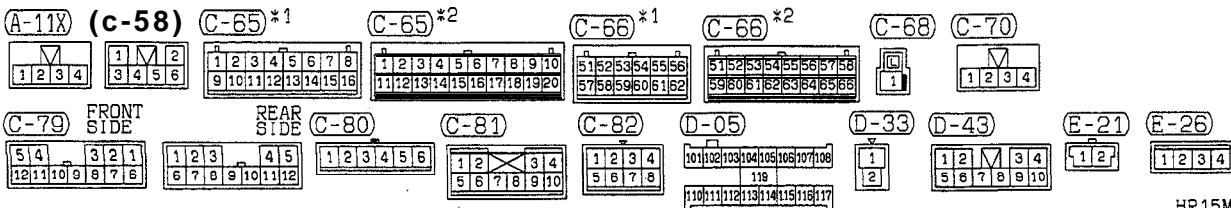

HR15M03AA

**BUZZER CIRCUIT (FROM 1994 MODELS)**

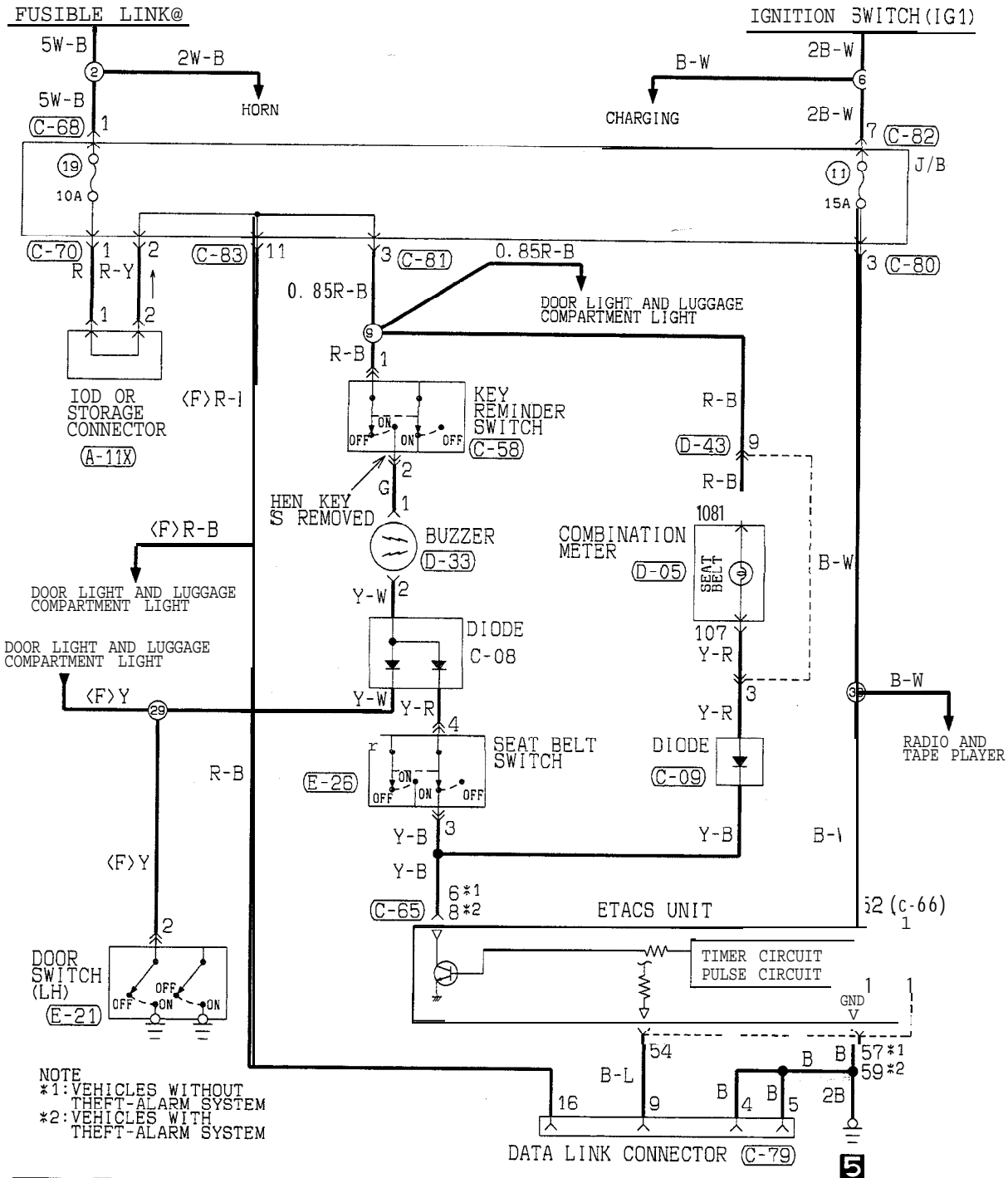

NOTE  
 \*1: VEHICLES WITHOUT THEFT-ALARM SYSTEM  
 \*2: VEHICLES WITH THEFT-ALARM SYSTEM

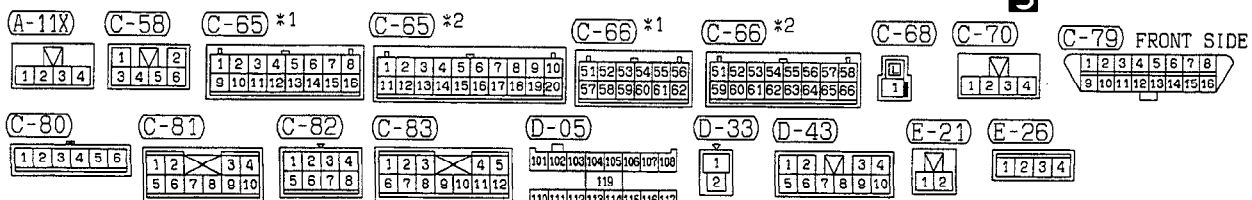

TSB Revision



COMPONENT LOCATION

Name	Symbol	Name	Symbol
Buzzer	C	ETACS unit	A
Diode (seat belt warning)	B		

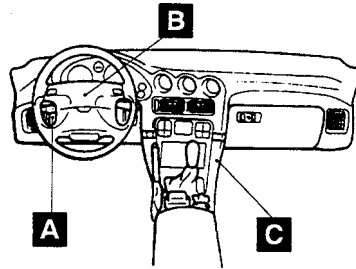

P19F0134

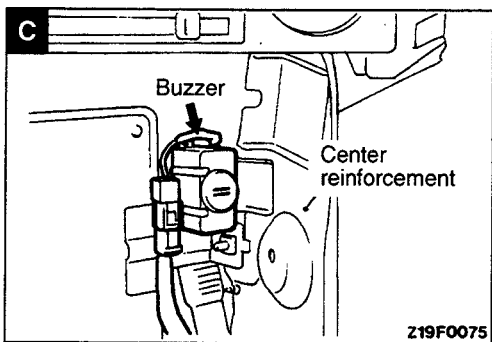
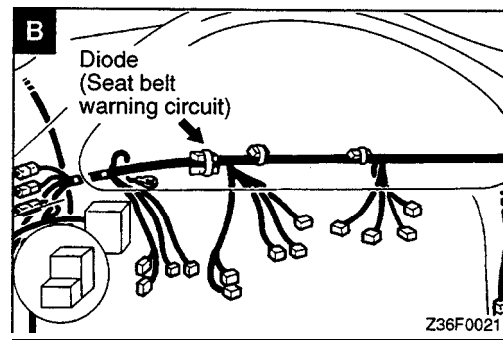
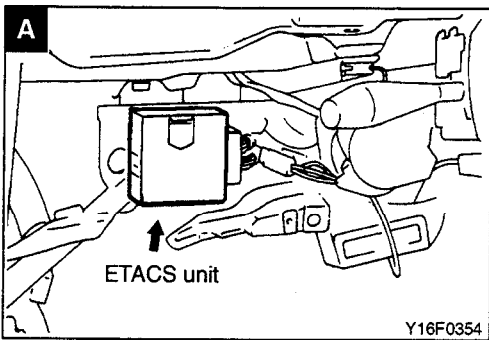

**OPERATION**

**<Key-reminder warning>**

- Battery positive voltage is continuously applied to the key-reminder switch.
- If the driver's door is opened (door switch ON) with the key inserted in the ignition switch (key-reminder switch ON), the buzzer sounds to warn that the key has been left in the switch.

**<Seat belt warning>**

- When the ignition switch is turned on, the timer circuit and pulse circuit will flicker the seat belt warning light for approx. 6 seconds with the buzzer intermittently sounding.
- If the seat belt is fastened for the while, the seat belt switch will be turned off and the buzzer will stop.

**TROUBLESHOOTING HINTS**

Problem		Check method
The key-reminder warning doesn't sound.	The seat belt warning function is OK.	<ul style="list-style-type: none"> <li>• Check the door switch. (Refer to GROUP 42–Door Assembly.)</li> </ul>
	The seat belt warning also doesn't function.	<ul style="list-style-type: none"> <li>• Check the buzzer. (Refer to GROUP 52A–Seat Belt.)</li> </ul>
The seat belt warning doesn't function.	The seat belt warning light flashes.	<ul style="list-style-type: none"> <li>• Check the seat belt switch. (Refer to GROUP 52A–Seat Belt.)</li> </ul>
	The seat belt warning light also does not function (and the key-reminder warning also does not function).	<ul style="list-style-type: none"> <li>• Check the key-reminder switch. (Refer to GROUP M–Ignition Switch.)</li> </ul>
The buzzer doesn't stop even through the driver's seat belt has been buckled.		<ul style="list-style-type: none"> <li>• Check the seat belt switch. (Refer to GROUP 52A–Seat Belt.)</li> </ul>
The seat belt warning light doesn't flashes (but the buzzer sounds).		<ul style="list-style-type: none"> <li>• Check the light bulb.</li> <li>• Check the key-reminder switch. (Refer to GROUP 54–Ignition Switch.)</li> <li>• Check the seat belt switch. (Refer to GROUP 52A–Seat Belt.)</li> </ul>
The warning light does not flash and the warning buzzer also does not sound.		<ul style="list-style-type: none"> <li>• Check the ignition switch input signal. (Refer to GROUP 52A–Troubleshooting.)</li> <li>• Check the key-reminder switch. (Refer to GROUP 54–Ignition Switch.)</li> <li>• Check the seat belt switch. (Refer to GROUP 52A–Seat Belt.)</li> </ul>
The warning light flashes, but the warning buzzer does not sound.		<ul style="list-style-type: none"> <li>• Check the key-reminder switch. (Refer to GROUP M–Ignition Switch.)</li> <li>• Check the seat belt switch. (Refer to GROUP 52A–Seat Belt.)</li> </ul>

**POWER WINDOW CIRCUIT  
(UP TO 1993 MODELS)**

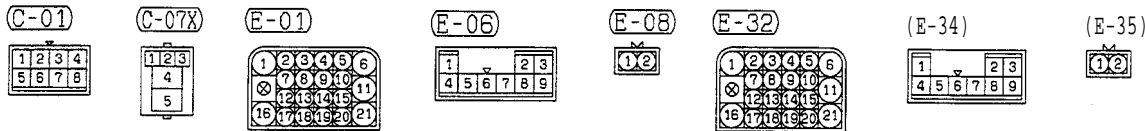
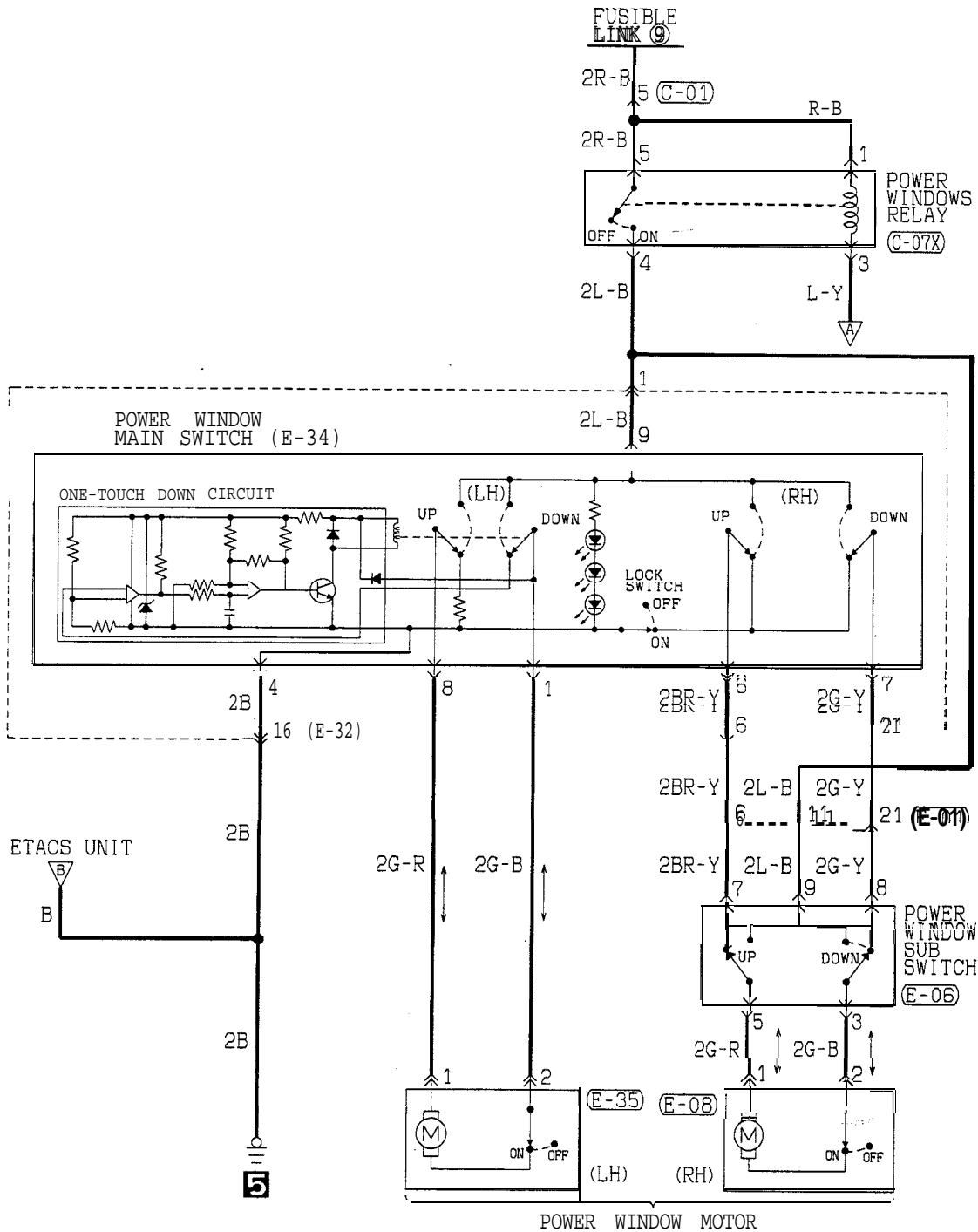

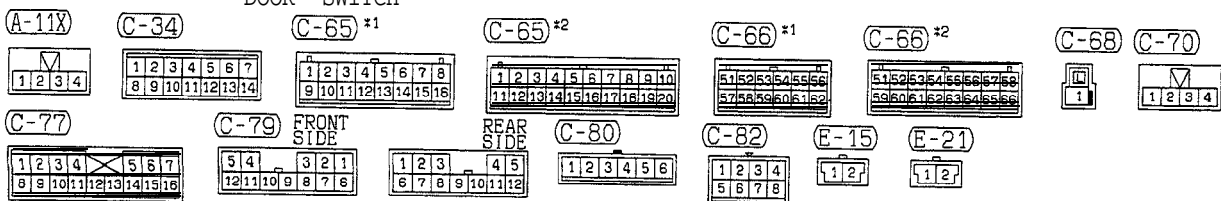
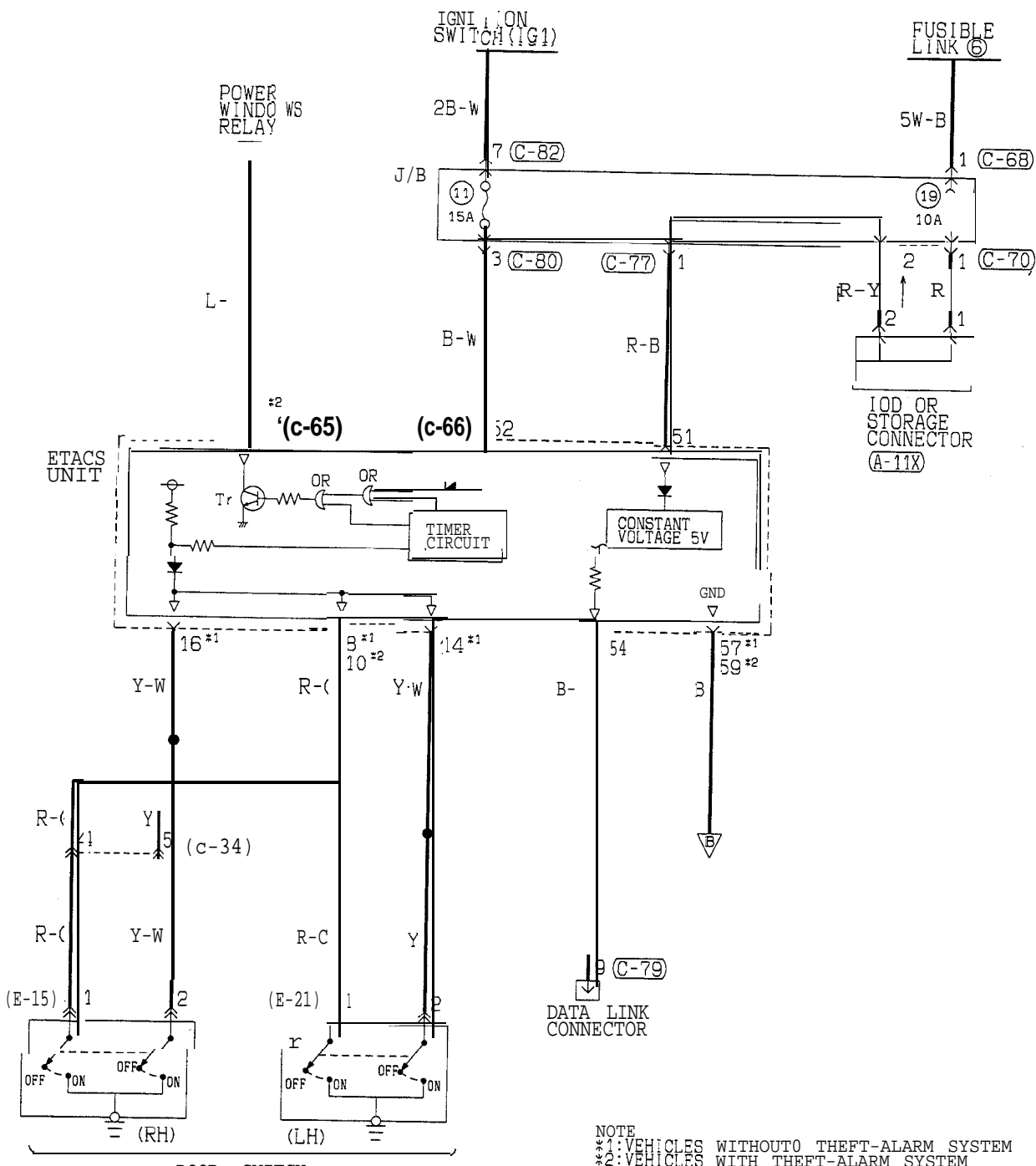

TSB Revision

**POWER WINDOW CIRCUIT  
(1994 MODELS)**

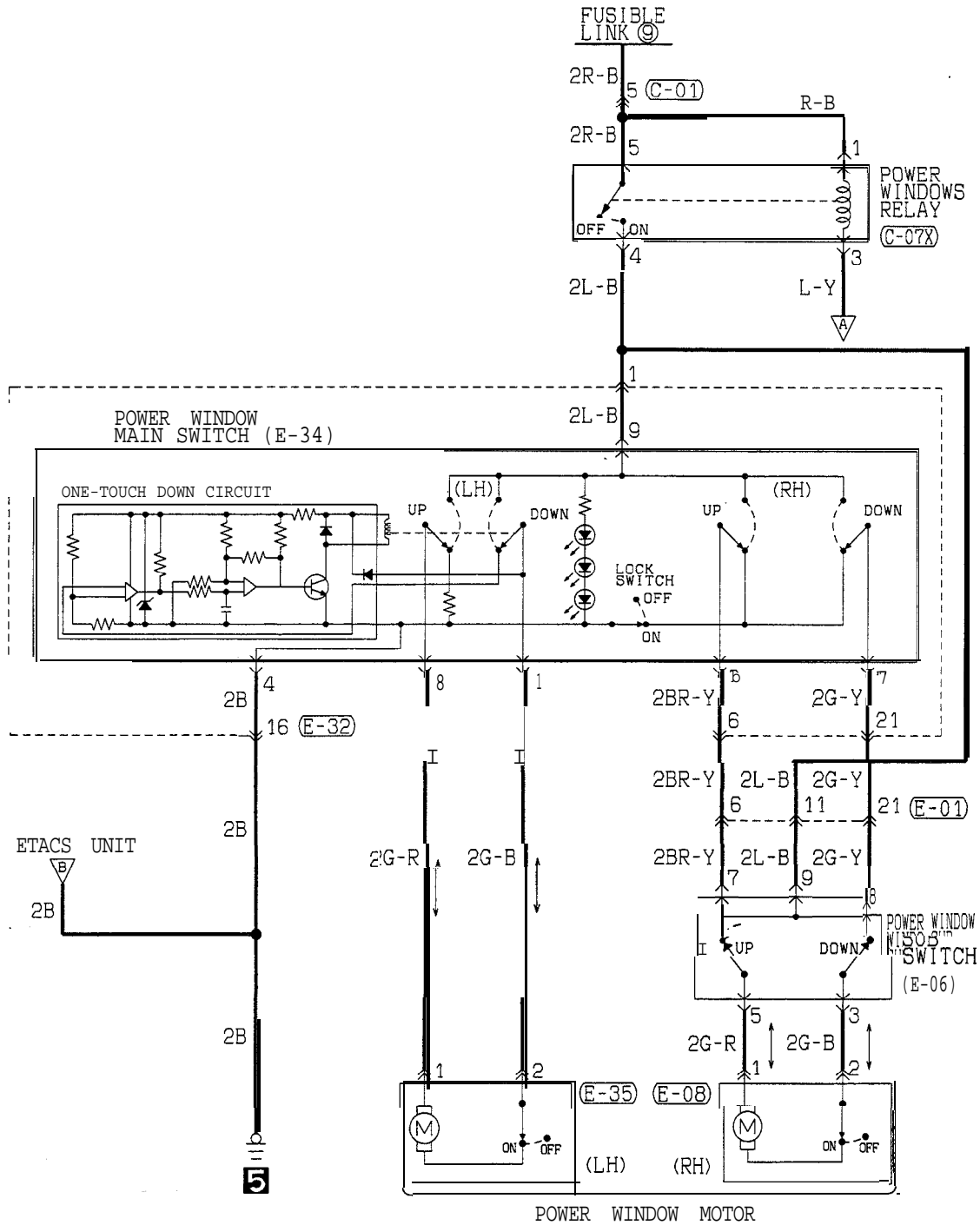

(C-01)



(C-07X)



(E-01)

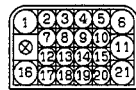

(E-06)

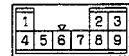

(E-08)



(E-32)

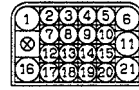

(E-34)

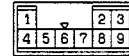

(E-35)



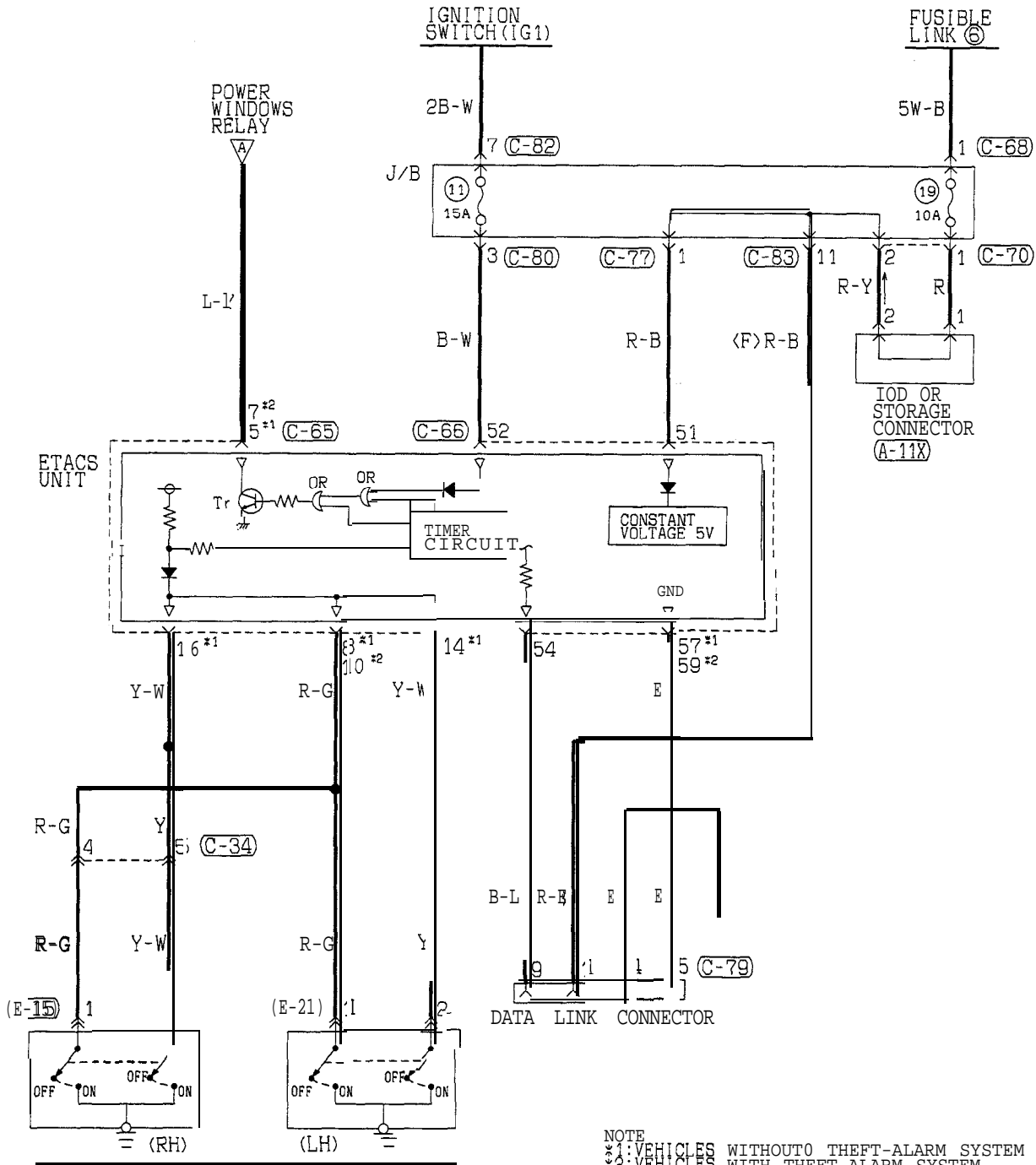

NOTE  
 \*1: VEHICLES WITHOUTO THEFT-ALARM SYSTEM  
 \*2: VEHICLES WITH THEFT-ALARM SYSTEM

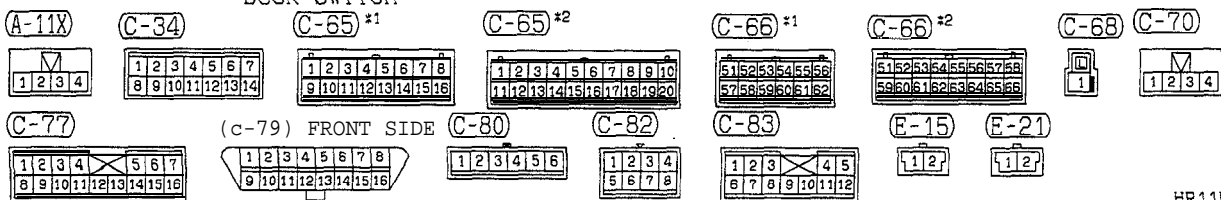

HR11M01AB

**POWER WINDOW- CIRCUIT  
(1995 MODELS)**

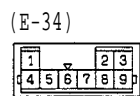
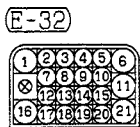
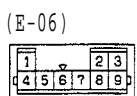
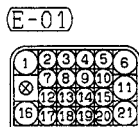
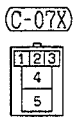
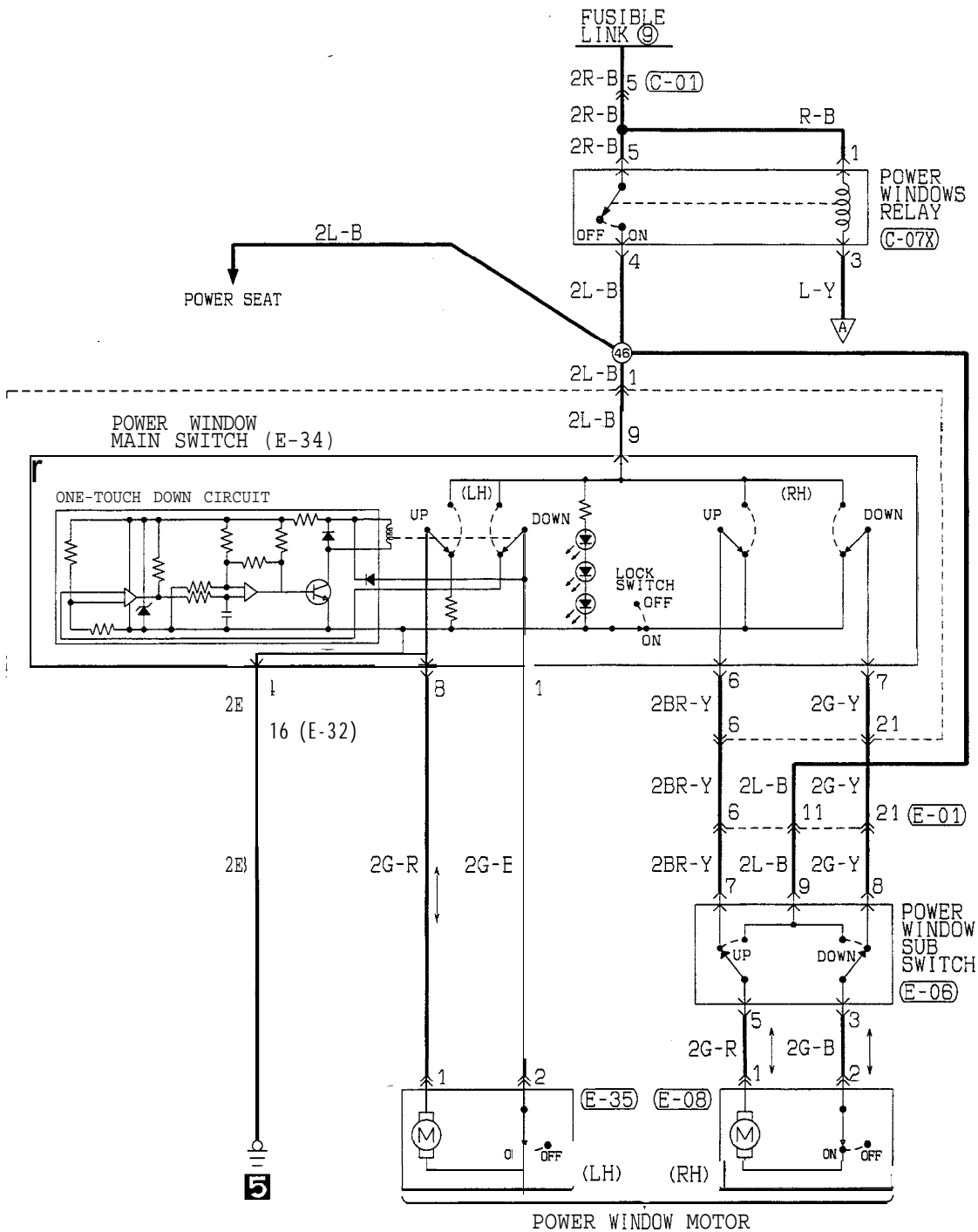

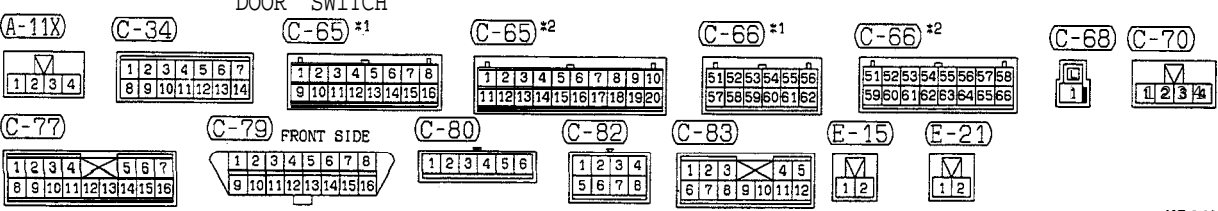
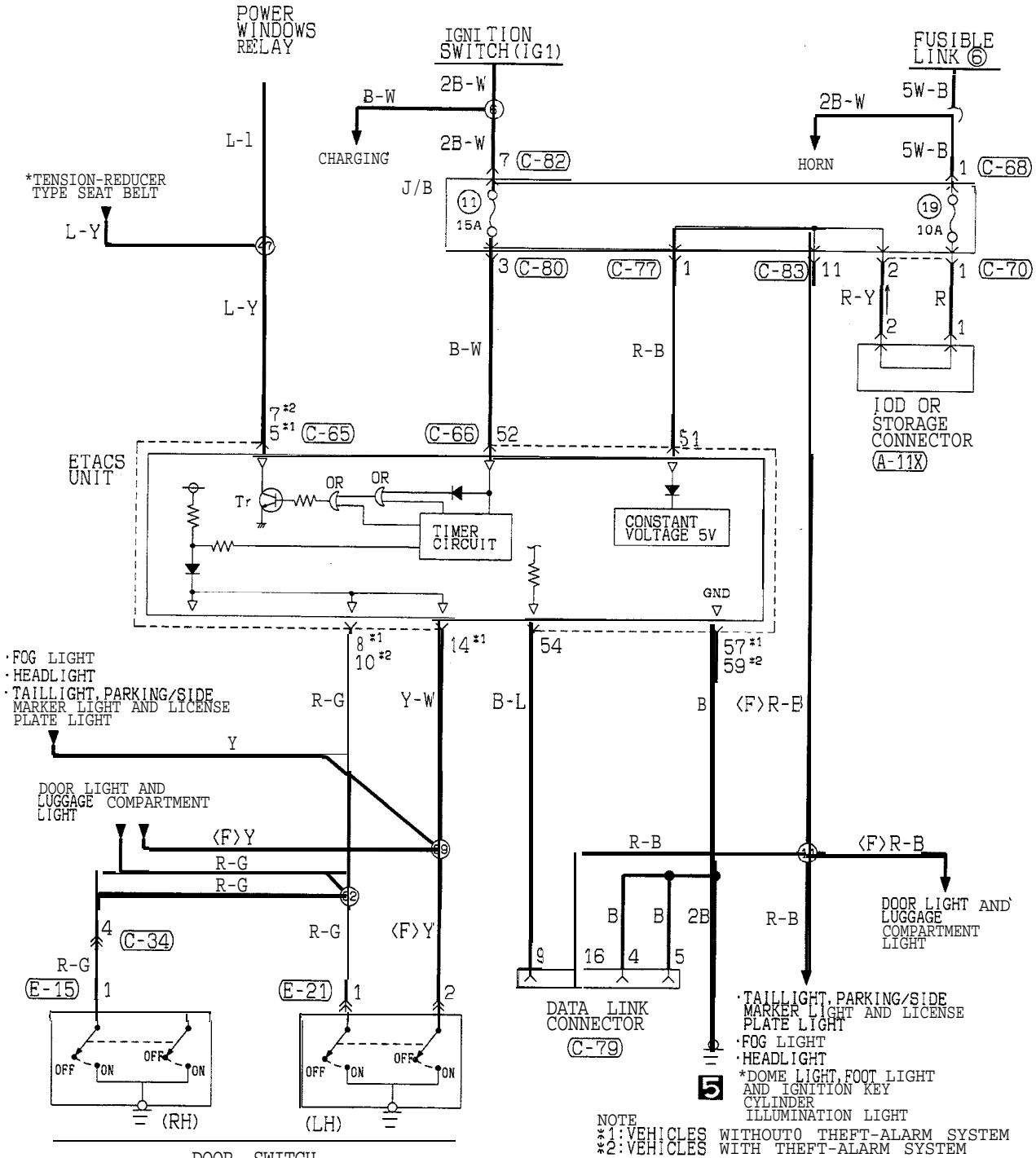

TSB Revision



**POWER WINDOW CIRCUIT  
(FROM 1996 MODELS)**

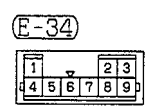
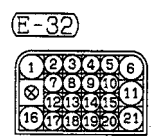
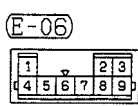
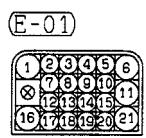
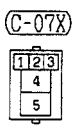
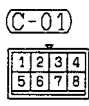
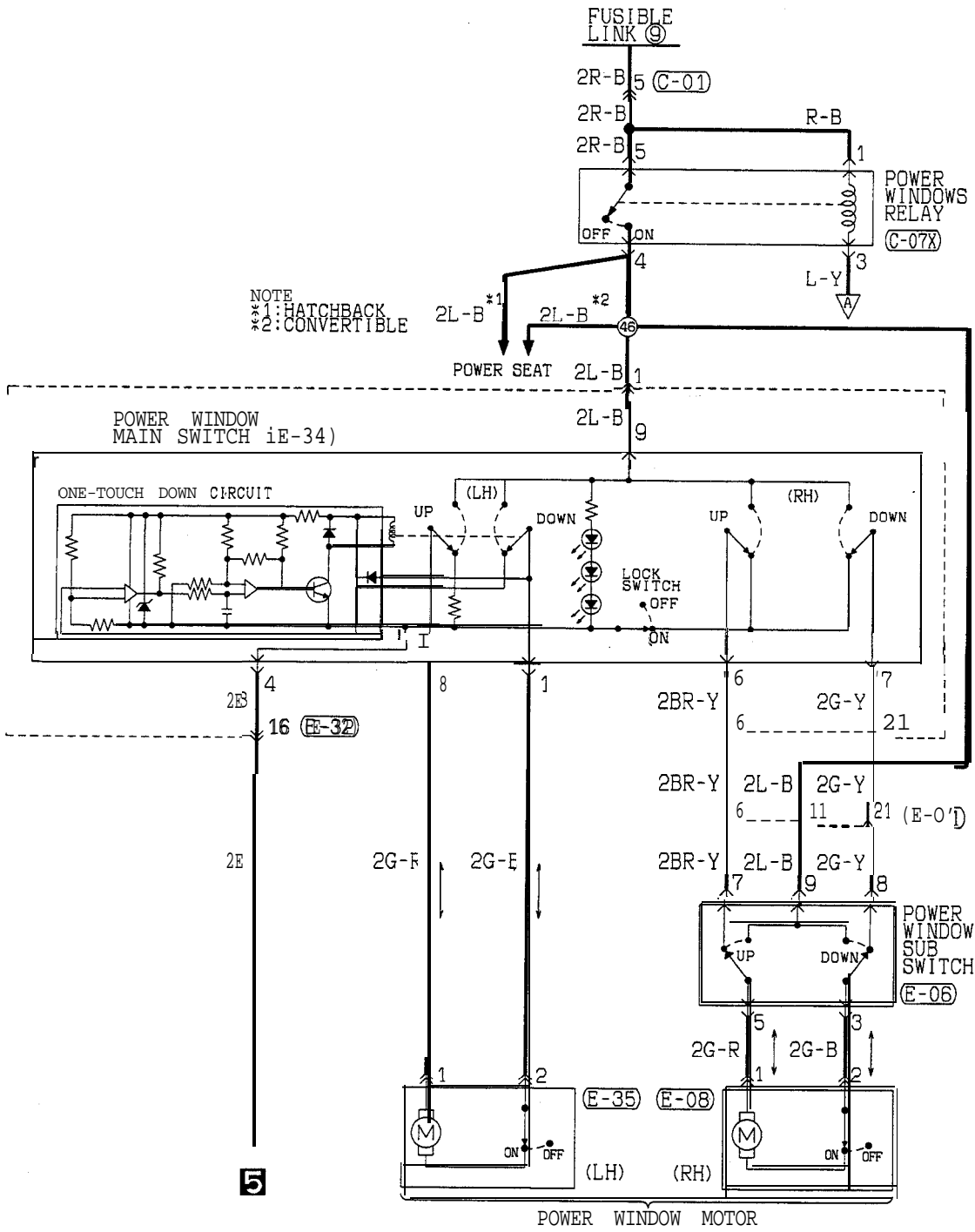

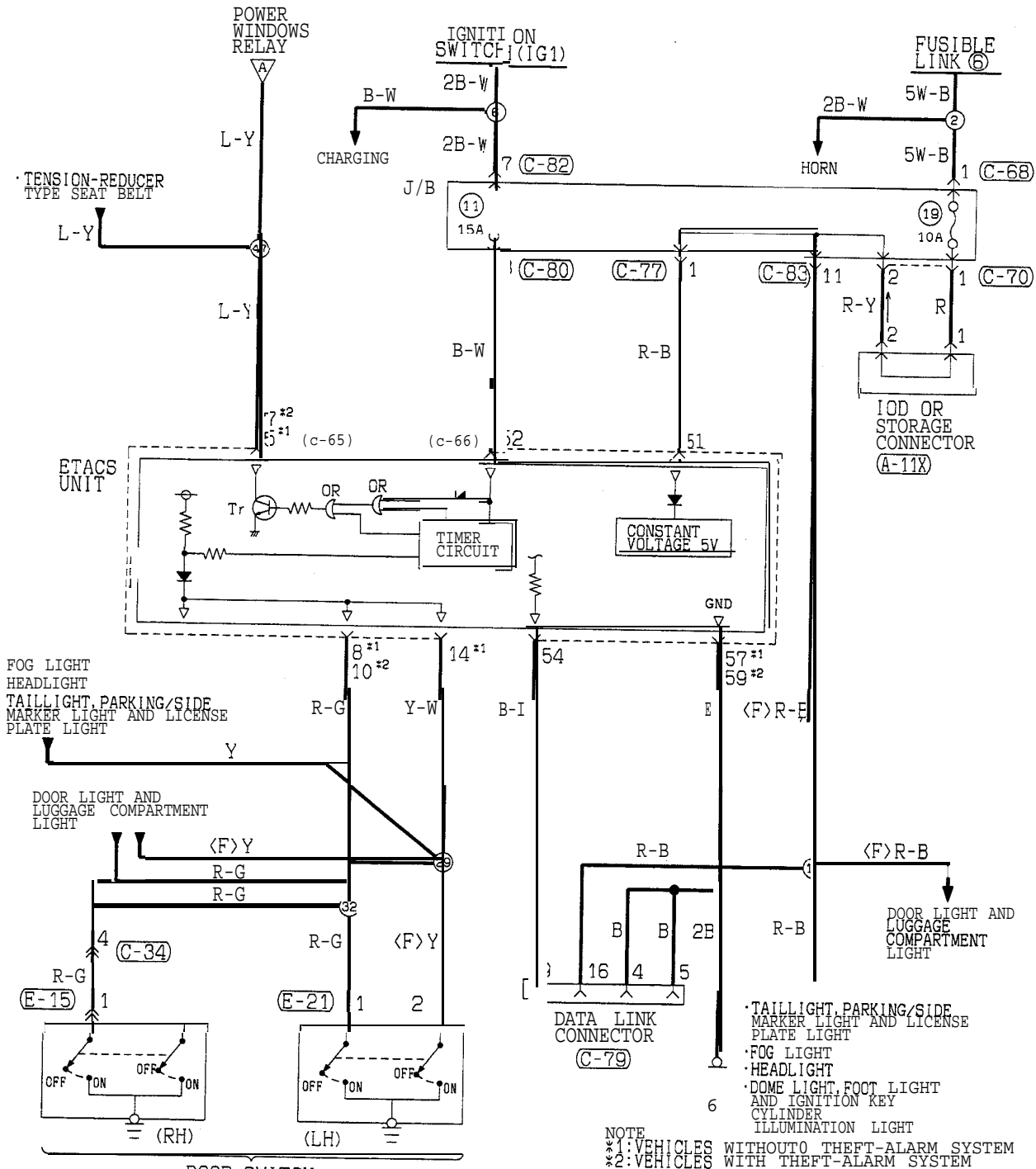

NOTE  
 \*1: VEHICLES WITHOUTO THEFT-ALARM SYSTEM  
 \*2: VEHICLES WITH THEFT-ALARM SYSTEM

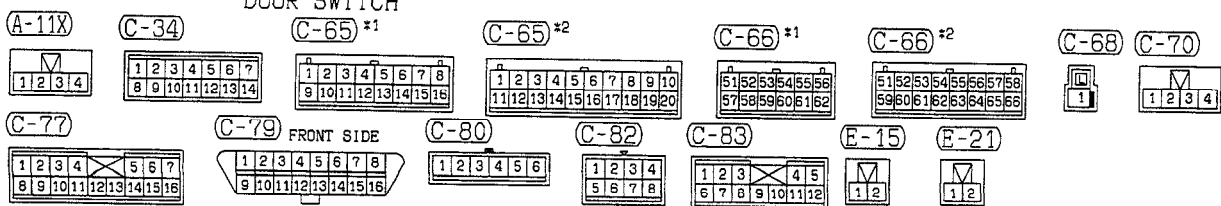

HR11M06AB

TSB Revision

COMPONENT LOCATION

Name	Symbol	Name	Symbol
Data link connector (up to 1993 models)	A	ETACS unit	C
Data link connector (from 1994 models)	D	Power window relay	B

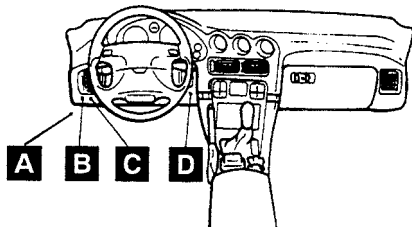

O19F0134

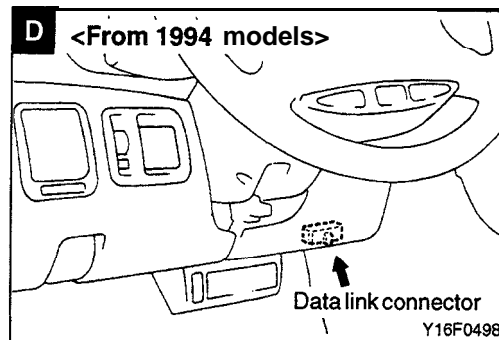
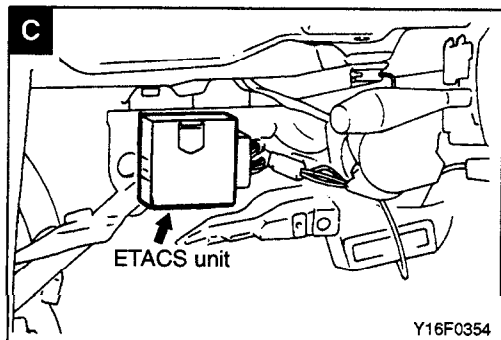
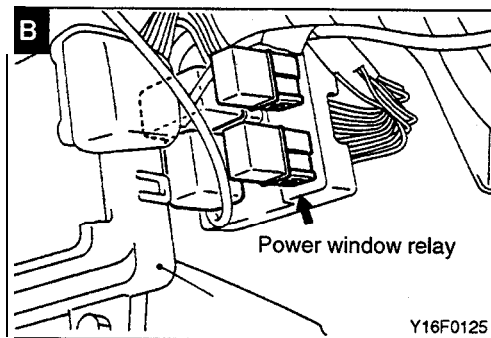
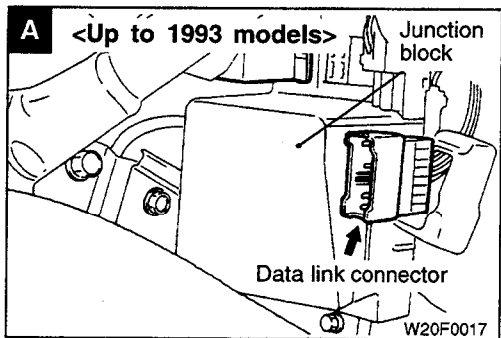

**OPERATION**

- Turn on the ignition switch, and the transistor Tr will be turned on by the timer circuit. This will turn on the power window relay allowing the power window to be opened and closed.
- Turn the ignition switch from on to off, and the timer circuit will be activated to keep transistor Tr on for 30 seconds allowing the power window to be opened and closed.  
Moreover, if the front door is opened, the timer circuit will stop to turn off the transistor Tr. This will prevent the window from being opened and closed.

**TROUBLESHOOTING HINTS**

Phenomenon		Inspection method
All door windows cannot be opened or closed.		<ul style="list-style-type: none"> <li>• Check fusible link No. 9.</li> <li>• Check the power-window relay.</li> <li>• Check the power-window main switch.</li> </ul>
One of the door windows cannot be opened or closed.	Neither of the power-window switches (main or sub) operates	<ul style="list-style-type: none"> <li>• Check the power-window main switch.</li> <li>• Check the power-window motor for the power window that does not operate.</li> </ul>
	Either the power-window main switch or sub switch does not operate.	<ul style="list-style-type: none"> <li>• Check the power-window switch for the power window that does not operate.</li> </ul>
The one-touch down switch function only does not operate.		<ul style="list-style-type: none"> <li>• Replace the power-window main switch.</li> </ul>
The power windows do not operate when the ignition switch is at the "ON" position.		<ul style="list-style-type: none"> <li>• Check the ignition switch input signal. (Refer to GROUP 42–Troubleshooting.)</li> <li>• Check the ignition switch. (Refer to GROUP 54–Ignition Switch.)</li> <li>• Check the power window relay. (Refer to GROUP 42–Power Window)</li> </ul>
The power windows can be opened and closed immediately after ignition switch is switched "OFF", but the power window operation does not stop if a front door is opened within 30 seconds.		<ul style="list-style-type: none"> <li>• Check the front door switch input signal. (Refer to GROUP 42–Troubleshooting.)</li> <li>• Check the front door switch. (Refer to GROUP 42–Door Assembly.)</li> </ul>
The opening and closing operations of the power windows are possible after the timer operation time has elapsed when the ignition switch is set to the "OFF" position.		<ul style="list-style-type: none"> <li>• Check the power window relay. (Refer to GROUP 42–Power Window.)</li> </ul>

# CENTRAL DOOR LOCKING CIRCUIT (UP TO 1993 MODELS)

(Vehicles without keyless entry system)

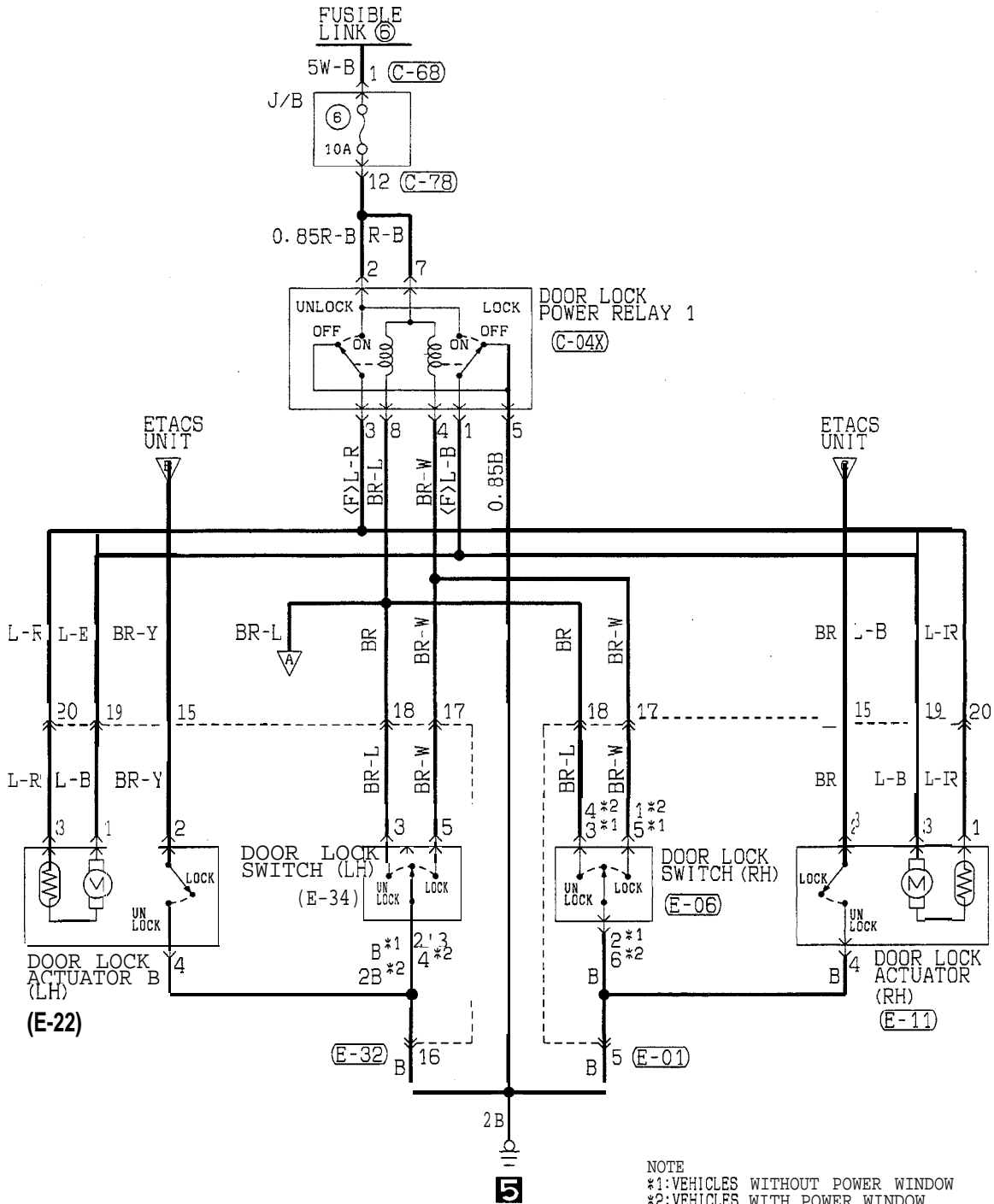

NOTE  
 \*1: VEHICLES WITHOUT POWER WINDOW  
 \*2: VEHICLES WITH POWER WINDOW

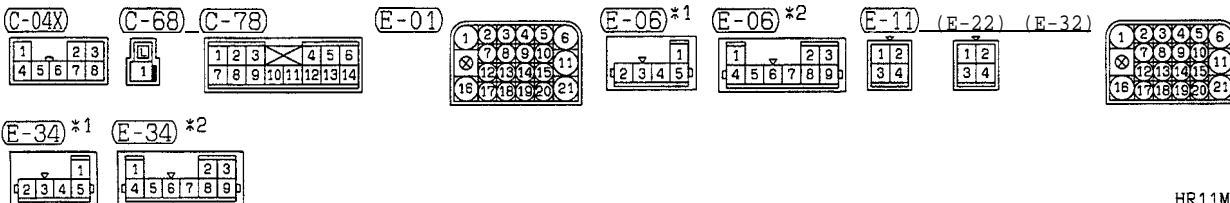

HR11M03AA

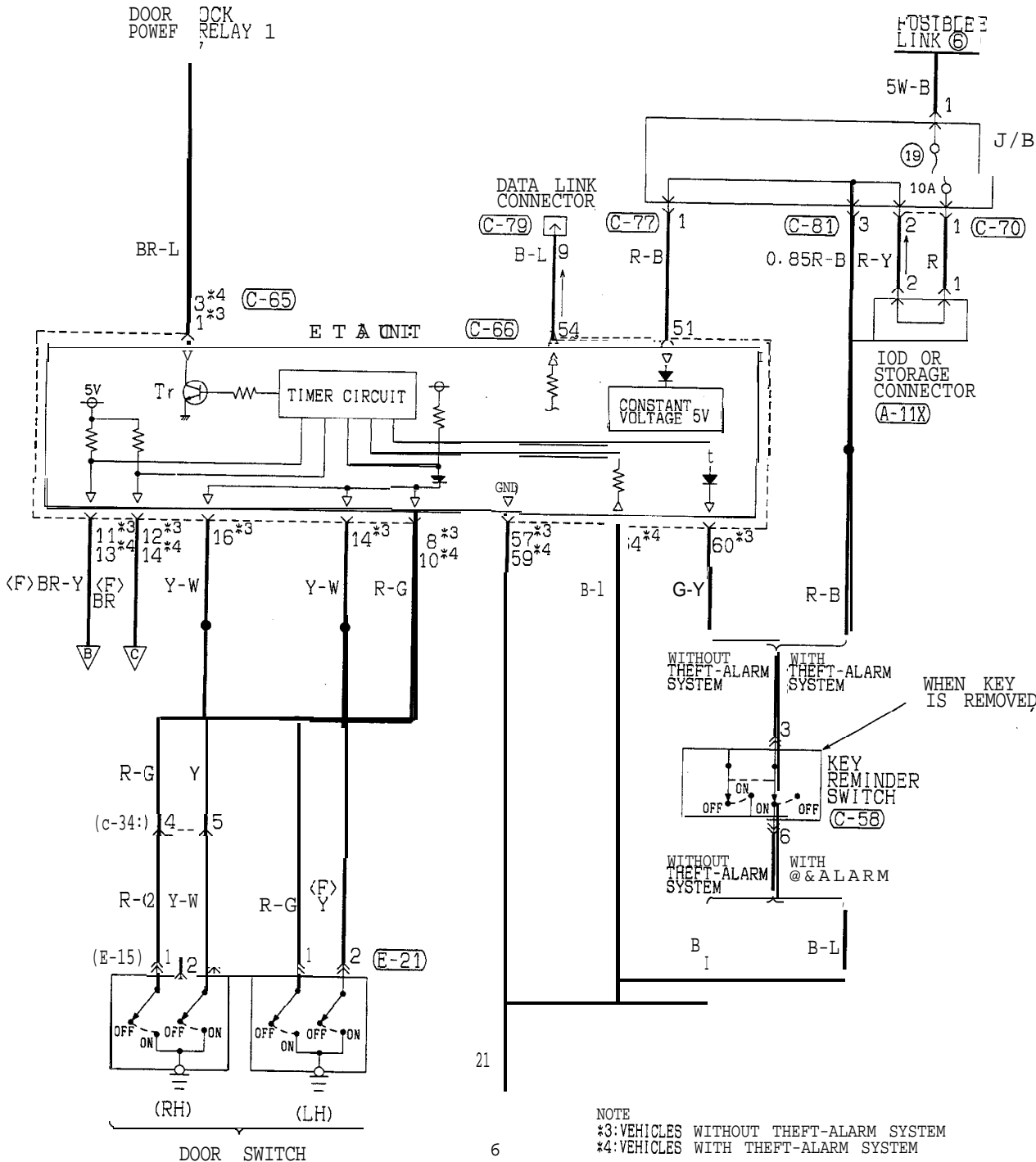

NOTE  
 \*3: VEHICLES WITHOUT THEFT-ALARM SYSTEM  
 \*4: VEHICLES WITH THEFT-ALARM SYSTEM

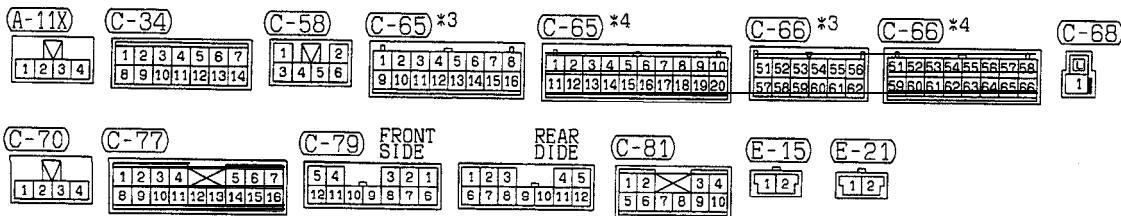

TSB Revision

**CENTRAL DOOR LOCKING CIRCUIT (UP TO 1993 MODELS)**

(Vehicles with keyless entry system)

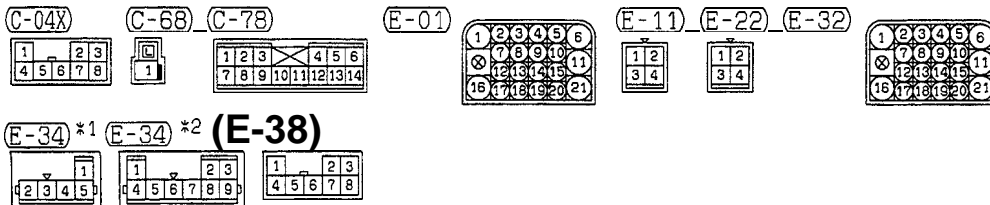
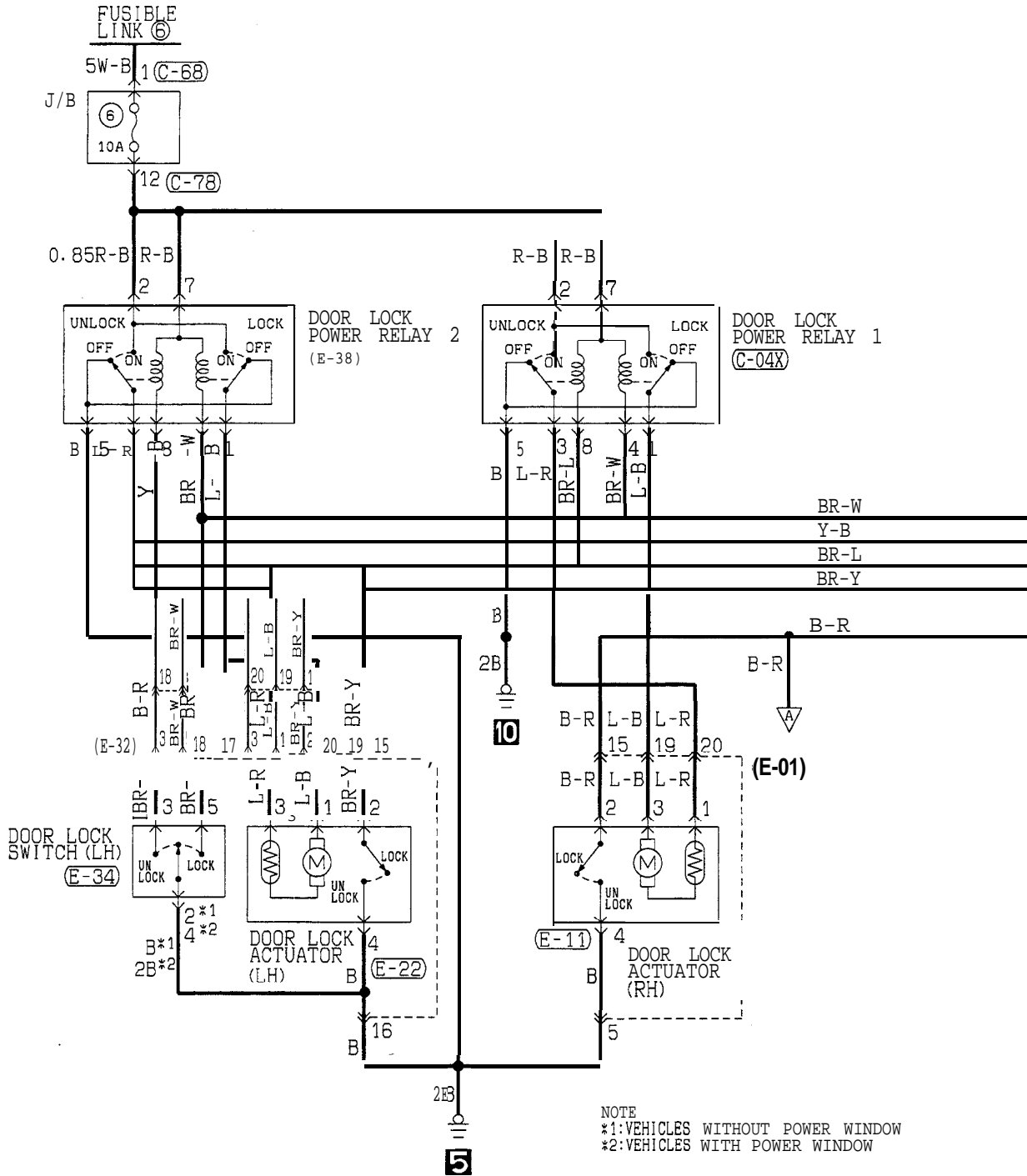

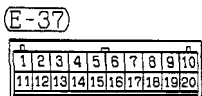
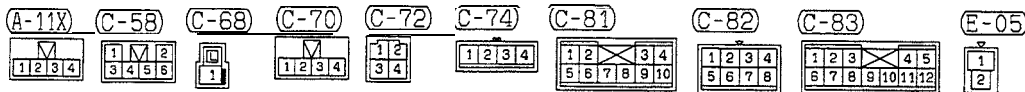
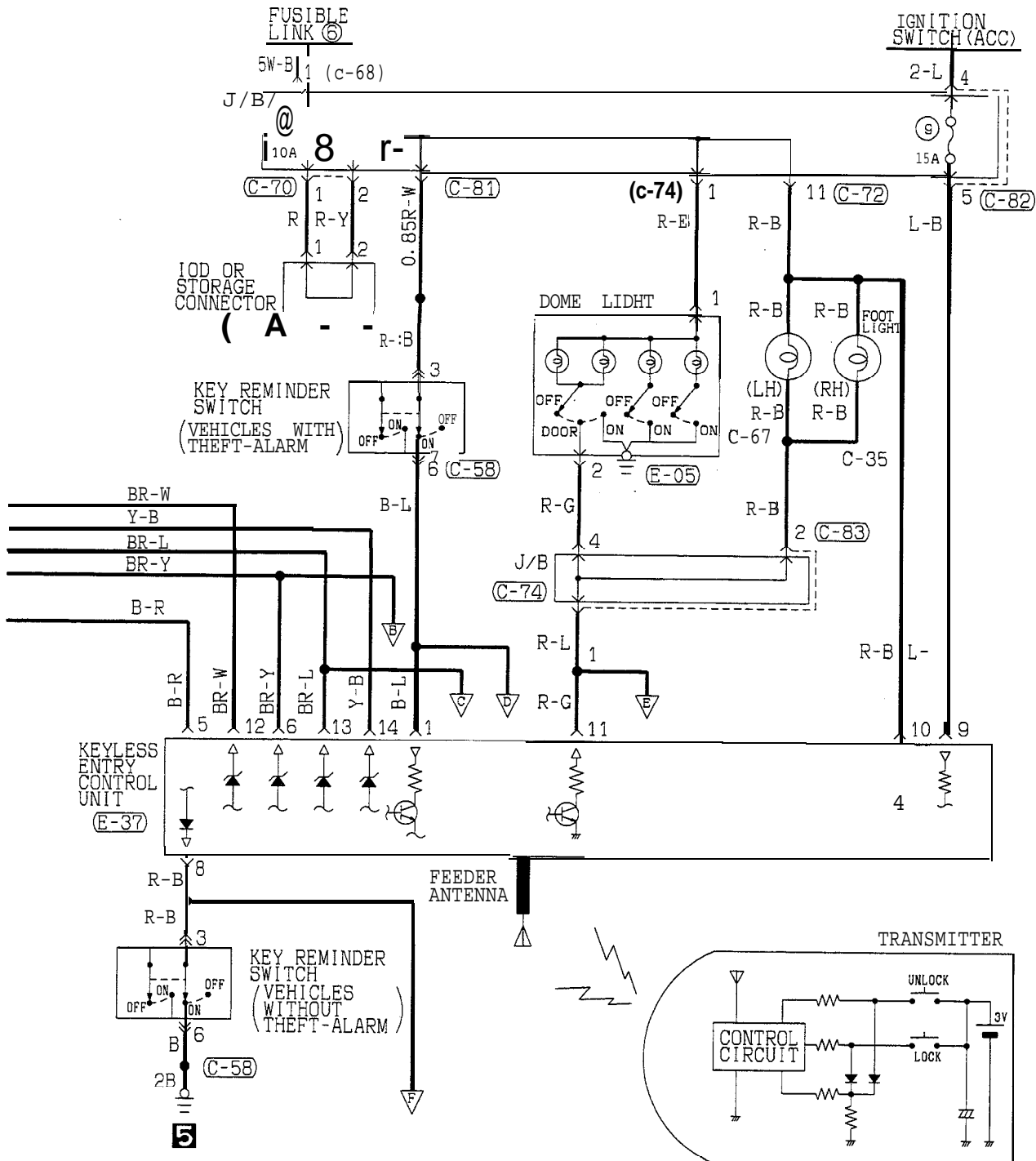

HR11M04AB

TSB Revision



**CENTRAL DOOR LOCKING CIRCUIT (UP TO 1993 models)  
(Vehicles with keyless entry system) (CONTINUED)**

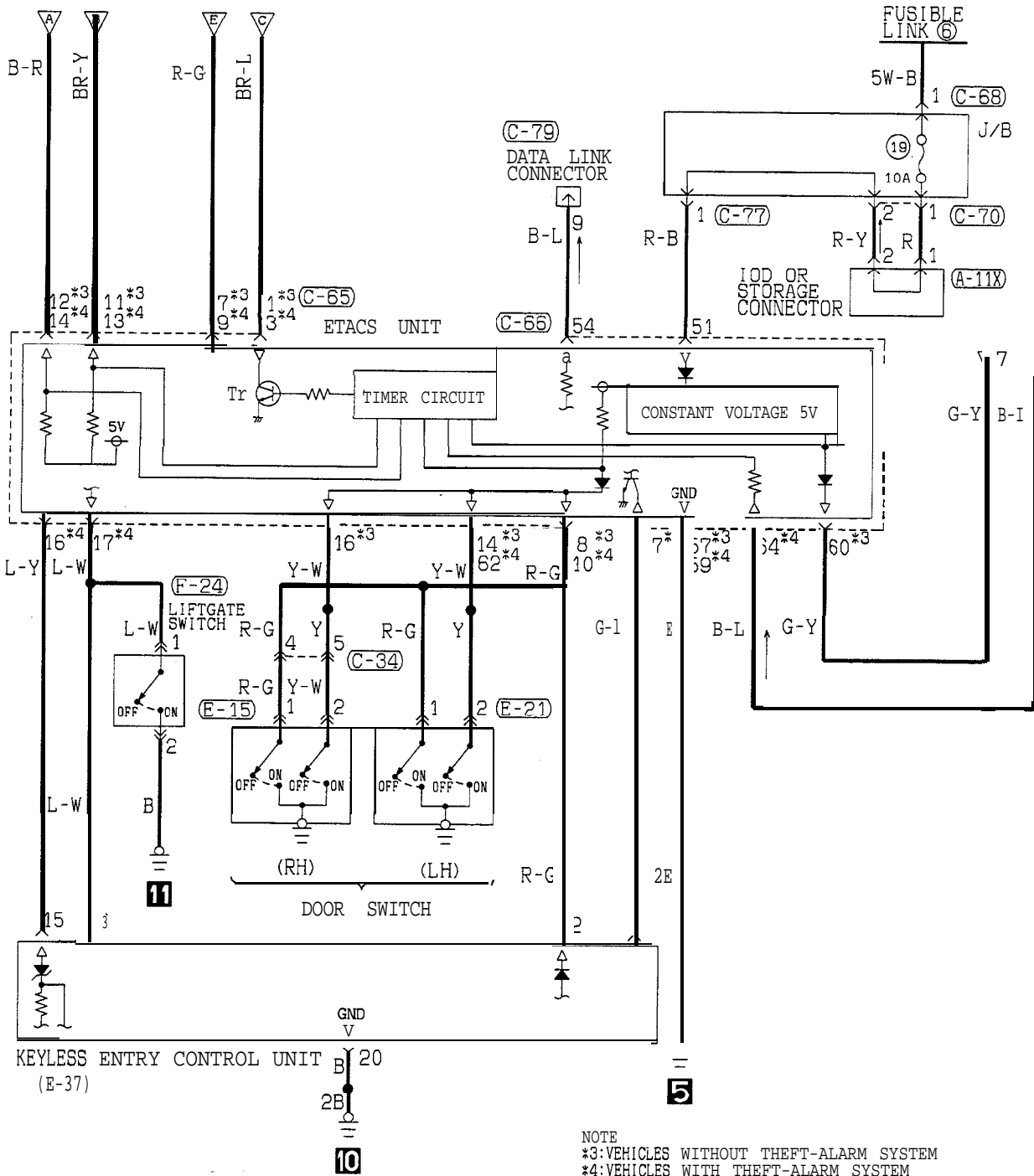

NOTE  
\*3: VEHICLES WITHOUT THEFT-ALARM SYSTEM  
\*4: VEHICLES WITH THEFT-ALARM SYSTEM

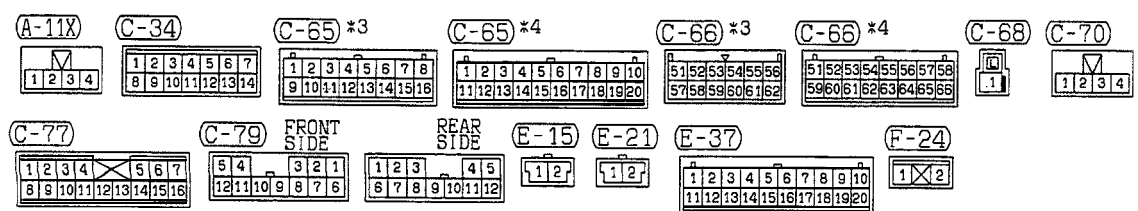

TSB Revision

---

NOTES

# CENTRAL DOOR LOCKING CIRCUIT (1994, 1995 MODELS)

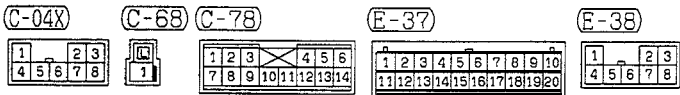
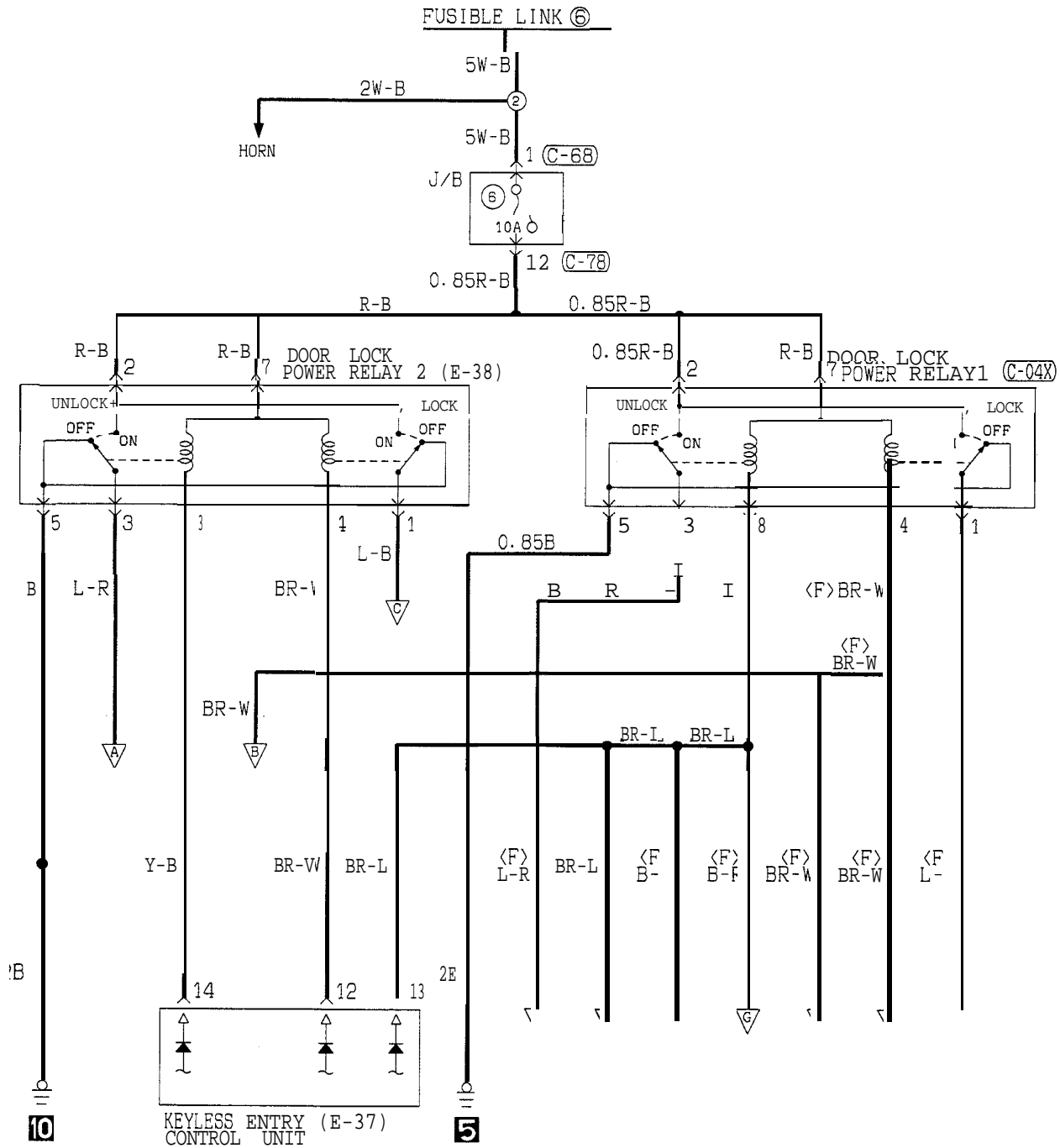

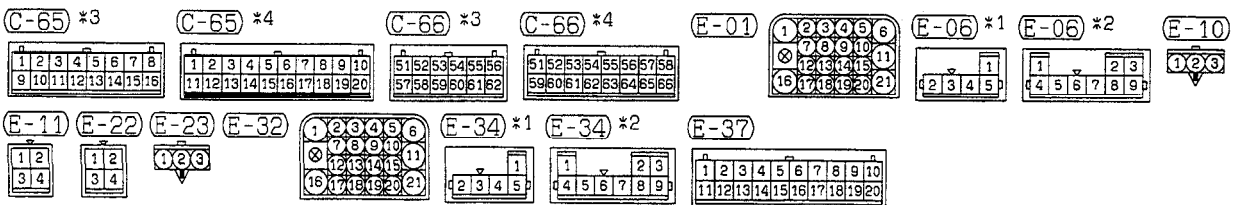
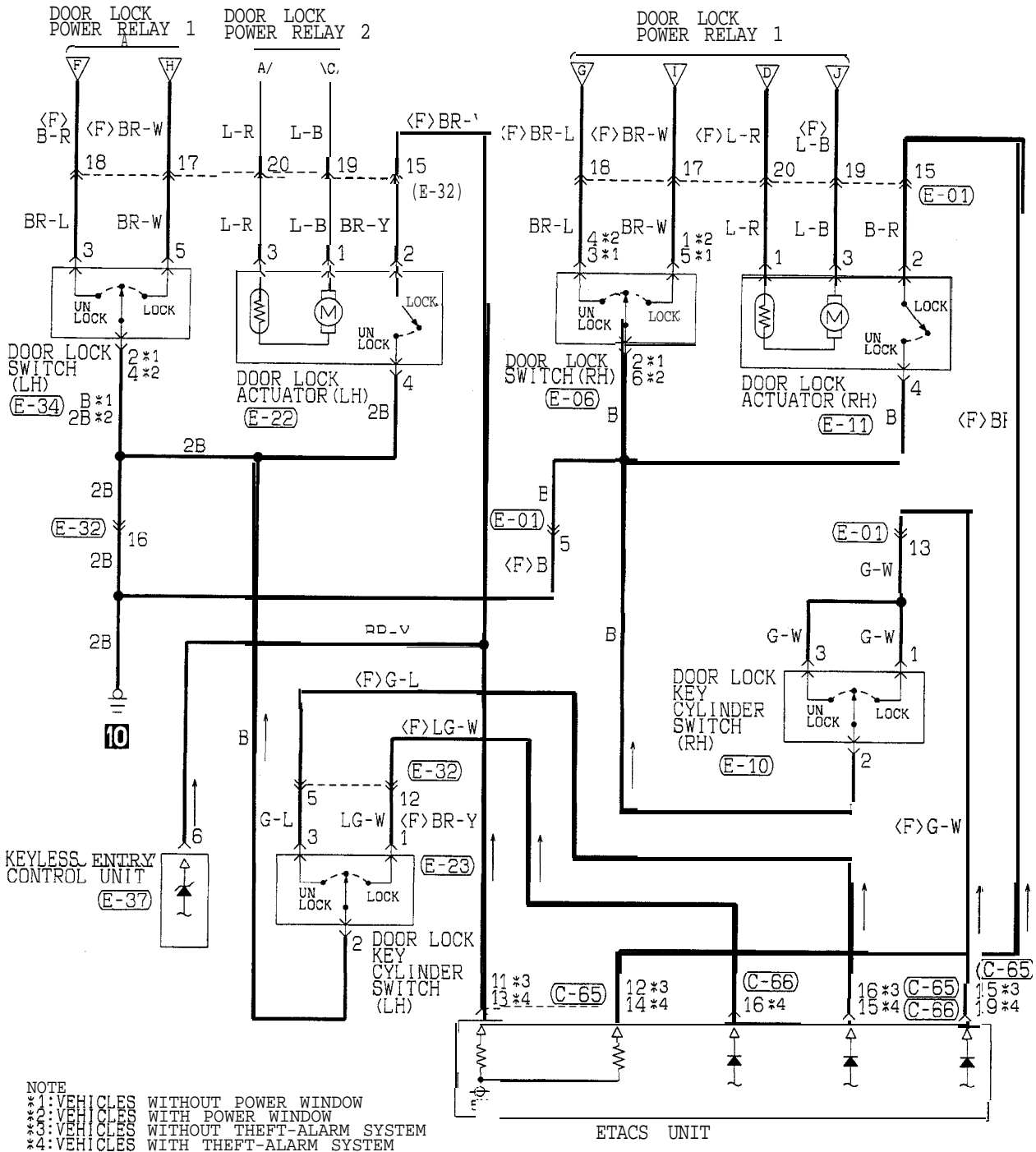

CENTRAL DOOR LOCKING CIRCUIT (1994, 1995 MODELS) (CONTINUED)

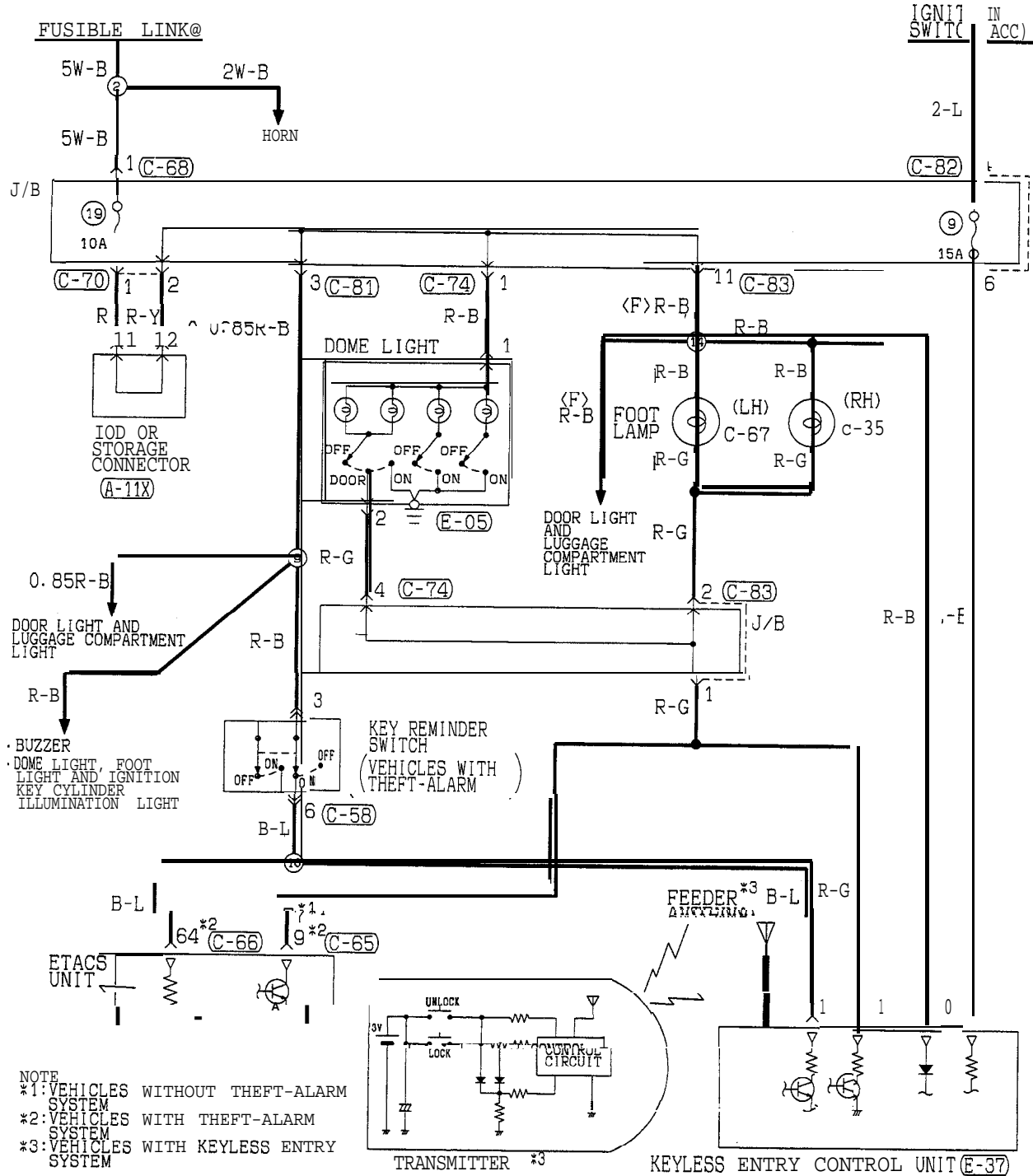

NOTE  
 \*1: VEHICLES WITHOUT THEFT-ALARM SYSTEM  
 \*2: VEHICLES WITH THEFT-ALARM SYSTEM  
 \*3: VEHICLES WITH KEYLESS ENTRY SYSTEM

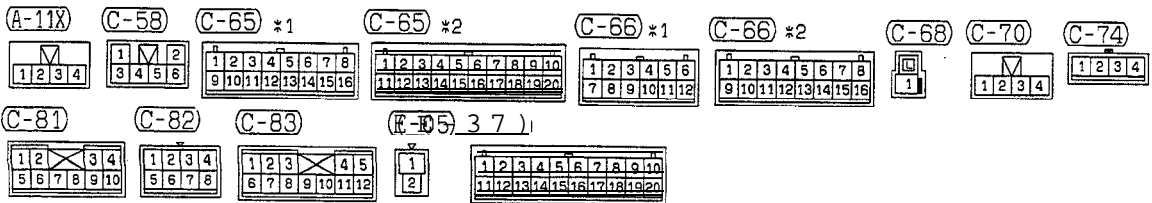

TSB Revision

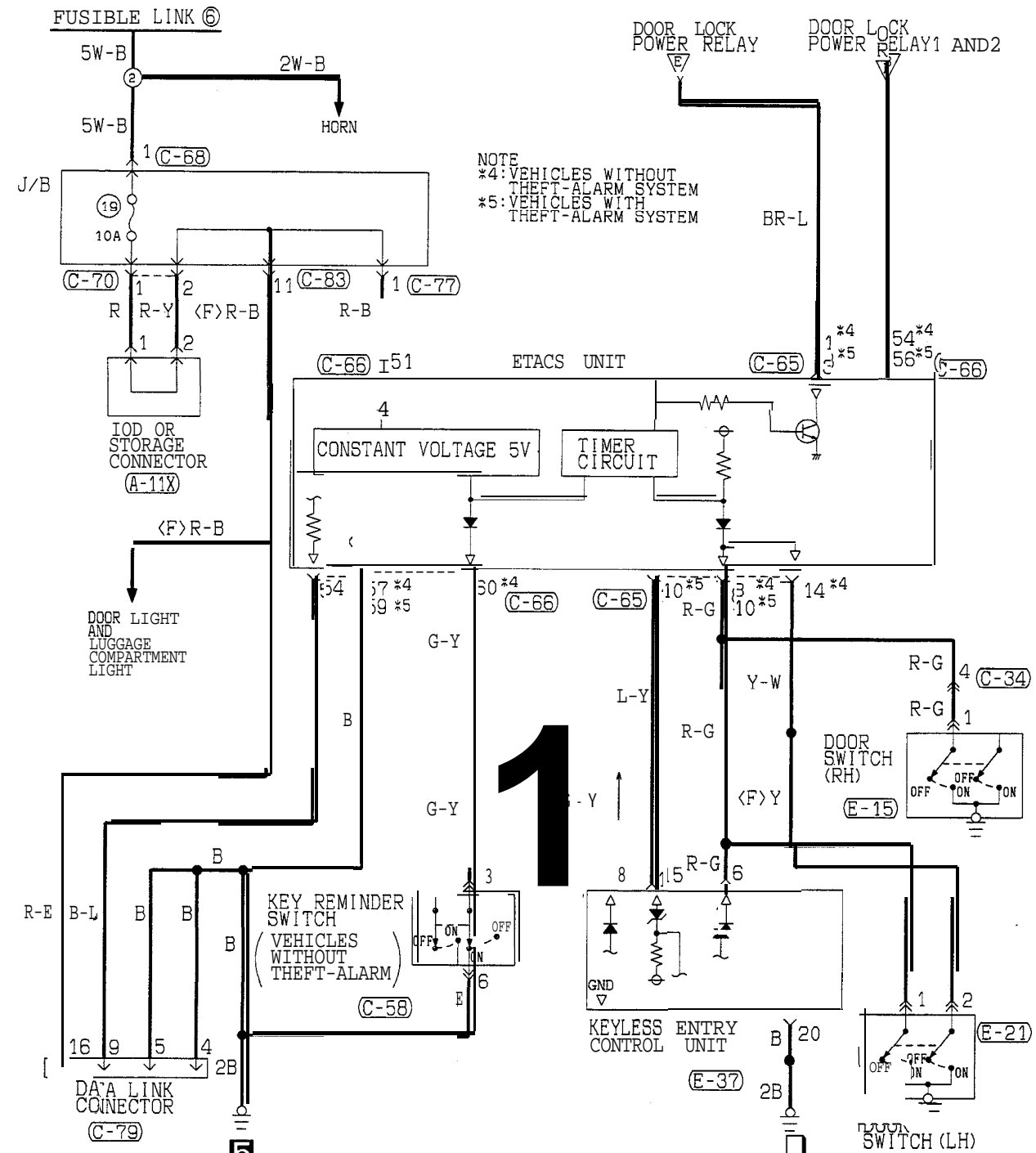

NOTE  
 \*4: VEHICLES WITHOUT THEFT-ALARM SYSTEM  
 \*5: VEHICLES WITH THEFT-ALARM SYSTEM

**1**

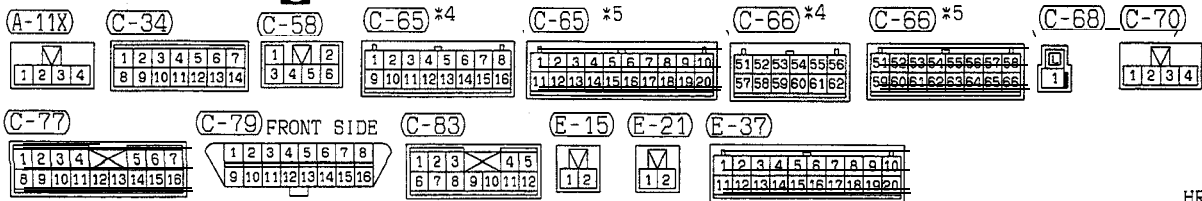

TSB Revision

CENTRAL DOOR LOCKING CIRCUIT (FROM 1996 MODELS)

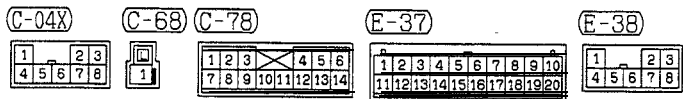
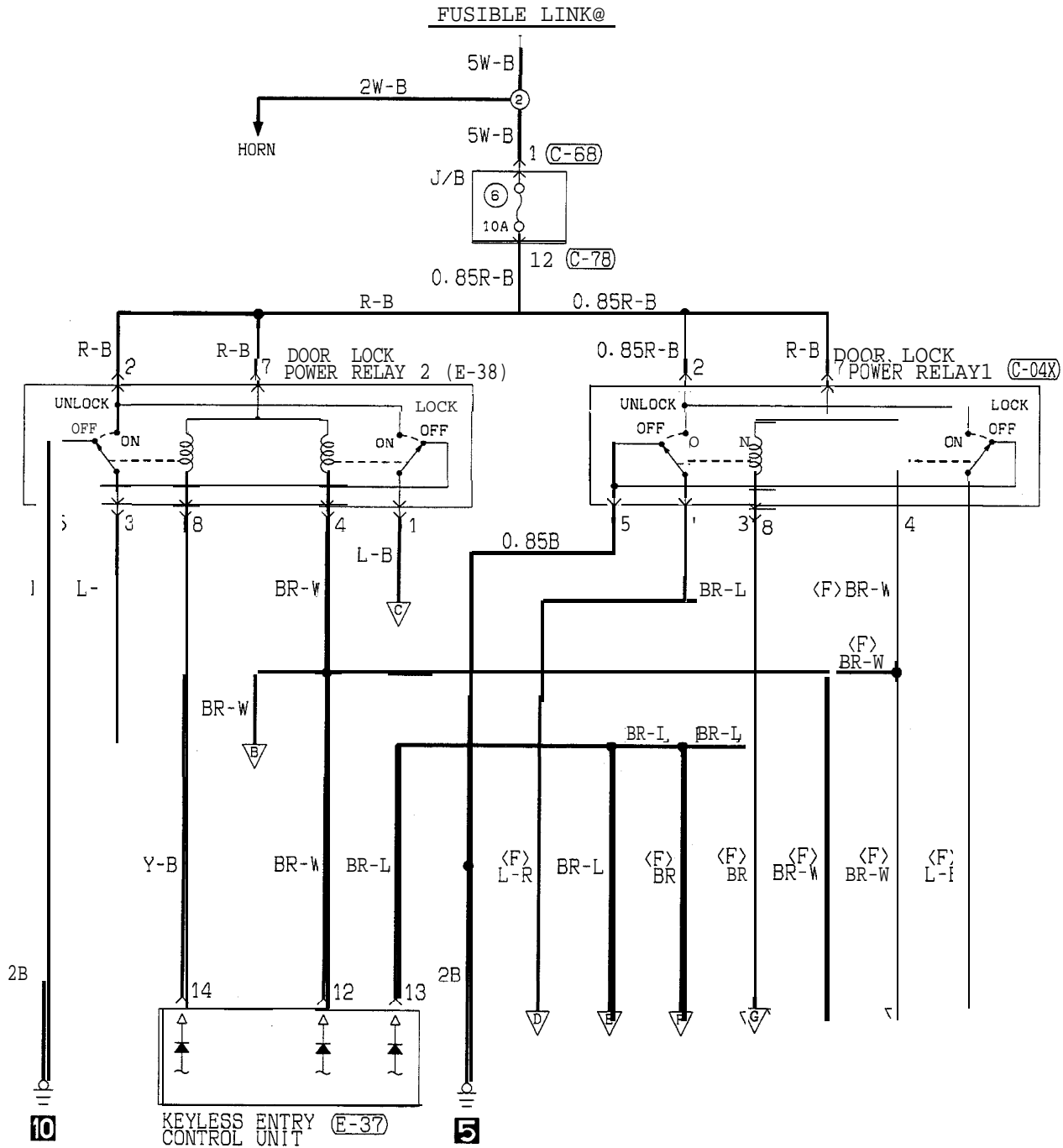

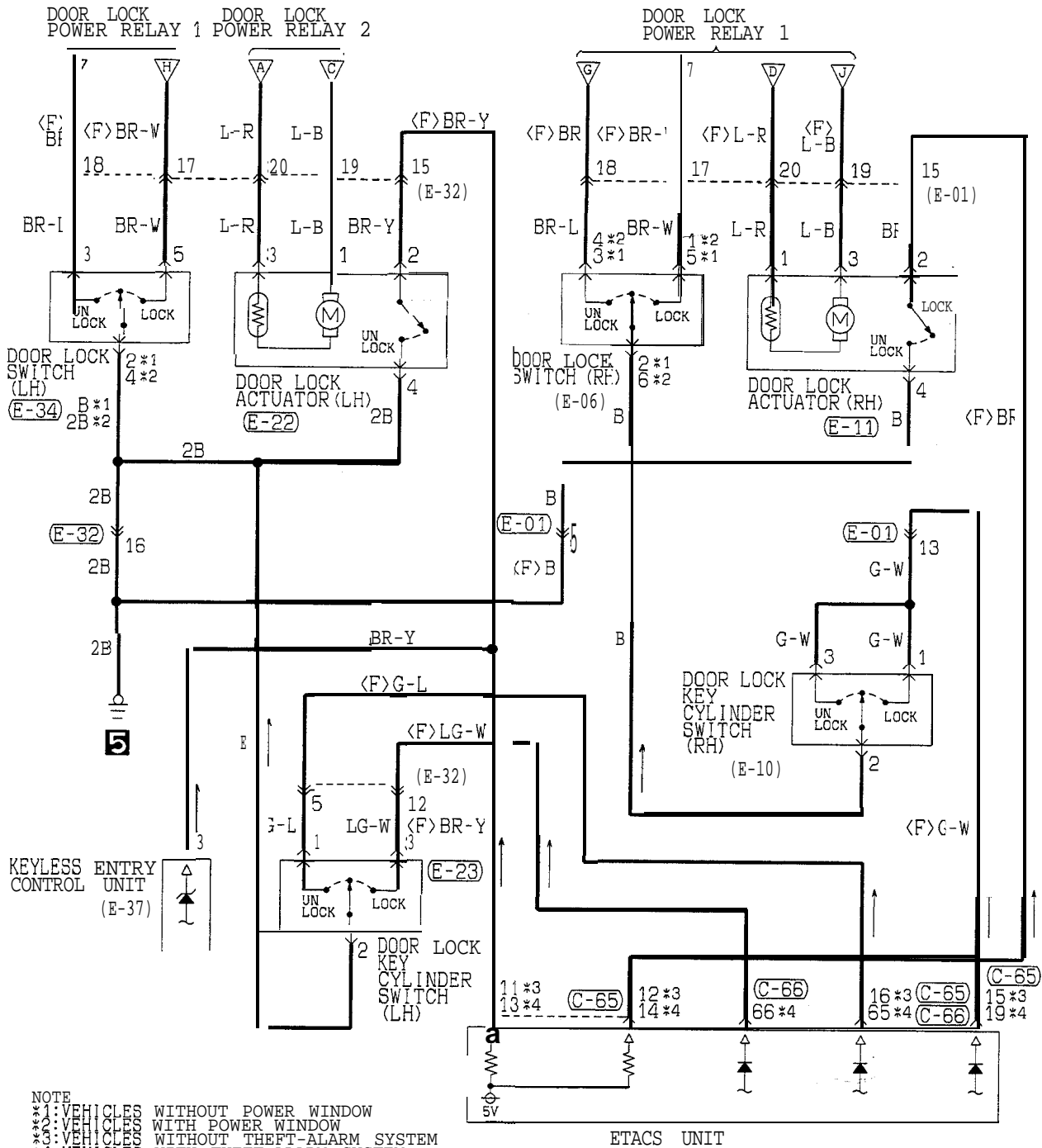

NOTE  
 \*1: VEHICLES WITHOUT POWER WINDOW  
 \*2: VEHICLES WITH POWER WINDOW  
 \*3: VEHICLES WITHOUT THEFT-ALARM SYSTEM  
 \*4: VEHICLES WITH THEFT-ALARM SYSTEM

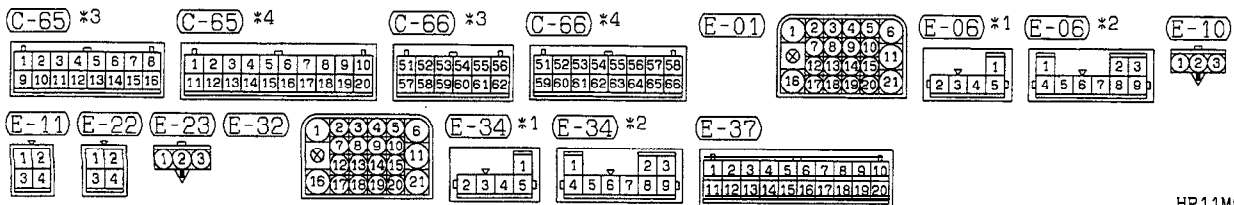

HR11M07AB

TSB Revision



CENTRAL DOOR LOCKING CIRCUIT (FROM 1996 MODELS) (CONTINUED)

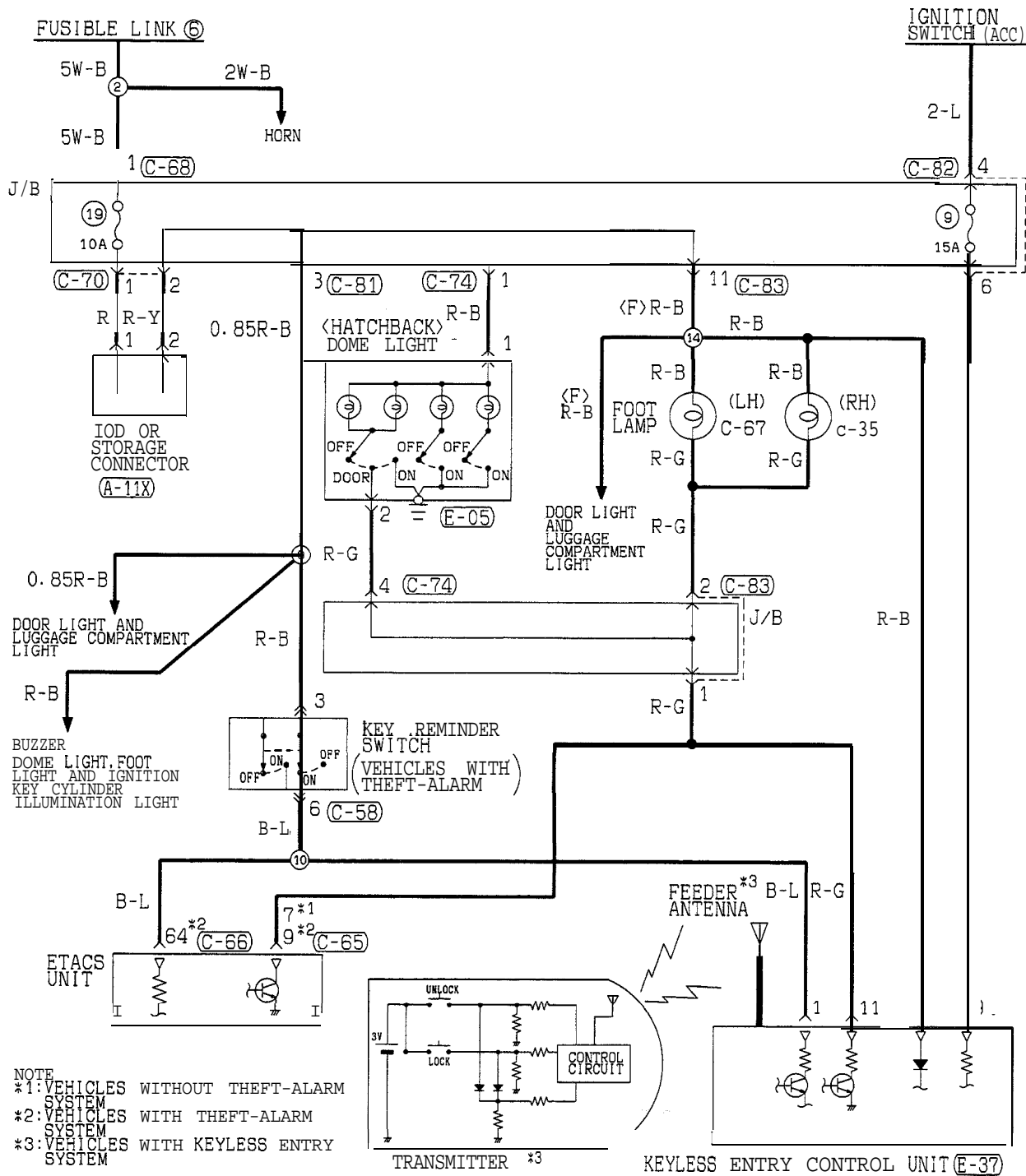

NOTE  
 \*1: VEHICLES WITHOUT THEFT-ALARM SYSTEM  
 \*2: VEHICLES WITH THEFT-ALARM SYSTEM  
 \*3: VEHICLES WITH KEYLESS ENTRY SYSTEM

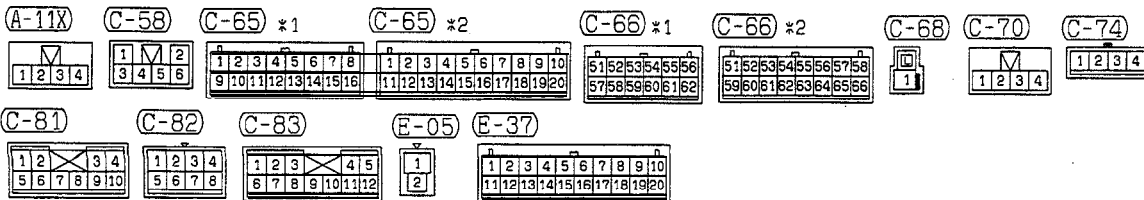

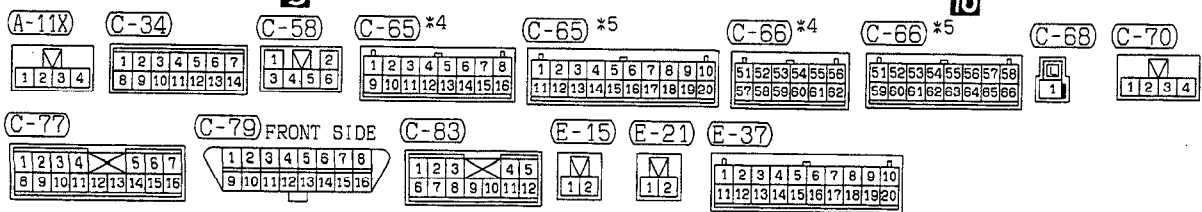
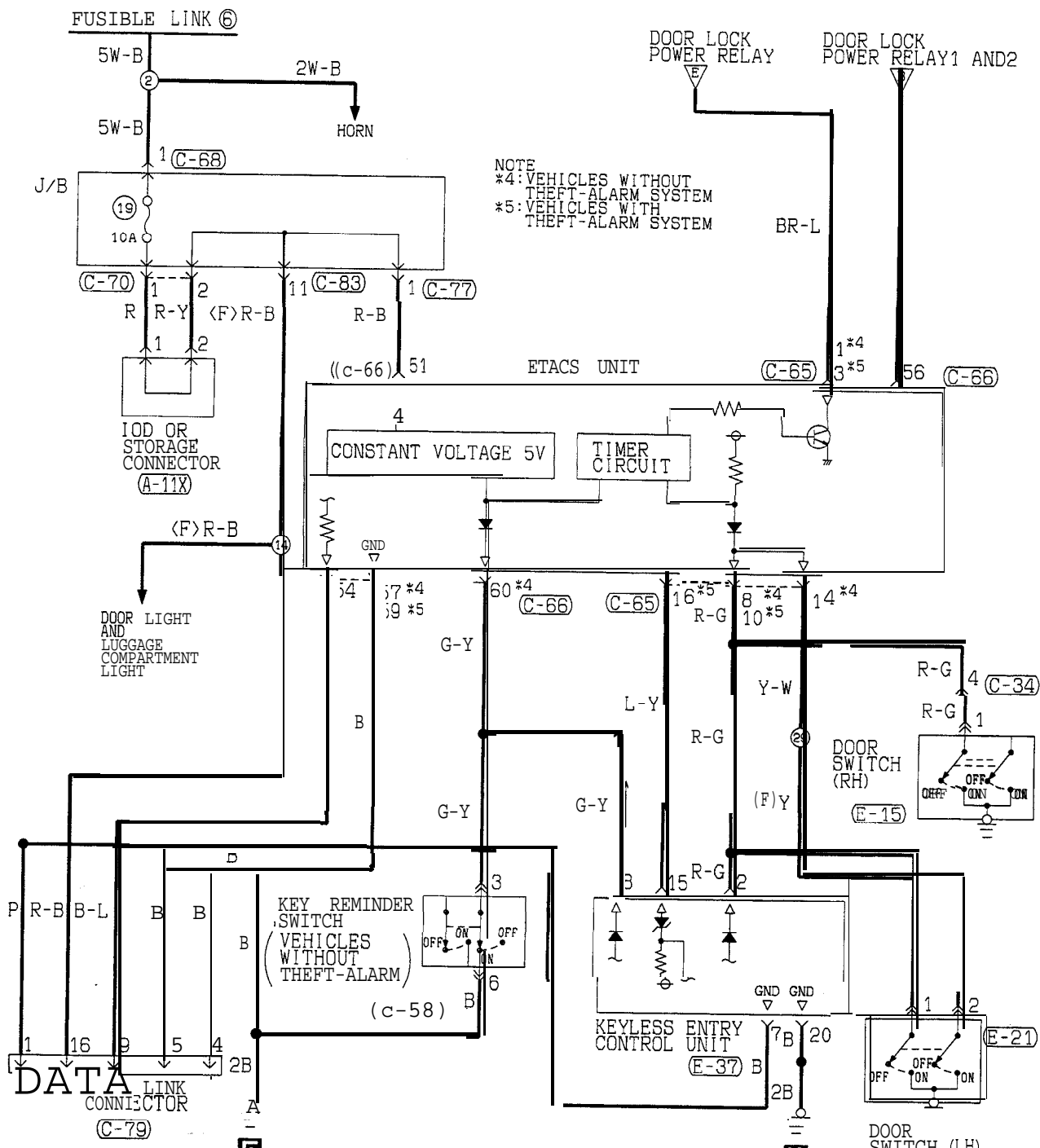

TSB Revision

COMPONENT LOCATION

Name	Symbol	Name	Symbol
Data link connector (from 1994 models)	D	Door lock power relay 2 (Concerning the vehicles up to 1993 models, only for the vehicles equipped with keyless entry system.)	F
Data link connector (up to 1993 models)	A	ETACS unit	C
Door lock actuator	E	Keyless entry control unit	F
Door lock power relay 1	B		

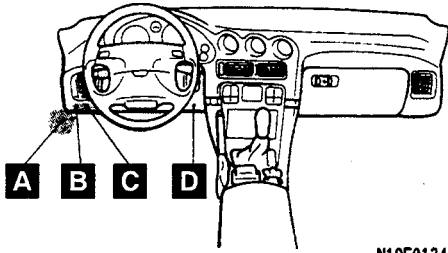

N19F0134

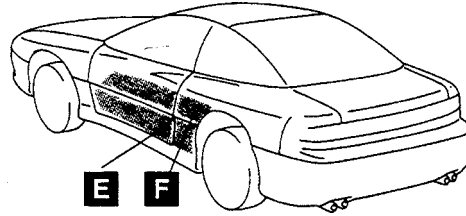

W16F0268  
00002684

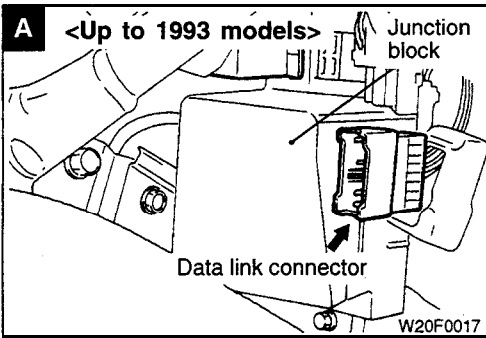

W20F0017

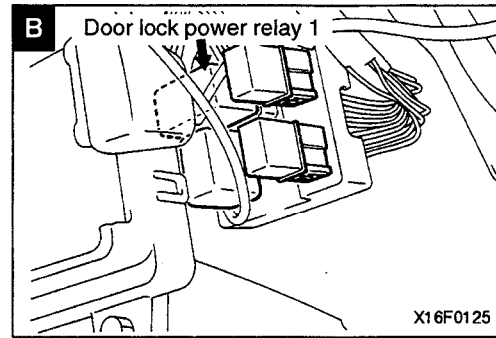

X16F0125

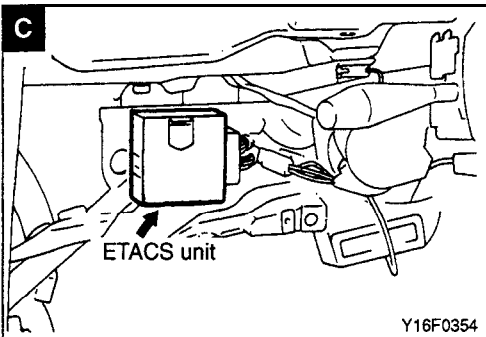

Y16F0354

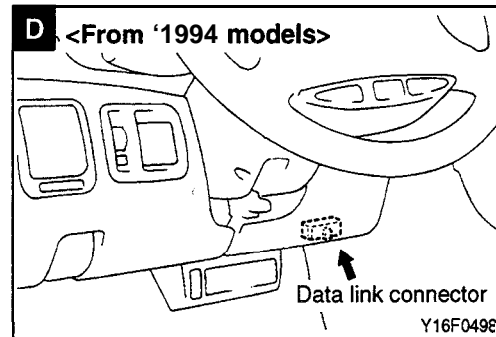

Y16F049E

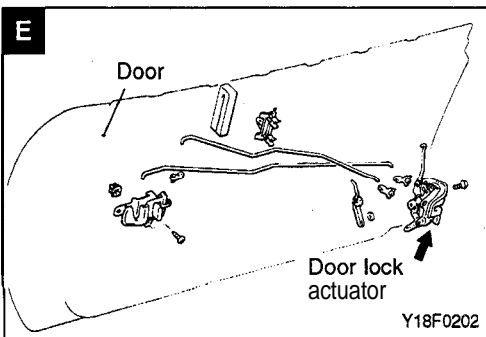

Y18F0202

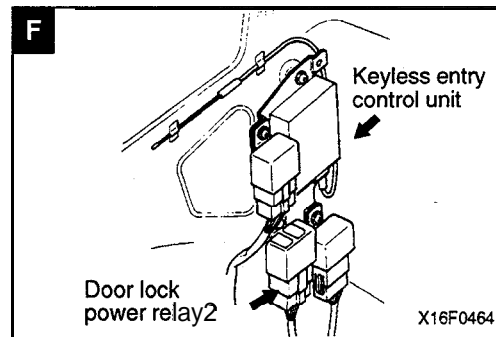

X16F0464

**OPERATION**

**<Vehicles without keyless entry system>**

- When the door lock switch is set to the LOCK side (or UNLOCK side), the LOCK side (or UNLOCK side) of the door lock relay is turned ON and the door actuators of all doors operate.
- If the driver seat side door (or assistant seat side door) is opened and the driver seat side inside lock knob (or assistant seat side inside

lock knob) is locked with the key inserted in the ignition switch, the ETACS unit grounds the unlock side circuit of the door lock relay to unlock all doors. This way, failure to remove the key is prevented.

**<Vehicles with keyless entry system>**

- With the driver's and front passenger's doors unlocked, press the LOCK switch of the transmitter, and the door lock signal output (0 V) will be sent from the keyless entry control unit terminal No. 12 closing the door lock power relays 1 and 2 to lock the driver's and front passenger's doors.
- While the R.H. and L.H. doors are in the locked state, press the UNLOCK switch of the transmitter once, and the DOOR UNLOCK switch signal (0 V) will be sent from the keyless entry control unit terminal No. 14 closing the door lock power relay 2 to unlock the driver's door.
- Under the above-mentioned conditions, further press the UNLOCK switch of the transmitter, and the DOOR UNLOCK signal output (0 V) will be sent from the keyless entry control unit terminal No. 13 closing the door lock power relay 1 to lock the front passenger's door.
- When the keyless entry system is operated to turn the driver's door lock switch from the UNLOCK position to the LOCK position, the

dome light/foot light blinking signal output (system voltage) will be sent twice from the keyless entry control unit terminal No. 11 when the door lock switch is turned from the LOCK position to the UNLOCK position, the lighting signal output (0 V) will be provided for approx. 3 seconds.

**NOTE**

The dome light winks or comes on when the dome light switch is in the DOOR interlock position. However, the dome light does not wink while it is ON for 6 seconds after closing the door by ETACS function.

Besides the above-mentioned operations, the keyless entry control unit has the following functions.

- If any door is not opened or closed within 30 seconds from unlocking the door by means of the keyless entry system, the door is automatically locked. In addition, if the cryptographic code other than the code stored in the receiver memory is received 30 times in one minute continuously, operation of the unit is suspended for 10 minutes.
- Operation is also suspended if the ignition key remains inserted (key reminder switch: OFF) and either door is left open (door switch: ON).

**TROUBLESHOOTING HINTS**

**<Vehicles without keyless entry system>**

Phenomenon	Inspection method
One of the door lock actuators fails to operate.	<ul style="list-style-type: none"> <li>• Check the door actuator which fails to operate.</li> </ul>
No unlock operation can be made by pressing door lock knob after fulfilment of following conditions. <ul style="list-style-type: none"> <li>• Insertion of key in ignition switch (key reminder switch OFF)</li> <li>• Opening of door (door switch ON)</li> </ul>	<ul style="list-style-type: none"> <li>• Check the key reminder switch input signal.</li> <li>• Check the key reminder switch. (Refer to GROUP 54–Ignition Switch.)</li> <li>• Check the front door switch input signal.</li> <li>• Check the front door switch. (Refer to GROUP 42–Door Assembly)</li> </ul>

## &lt;Vehicles with keyless entry system&gt;

- The indicator does not blink after pressing the transmission switch of the transmitter.
  - 1) Check or replace the battery. (Refer to GROUP 42–Keyless Entry System.)
  - 2) Replace the transmitter.
- Transmitted wave is being sent from the transmitter (indicator is blinking), but the system does not operate.
  - 1) Check the cryptographic code registering method. (Refer to GROUP 42–Keyless Entry System.)
  - 2) Check the keyless entry control unit terminal voltage. (Refer to GROUP 42–Troubleshooting.)
  - 3) Check the coaxial cable of antenna and the ground wire for connection.
- Only R.H. or L.H. door can be locked or unlocked.
  - 1) Check the door lock power relay 1 (for front passenger's door) or door lock power relay 2 (for driver's door). (Refer to GROUP 42–Central Door Locking System.)
  - 2) Check the keyless entry control unit terminal voltage. (Refer to GROUP 42–Troubleshooting.)
- R.H. and L.H. doors can be locked and unlocked by the transmitter but the dome light and foot light do not blink or come on. (Interlocked lighting of the dome light and foot light by means of the dome light switch or door opening and closing is normal).
  - 1) Check the keyless entry control unit terminal voltage (Refer to GROUP 42–Troubleshooting.)
  - 2) Check the harness.

## NOTE

- Perform this check when replacement of the transmitter and/or keyless entry control unit or faulty storage of cryptographic code has been made.

HEATER CIRCUIT (UP TO 1995 MODELS)

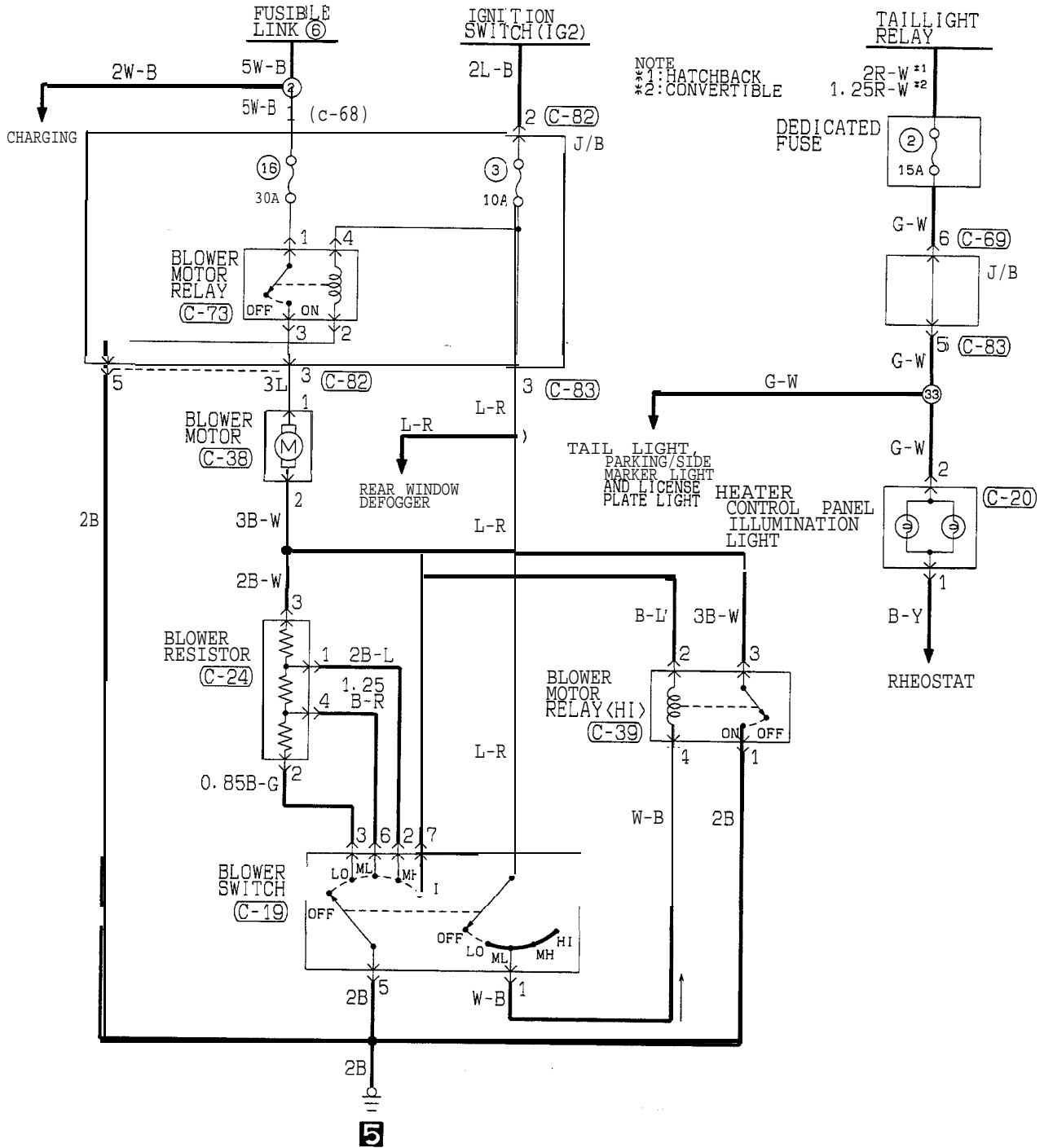

NOTE  
 \*1: HATCHBACK  
 \*2: CONVERTIBLE

1. 2R-W \*1  
 2. 25R-W \*2

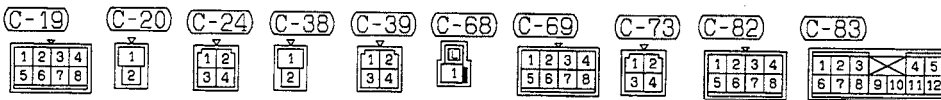

HEATER CIRCUIT (FROM 1996 MODELS)

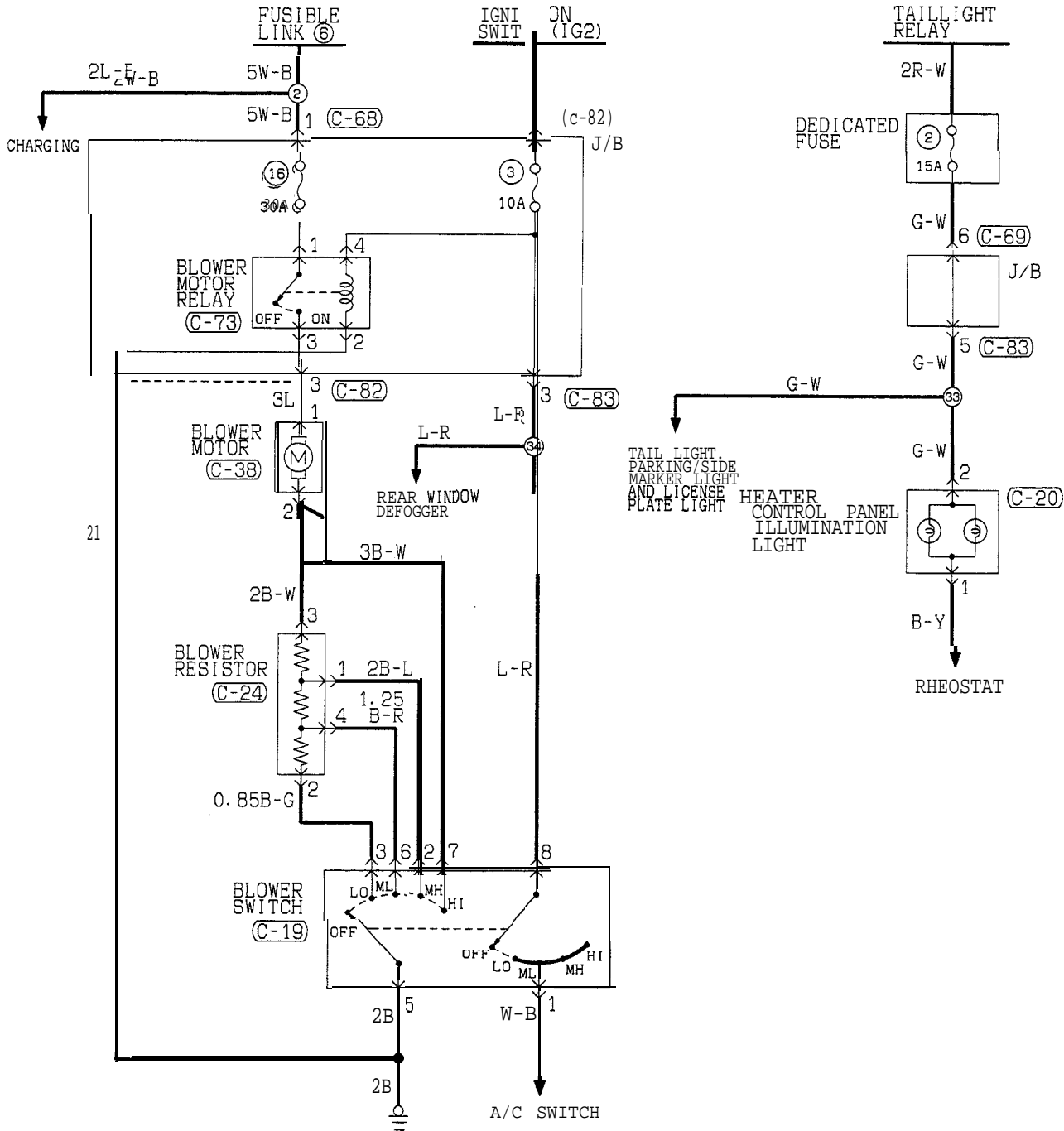

- (c-19) (C-20) (C-24) (C-38) (C-68) (C-69) (C-73) (C-82) (C-83)
- |                    |        |            |        |        |                    |            |                    |                                  |
|--------------------|--------|------------|--------|--------|--------------------|------------|--------------------|----------------------------------|
| 1 2 3 4<br>5 6 7 8 | 1<br>2 | 1 2<br>3 4 | 1<br>2 | 1<br>2 | 1 2 3 4<br>5 6 7 8 | 1 2<br>3 4 | 1 2 3 4<br>5 6 7 8 | 1 2 3 4<br>5 6 7 8<br>9 10 11 12 |
|--------------------|--------|------------|--------|--------|--------------------|------------|--------------------|----------------------------------|

COMPONENT LOCATION

Name	Symbol	Name	Symbol
Blower motor relay	A	Blower resistor	B
Blower motor relay (HI) (Up to 1995 models)	C		

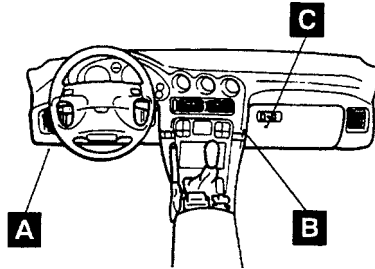

M19F0134

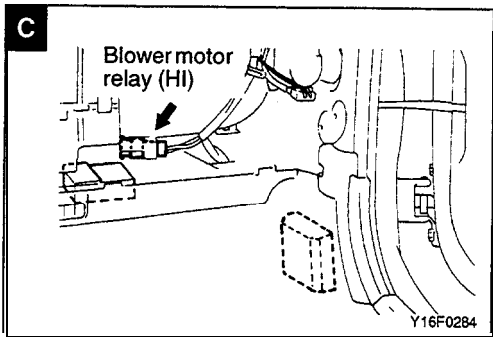
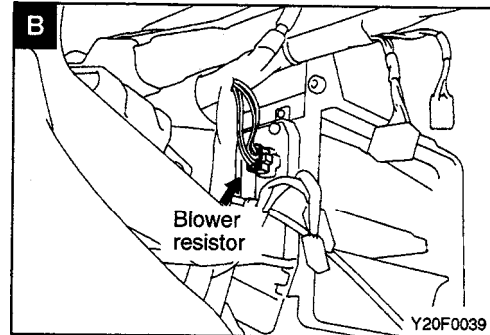
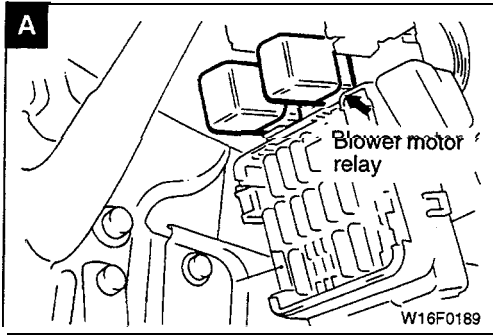



MANUAL AIR CONDITIONING CIRCUIT (1992 MODEL)

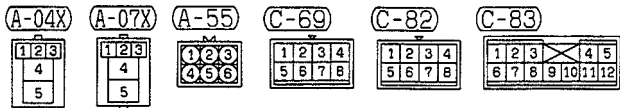
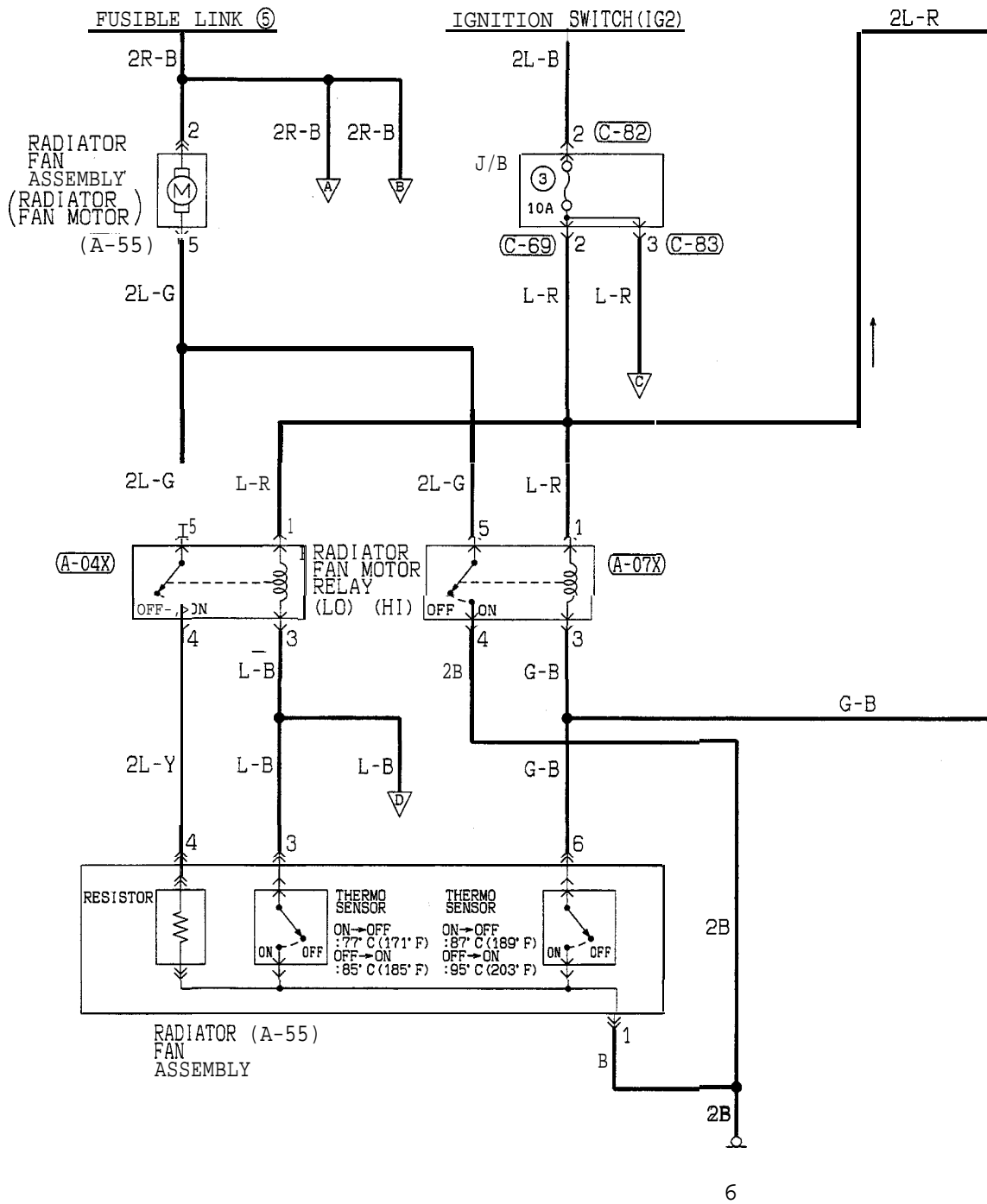

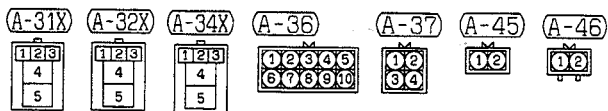
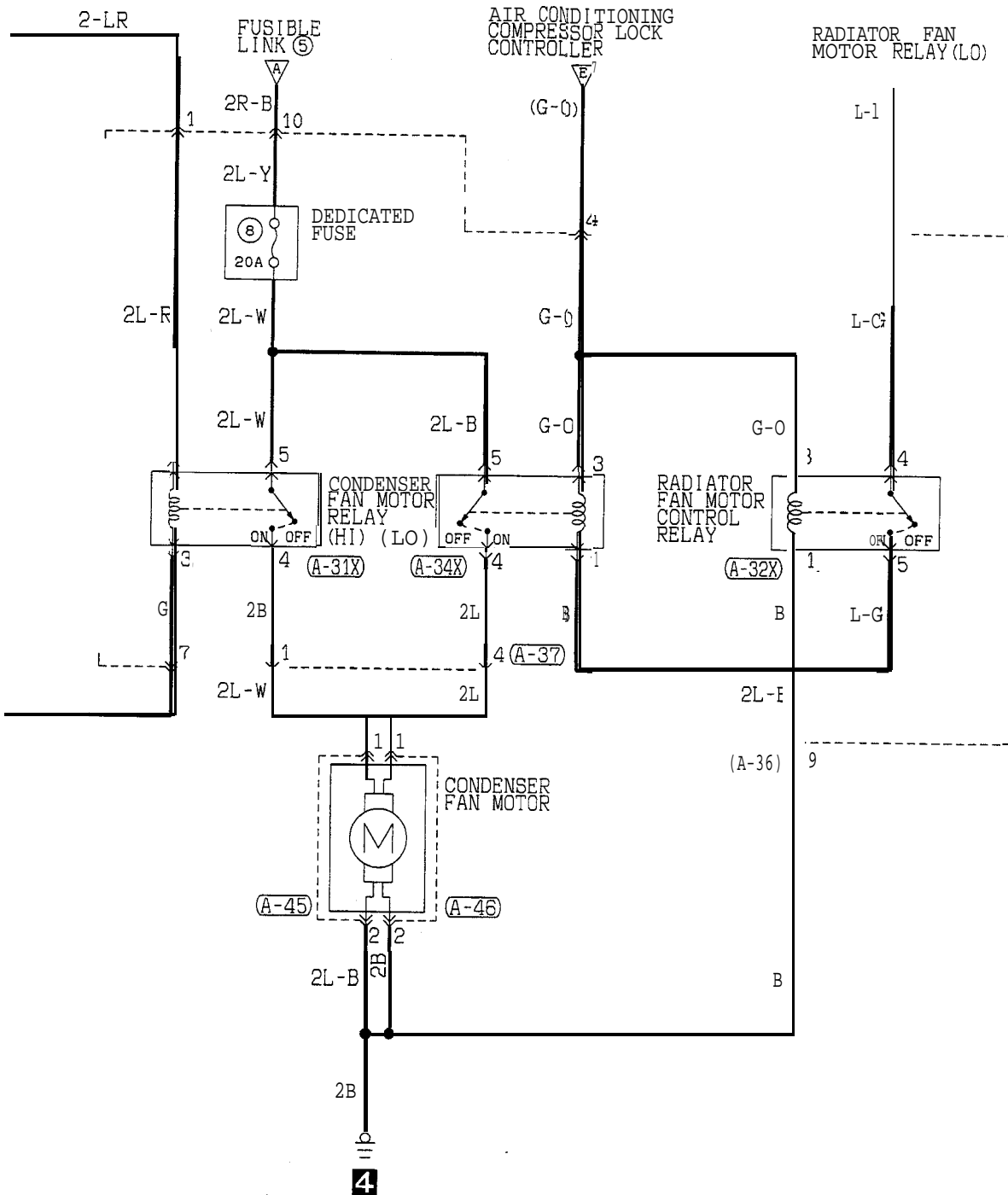

TSB Revision

MANUAL AIR CONDITIONING CIRCUIT (1992 MODEL) (CONTINUED)

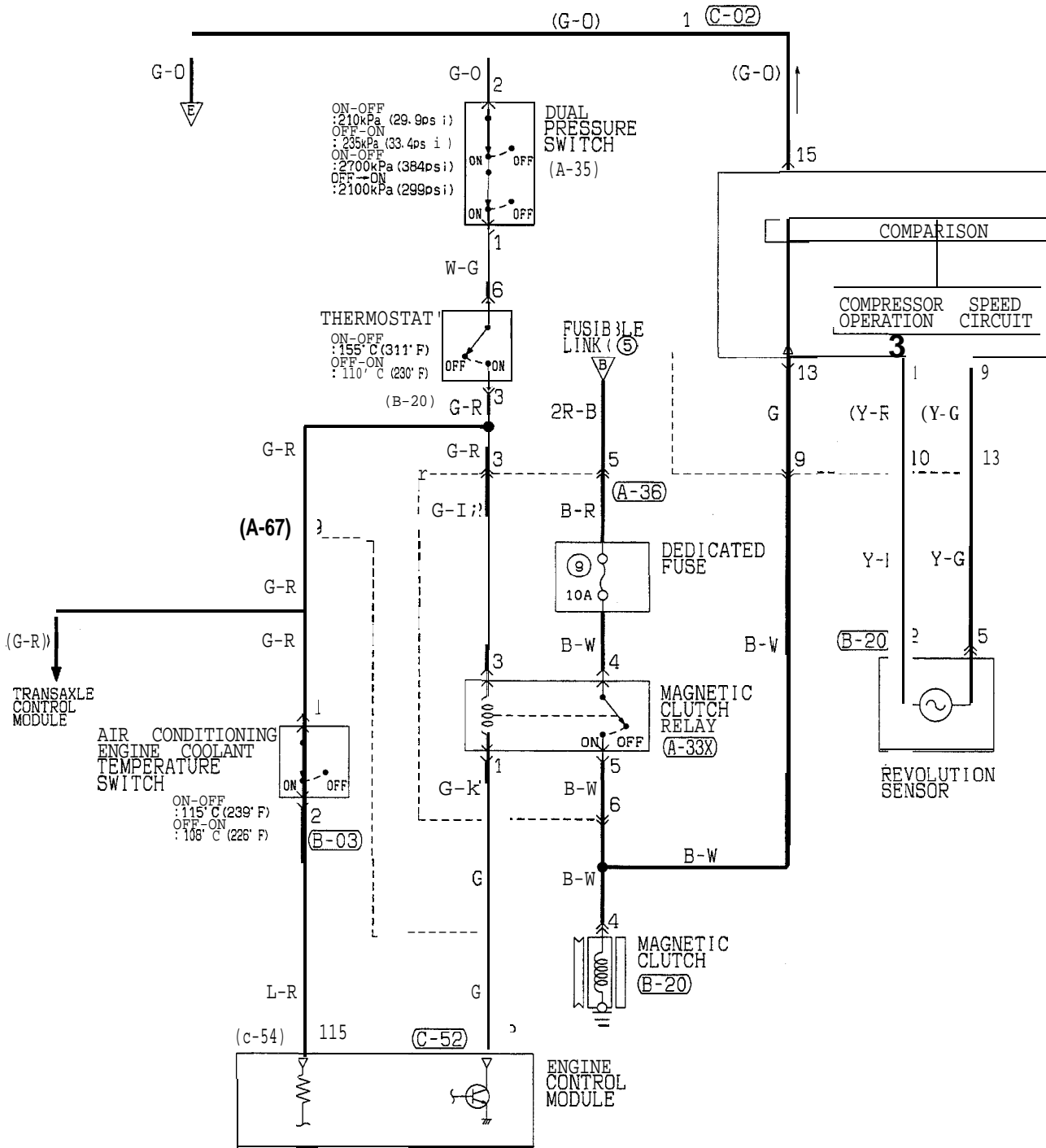

<b>(A-33X)</b> 1 2 3 4 5	<b>(A-35)</b> 1 2	<b>(A-36)</b> 1 2 3 4 5 6 7 8 9 10	<b>(A-67)</b> 1 2 3 4 5 6 7 8 9 10 11 12	<b>(B-03)</b> 1 2	<b>(B-20)</b> 1 2 3 4 5 6	<b>(C-02)</b> 1 2 3 4 5 6 7 8 9 10 11 12 13 14 15 16 17 18 19	<b>(c-52)</b> 1 2 3 4 5 6 7 8 9 10 11 12 13 14 15 16 17 18 19 20 21 22 23 24 25 26
<b>(C-54)</b> 101 102 103 104 105 106 107 108 109 110 111 112 113 114 115 116							

TSB Revision

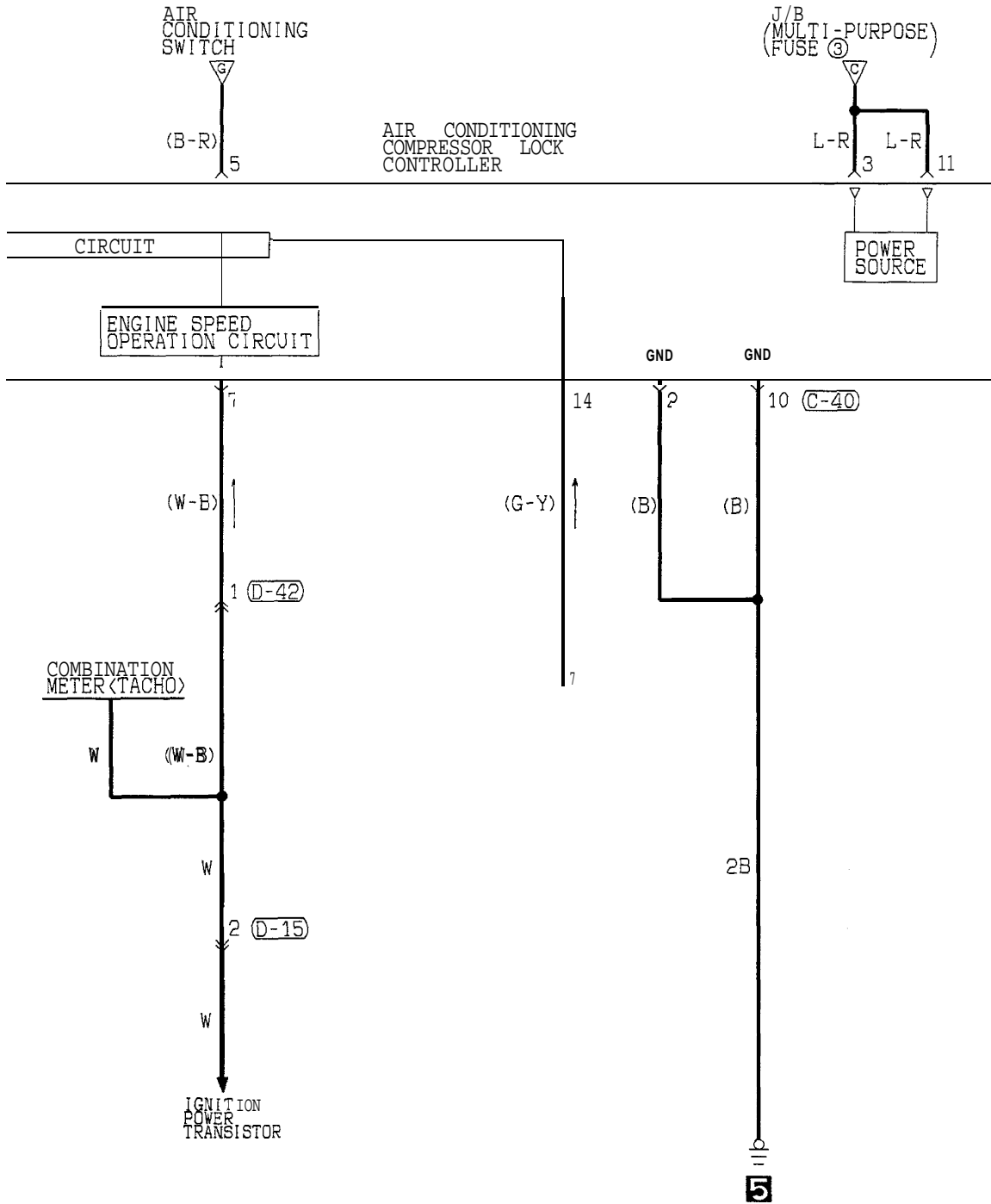

C-40

1	2	3	4	5	6	7	8
9	10	11	12	13	14	15	16

D-15

1	2	3	4
5	6	7	8

D-42

1	2	3	4	5	6	7	8	9	10
11	12	13	14	15	16	17	18	19	20
21	22								

TSB Revision

MANUAL AIR CONDITIONING CIRCUIT (1992 MODEL) (CONTINUED)

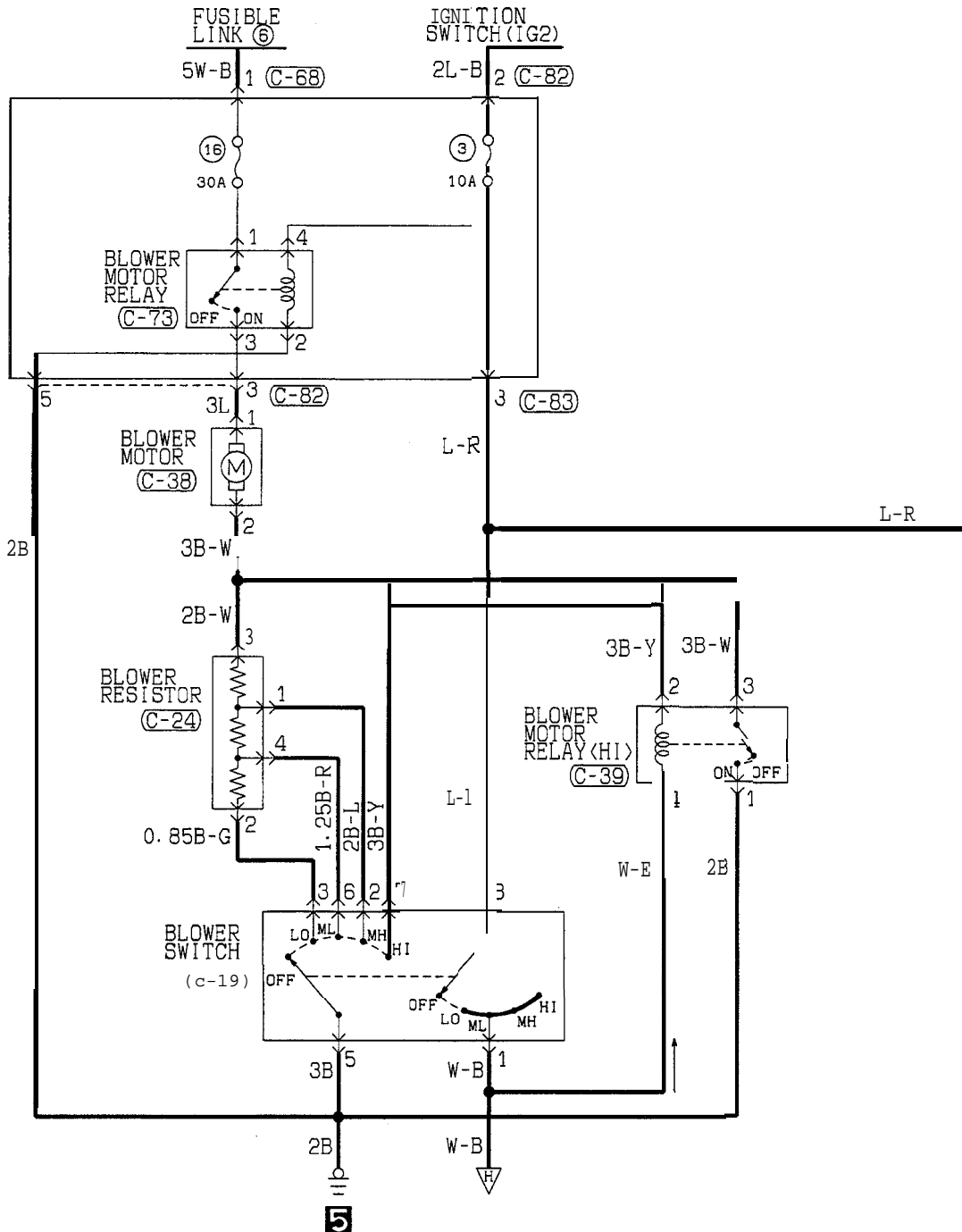

- (c-19) (C-24) (C-38) (C-39) (C-68) (c-73) (C-82) (C-83)
- |   |   |   |   |
|---|---|---|---|
| 1 | 2 | 3 | 4 |
| 5 | 6 | 7 | 8 |
- |   |   |
|---|---|
| 1 | 2 |
| 3 | 4 |
- |   |
|---|
| 1 |
|---|
- |   |   |
|---|---|
| 1 | 2 |
| 3 | 4 |
- |   |   |   |   |
|---|---|---|---|
| 1 | 2 | 3 | 4 |
| 5 | 6 | 7 | 8 |
- |    |    |   |   |    |
|----|----|---|---|----|
| 1  | 2  | 3 | 4 | 5  |
| 6  | 7  | 8 | 9 | 10 |
| 11 | 12 |   |   |    |

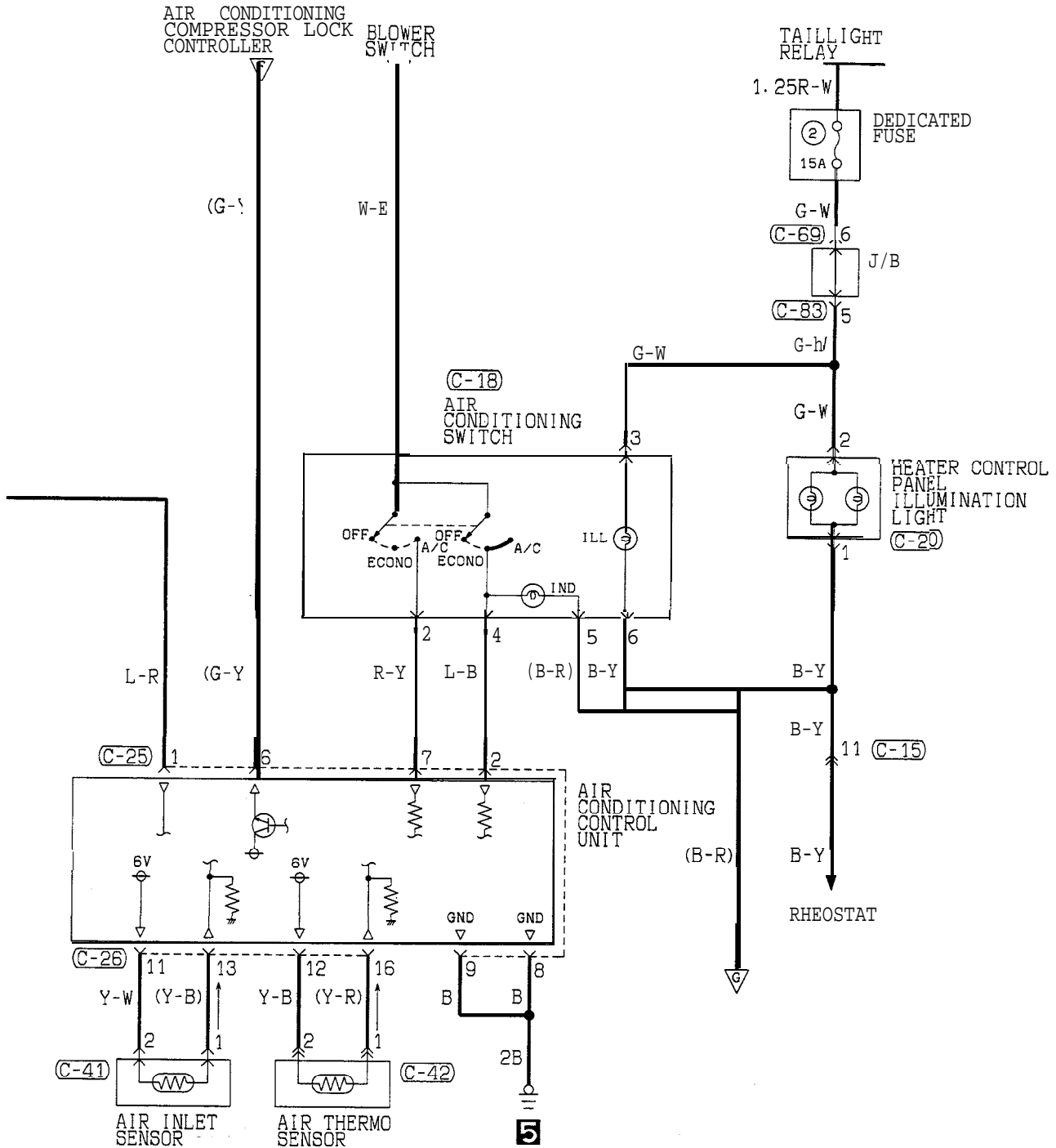

(C-15)

1	2	3	4	5
6	7	8	9	10
11	12	13	14	15

(C-18)

1	2
3	4

(C-20)

1
---

(C-25)

1	2	3	4	5
6	7	8	9	10
11	12	13	14	15

(C-26)

11	12
13	14

(C-41)

1	2
---	---

(C-42)

1
2

(C-69)

1	2	3	4
5	6	7	8

(C-83)

1	2	3	4	5
6	7	8	9	10
11	12	13	14	15

TSB Revision

MANUAL AIR CONDITIONING CIRCUIT (1993 MODELS)

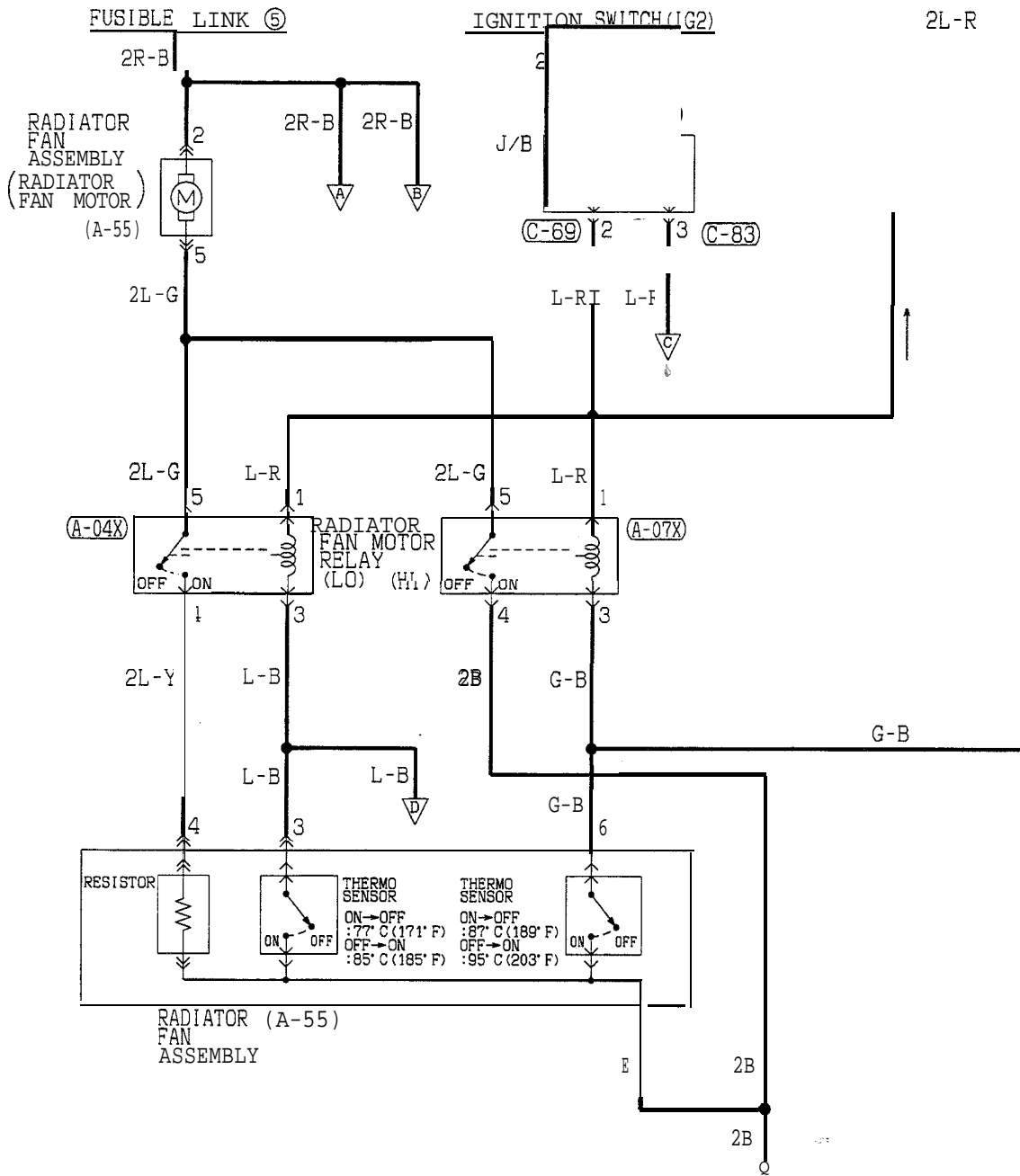

6

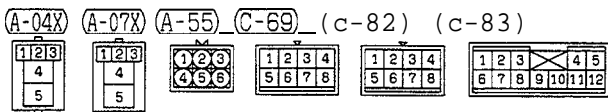

TSB Revision

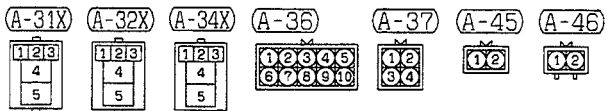
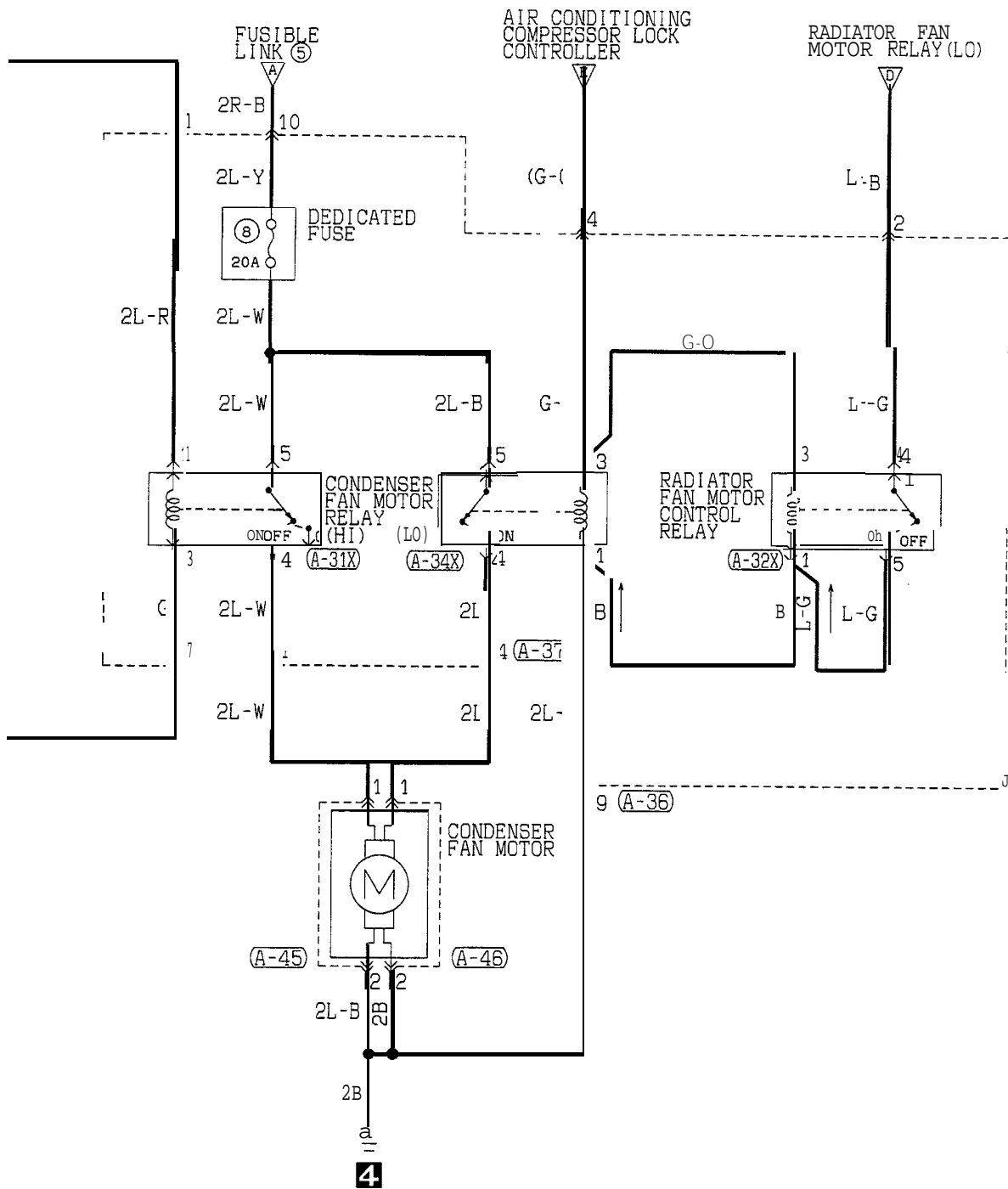



MANUAL AIR CONDITIONING CIRCUIT (1993 MODELS) (CONTINUED)

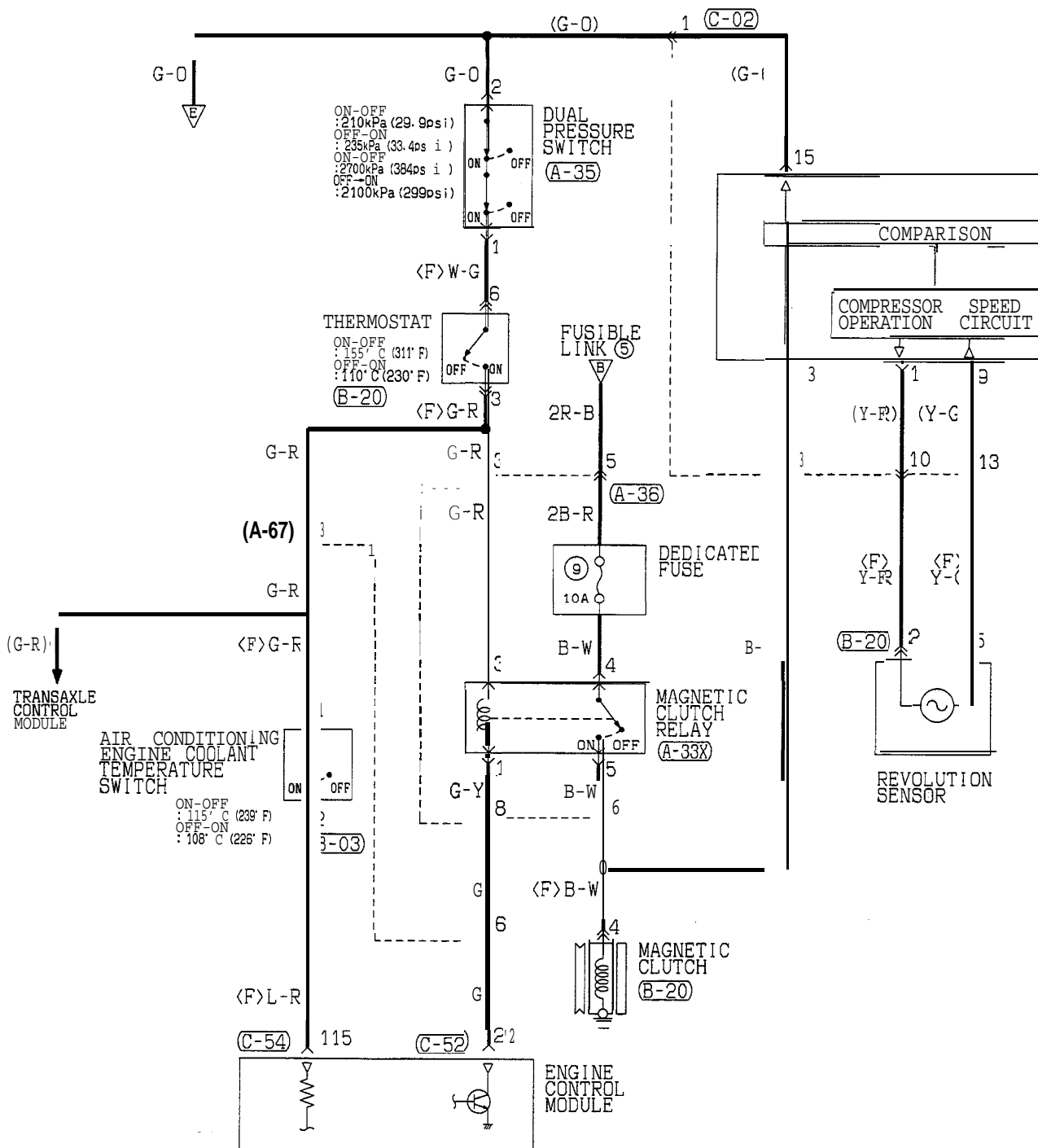

A-33X

1	2	3
4		
5		

A-35

1	2
---	---

A-36

1	2	3	4	5
6	7	8	9	10

A-67

1	2	3	4	5	6
7	8	9	10	11	12

B-03

1	2
---	---

B-20

1	2	3
4	5	6

C-02

1	2	3	4	5	6	7	8			
9	10	11	12	13	14	15	16	17	18	19

C-52

1	2	3	4	5	6	7	8	9	10	11	12	13
14	15	16	17	18	19	20	21	22	23	24	25	26

C-54

10	11	102	103	104	105	106	107	108
109	110	111	112	113	114	115	116	

TSB Revision

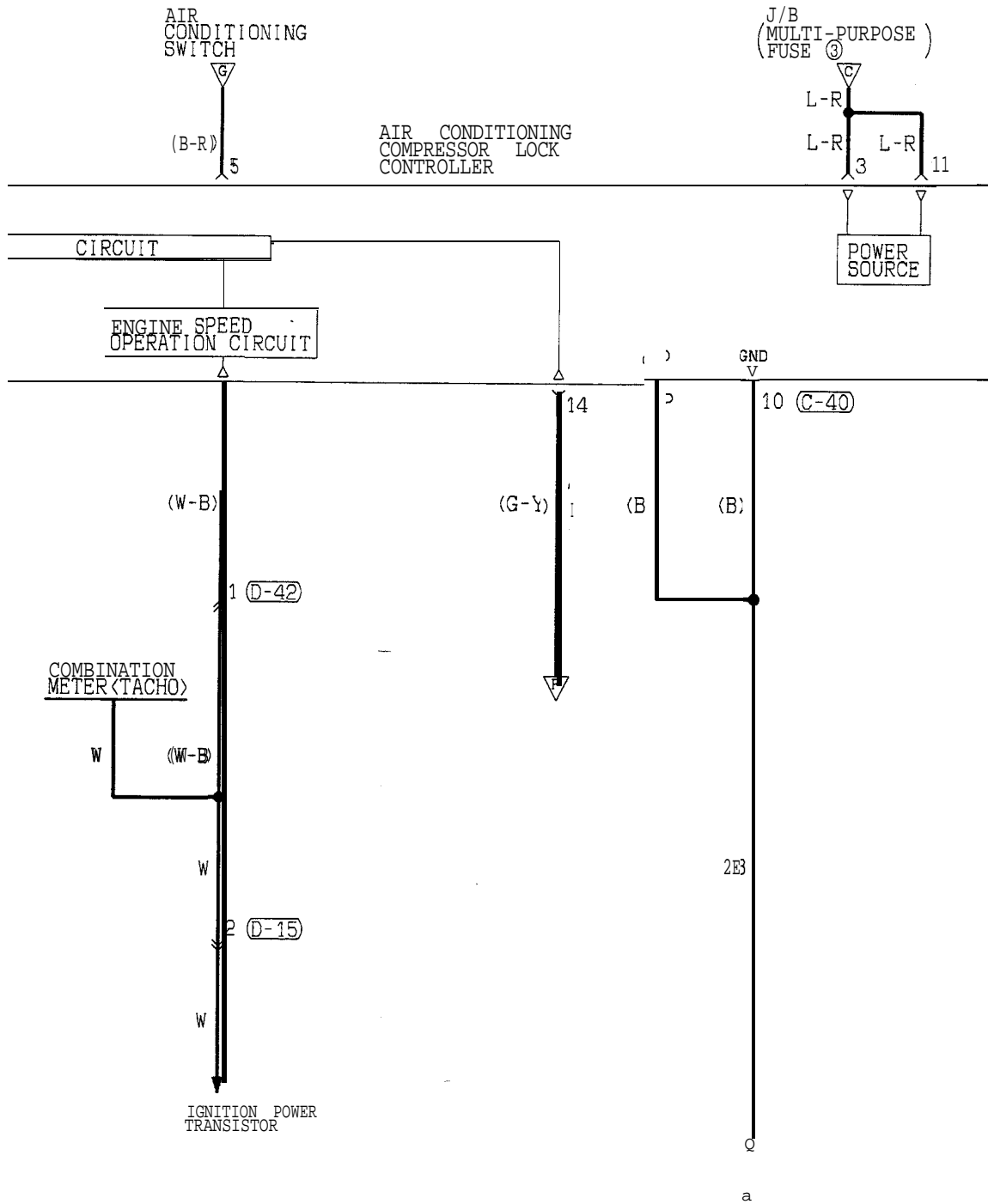

C-40

1	2	3	4	5	6	7	8
9	10	11	12	13	14	15	16

D-15

1	2	3	4
5	6	7	8

D-42

1	2	3	4	5	6	7	8	9	10
11	12	13	14	15	16	17	18	19	20
21	22								

MANUAL AIR CONDITIONING CIRCUIT (1993 MODELS) (CONTINUED)

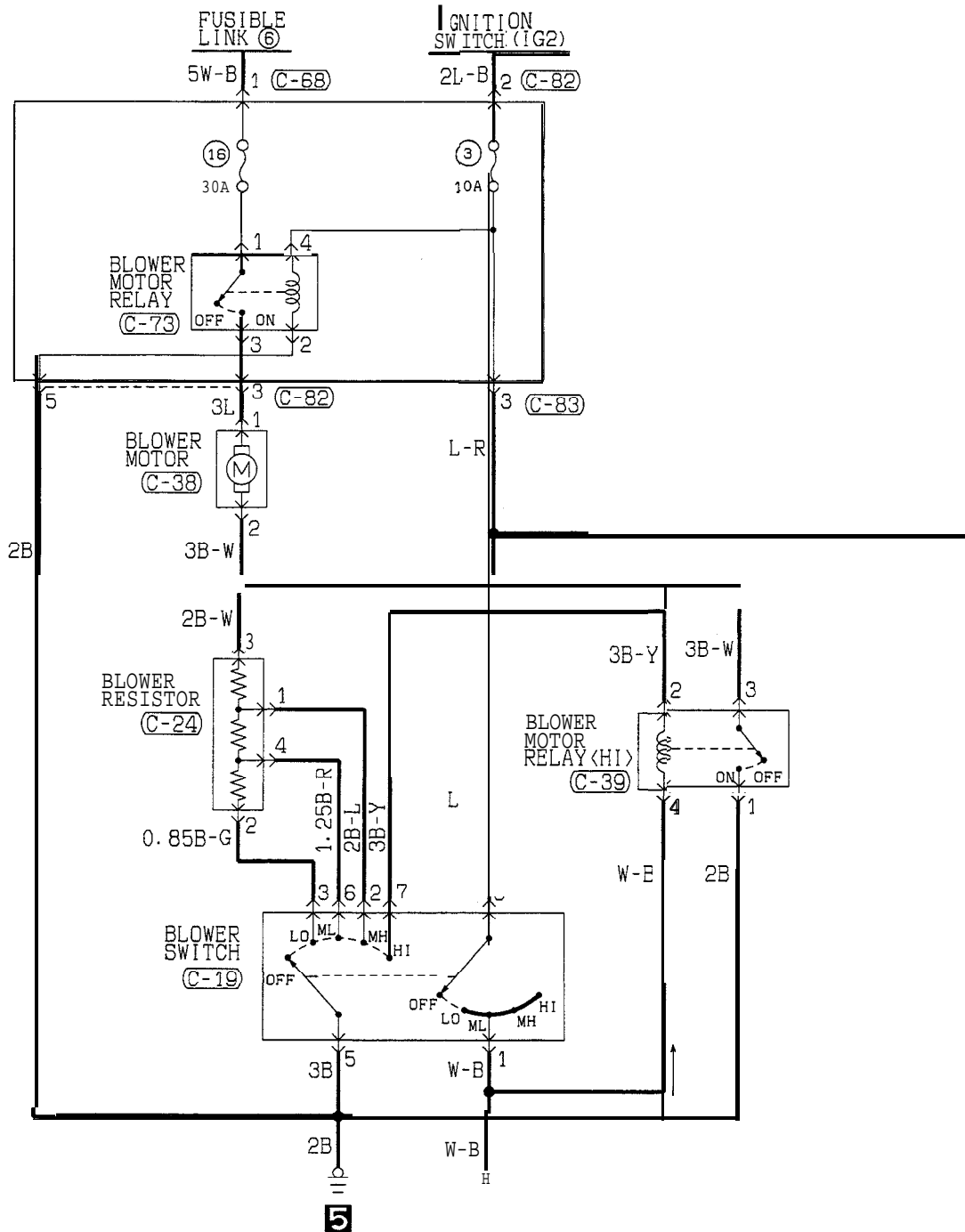

- (C-19)**  

1	2	3	4
5	6	7	8
- (C-24)**  

1	2
3	4
- (C-38)**  

1
2
- (C-39)**  

1	2
3	4
- (C-68)**  

1
---
- (C-73)**  

1	2
3	4
- (C-82)**  

1	2	3	4
5	6	7	8
- (C-83)**  

1	2	3	4	5
6	7	8	9	10
11	12			

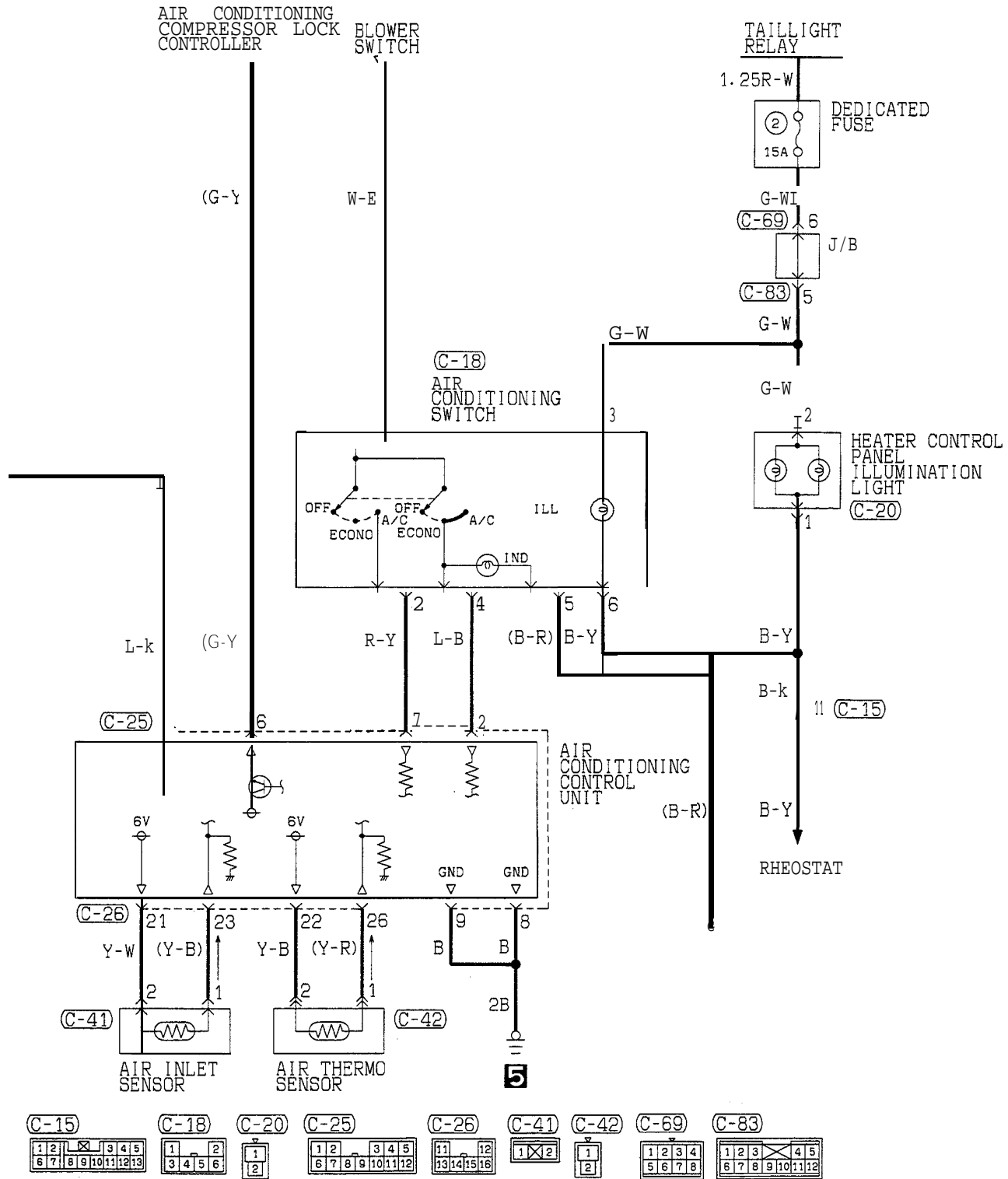

MANUAL AIR CONDITIONING CIRCUIT (1994, 1995 MODELS)

<NON TURBO> (FEDERAL)

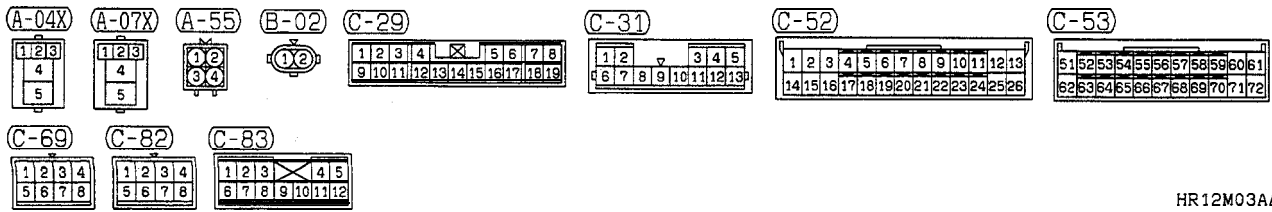
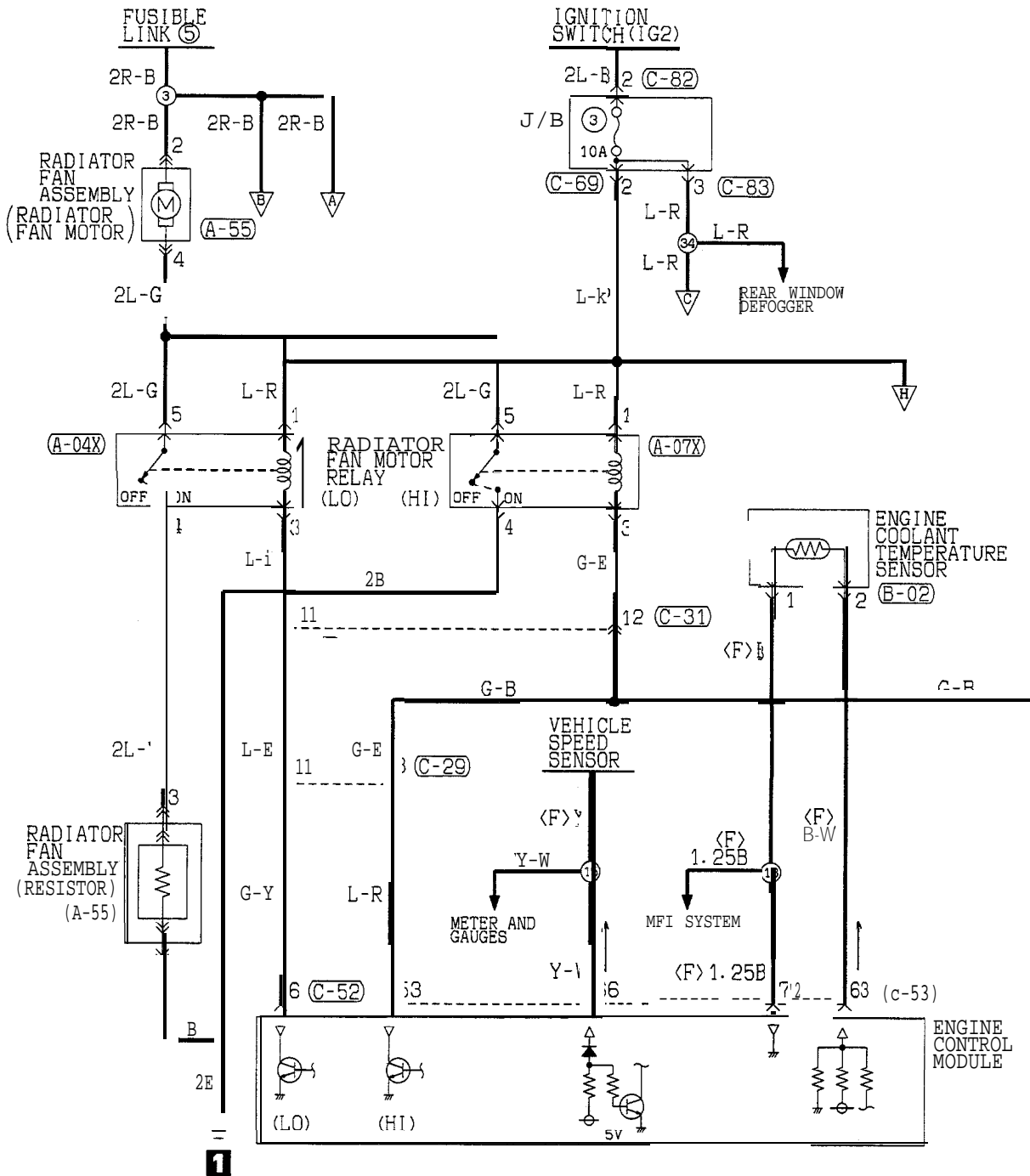

TSB Revision

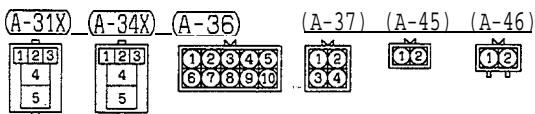
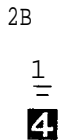
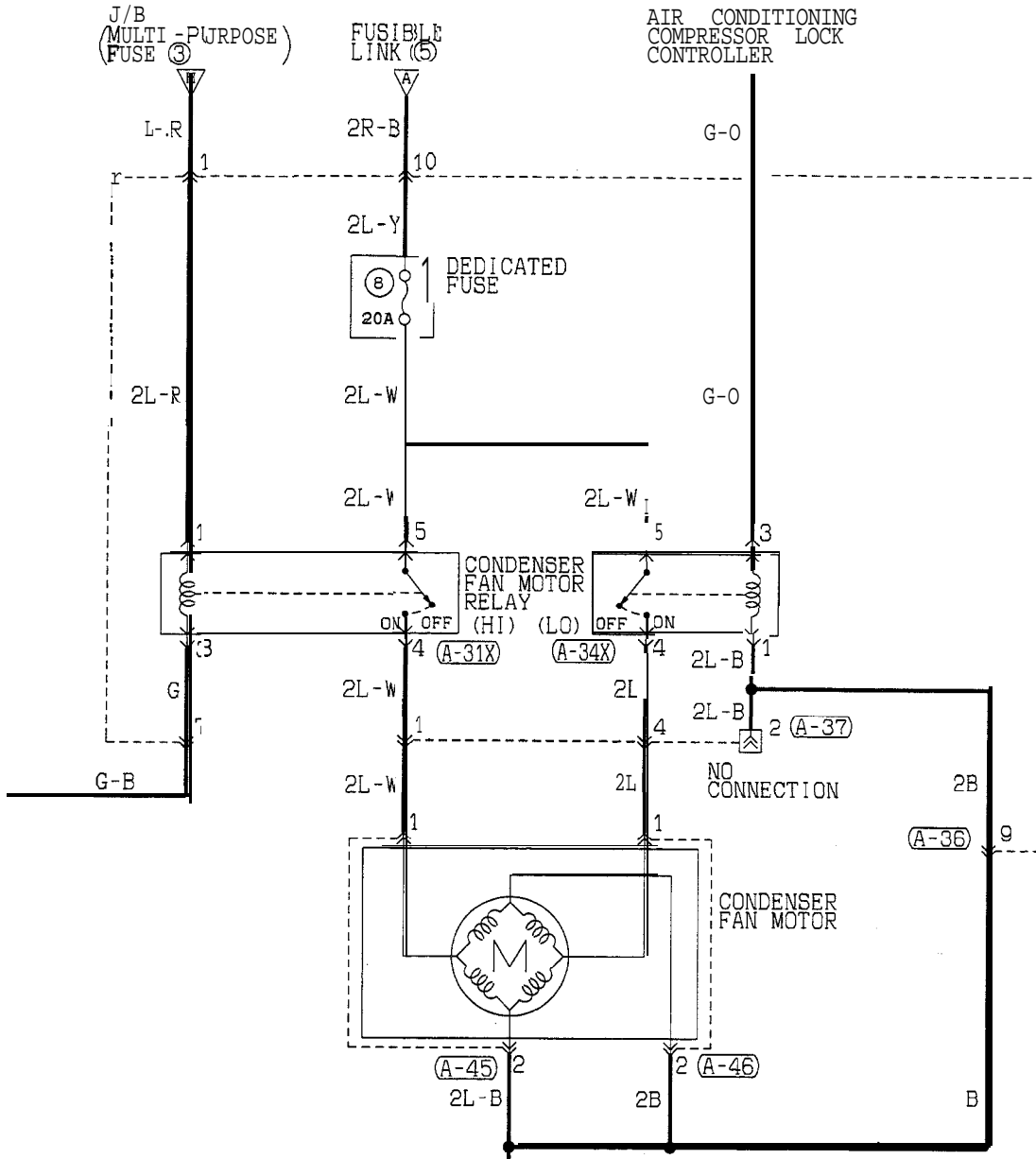

TSB Revision

MANUAL AIR CONDITIONING CIRCUIT (1994, 1995 MODELS) <NON TURBO> (FEDERAL) (CONTINUED)

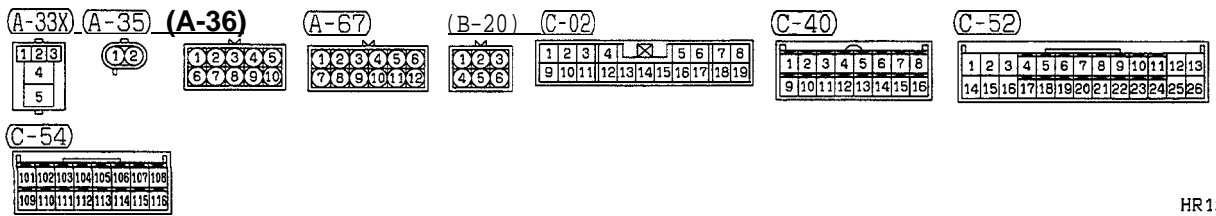
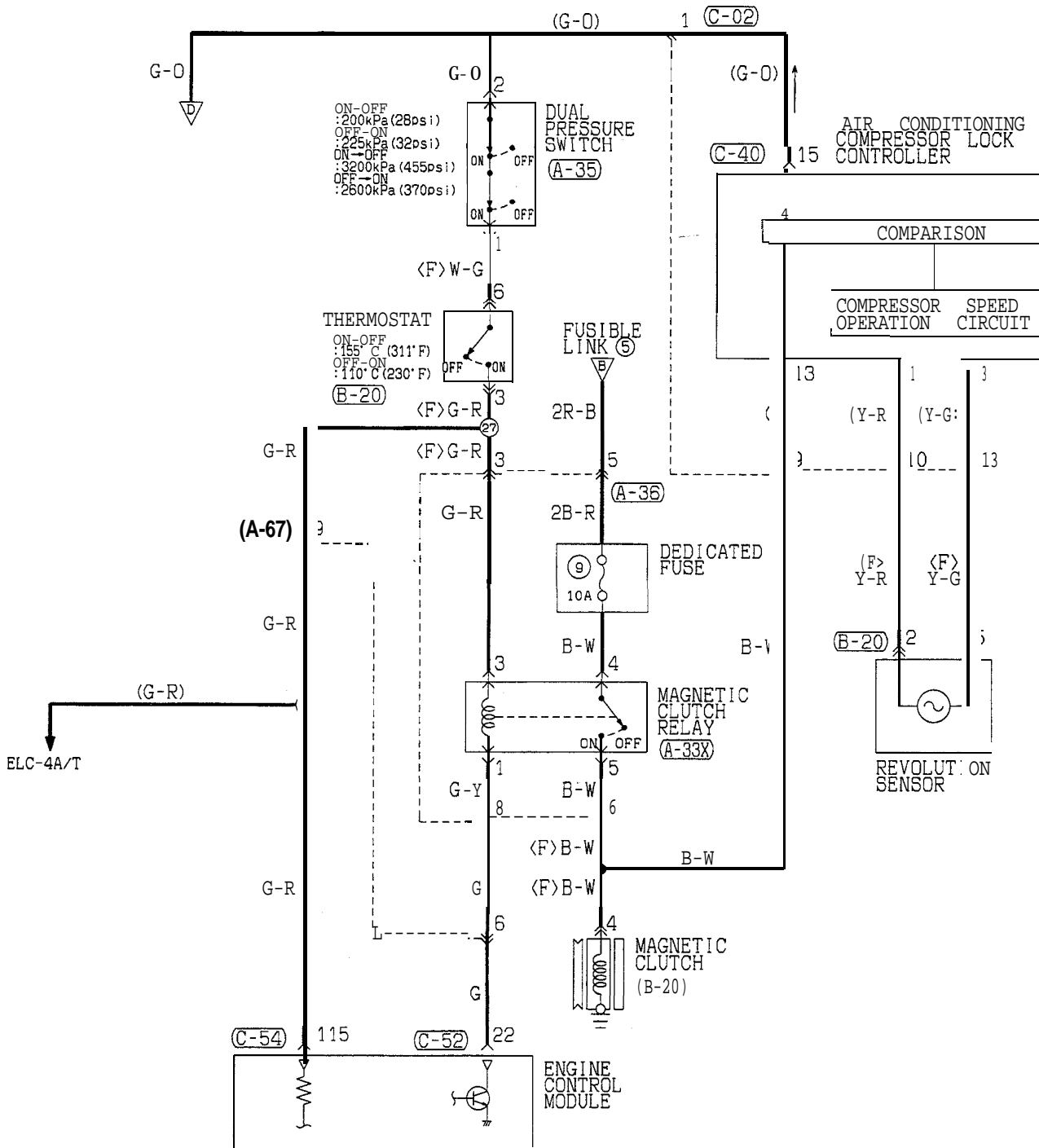

TSB Revision

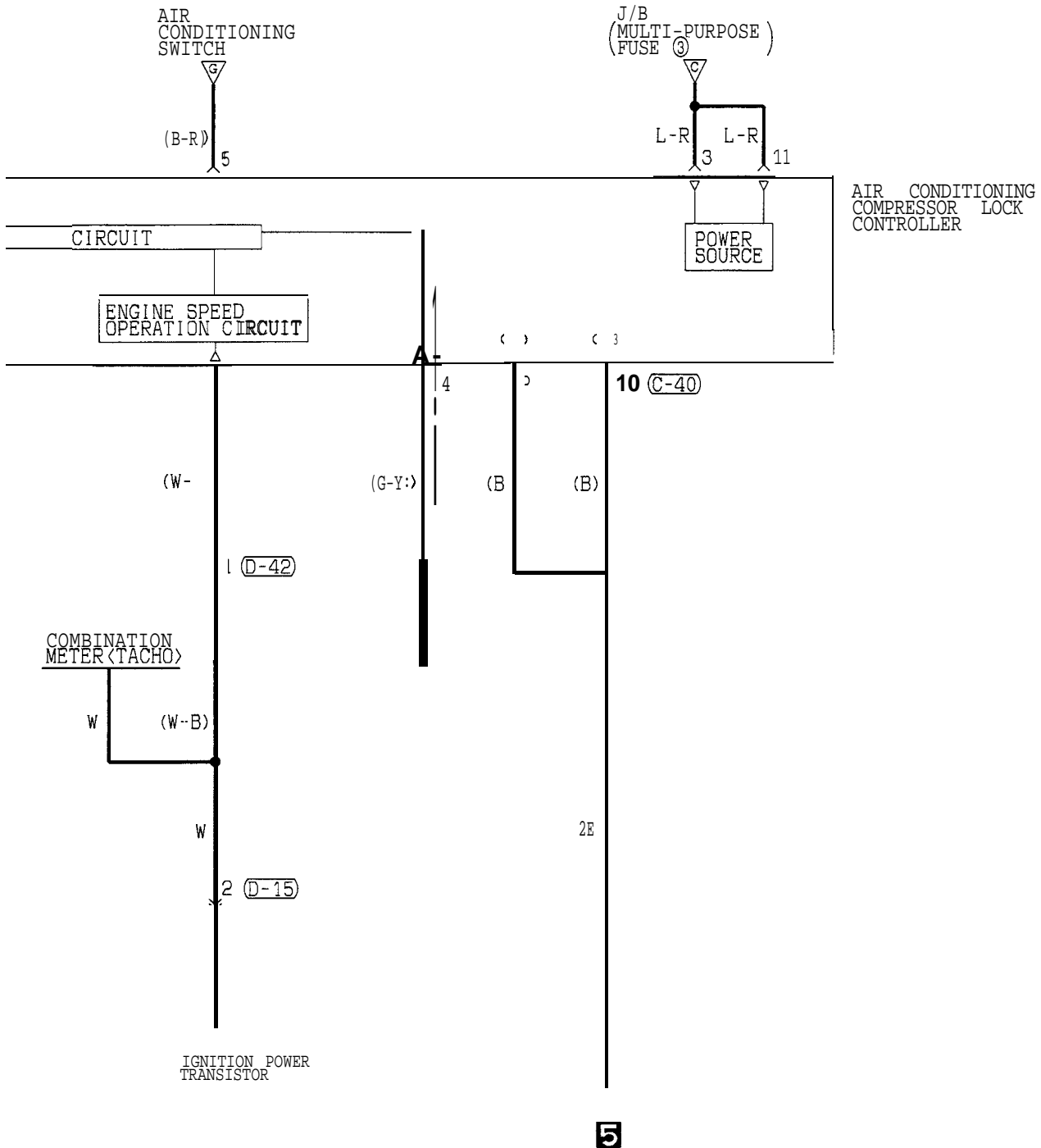

C-40

1	2	3	4	5	6	7	8
9	10	11	12	13	14	15	16

D-15

1	2	3	4
5	6	7	8

D-42

1	2	3	4	5	6	7	8	9	10
11	12	13	14	15	16	17	18	19	20



MANUAL AIR CONDITIONING CIRCUIT (1994, 1995 MODELS) <NON TURBO> (FEDERAL) (CONTINUED)

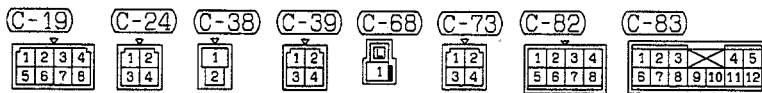
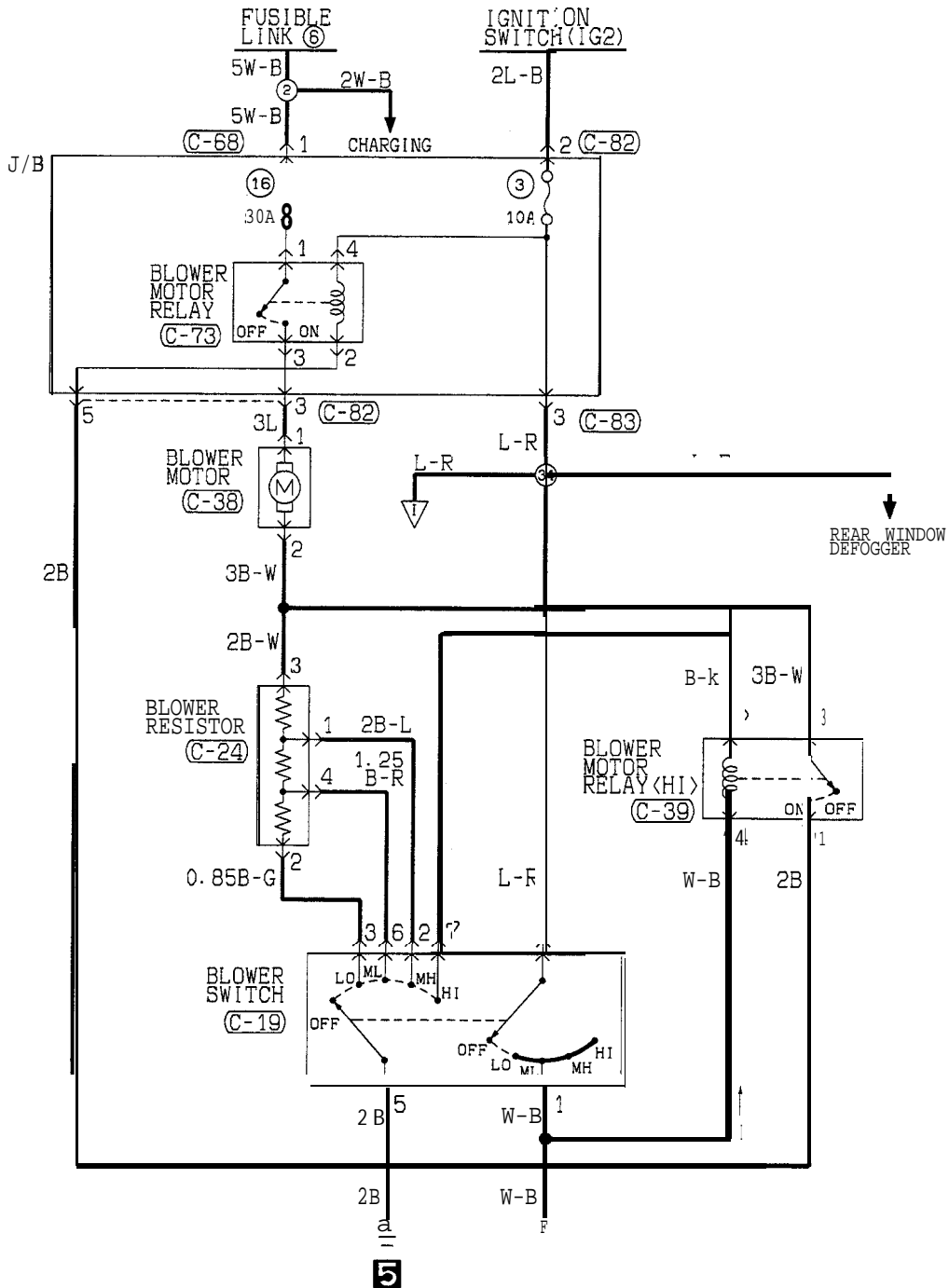

TSB Revision

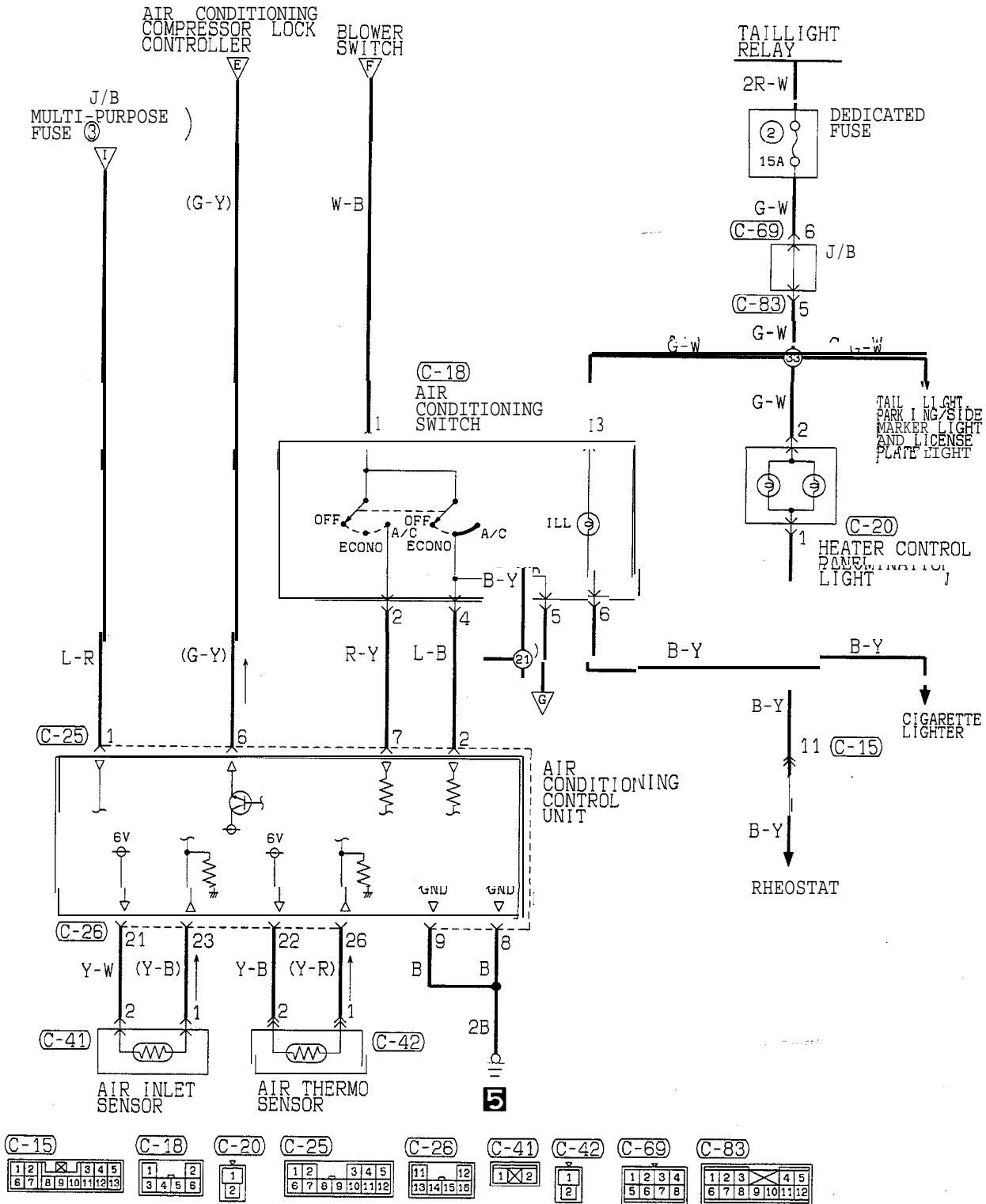

TSB Revision

MANUAL AIR CONDITIONING CIRCUIT (1994, 1995 MODELS)

<TURBO, NON TURBO (CALIFORNIA)>

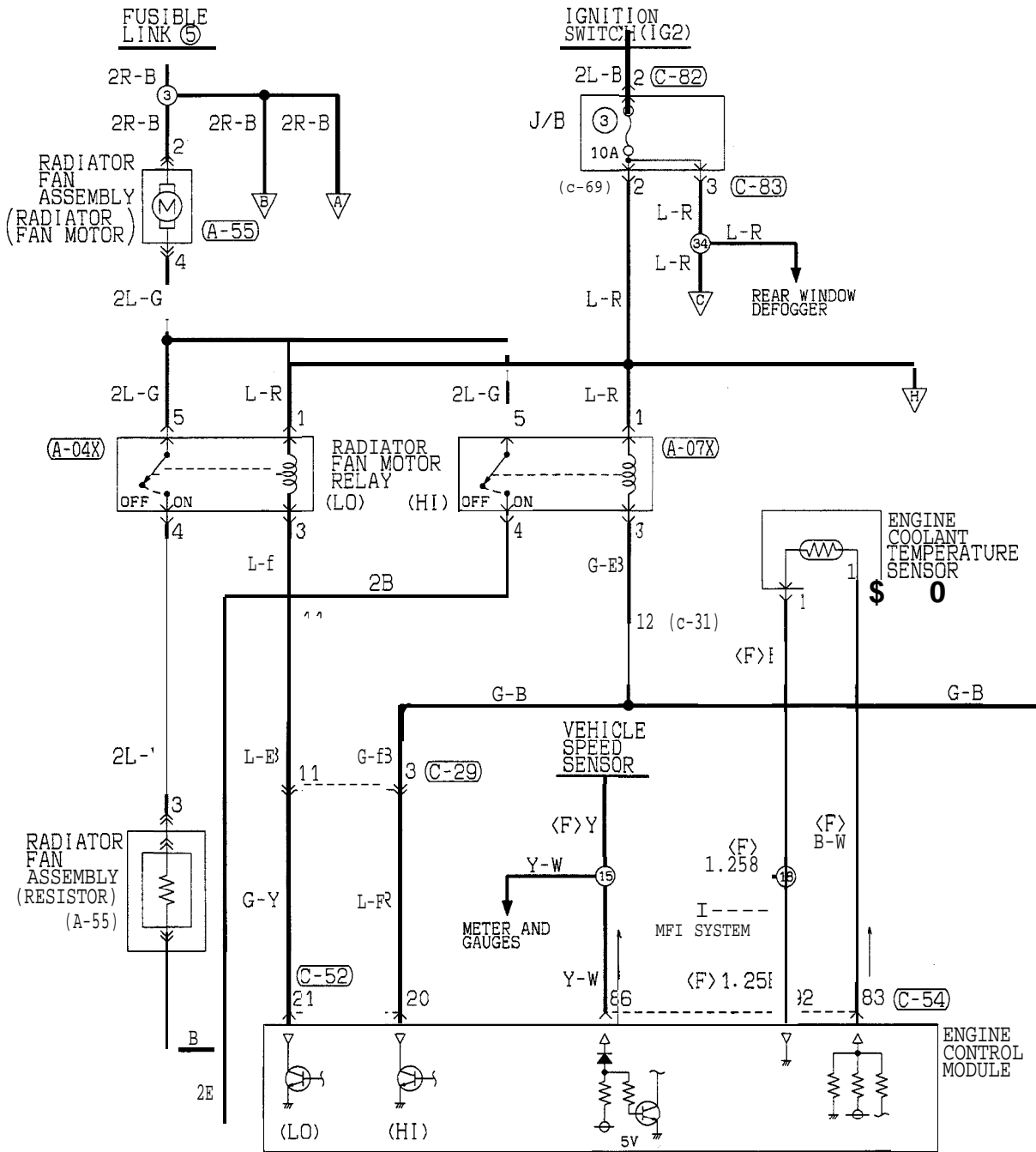

1

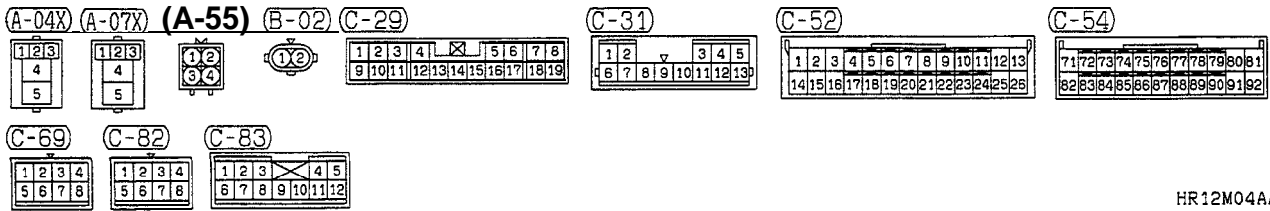

TSB Revision

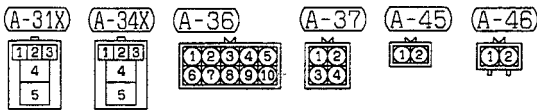
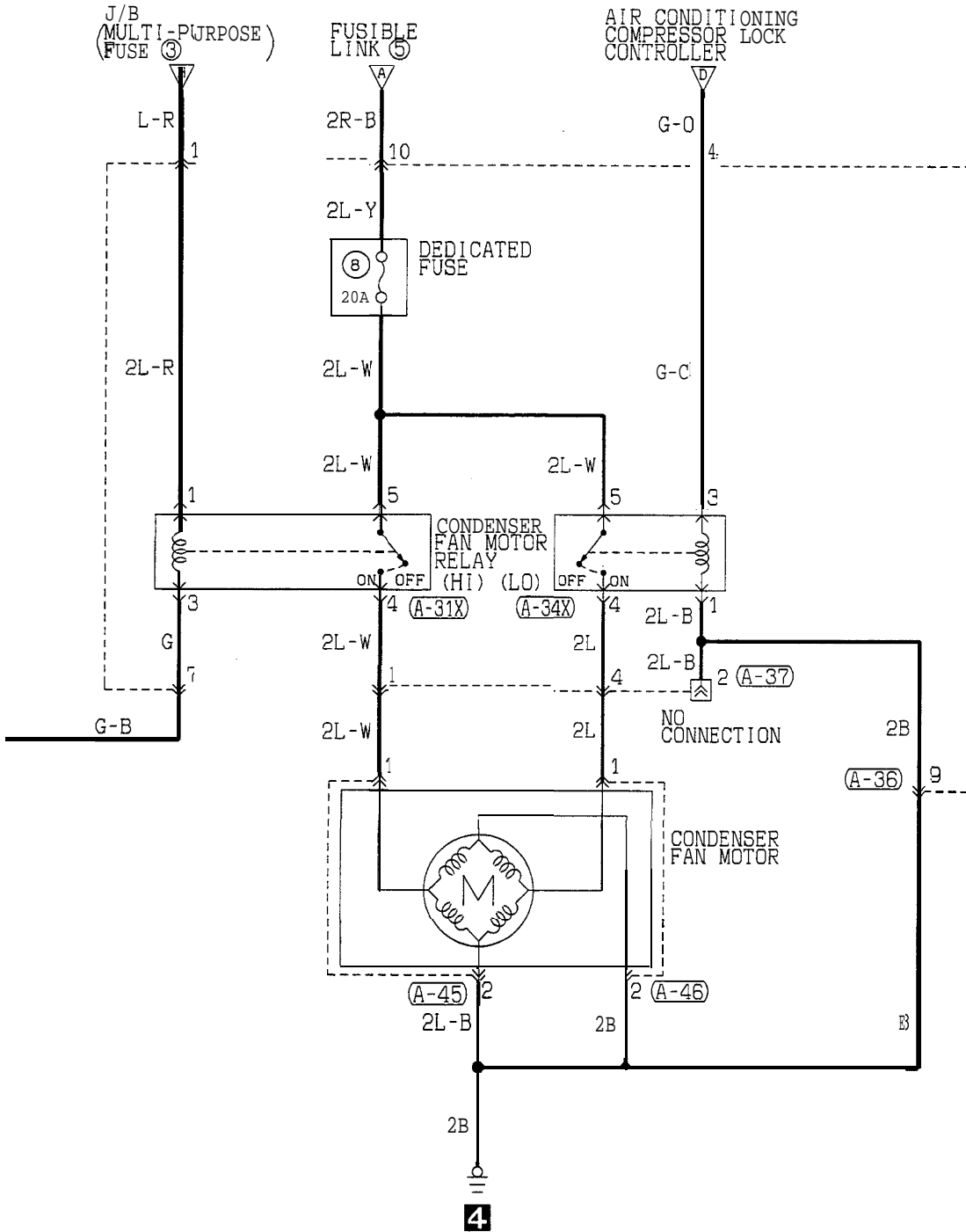

TSB Revision

MANUAL AIR CONDITIONING CIRCUIT (1994, 1995 MODELS)  
 <TURBO, NON TURBO (CALIFORNIA)> (CONTINUED)

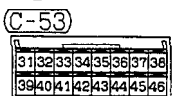
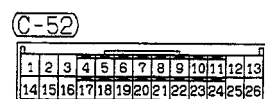
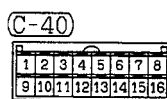
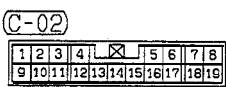
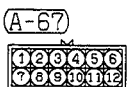
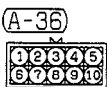
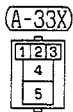
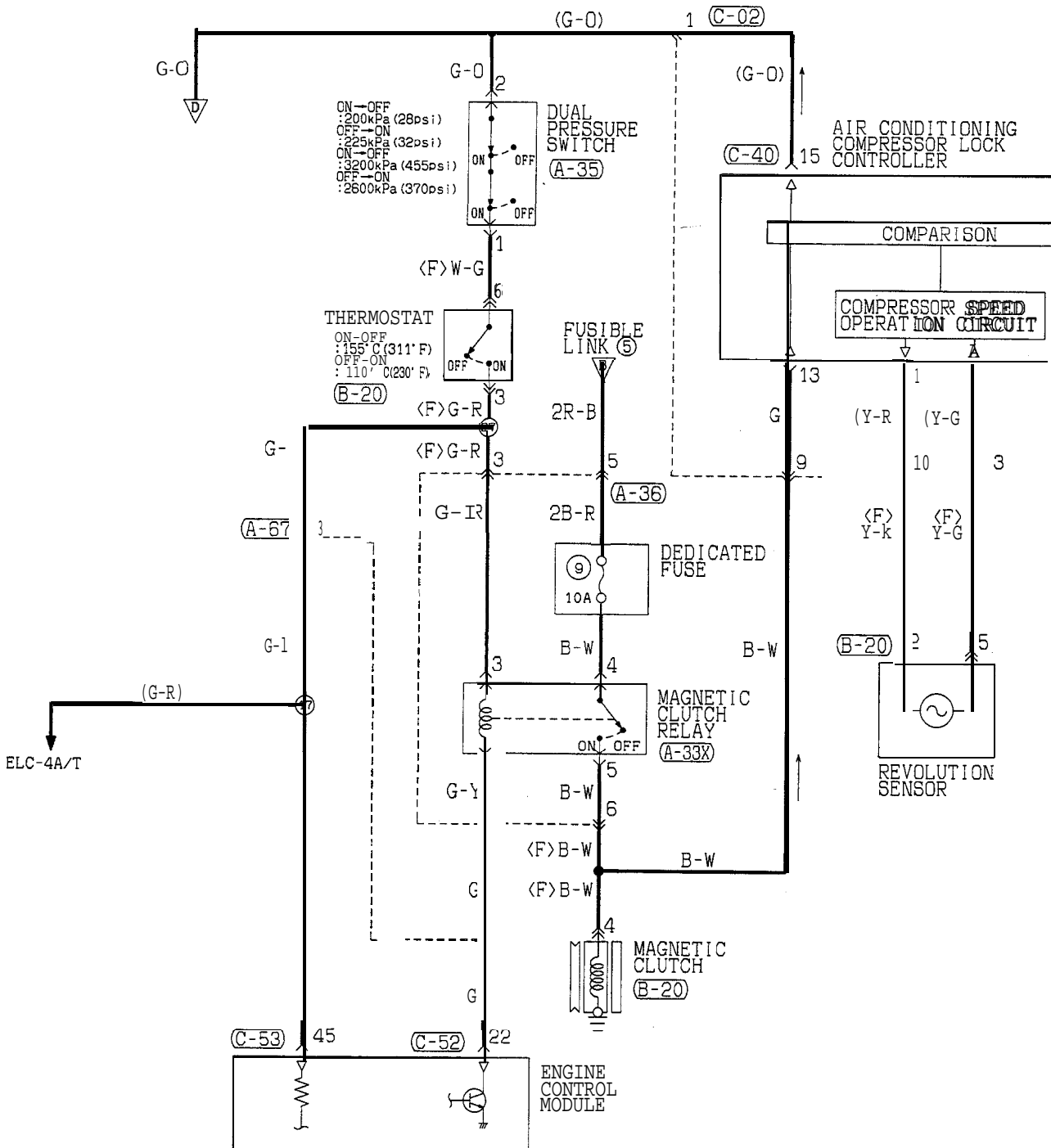

TSB Revision

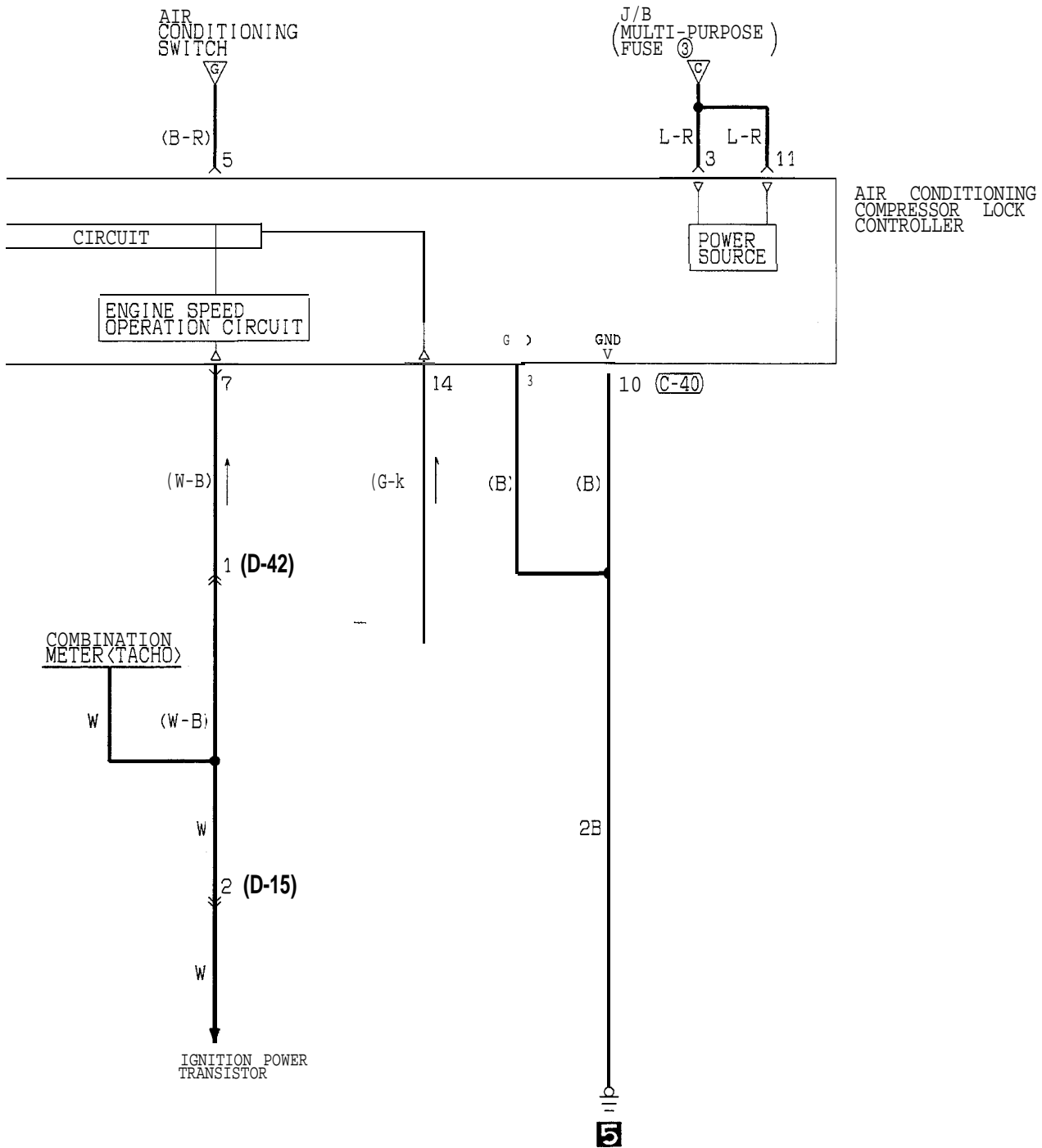

C-40

1	2	3	4	5	6	7	8
9	10	11	12	13	14	15	16

D-15

1	2	M	3	4	
5	6	7	8	9	10

D-42

1	2	3	4	5	M	6	7	8	9	10	
11	12	13	14	15	16	17	18	19	20	21	22

TSB Revision

MANUAL AIR CONDITIONING CIRCUIT (1994, 1995 MODELS)  
 <TURBO, NON TURBO (CALIFORNIA)> (CONTINUED)

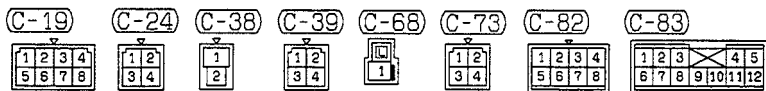
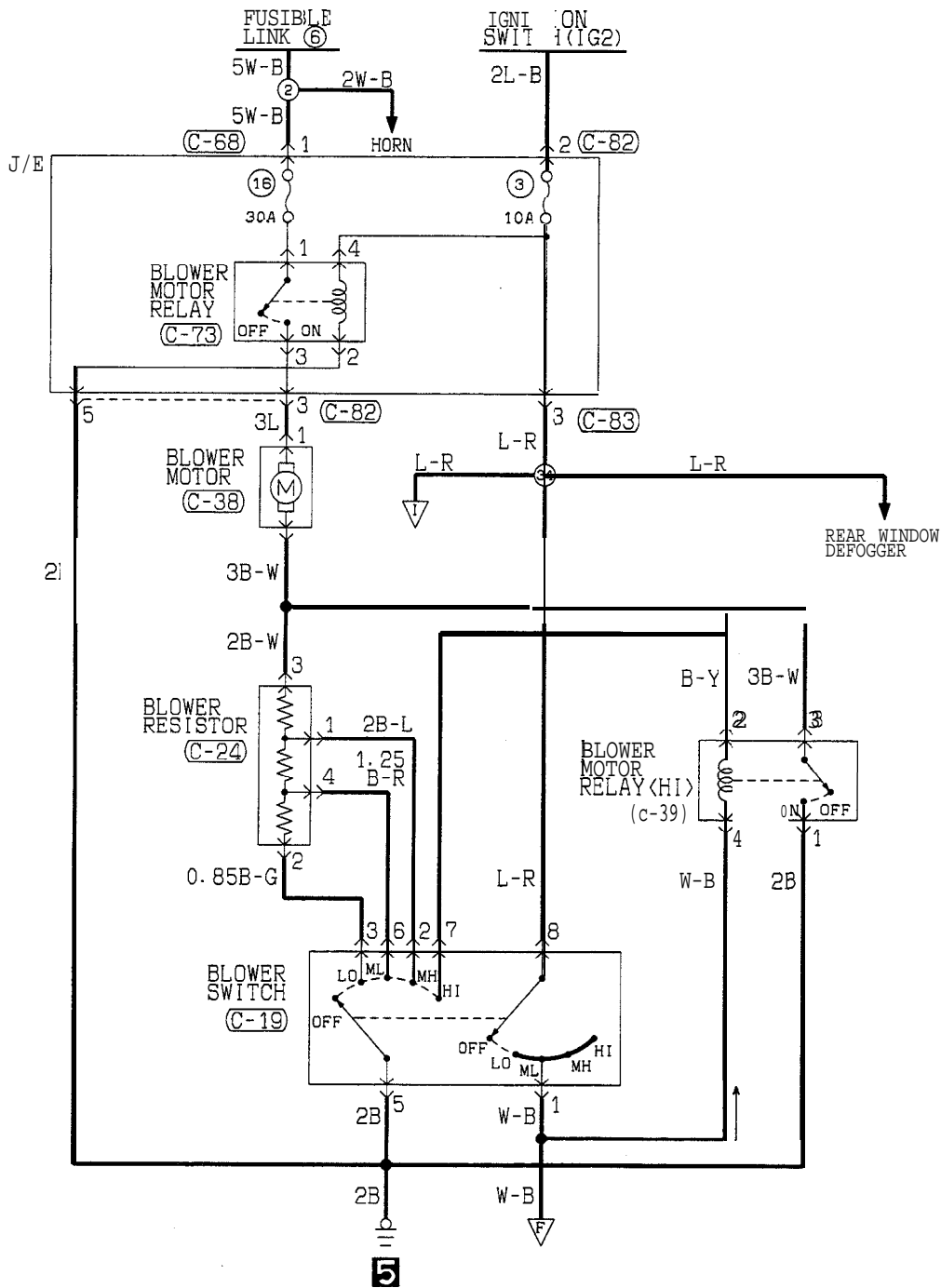

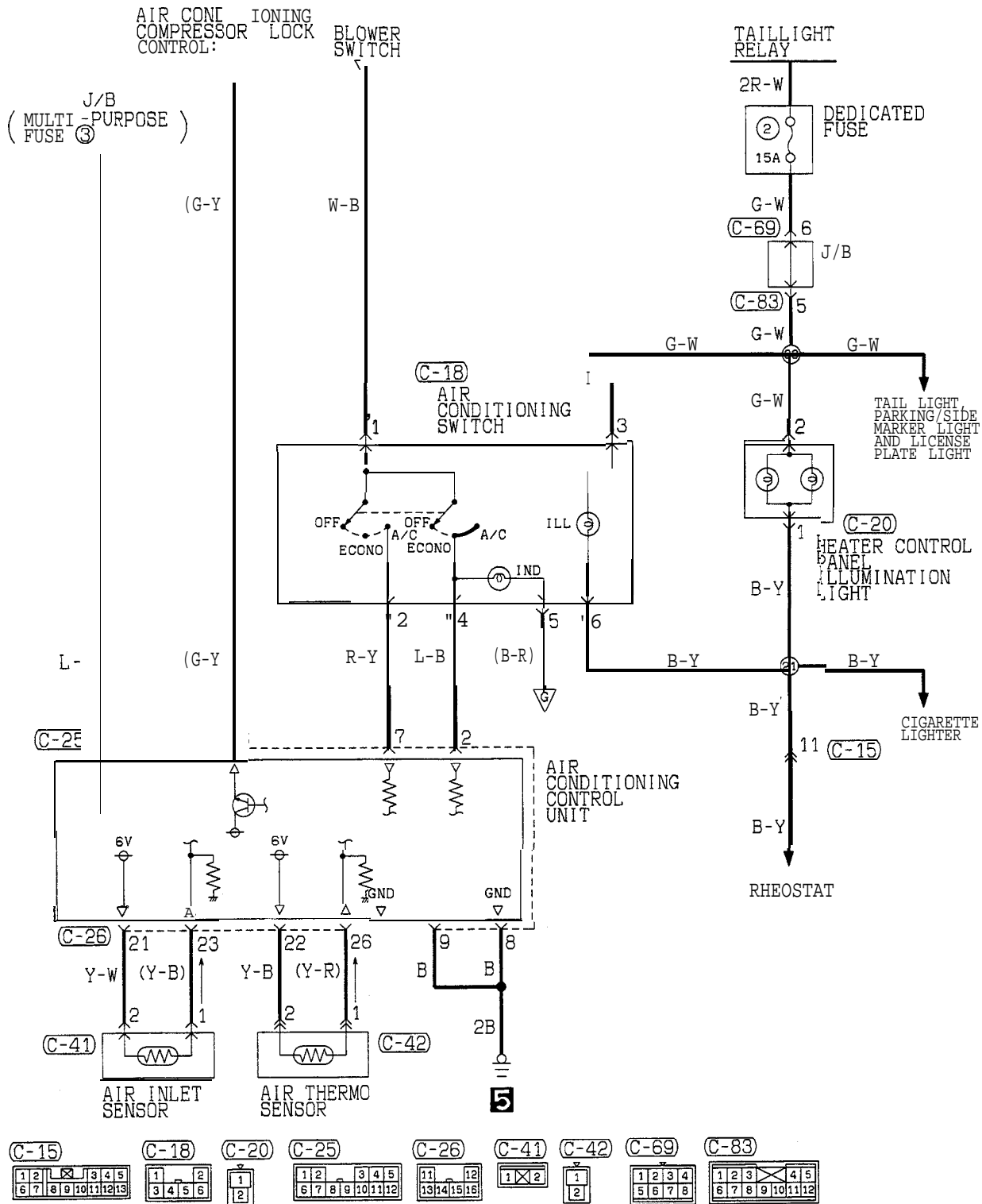



MANUAL AIR CONDITIONING CIRCUIT (FROM 1996 MODELS)

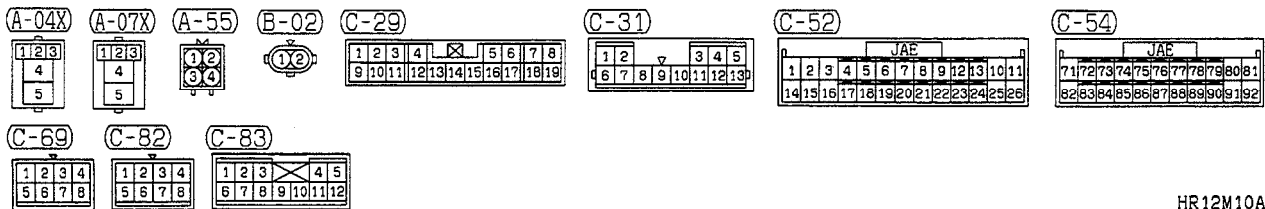
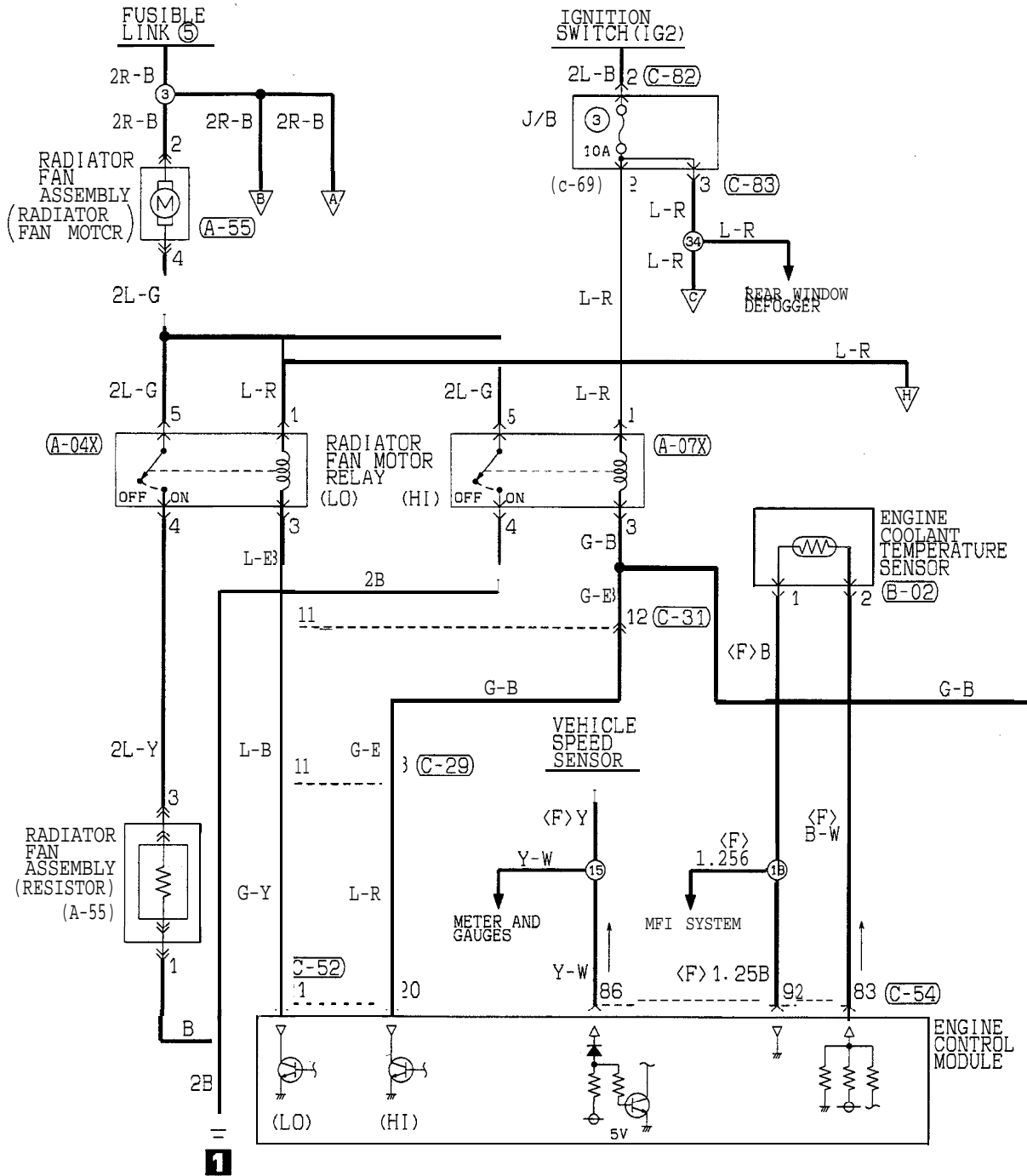

HR12M10AA

TSB Revision

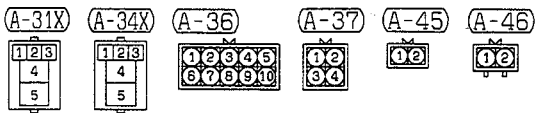
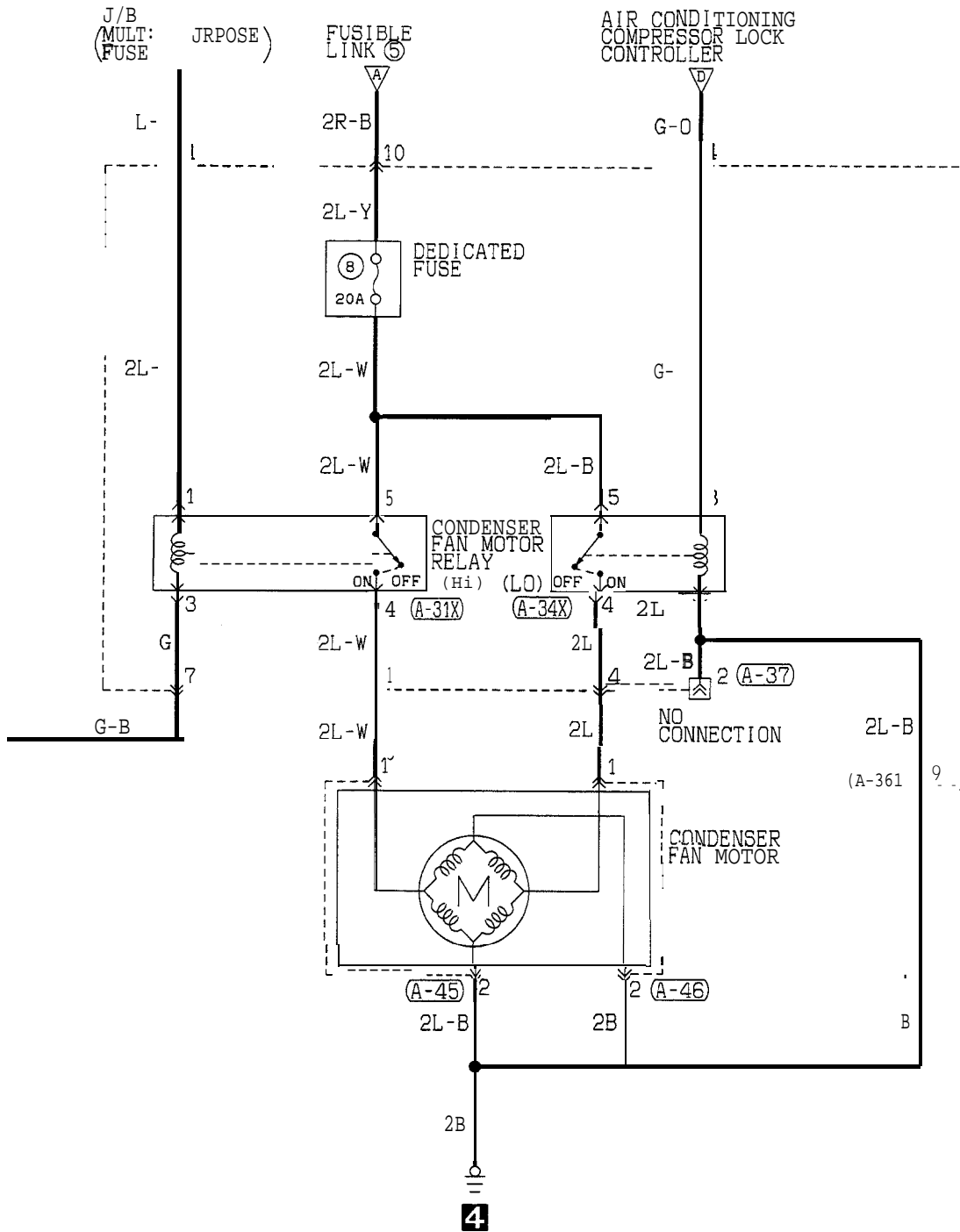

TSB Revision

MANUAL AIR CONDITIONING CIRCUIT (FROM 1996 MODELS) (CONTINUED)

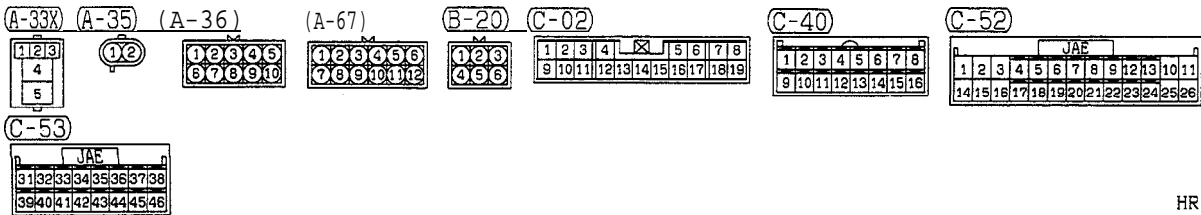
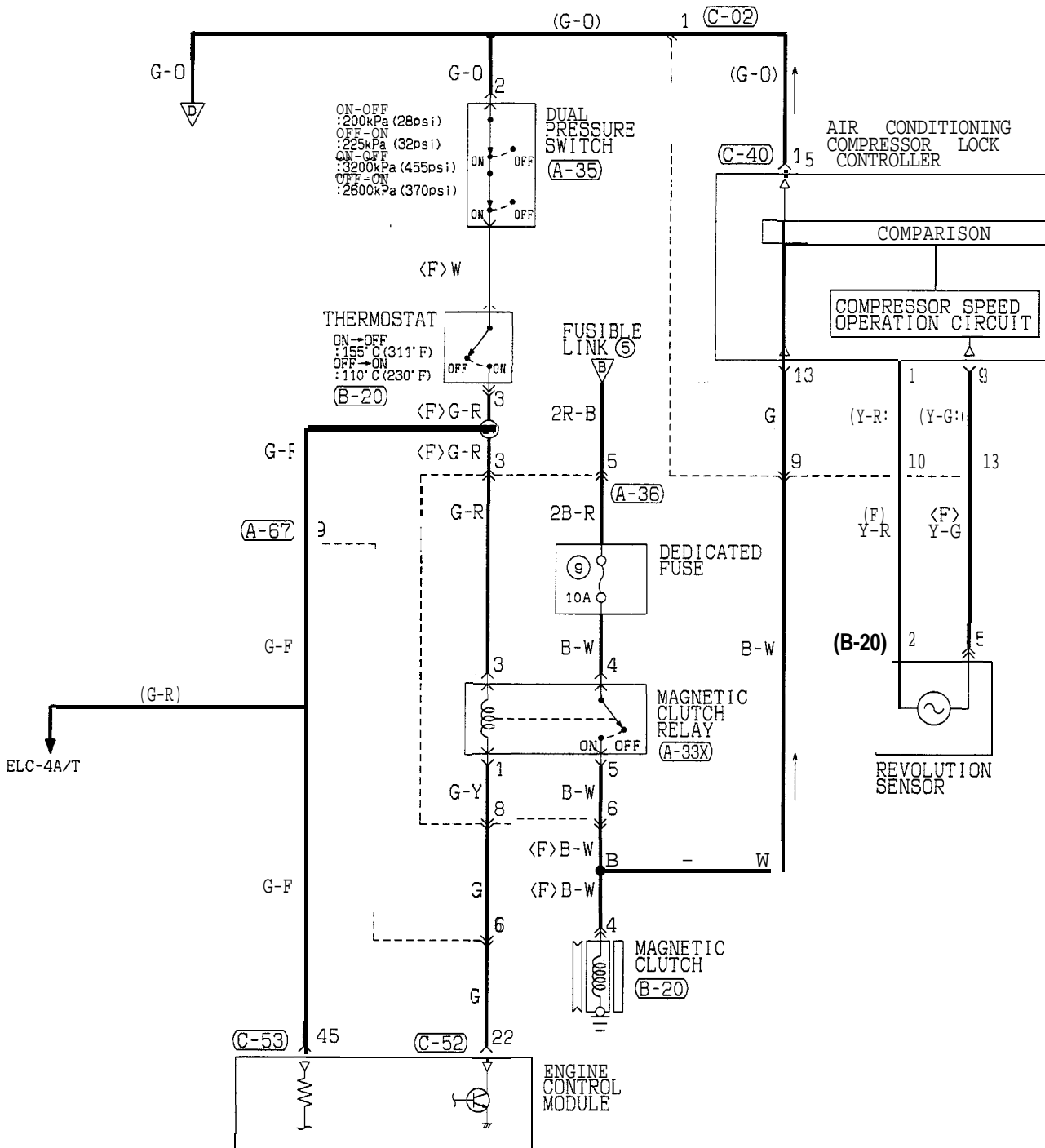

TSB Revision

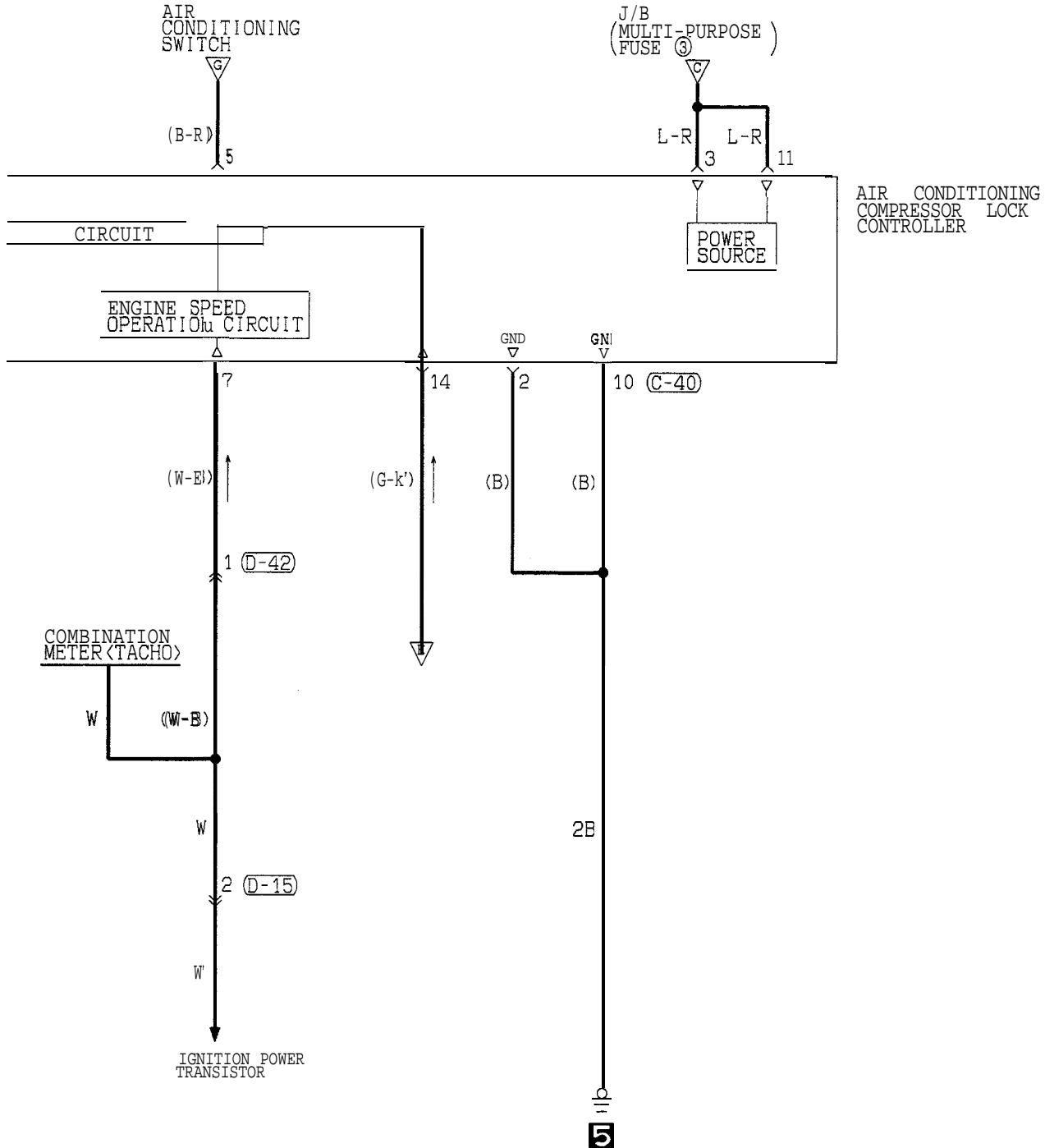

C-40

1	2	3	4	5	6	7	8
9	10	11	12	13	14	15	18

D-15

1	2	3	4
5	6	7	8

D-42

1	2	3	4	5	6	7	8	9	10
11	12	13	14	15	16	17	18	19	20
21	22								

TSB Revision

MANUAL AIR CONDITIONING CIRCUIT (FROM 1996 MODELS) (CONTINUED)

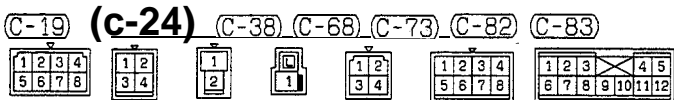
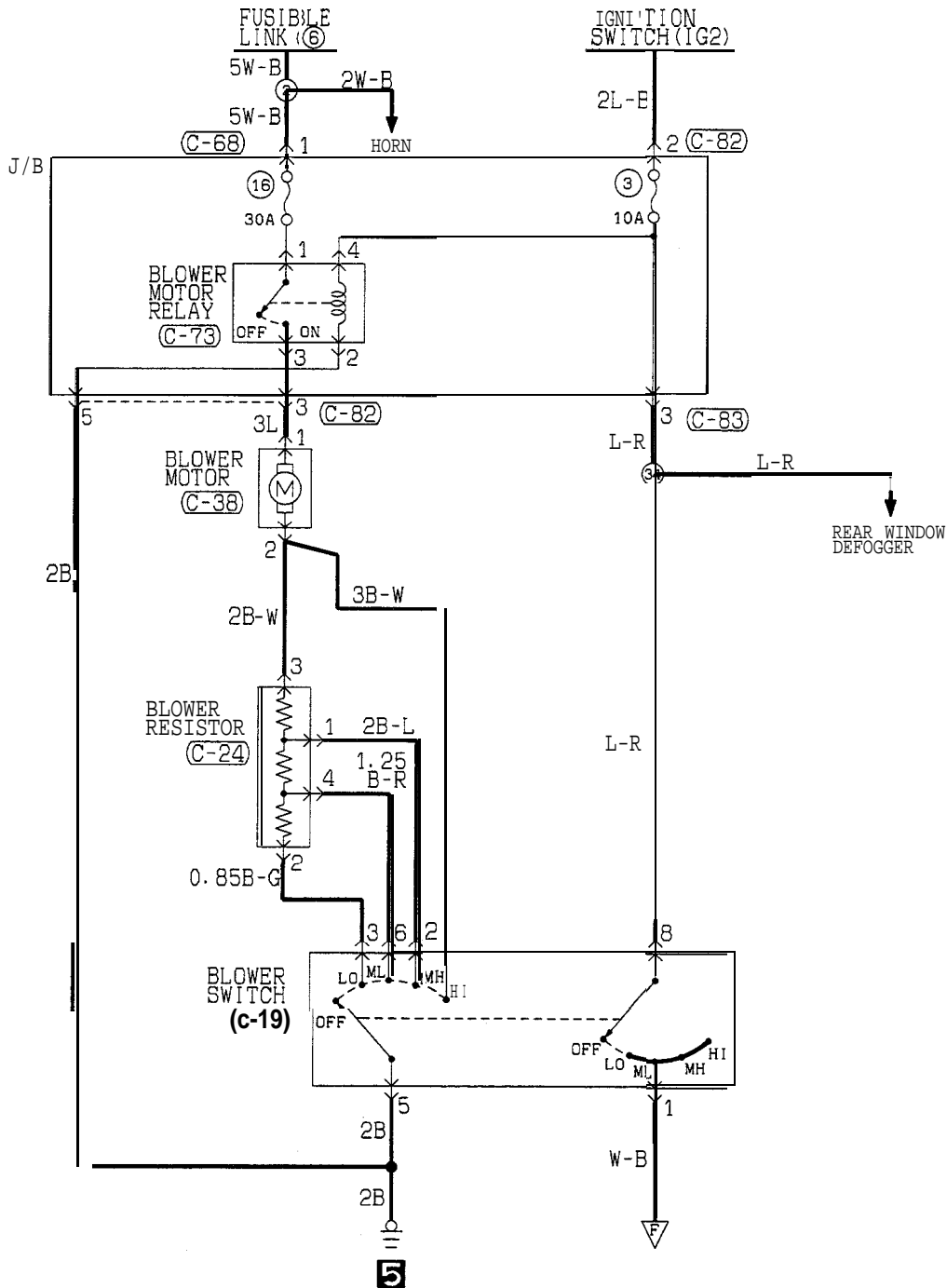

TSB Revision

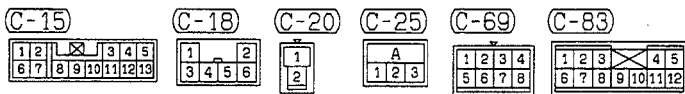
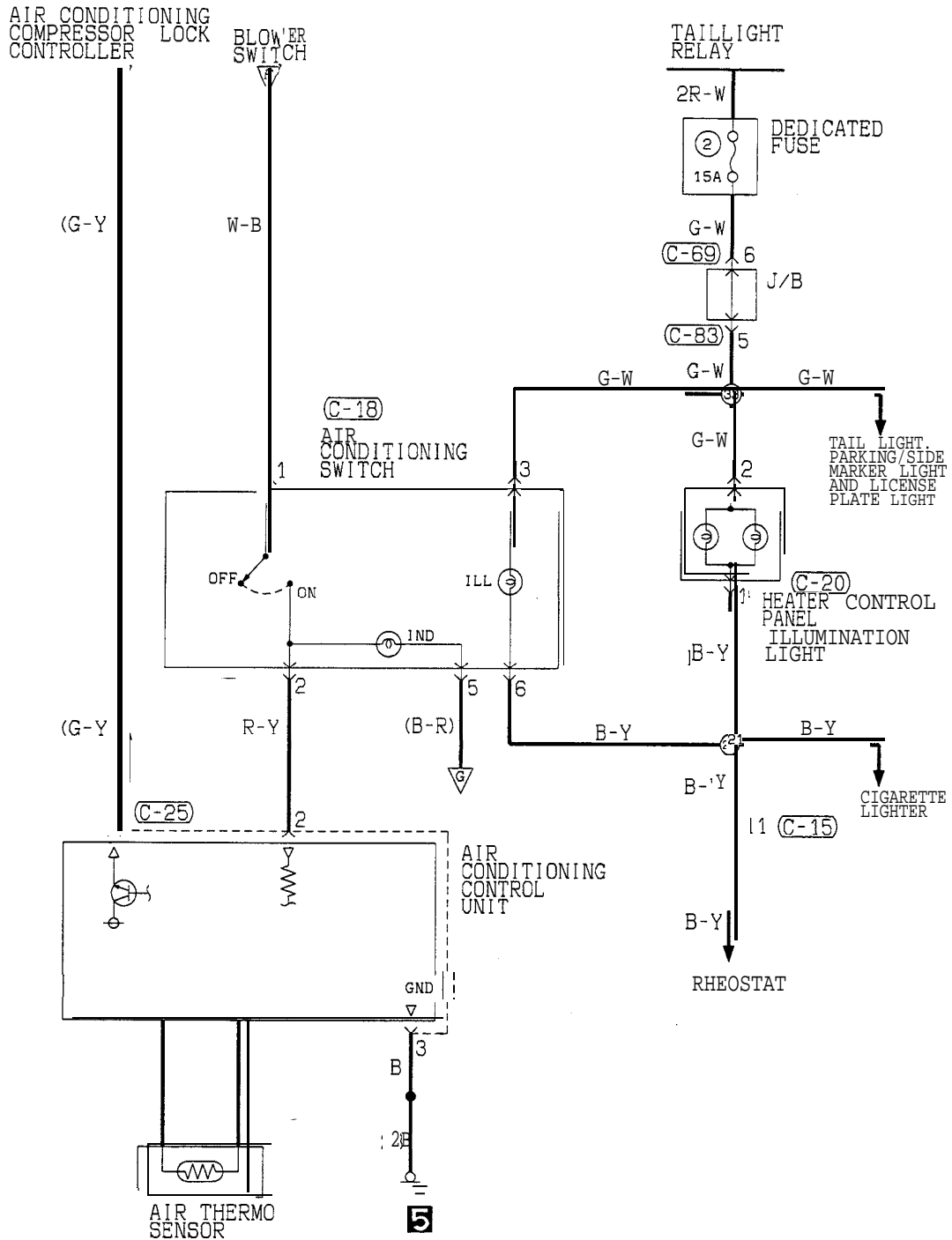

FULL AUTO AIR CONDITIONING CIRCUIT (1992 MODEL)

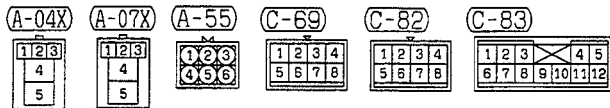
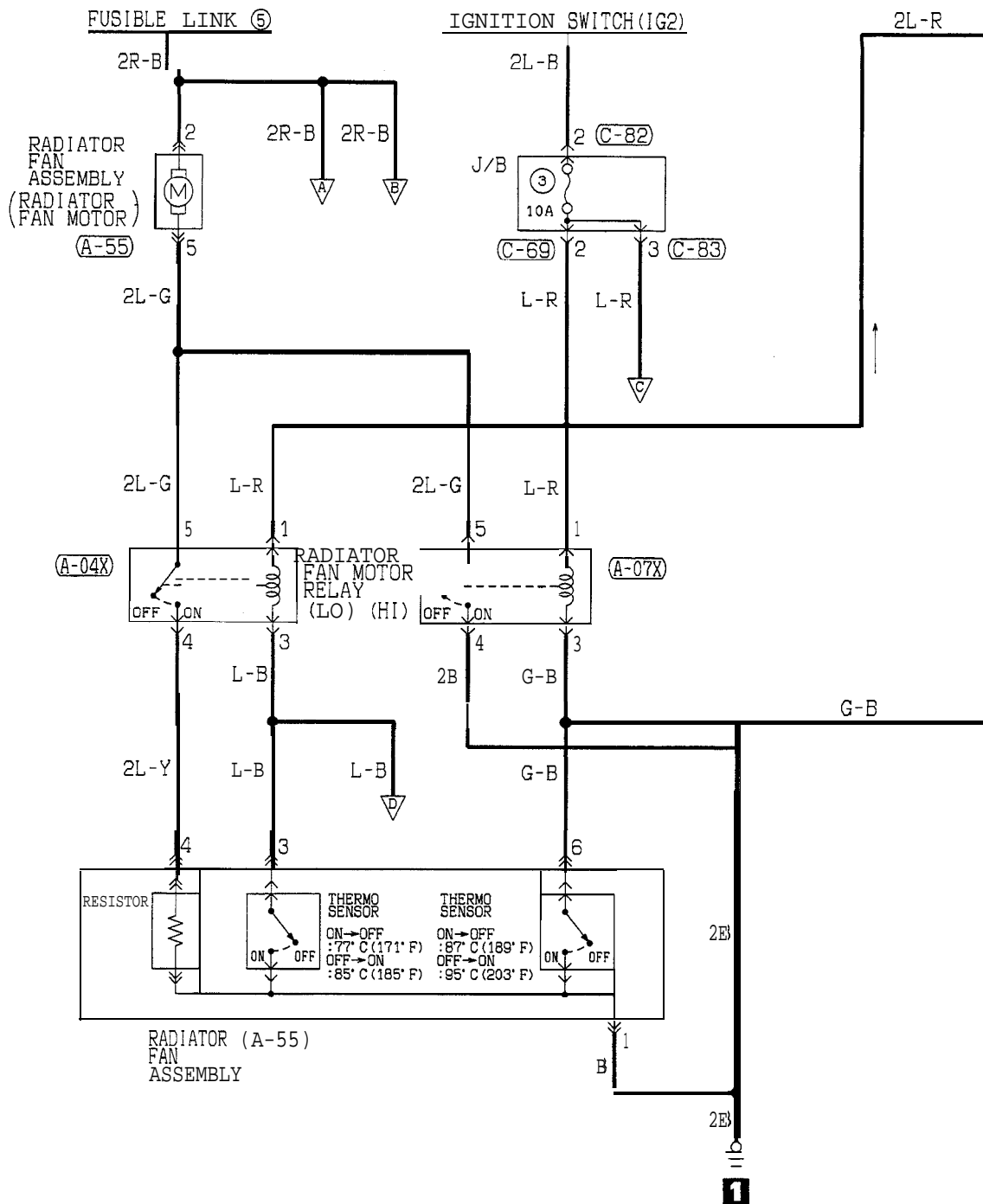

TSB Revision

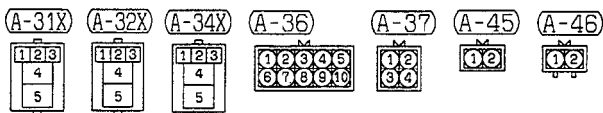
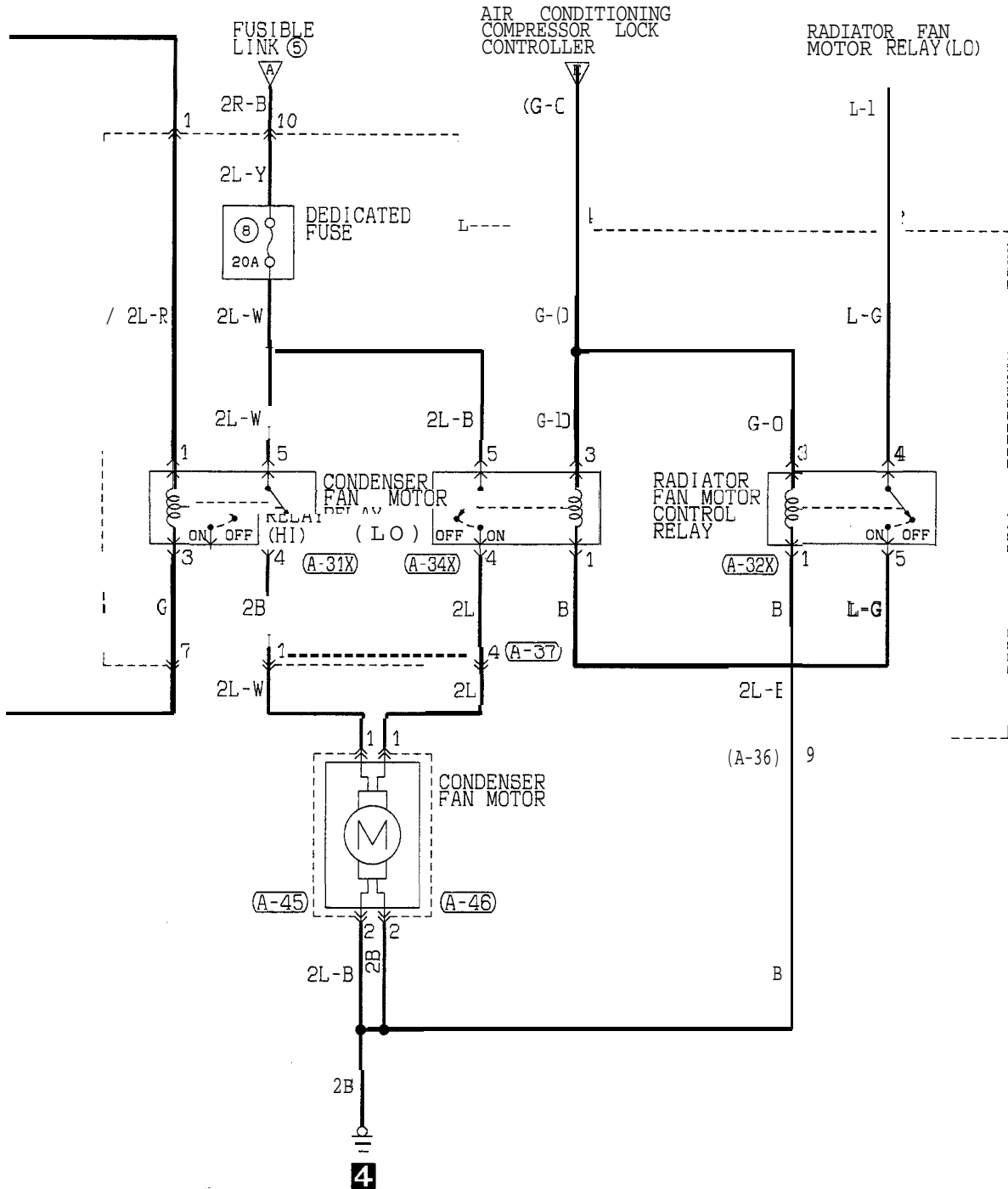

TSB Revision



FULL AUTO AIR CONDITIONING CIRCUIT (1992 MODEL) (CONTINUED)

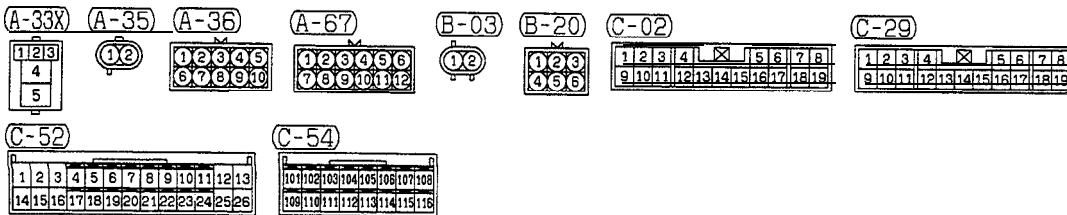
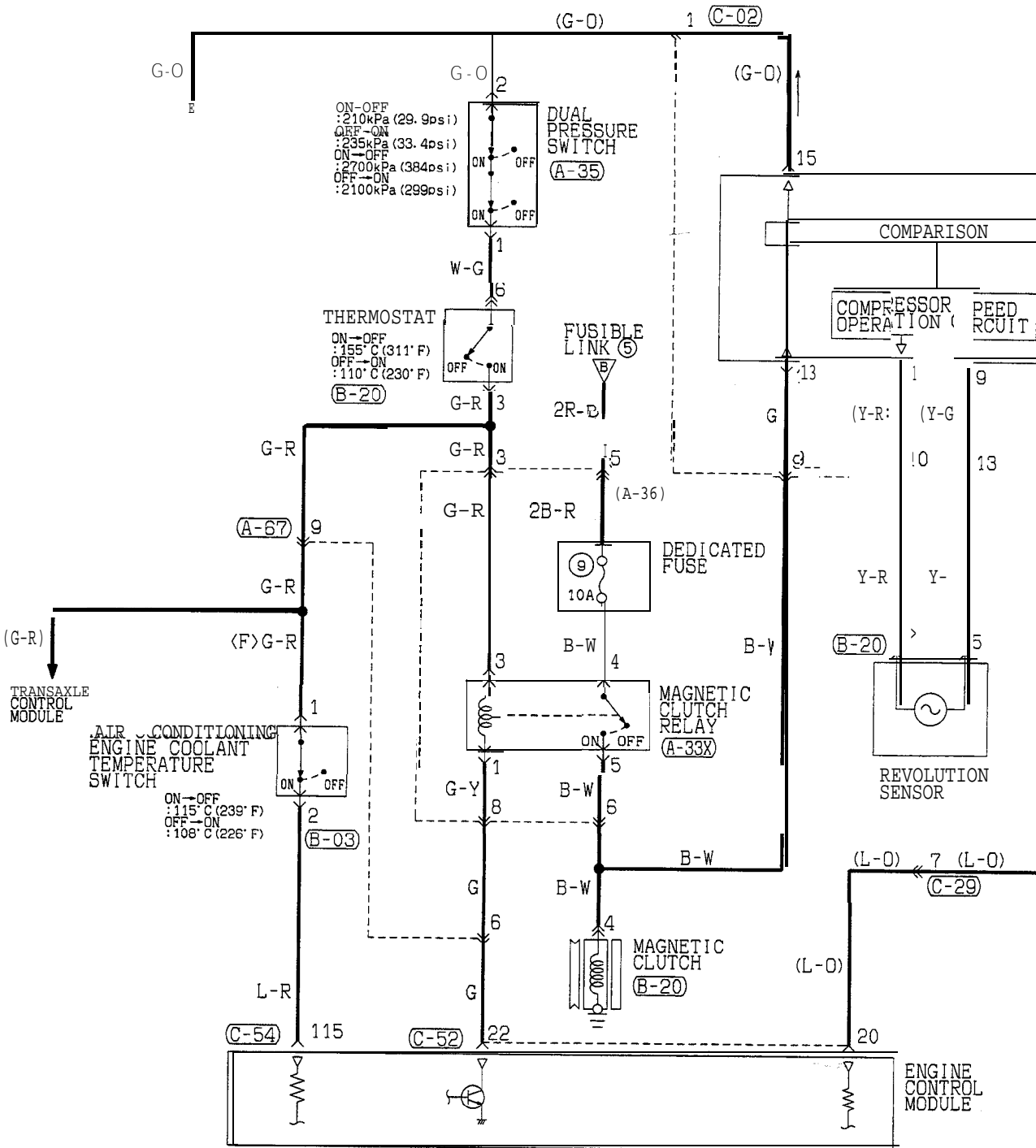

TSB Revision

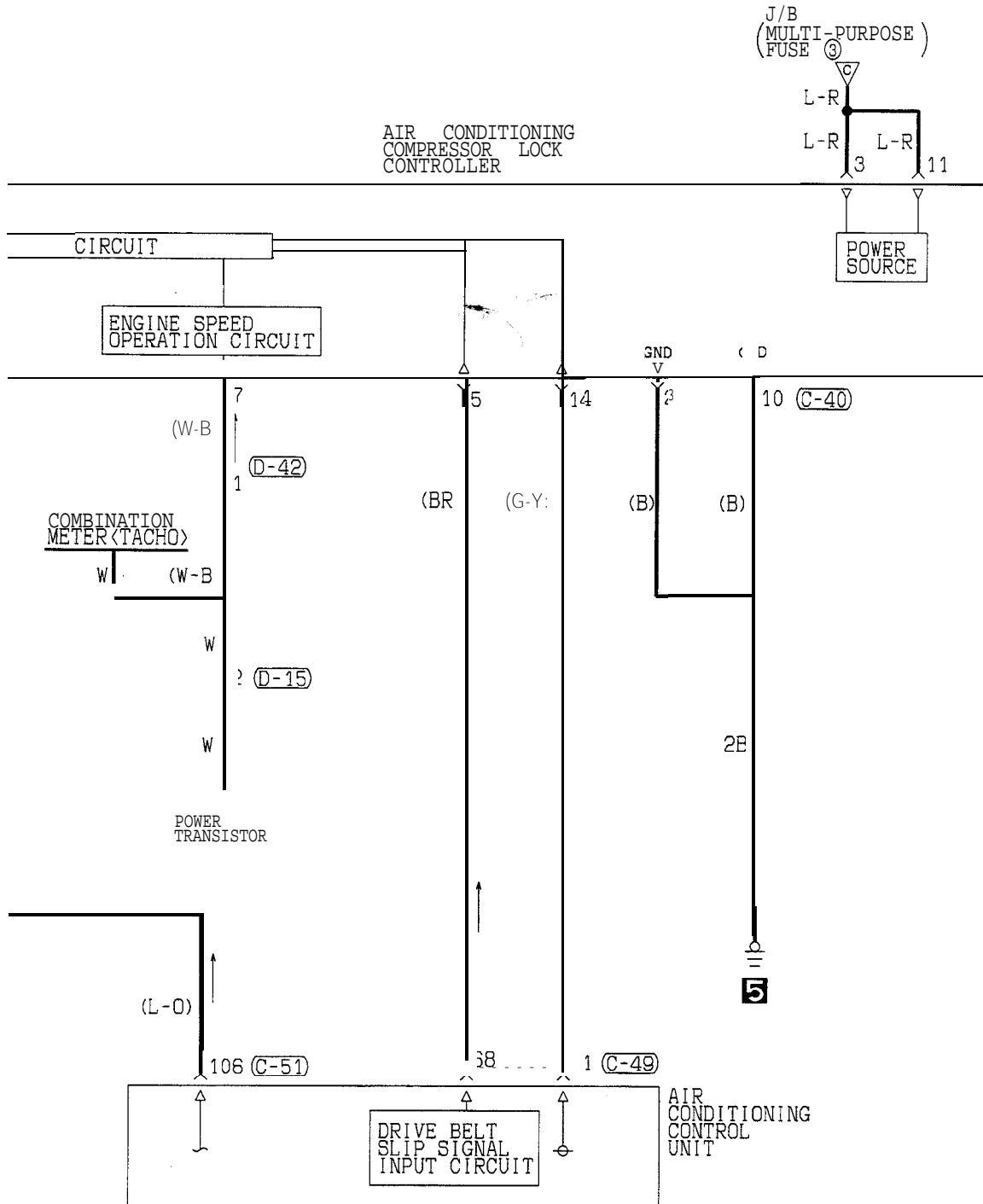

C-40

1	2	3	4	5	6	7	8
9	10	11	12	13	14	15	16

C-49

51	52	53	54	55	56	57	58	59	60
61	62	63	64	65	66	67	68	69	70

C-51

101	102	103	104	105	106	107	108
109	110	111	112	113	114	115	116

D-15

1	2	M	3	4	
5	6	7	8	9	10

D-42

1	2	3	4	5	M	7	8	9	10		
11	12	13	14	15	16	17	18	19	20	21	22

TSB Revision

FULL AUTO AIR CONDITIONING CIRCUIT (1992 MODEL) (CONTINUED)

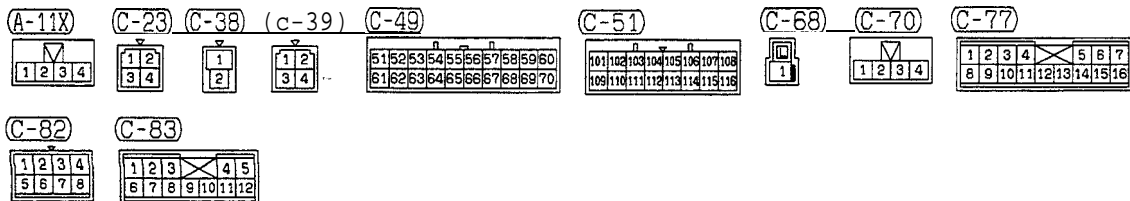
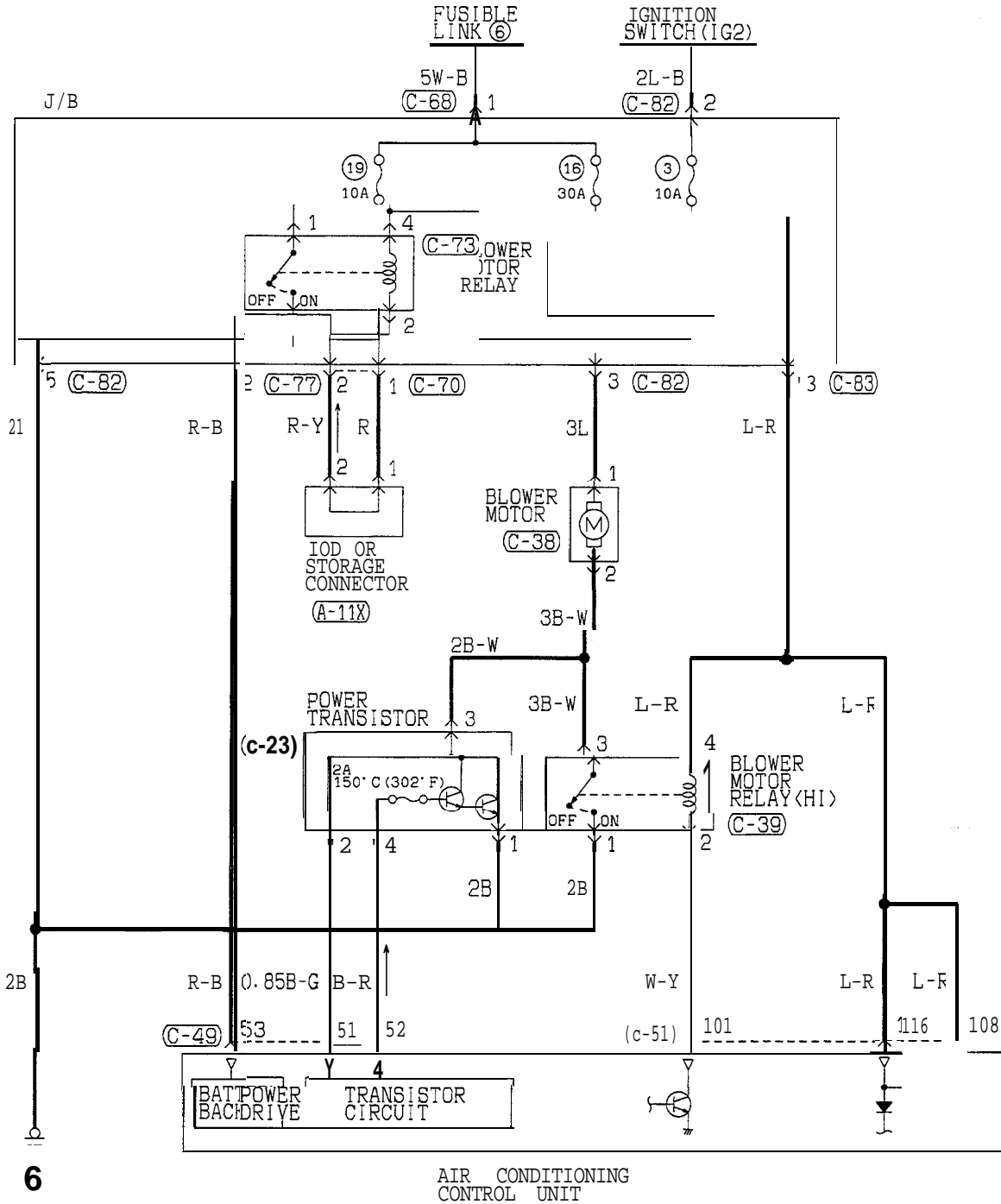

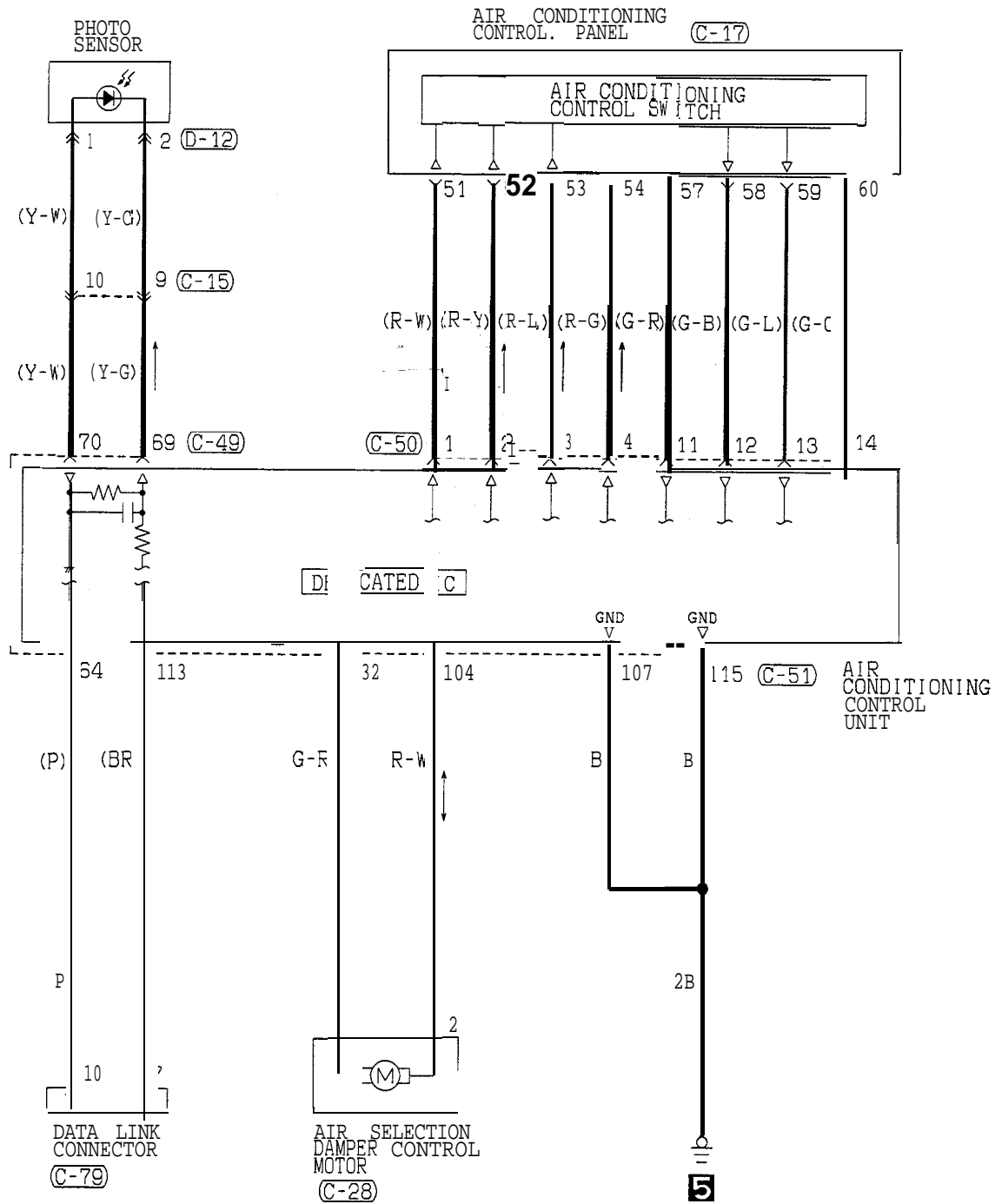

C-15

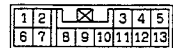

C-17

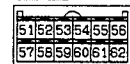

C-28



C-49

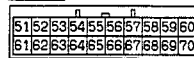

C-50

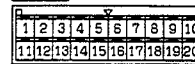

C-51

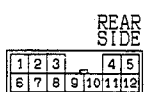
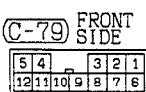
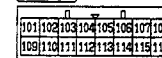

TSB Revision

FULL AUTO AIR CONDITIONING CIRCUIT (1992 MODEL) (CONTINUED)

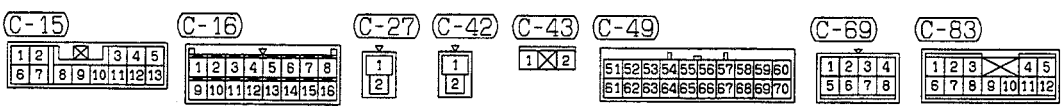
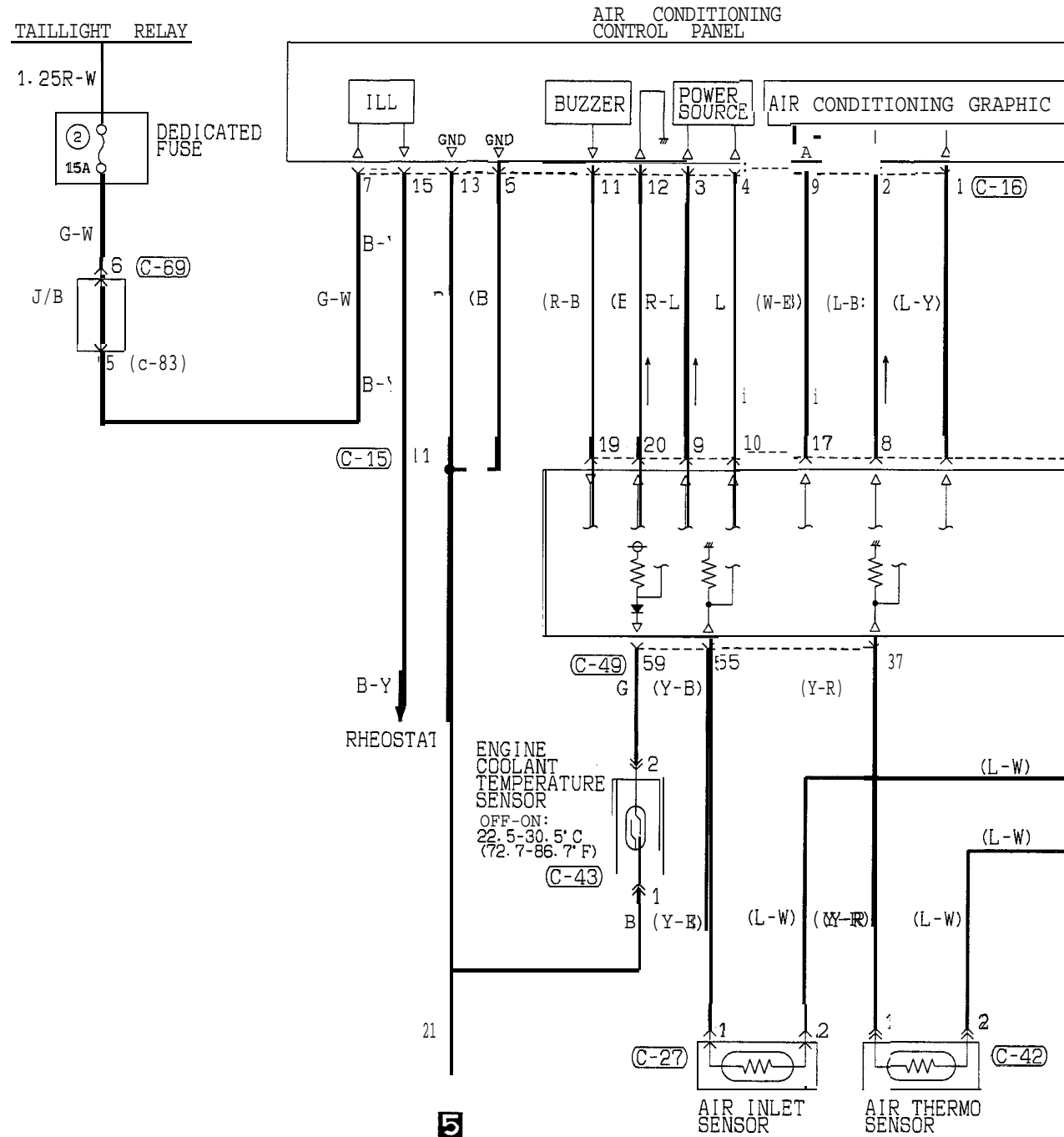

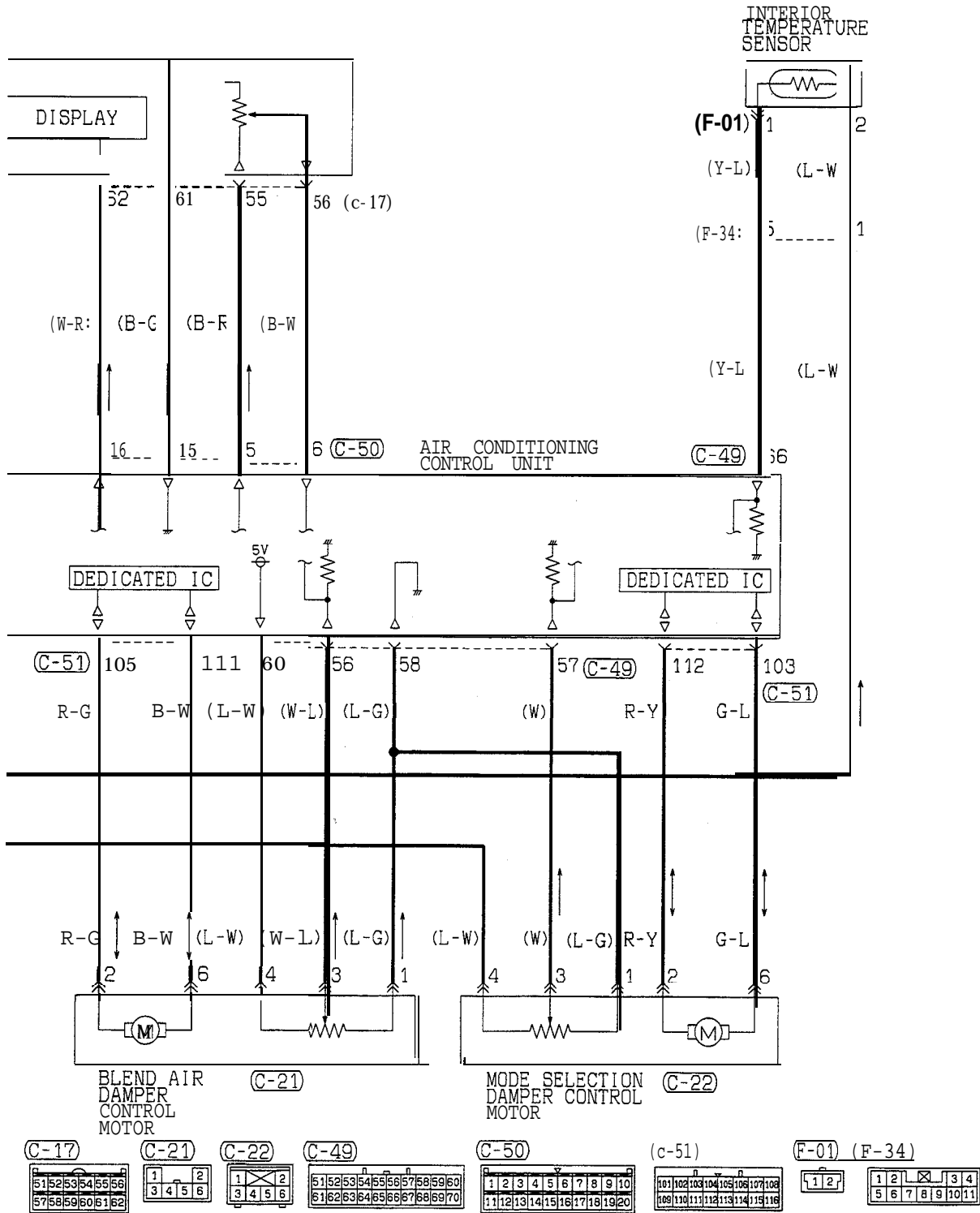

# FULL AUTO AIR CONDITIONING CIRCUIT (1993 MODELS)

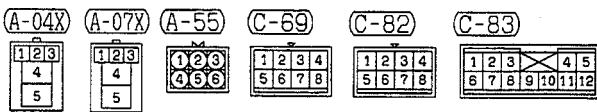
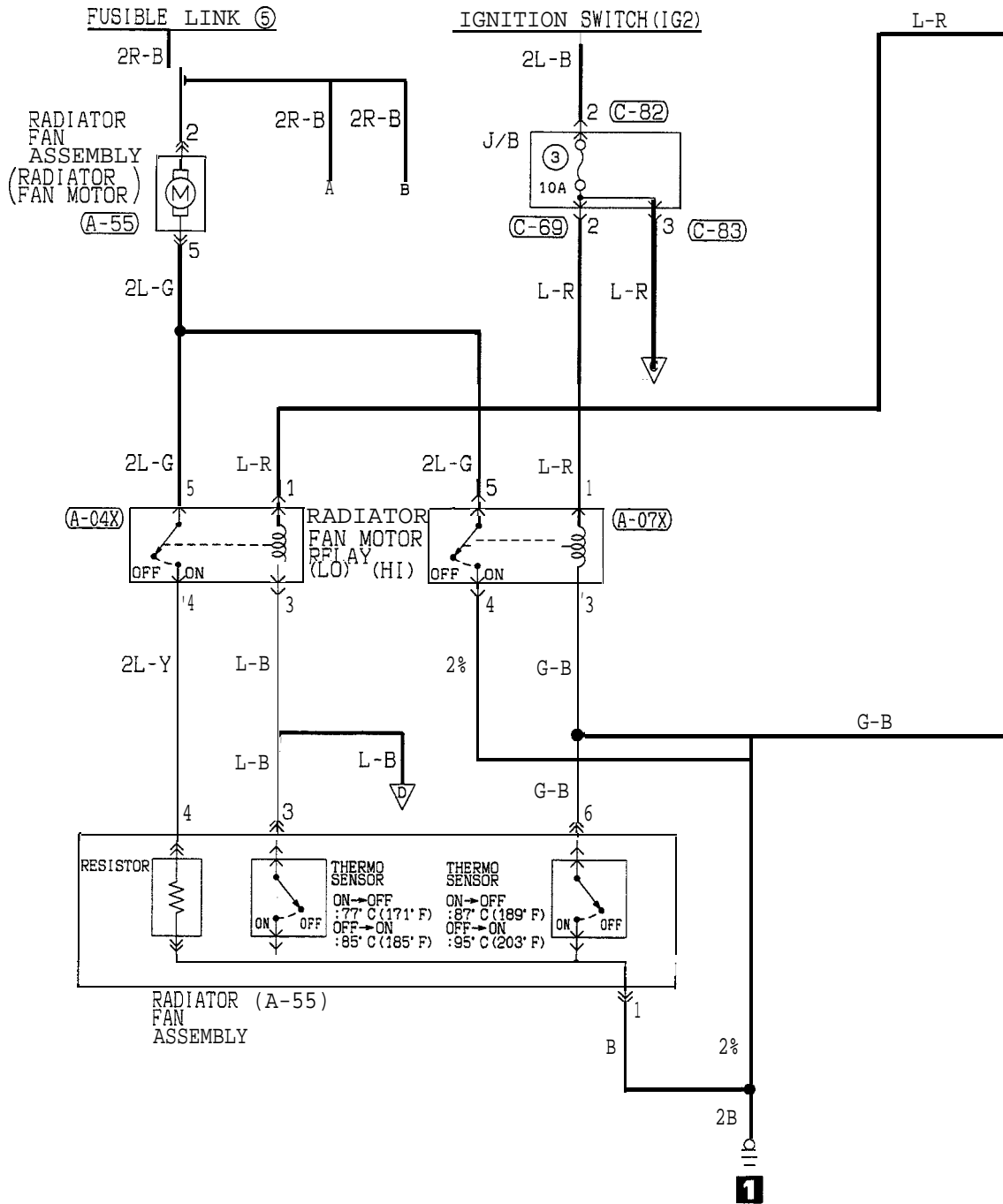

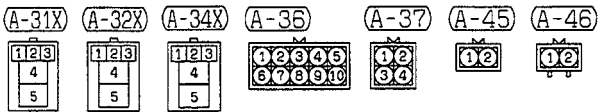
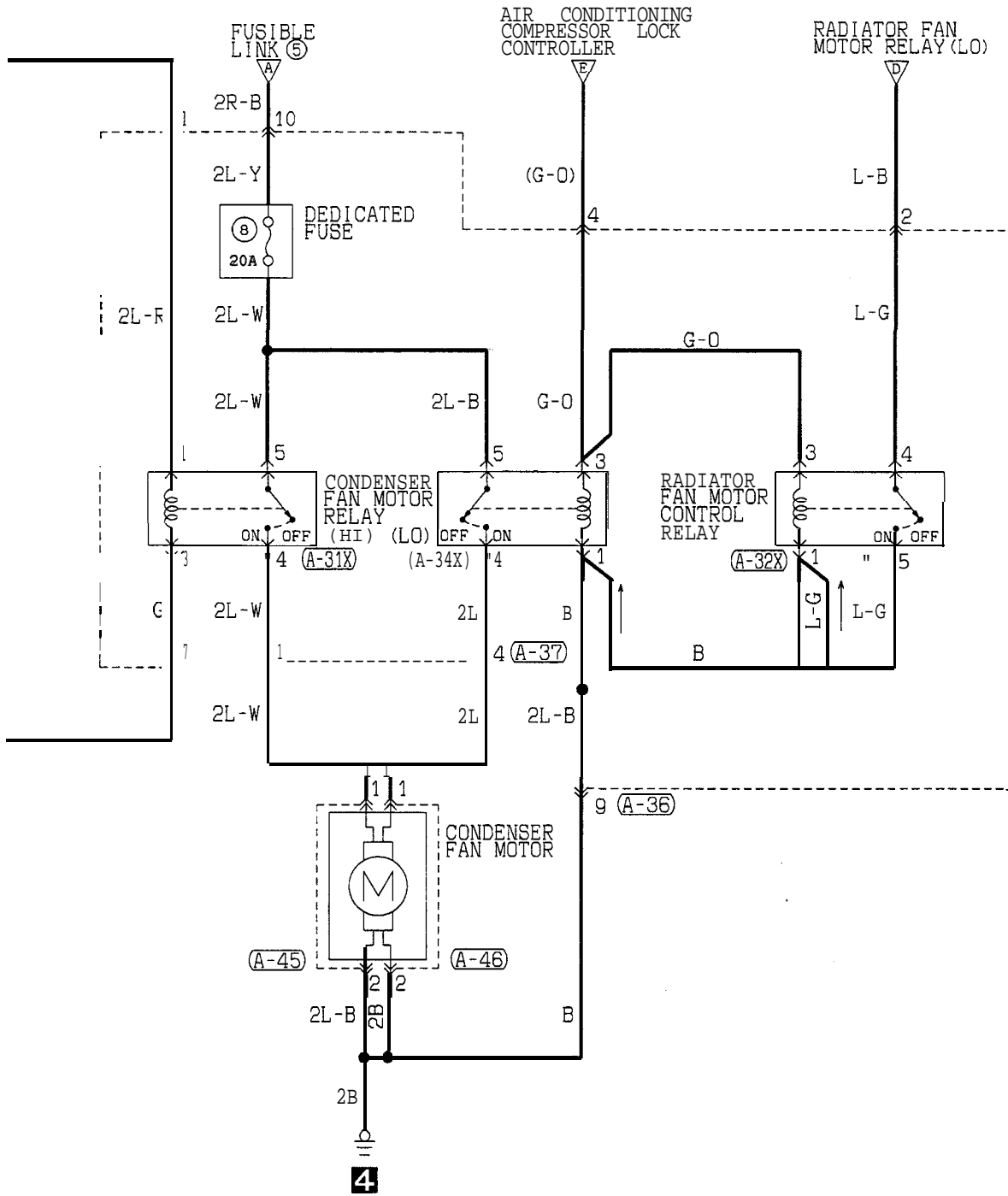

TSB Revision



FULL AUTO AIR CONDITIONING CIRCUIT (1993 MODELS) (CONTINUED)

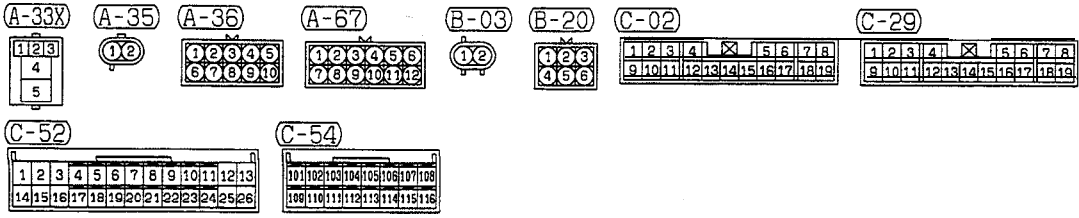
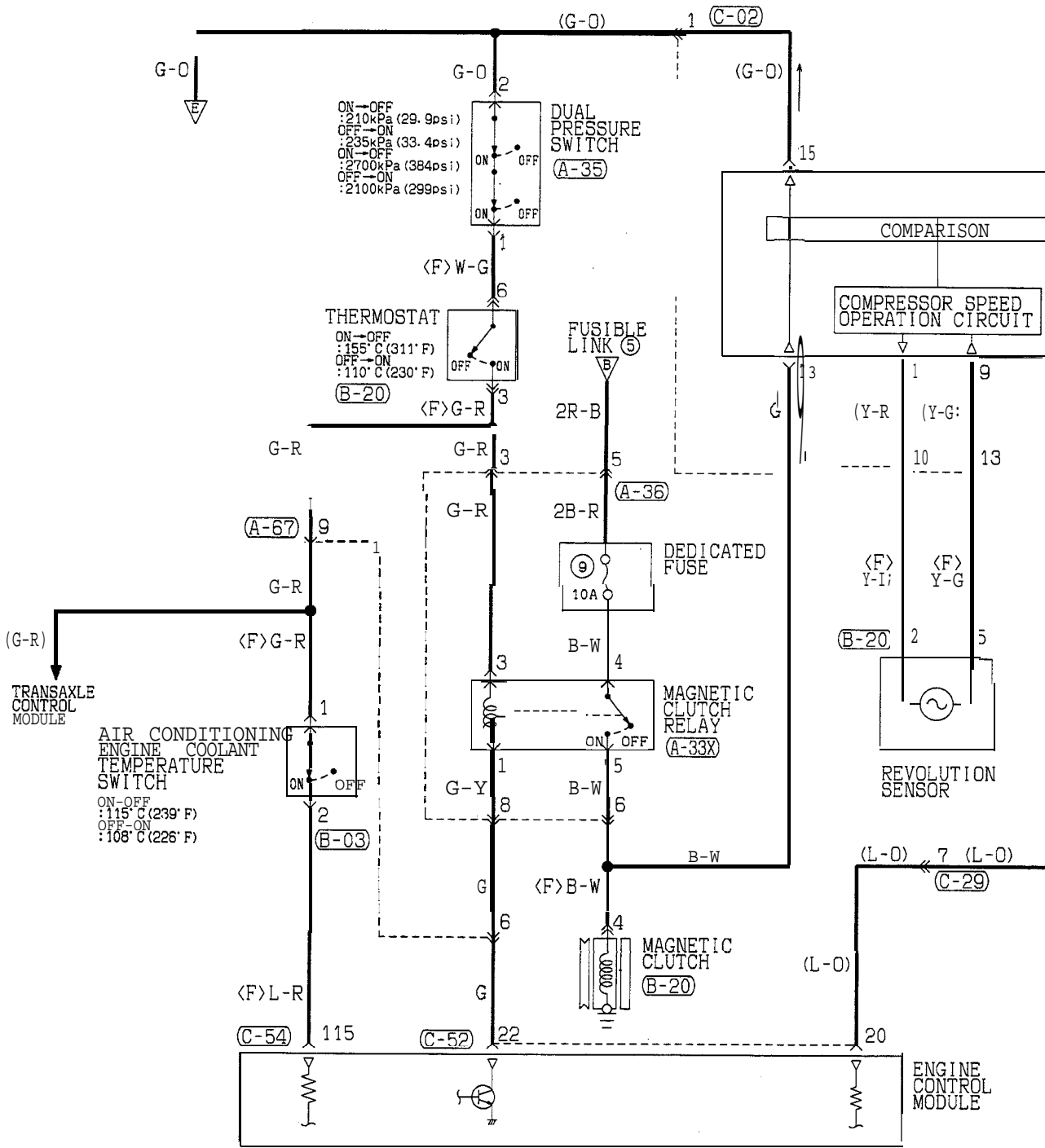

TSB Revision

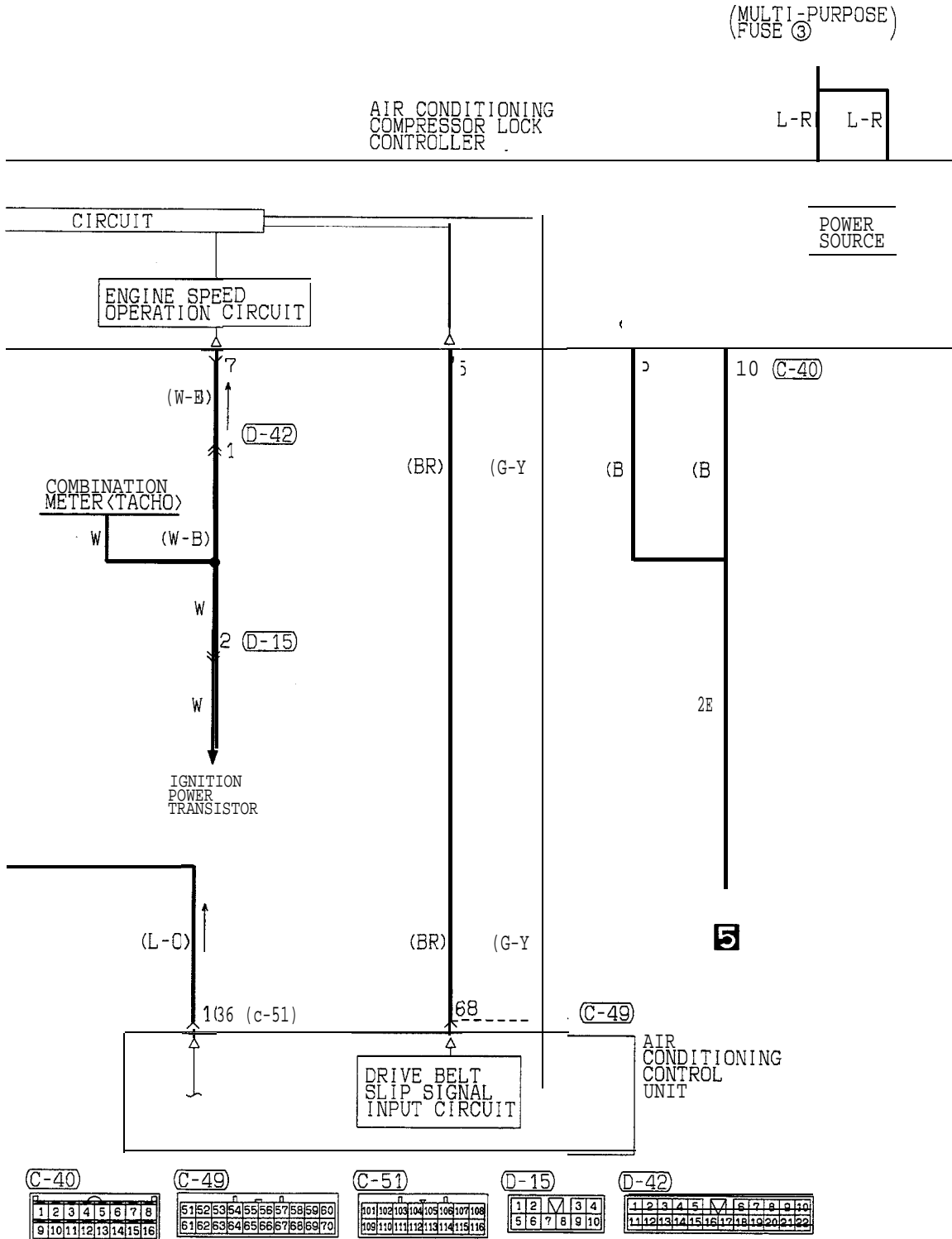

FULL AUTO AIR CONDITIONING CIRCUIT (1993 MODELS) (CONTINUED)

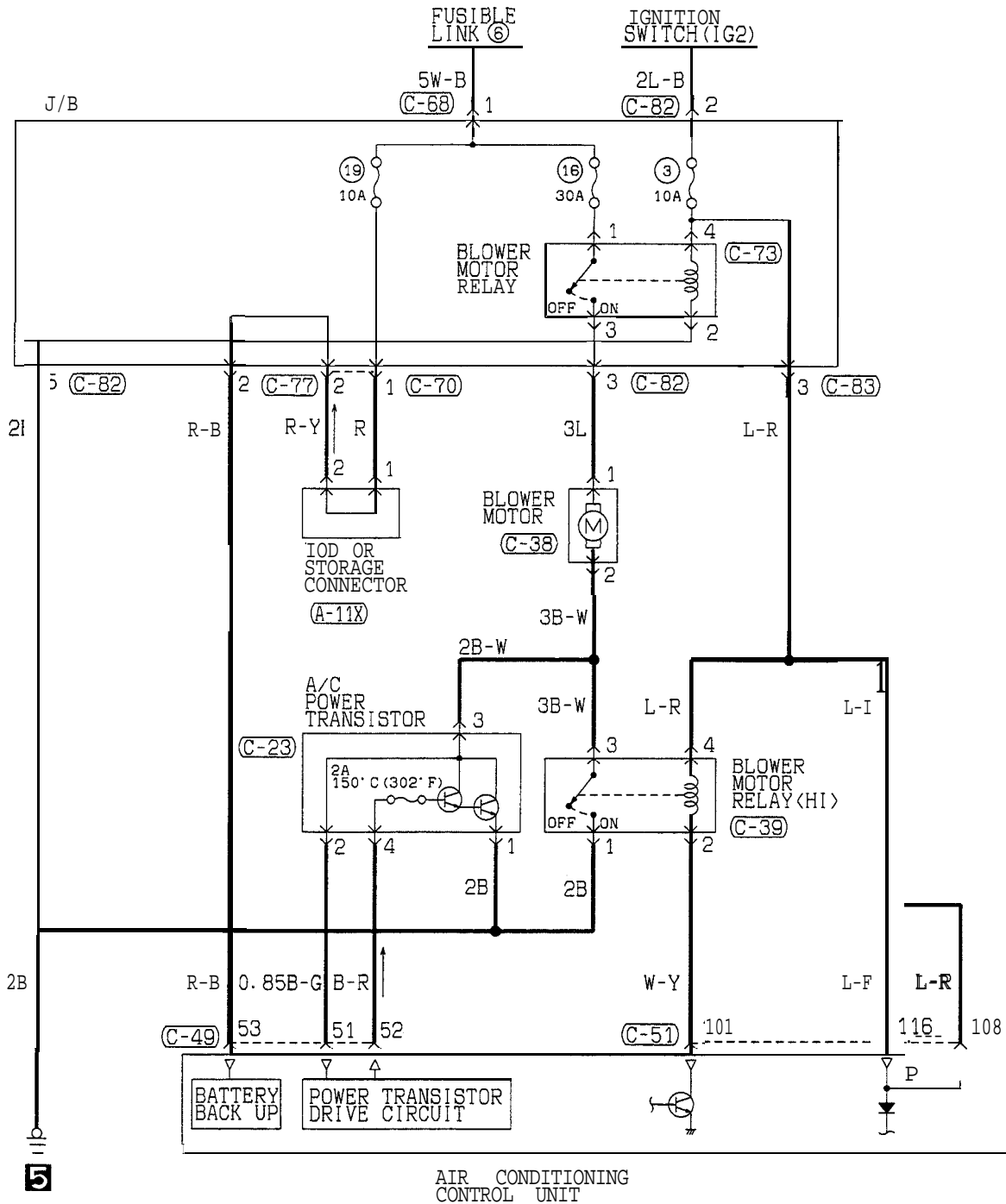

<b>A-11X</b> M 1 2 3 4	<b>C-23</b> 1 2 3 4	<b>C-38</b> 1 2	<b>C-39</b> 1 2 3 4	<b>C-49</b> 51 52 53 54 55 56 57 58 59 60 61 62 63 64 65 66 67 68 69 70	<b>C-51</b> 101 102 103 104 105 106 107 108 109 110 111 112 113 114 115 116	<b>C-68</b> 1	<b>C-70</b> M 1 2 3 4	<b>C-77</b> 1 2 3 4 X 5 6 7 8 9 10 11 12 13 14 15 16
<b>C-82</b> 1 2 3 4 5 6 7 8	<b>C-83</b> 1 2 3 X 4 5 6 7 8 9 10 11 12							

TSB Revision

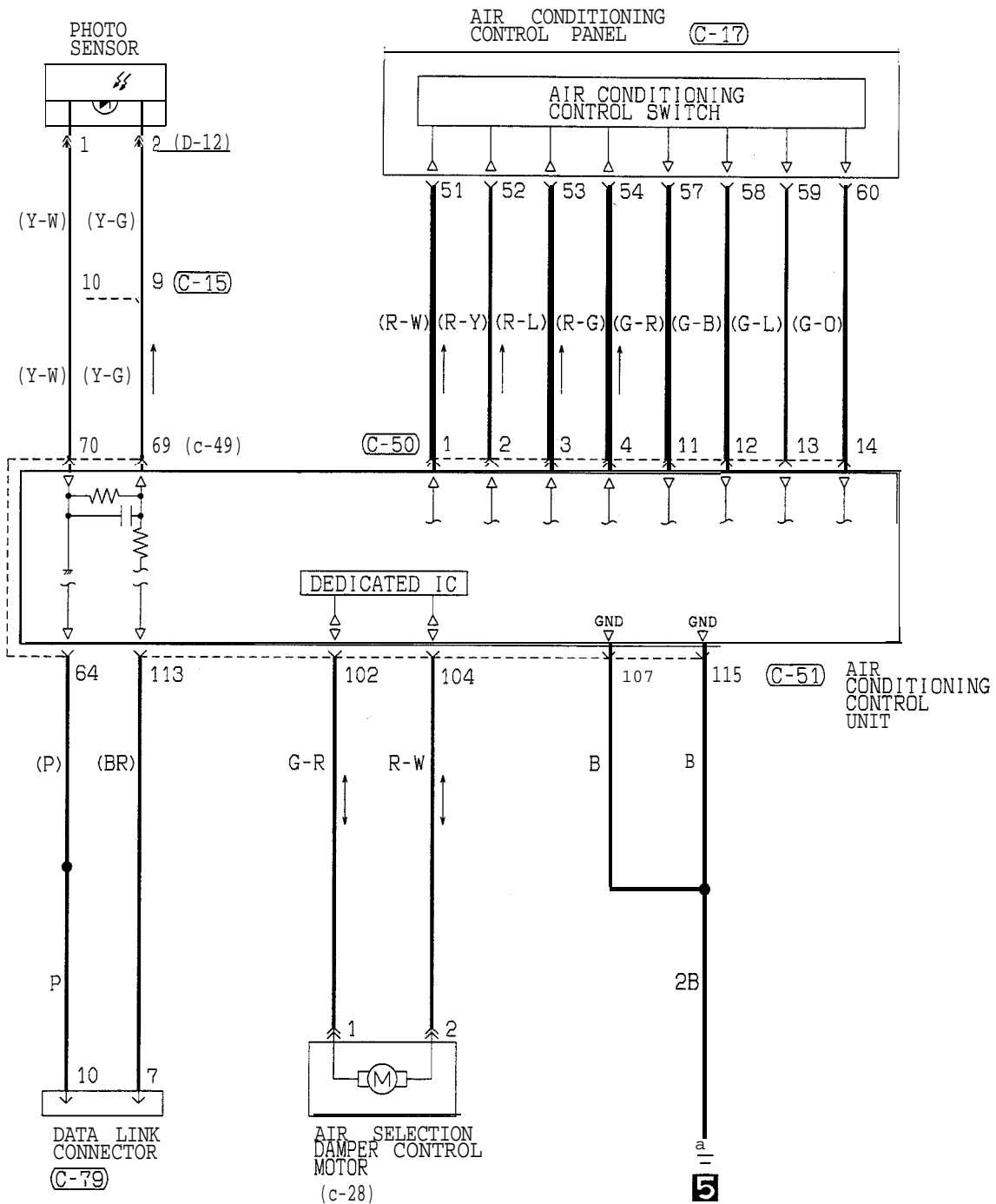

C-15

1	2	3	4	5
6	7	8	9	10
11	12	13		

C-17

51	52	53	54	55	56
57	58	59	60	61	62

C-28

1	2
---	---

C-49

51	52	53	54	55	56	57	58	59	60
61	62	63	64	65	66	67	68	69	70

C-50

1	2	3	4	5	6	7	8	9	10
11	12	13	14	15	16	17	18	19	20

C-51

101	102	103	104	105	106	107	108
109	110	111	112	113	114	115	116

C-79 FRONT SIDE

5	4	3	2	1		
12	11	10	9	8	7	6

REAR SIDE

1	2	3	4	5		
6	7	8	9	10	11	12

D-12

1	2
---	---

TSB Revision

FULL AUTO AIR CONDITIONING CIRCUIT (1993 MODELS) (CONTINUED)

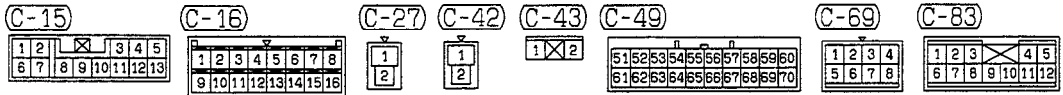
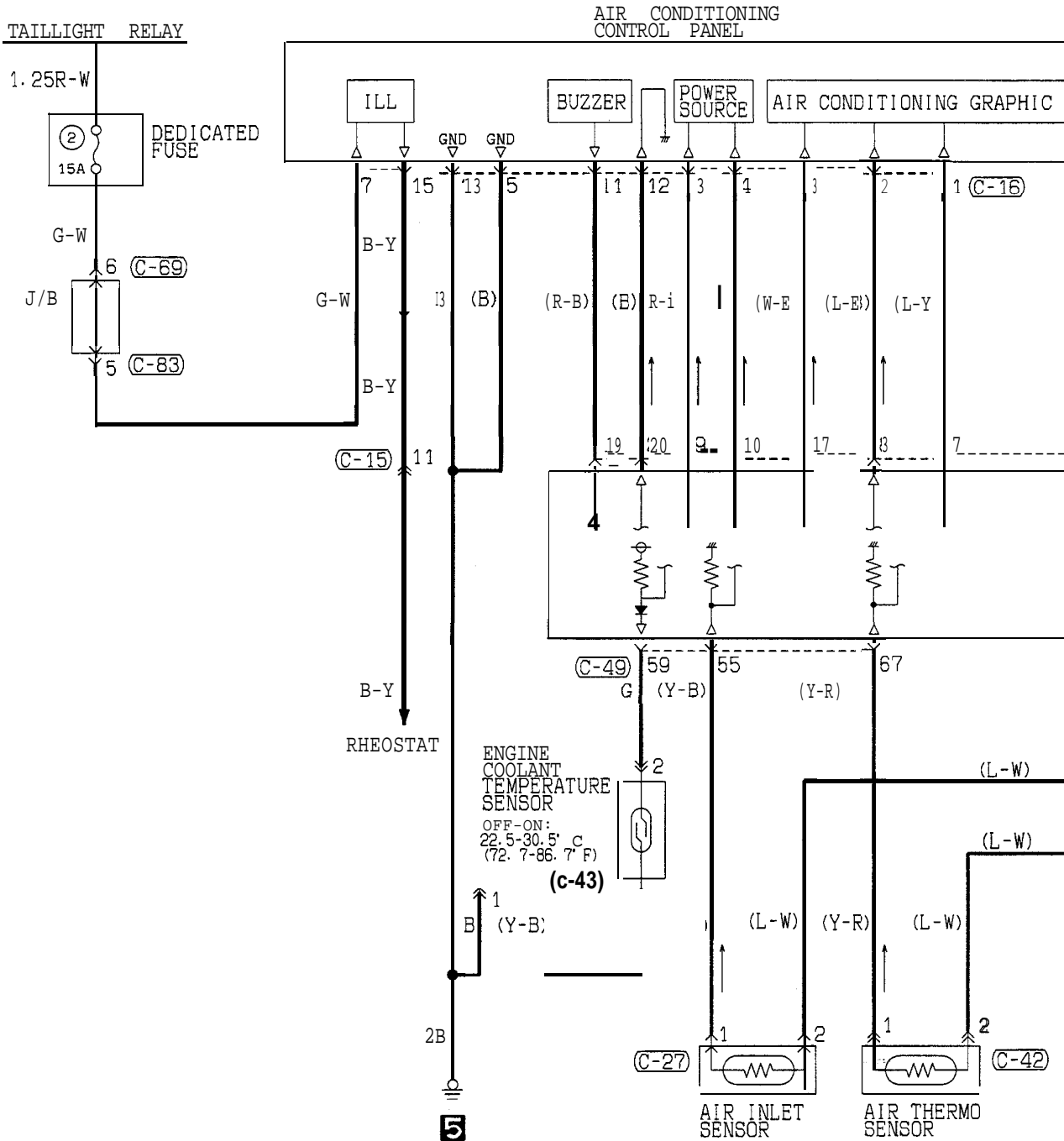

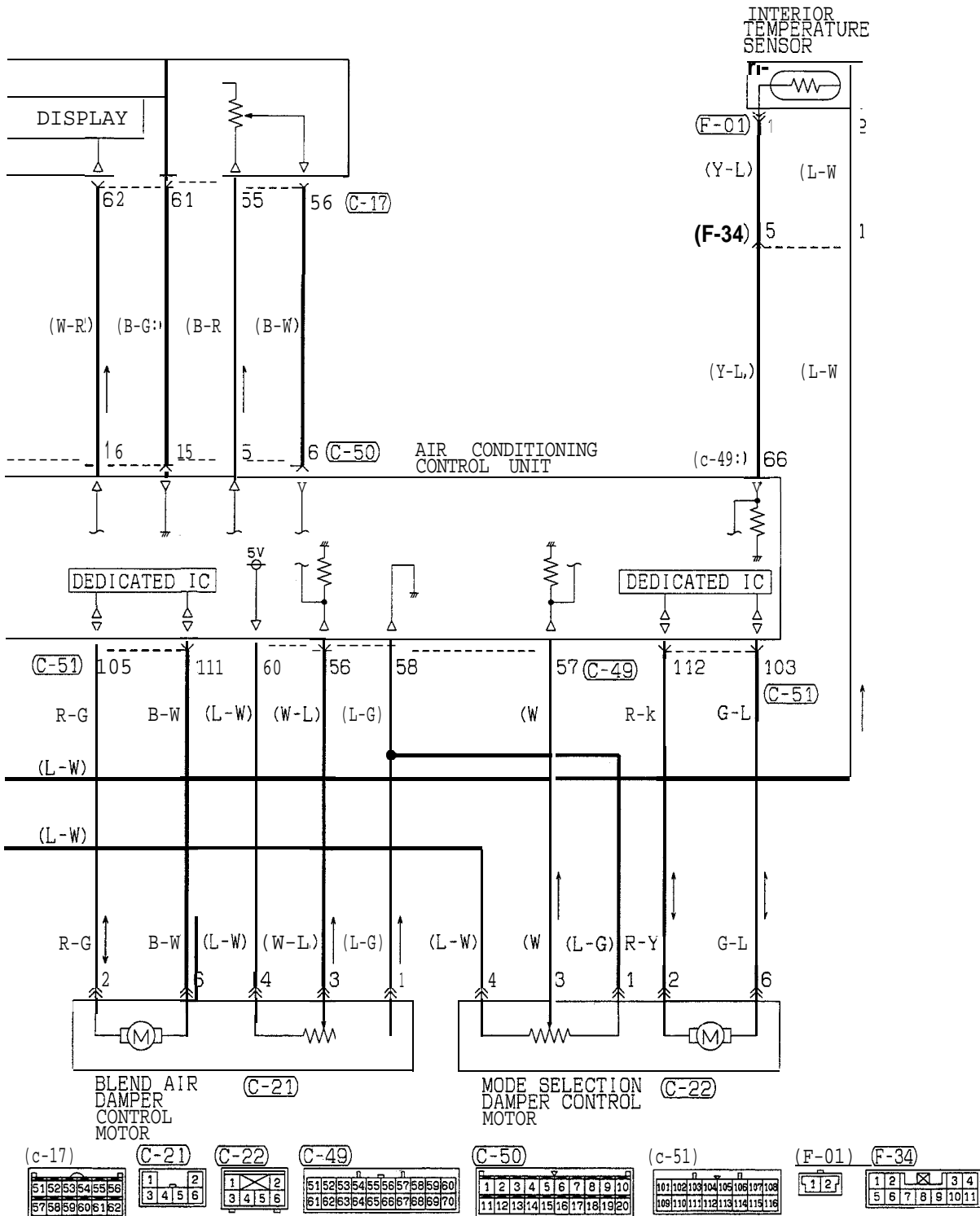

# FULL AUTO AIR CONDITIONING CIRCUIT (1994, 1995 MODELS)

<NON TURBO> (FEDERAL)

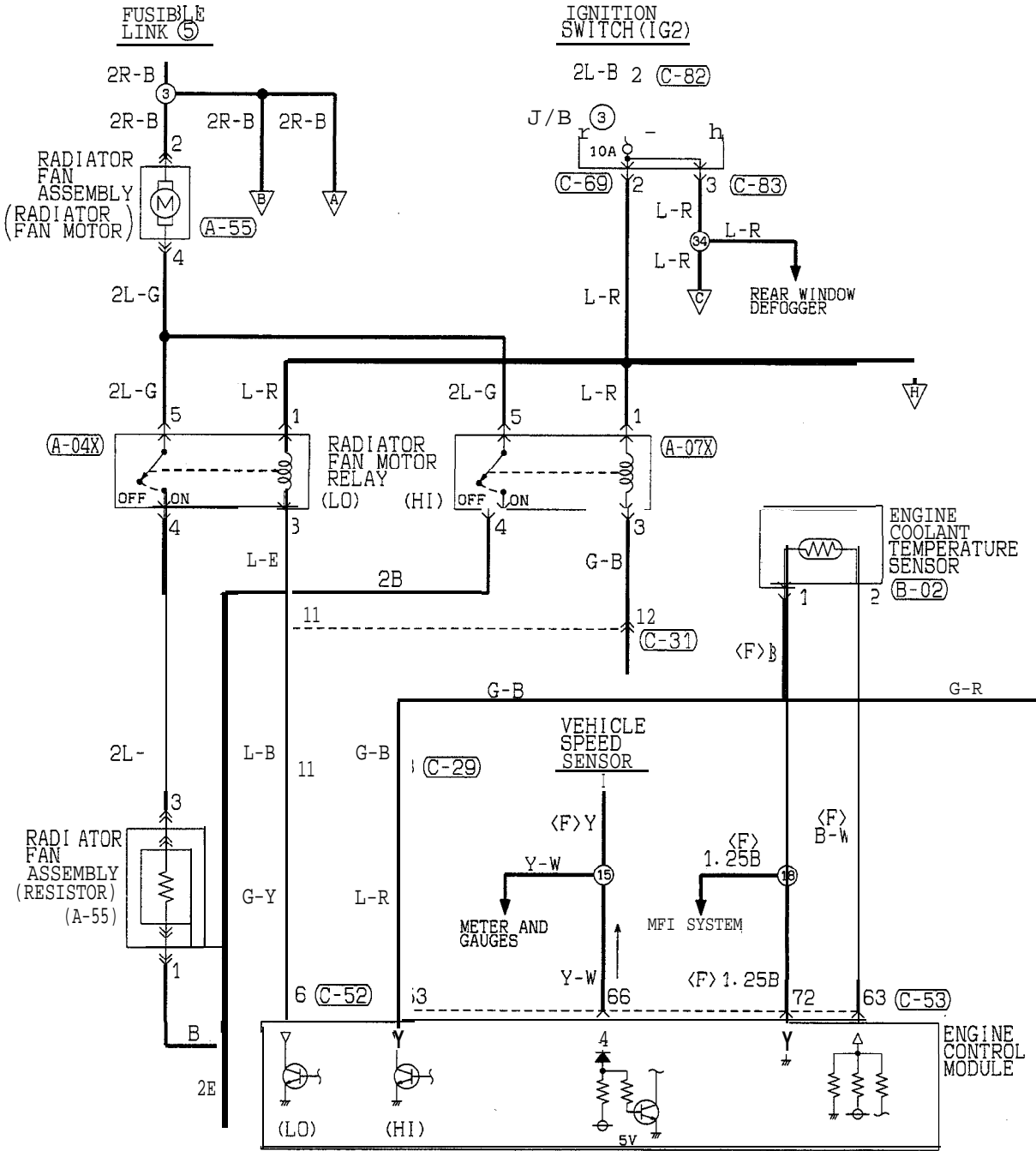

1

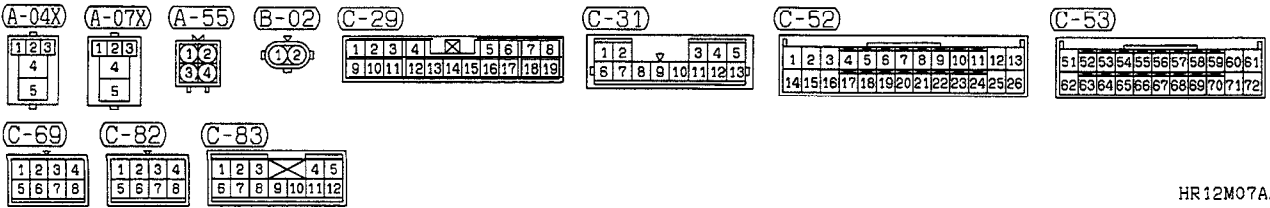

TSB Revision

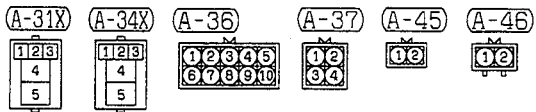
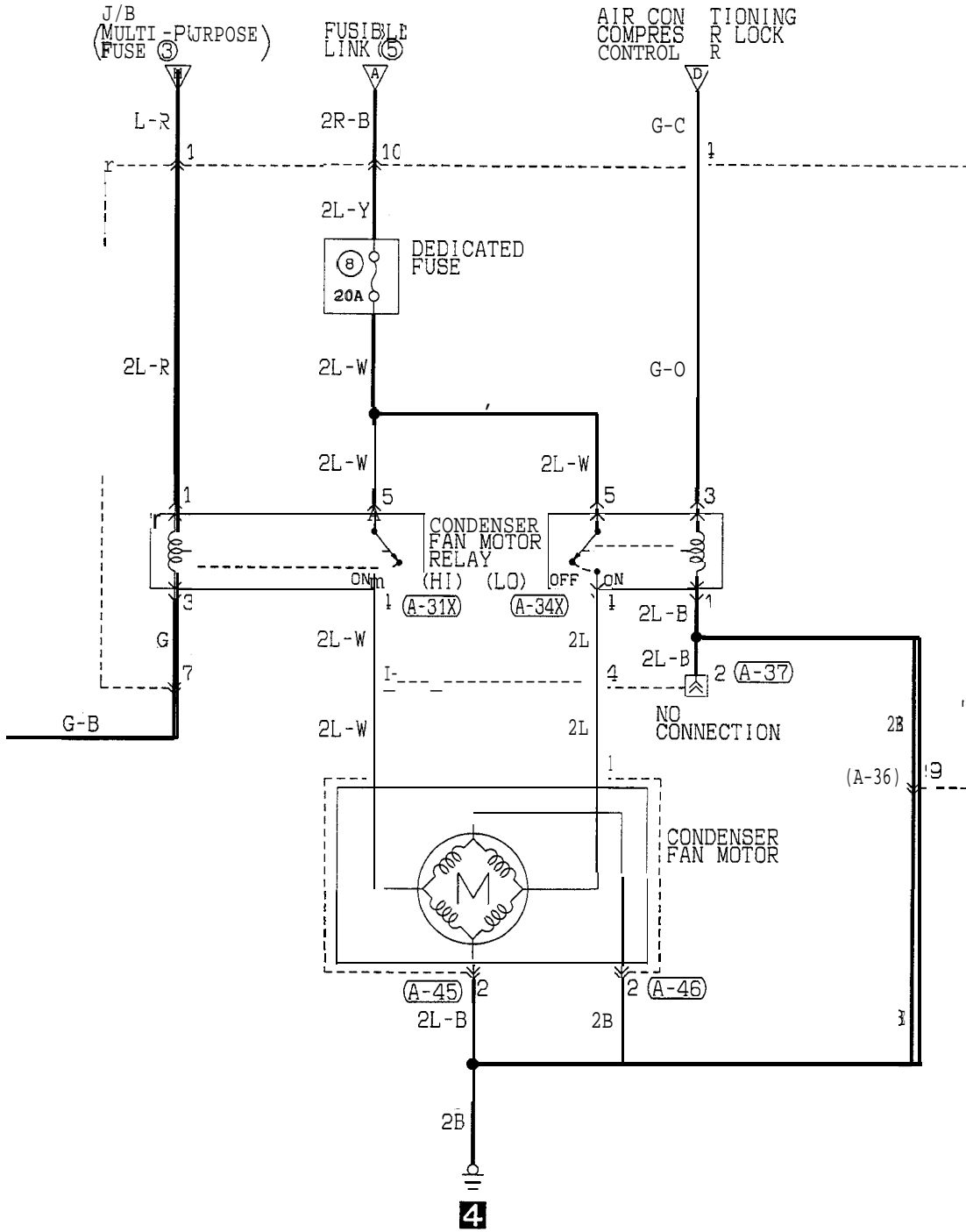



FULL AUTO AIR CONDITIONING CIRCUIT (1994, 1995 MODELS)  
 <NON TURBO> (FEDERAL) (CONTINUED)

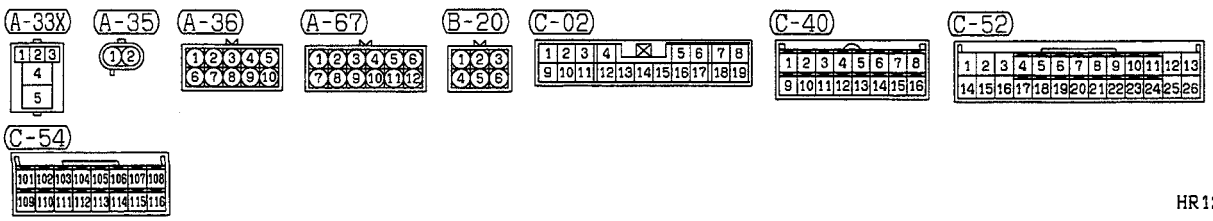
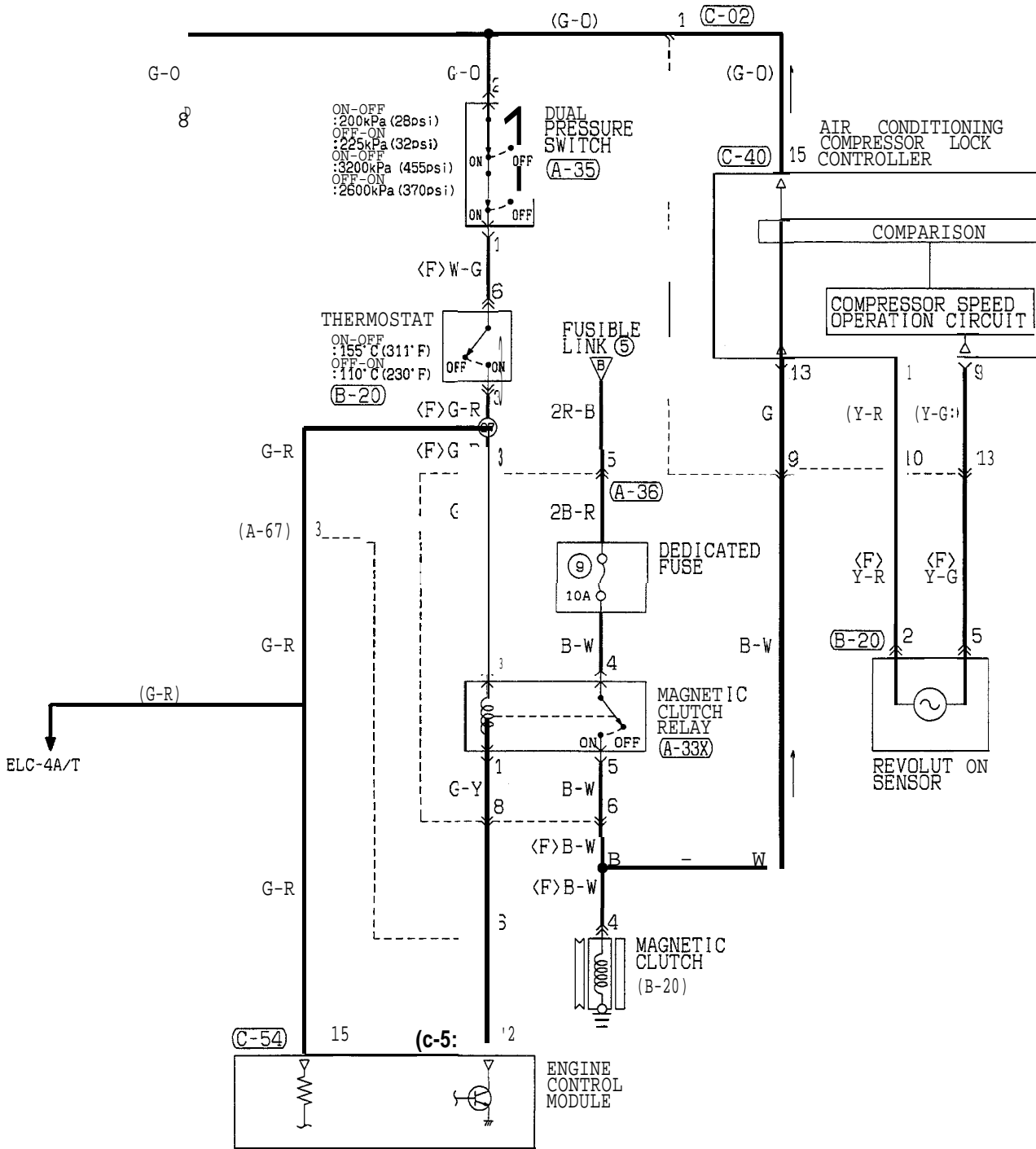

TSB Revision

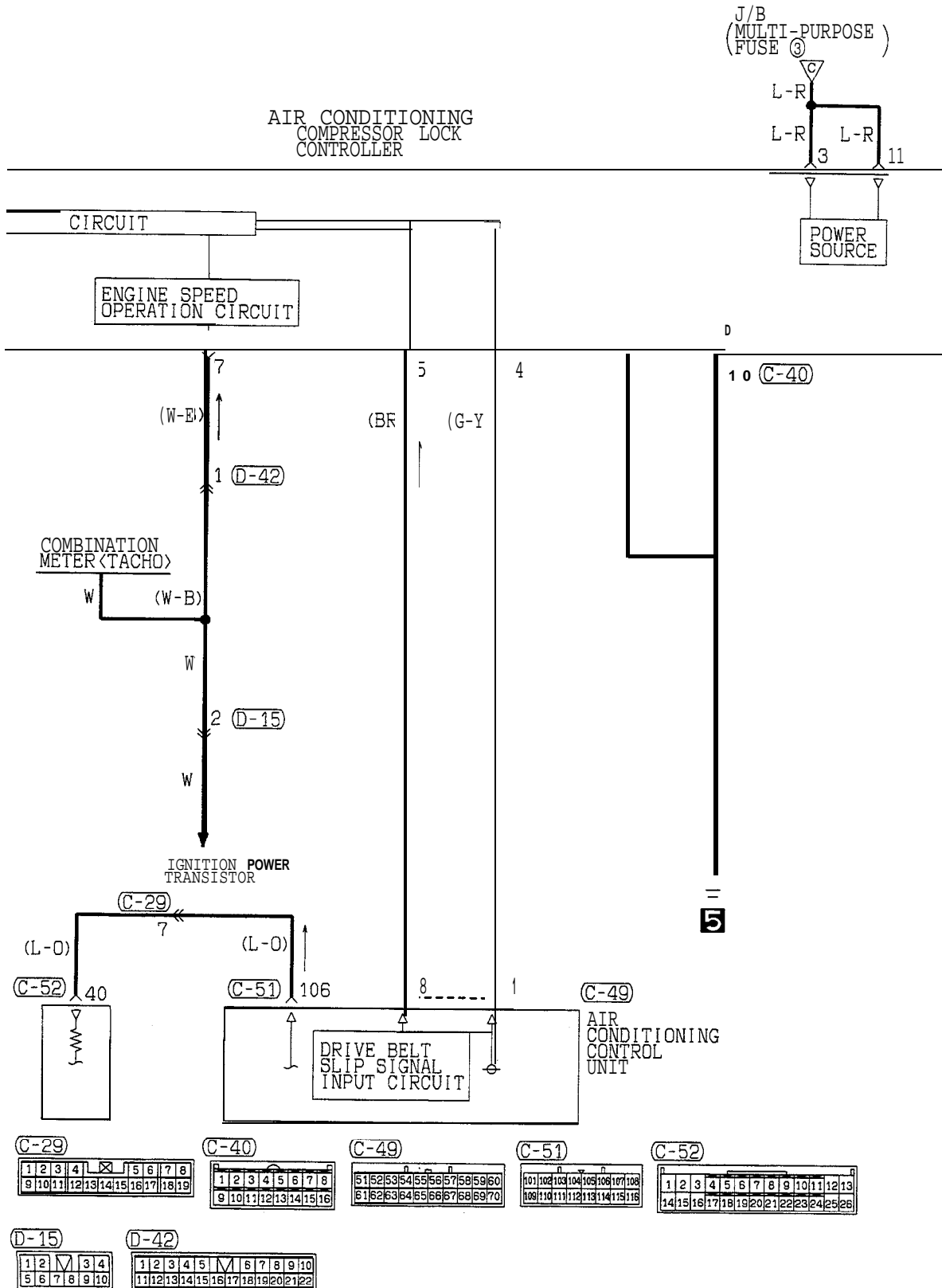

TSB Revision

FULL AUTO AIR CONDITIONING CIRCUIT (1994, 1995 MODELS) <NON TURBO> (FEDERAL) (CONTINUED)

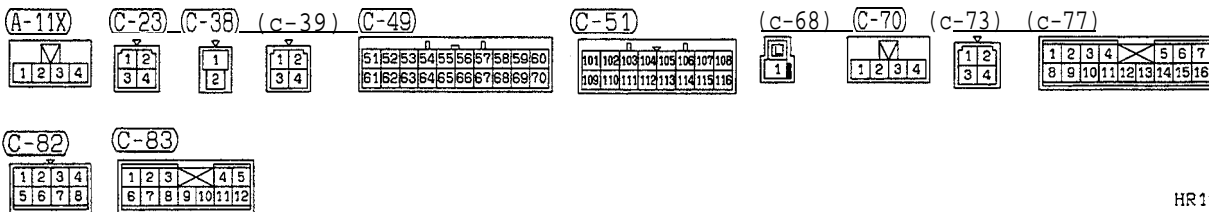
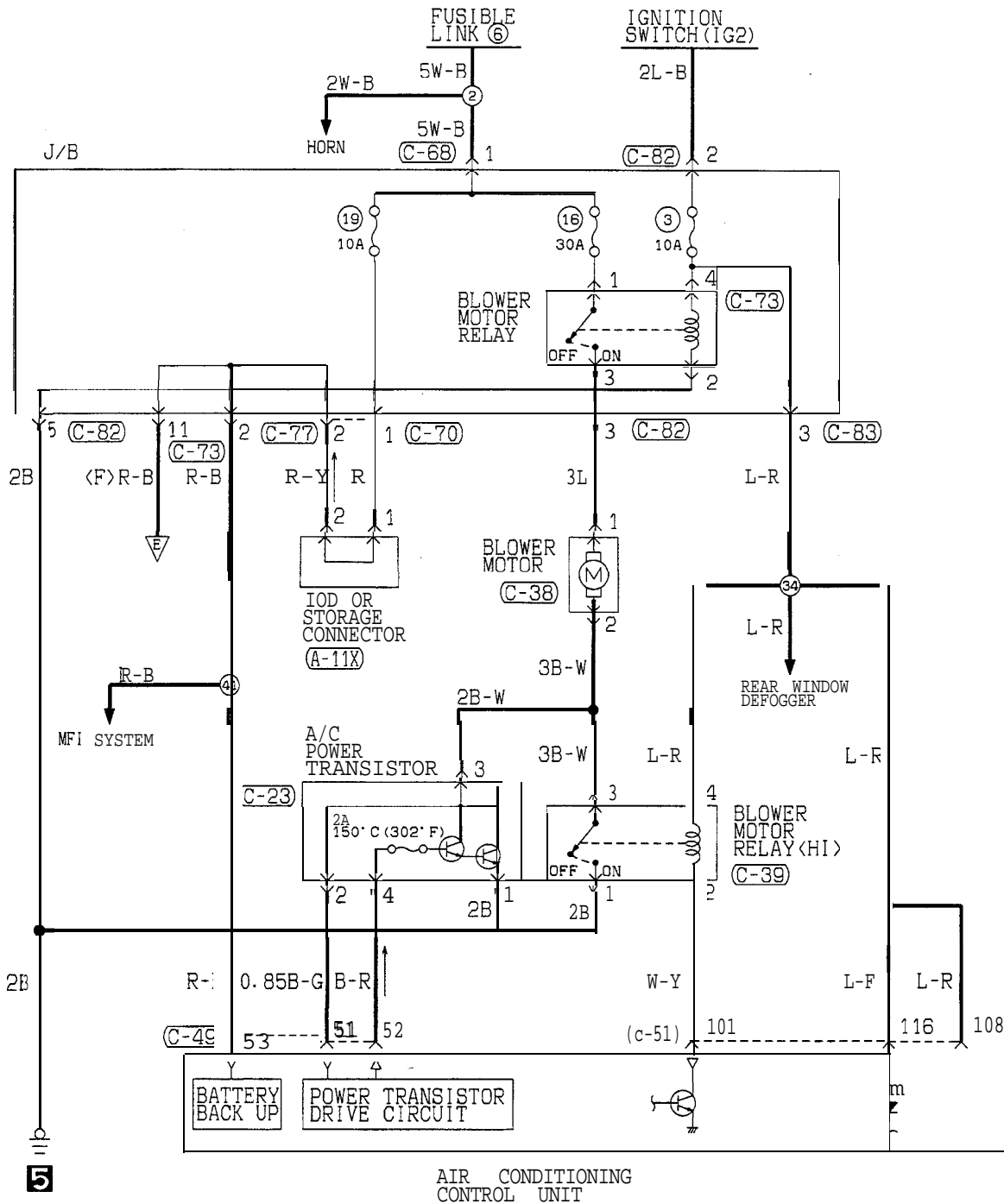

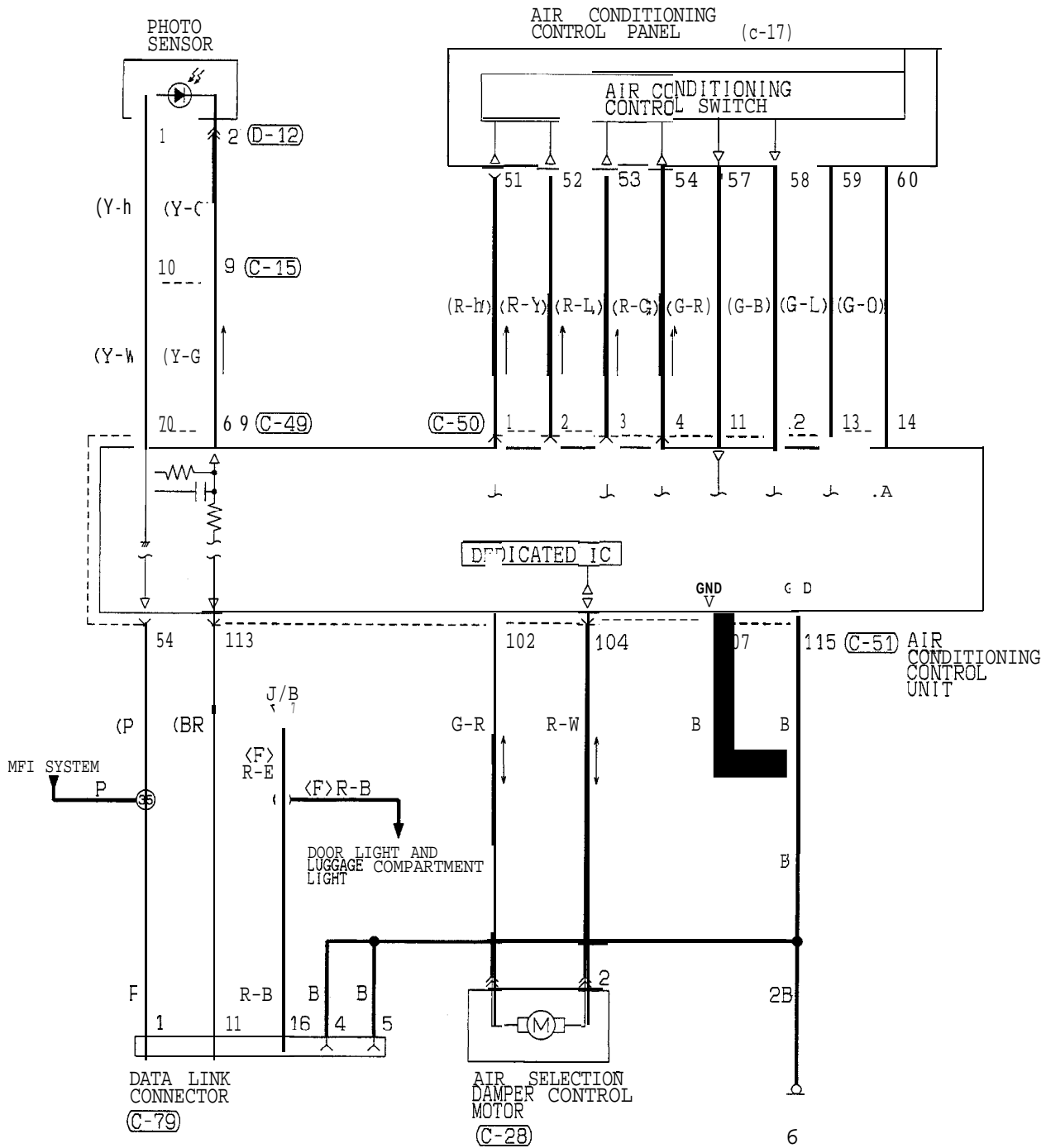

(C-15)

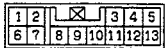

(C-17)

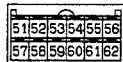

(C-28)



(C-49)

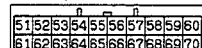

(C-50)

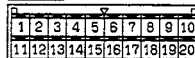

(C-51)

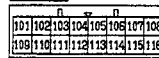

(C-79) FRONT SIDE

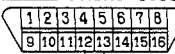

(D-12)



TSB Revision

FULL AUTO AIR CONDITIONING CIRCUIT (1994, 1995 MODELS)  
 <NON TURBO> (FEDERAL) (CONTINUED)

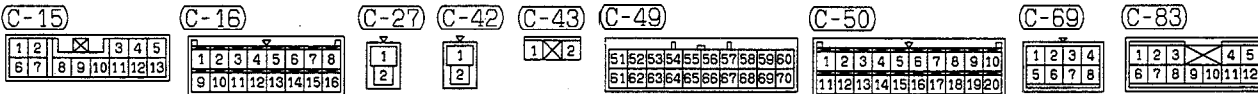
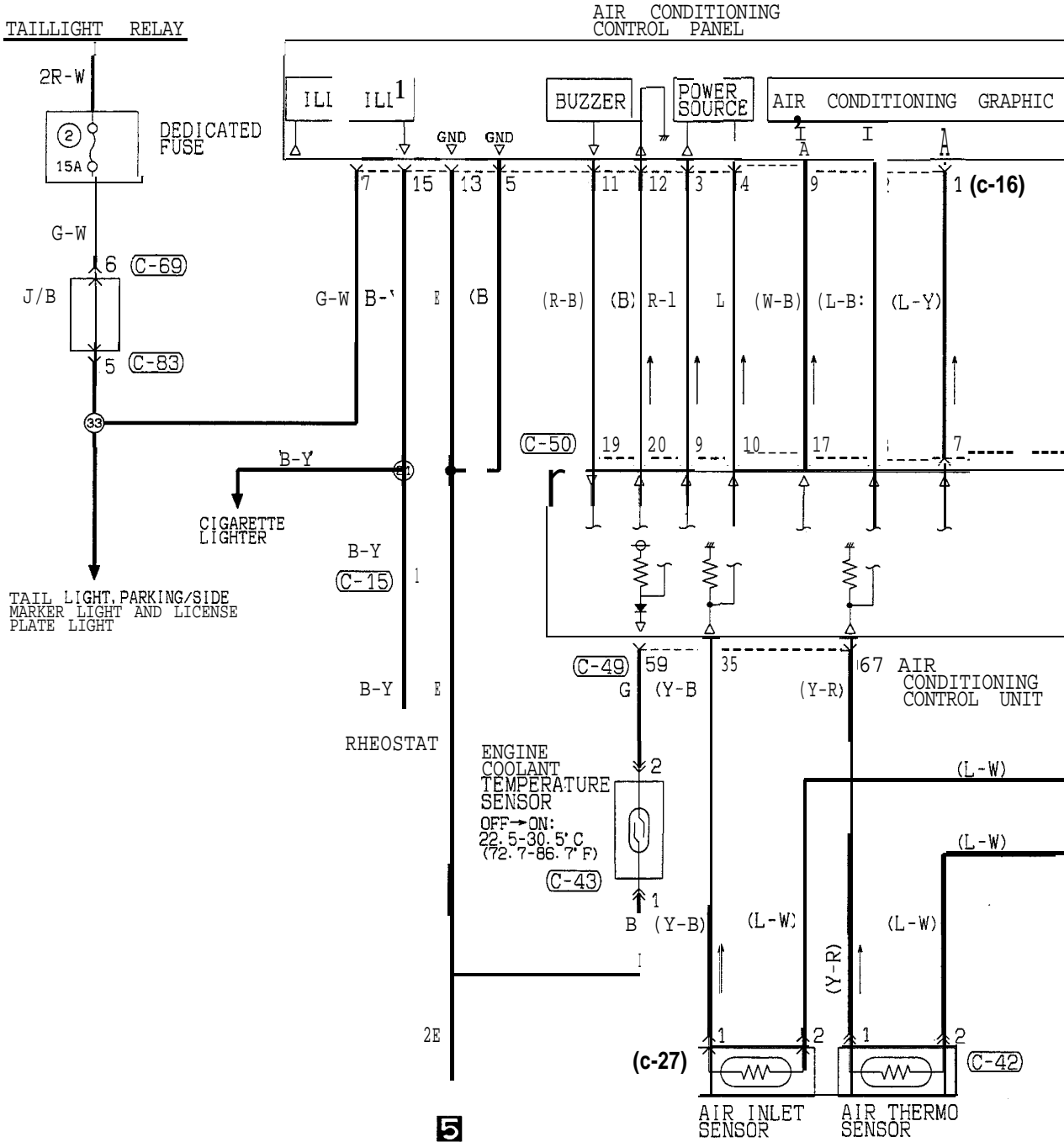

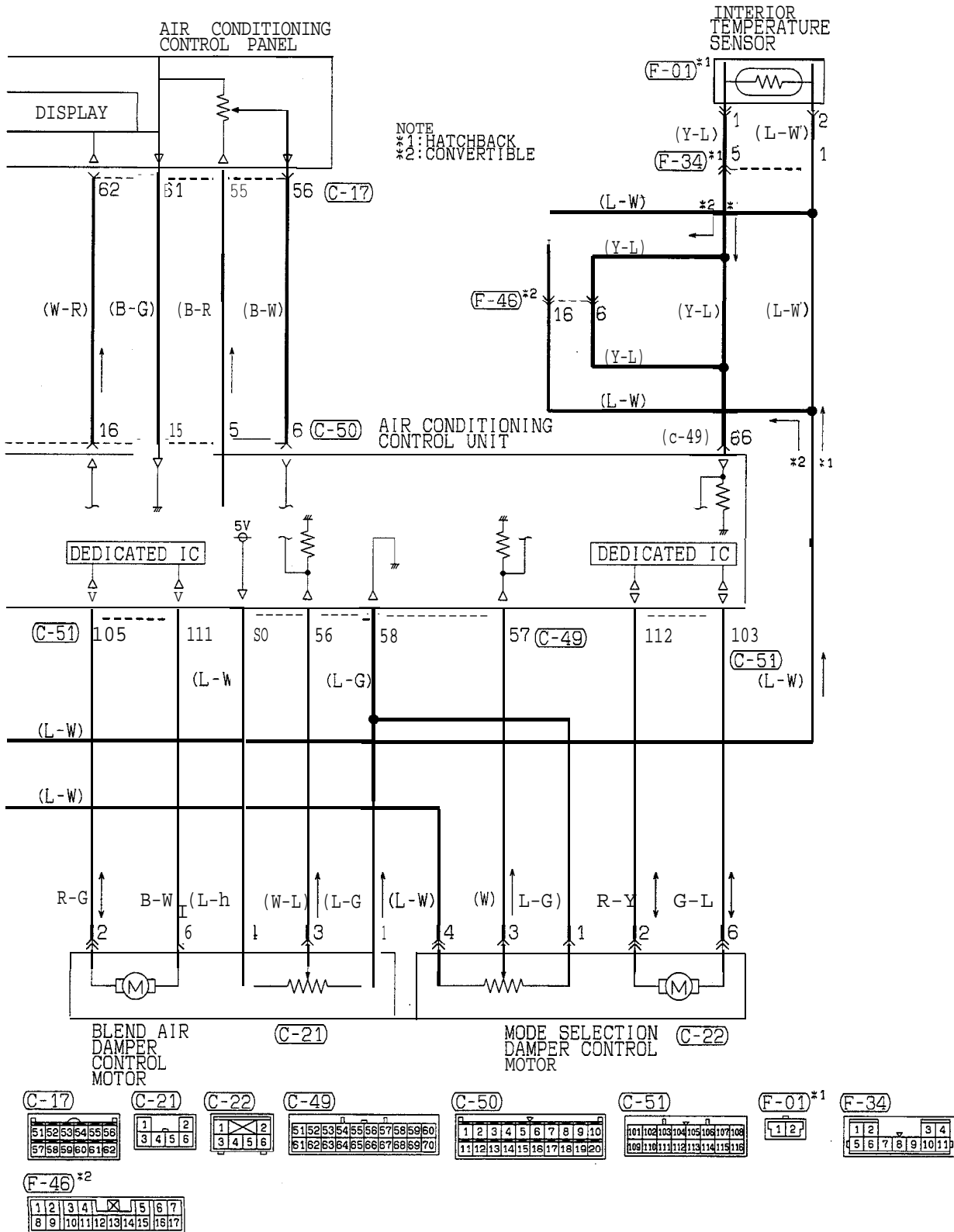

FULL AUTO AIR CONDITIONING CIRCUIT (1994, 1995 MODELS)

<TURBO, NON TURBO (CALIFORNIA)>

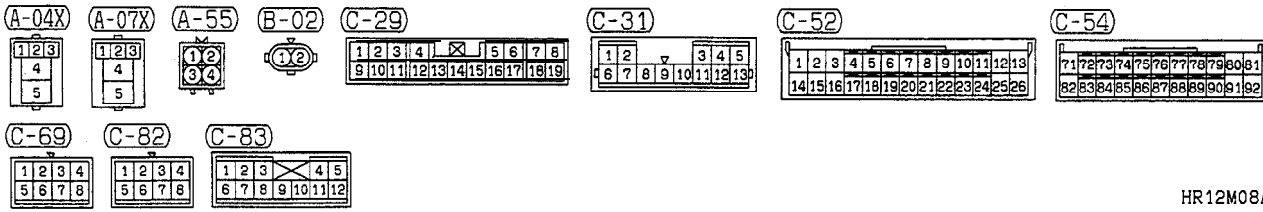
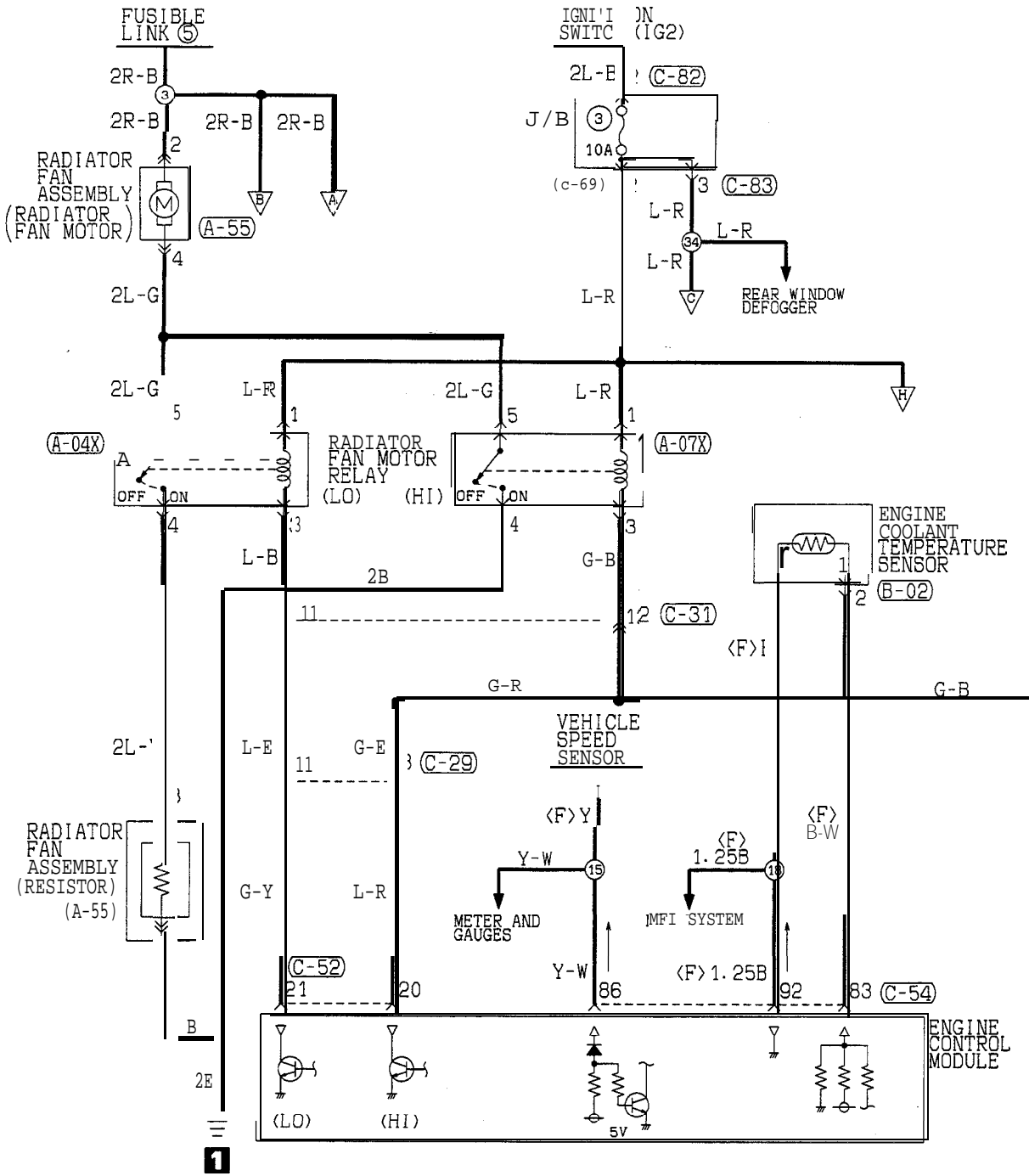

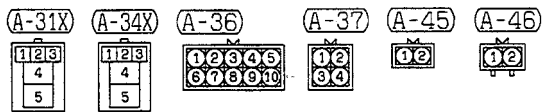
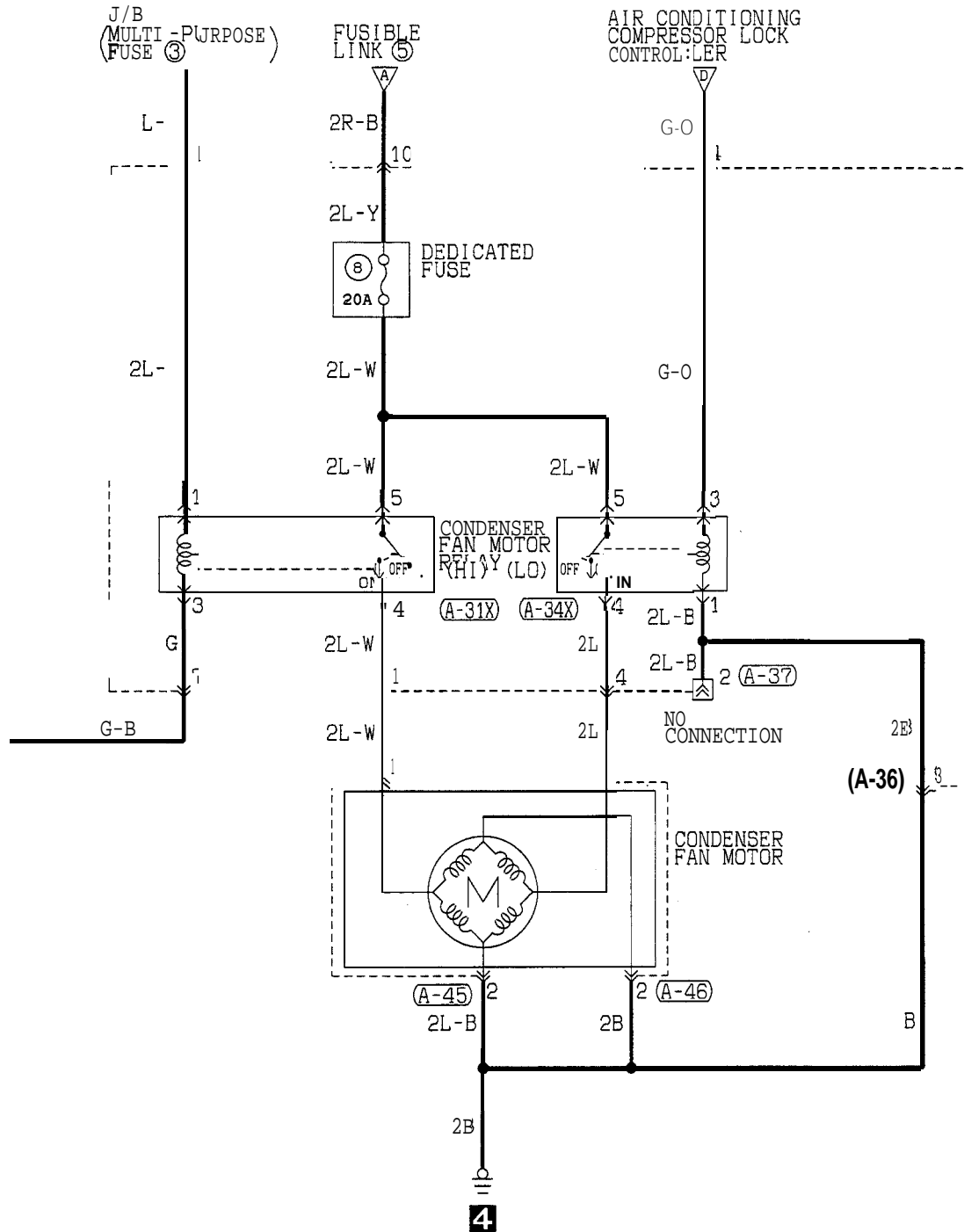

TSB Revision



FULL AUTO AIR CONDITIONING CIRCUIT (1994, 1995 MODELS)  
 <TURBO, NON TURBO (CALIFORNIA)> (CONTINUED)

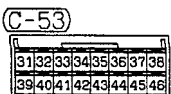
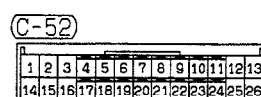
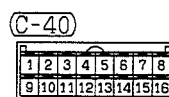
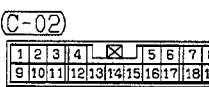
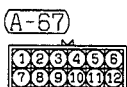
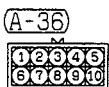
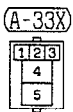
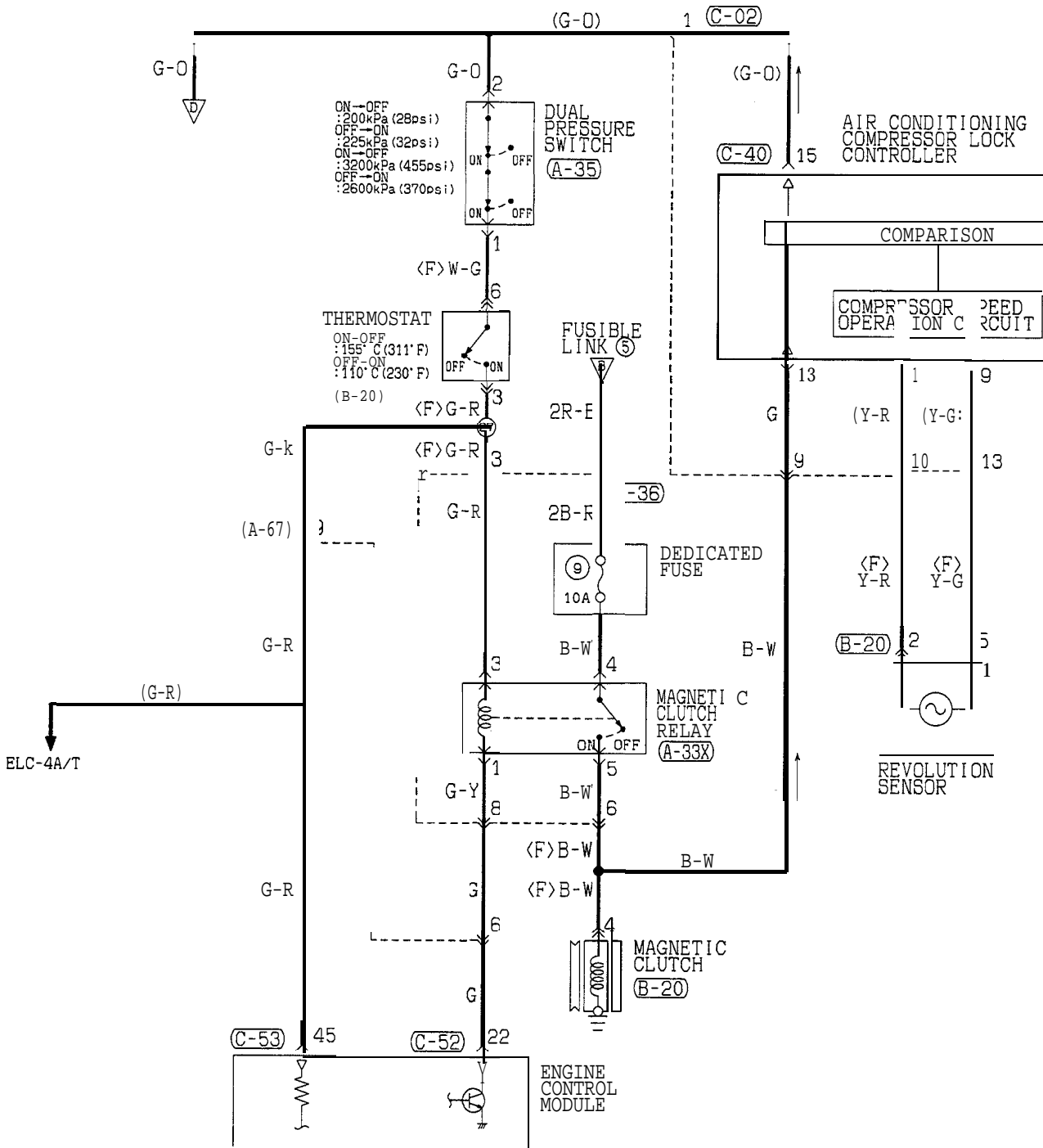

TSB Revision

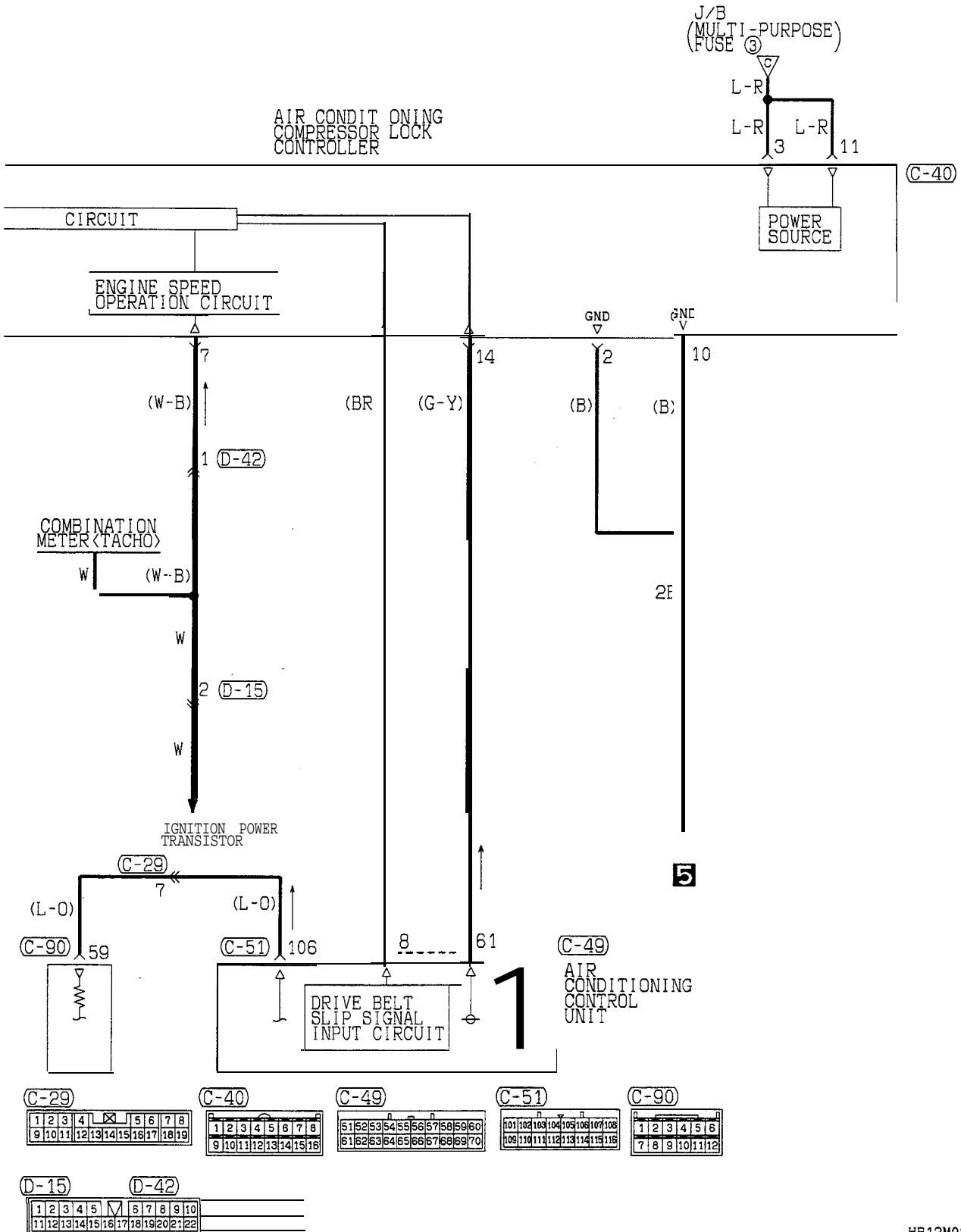

C-29

1	2	3	4	5	6	7	8			
9	10	11	12	13	14	15	16	17	18	19

C-40

1	2	3	4	5	6	7	8
9	10	11	12	13	14	15	16

C-49

51	52	53	54	55	56	57	58	59	60
61	62	63	64	65	66	67	68	69	70

C-51

101	102	103	104	105	106	107	108
109	110	111	112	113	114	115	116

C-90

1	2	3	4	5	6
7	8	9	10	11	12

D-15

1	2	3	4	5	6	7	8	9	10		
11	12	13	14	15	16	17	18	19	20	21	22

D-42

1	2	3	4	5	6	7	8	9	10		
11	12	13	14	15	16	17	18	19	20	21	22

FULL AUTO AIR CONDITIONING CIRCUIT (1994, 1995 MODELS)  
 <TURBO, NON TURBO (CALIFORNIA)> (CONTINUED)

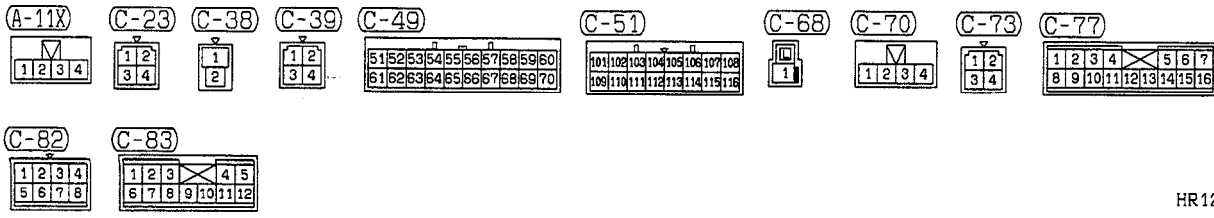
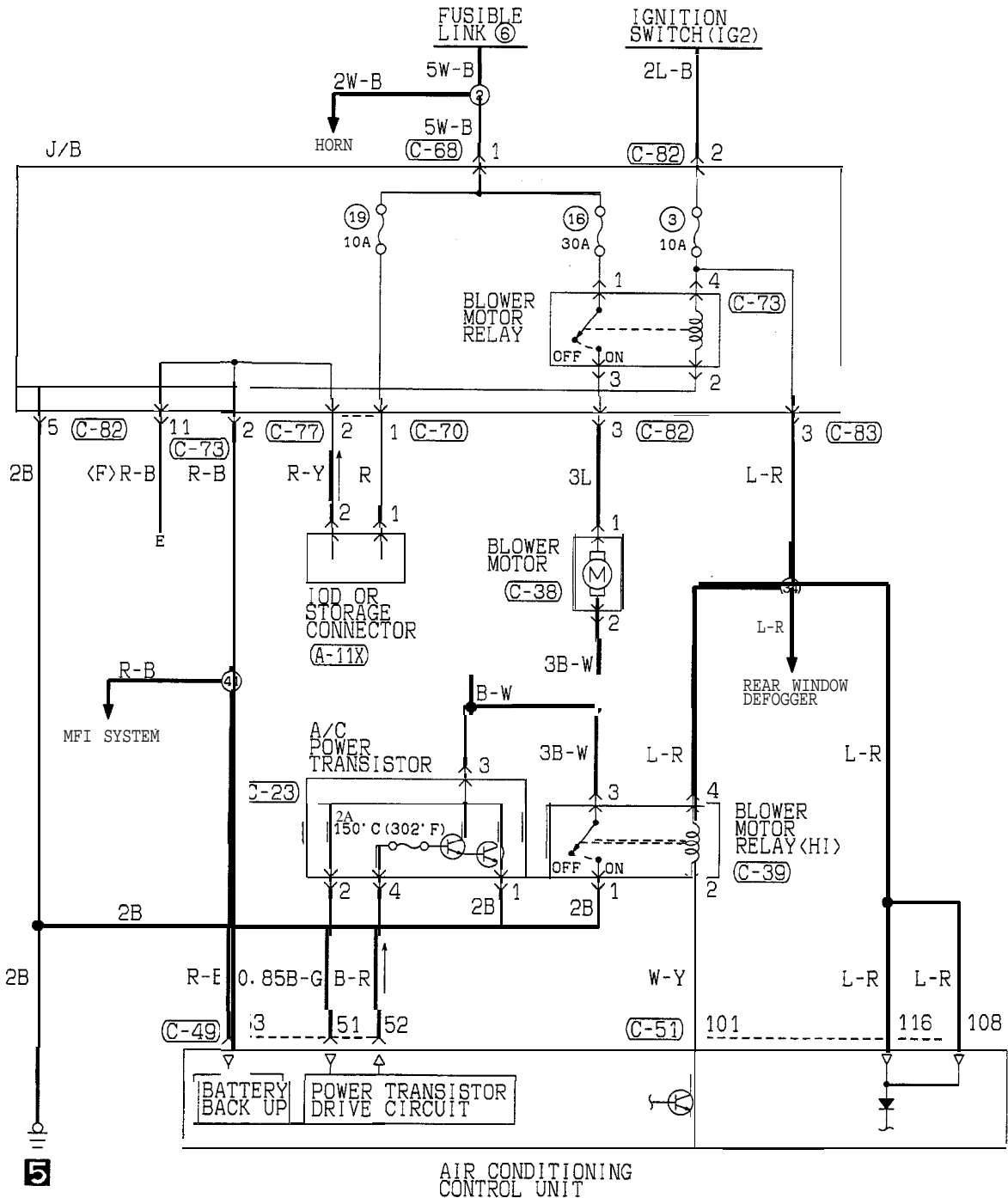

TSB Revision

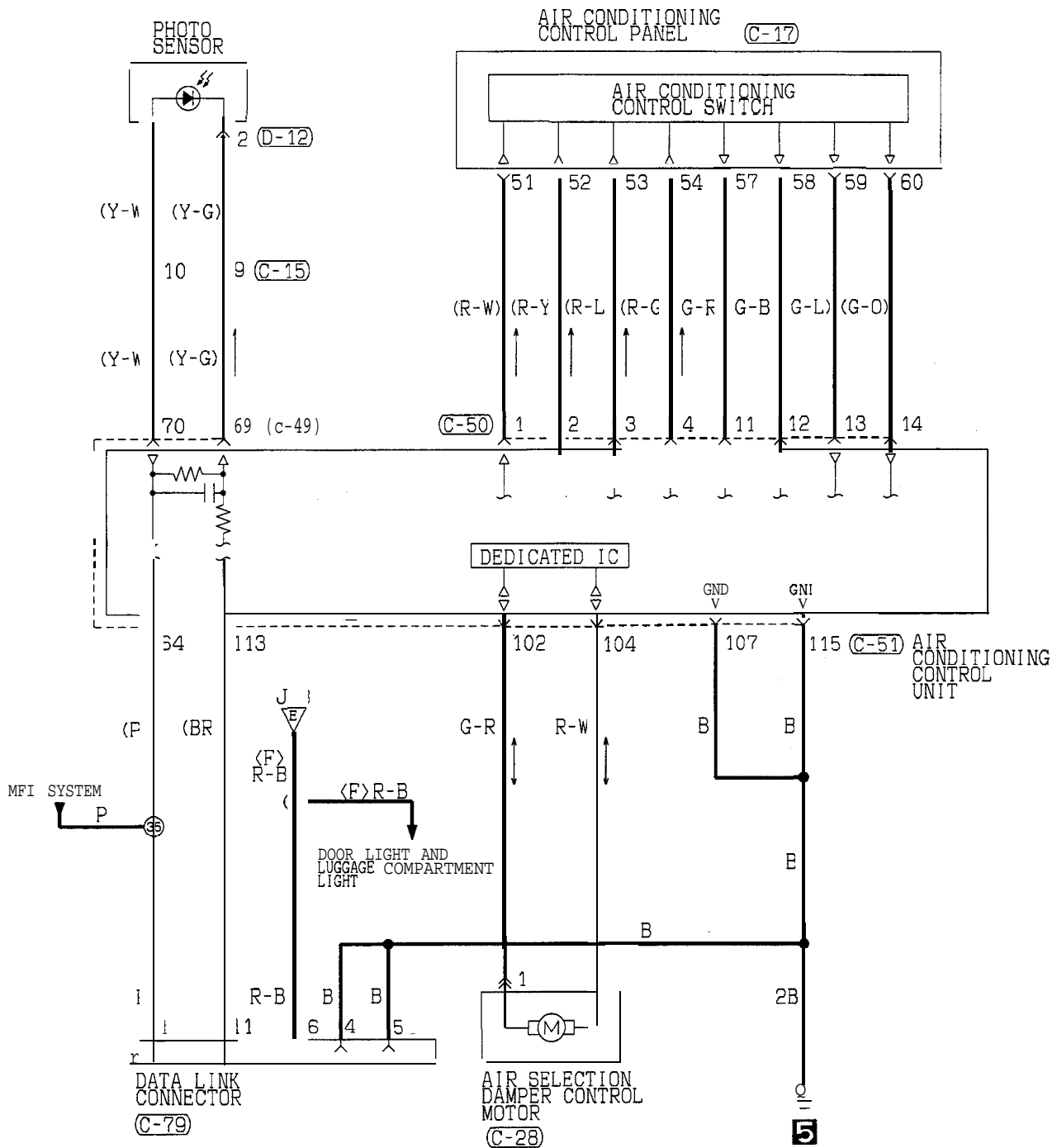

(C-15)

1	2	3	4	5
6	7	8	9	10
11	12	13		

(C-17)

51	52	53	54	55	56
57	58	59	60	61	62

(C-28)

1	2
---	---

(C-49)

51	52	53	54	55	56	57	58	59	60
61	62	63	64	65	66	67	68	69	70

(C-50)

1	2	3	4	5	6	7	8	9	10
11	12	13	14	15	16	17	18	19	20

(C-51)

101	102	103	104	105	106	107	108
109	110	111	112	113	114	115	116

(C-79) FRONT SIDE

1	2	3	4	5	6	7	8
9	10	11	12	13	14	15	16

(D-12)

1	2
---	---

TSB Revision

FULL AUTO AIR CONDITIONING CIRCUIT (1994, 1995 MODELS)  
 <TURBO, NON TURBO (CALIFORNIA)> (CONTINUED)

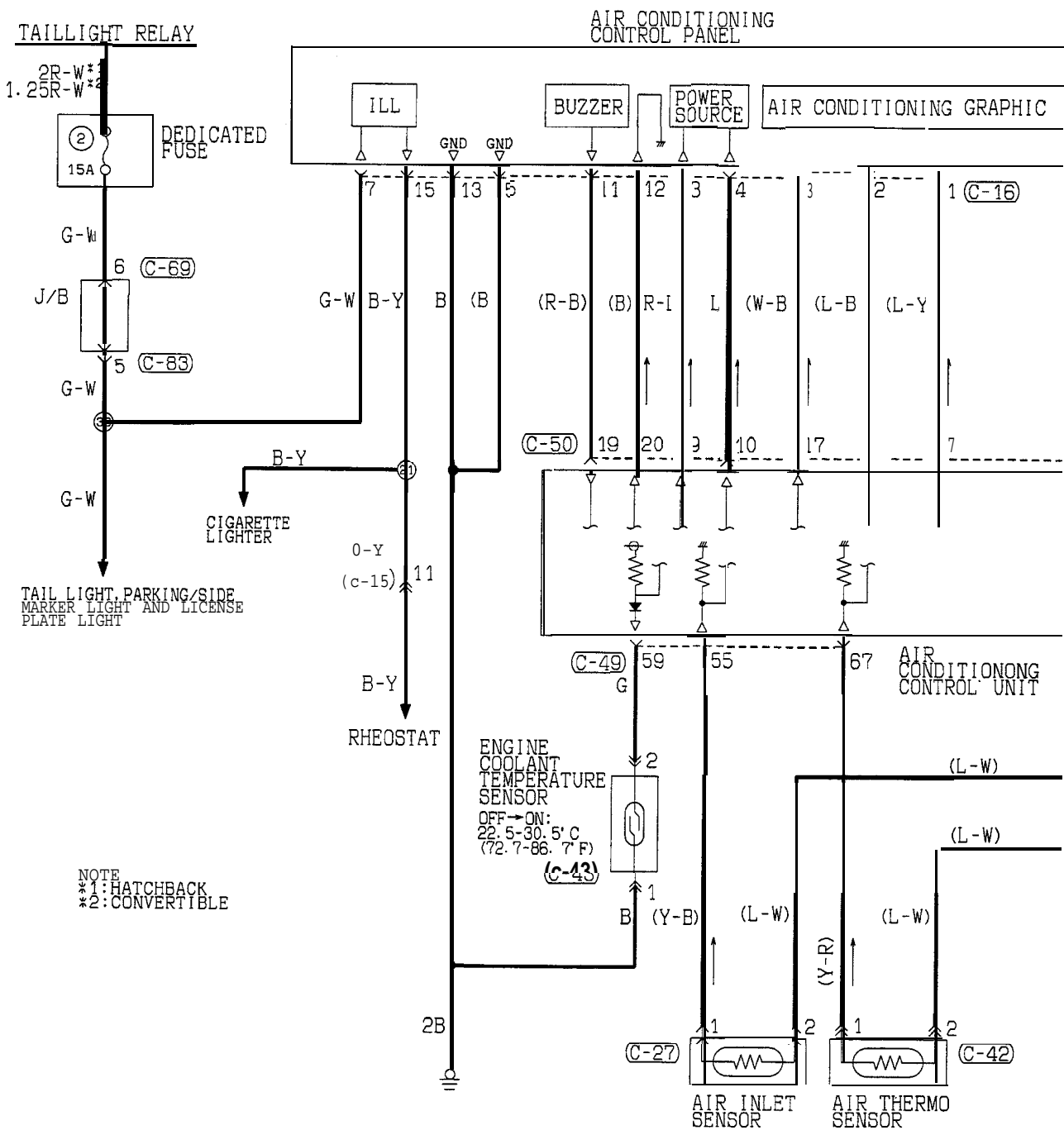

NOTE  
 \*1: HATCHBACK  
 \*2: CONVERTIBLE

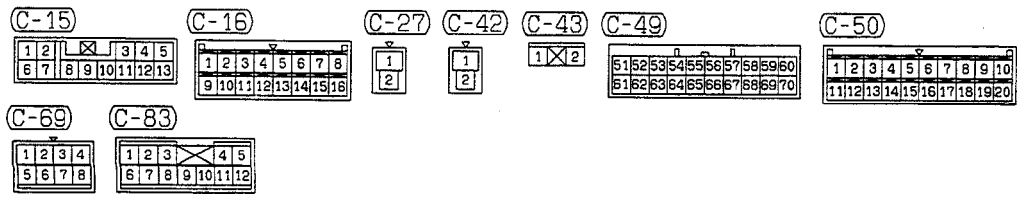

TSB Revision

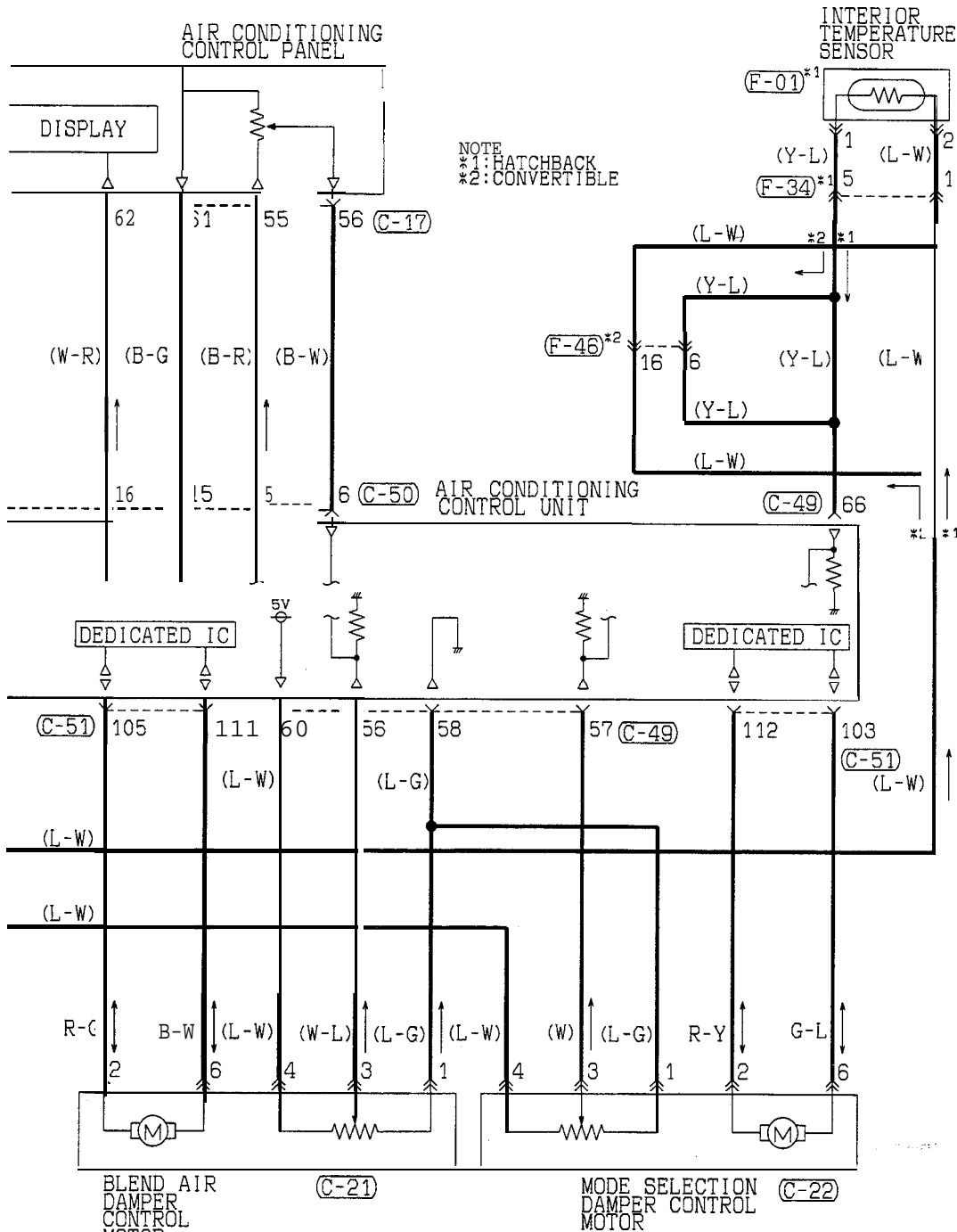

**C-17**

51	52	53	54	55	56
57	58	59	60	61	62

**C-21**

1	2
3	4
5	6

**C-22**

1	2
3	4
5	6

**C-49**

51	52	53	54	55	56	57	58	59	60
61	62	63	64	65	66	67	68	69	70

**C-50**

1	2	3	4	5	6	7	8	9	10
11	12	13	14	15	16	17	18	19	20

**C-51**

101	102	103	104	105	106	107	108
109	110	111	112	113	114	115	116

**F-01**\*1

1	2
---	---

**F-34**\*1

1	2	3	4
5	6	7	8
9	10	11	12

**F-46**\*2

1	2	3	4	5	6	7
8	9	10	11	12	13	14
15	16	17				

**TSB Revision**

FULL AUTO AIR CONDITIONING CIRCUIT (FROM 1996 MODELS)

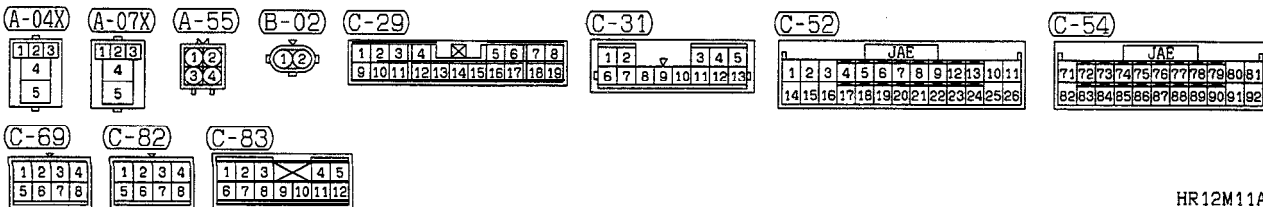
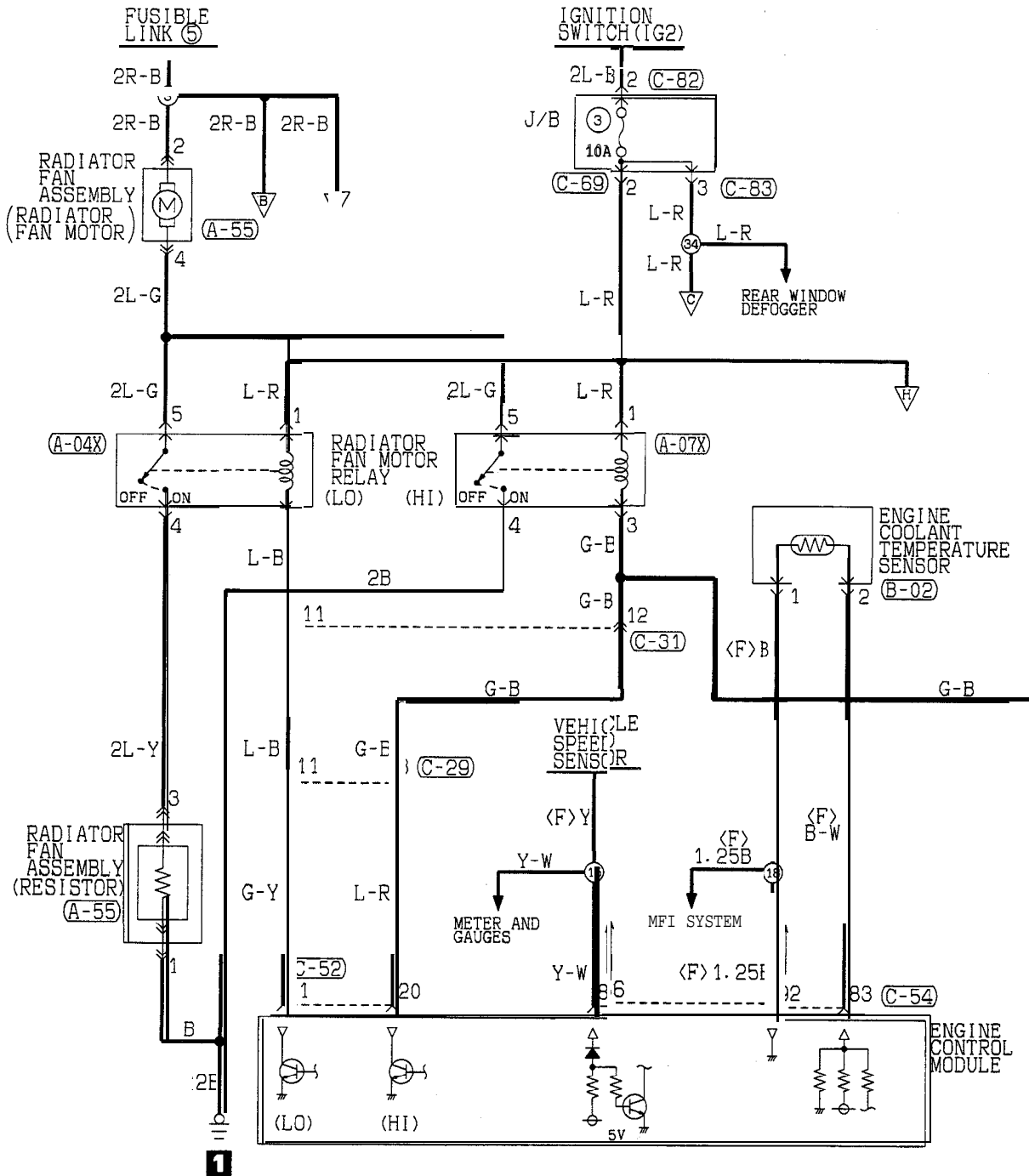

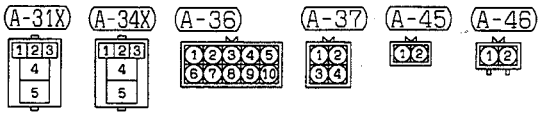
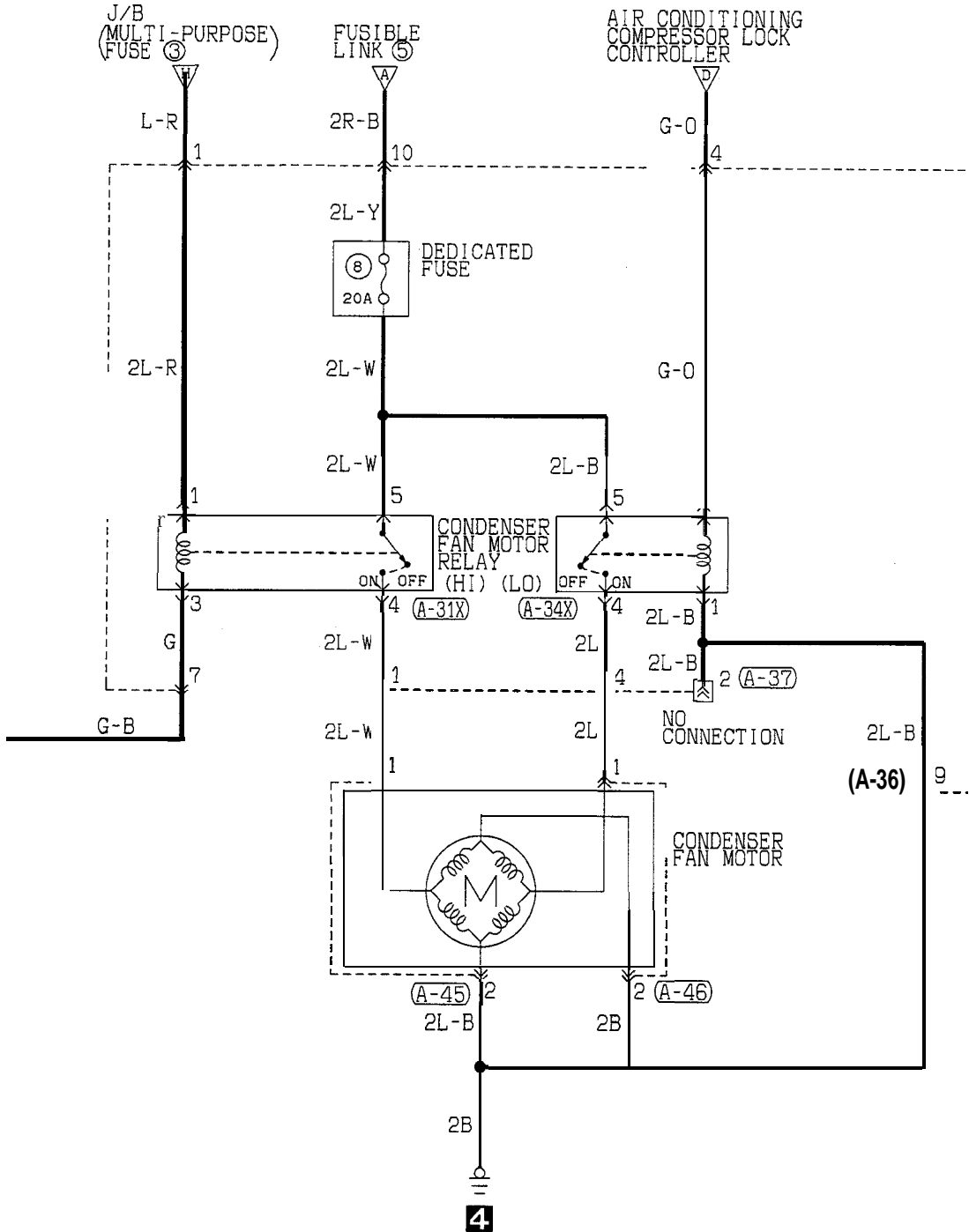

TSB Revision



FULL AUTO AIR CONDITIONING CIRCUIT (FROM 1996 MODELS) (CONTINUED)

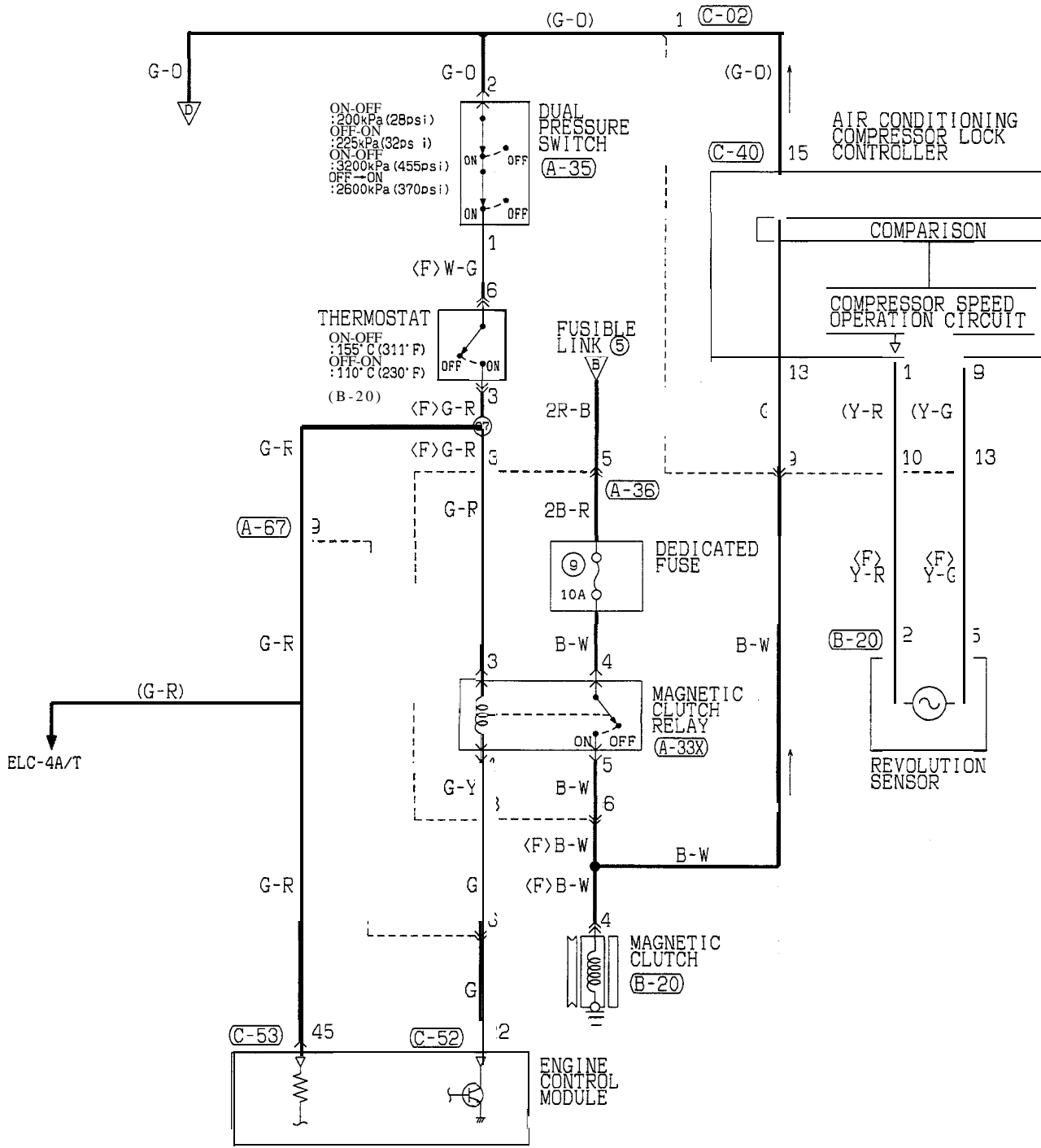

<b>A-33X</b>	<b>A-35</b>	<b>A-36</b>	<b>A-67</b>	<b>B-20</b>	<b>C-02</b>	<b>C-40</b>	<b>C-52</b>																																																																																																																						
<table border="1"> <tr><td>1</td><td>2</td><td>3</td></tr> <tr><td>4</td><td></td><td></td></tr> <tr><td>5</td><td></td><td></td></tr> </table>	1	2	3	4			5			<table border="1"> <tr><td>1</td><td>2</td></tr> </table>	1	2	<table border="1"> <tr><td>1</td><td>2</td><td>3</td><td>4</td><td>5</td><td>6</td></tr> <tr><td>7</td><td>8</td><td>9</td><td>10</td><td></td><td></td></tr> </table>	1	2	3	4	5	6	7	8	9	10			<table border="1"> <tr><td>1</td><td>2</td><td>3</td><td>4</td><td>5</td><td>6</td><td>7</td><td>8</td></tr> <tr><td>9</td><td>10</td><td>11</td><td>12</td><td>13</td><td>14</td><td>15</td><td>16</td></tr> </table>	1	2	3	4	5	6	7	8	9	10	11	12	13	14	15	16	<table border="1"> <tr><td>1</td><td>2</td><td>3</td><td>4</td><td>5</td><td>6</td><td>7</td><td>8</td></tr> <tr><td>9</td><td>10</td><td>11</td><td>12</td><td>13</td><td>14</td><td>15</td><td>16</td></tr> </table>	1	2	3	4	5	6	7	8	9	10	11	12	13	14	15	16	<table border="1"> <tr><td>1</td><td>2</td><td>3</td><td>4</td><td>5</td><td>6</td><td>7</td><td>8</td><td>9</td><td>10</td><td>11</td><td>12</td><td>13</td><td>14</td><td>15</td><td>16</td></tr> <tr><td>17</td><td>18</td><td>19</td><td>20</td><td>21</td><td>22</td><td>23</td><td>24</td><td>25</td><td>26</td><td></td><td></td><td></td><td></td><td></td><td></td></tr> </table>	1	2	3	4	5	6	7	8	9	10	11	12	13	14	15	16	17	18	19	20	21	22	23	24	25	26							<table border="1"> <tr><td>1</td><td>2</td><td>3</td><td>4</td><td>5</td><td>6</td><td>7</td><td>8</td><td>9</td><td>10</td><td>11</td><td>12</td><td>13</td><td>14</td><td>15</td><td>16</td></tr> <tr><td>17</td><td>18</td><td>19</td><td>20</td><td>21</td><td>22</td><td>23</td><td>24</td><td>25</td><td>26</td><td></td><td></td><td></td><td></td><td></td><td></td></tr> </table>	1	2	3	4	5	6	7	8	9	10	11	12	13	14	15	16	17	18	19	20	21	22	23	24	25	26						
1	2	3																																																																																																																											
4																																																																																																																													
5																																																																																																																													
1	2																																																																																																																												
1	2	3	4	5	6																																																																																																																								
7	8	9	10																																																																																																																										
1	2	3	4	5	6	7	8																																																																																																																						
9	10	11	12	13	14	15	16																																																																																																																						
1	2	3	4	5	6	7	8																																																																																																																						
9	10	11	12	13	14	15	16																																																																																																																						
1	2	3	4	5	6	7	8	9	10	11	12	13	14	15	16																																																																																																														
17	18	19	20	21	22	23	24	25	26																																																																																																																				
1	2	3	4	5	6	7	8	9	10	11	12	13	14	15	16																																																																																																														
17	18	19	20	21	22	23	24	25	26																																																																																																																				
<b>C-53</b>	<table border="1"> <tr><td colspan="16">JAE</td></tr> <tr><td>31</td><td>32</td><td>33</td><td>34</td><td>35</td><td>36</td><td>37</td><td>38</td><td></td><td></td><td></td><td></td><td></td><td></td><td></td><td></td></tr> <tr><td>39</td><td>40</td><td>41</td><td>42</td><td>43</td><td>44</td><td>45</td><td>46</td><td></td><td></td><td></td><td></td><td></td><td></td><td></td><td></td></tr> </table>							JAE																31	32	33	34	35	36	37	38									39	40	41	42	43	44	45	46																																																																														
JAE																																																																																																																													
31	32	33	34	35	36	37	38																																																																																																																						
39	40	41	42	43	44	45	46																																																																																																																						

TSB Revision

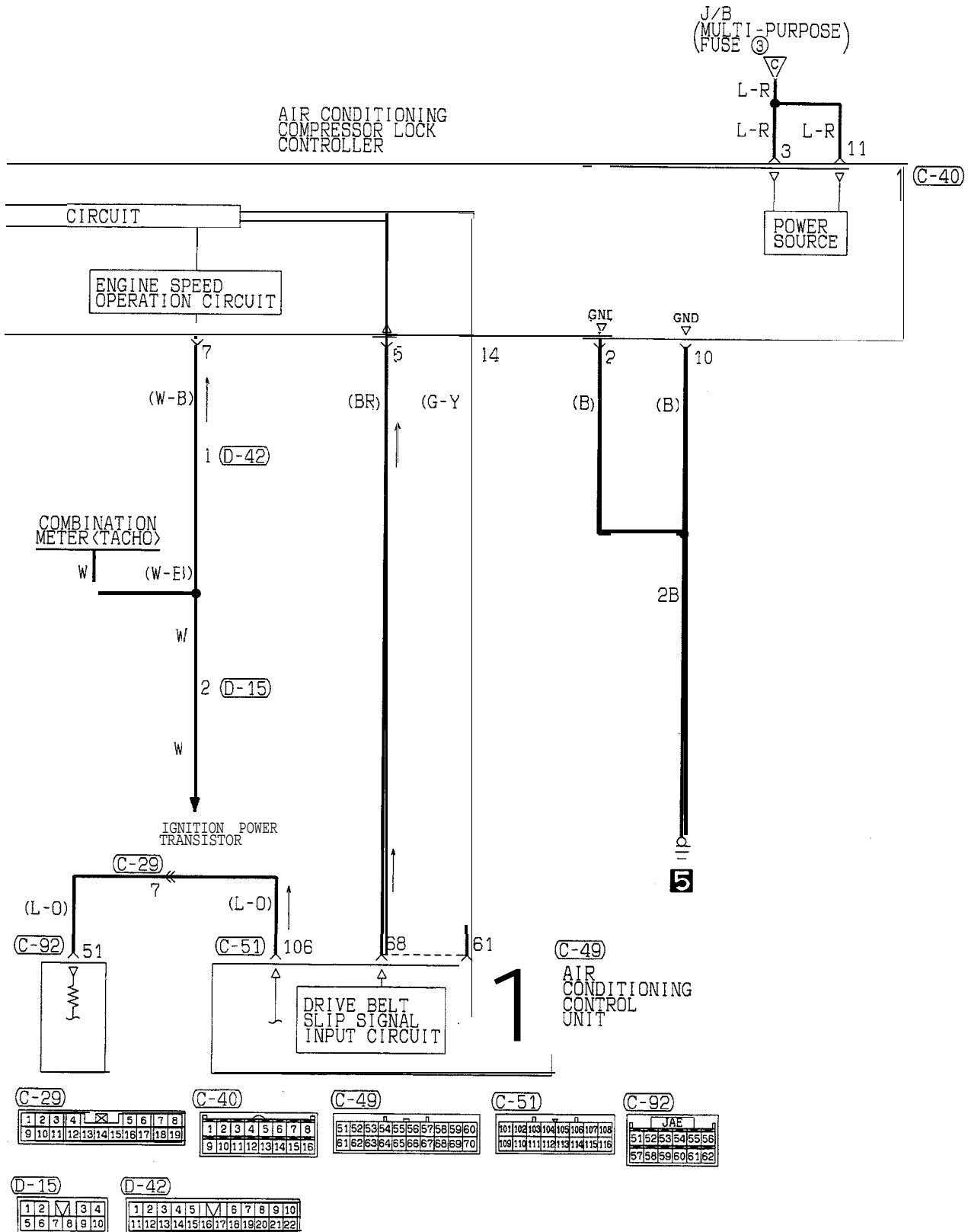

TSB Revision

FULL AUTO AIR CONDITIONING CIRCUIT (FROM 1996 MODELS) (CONTINUED)

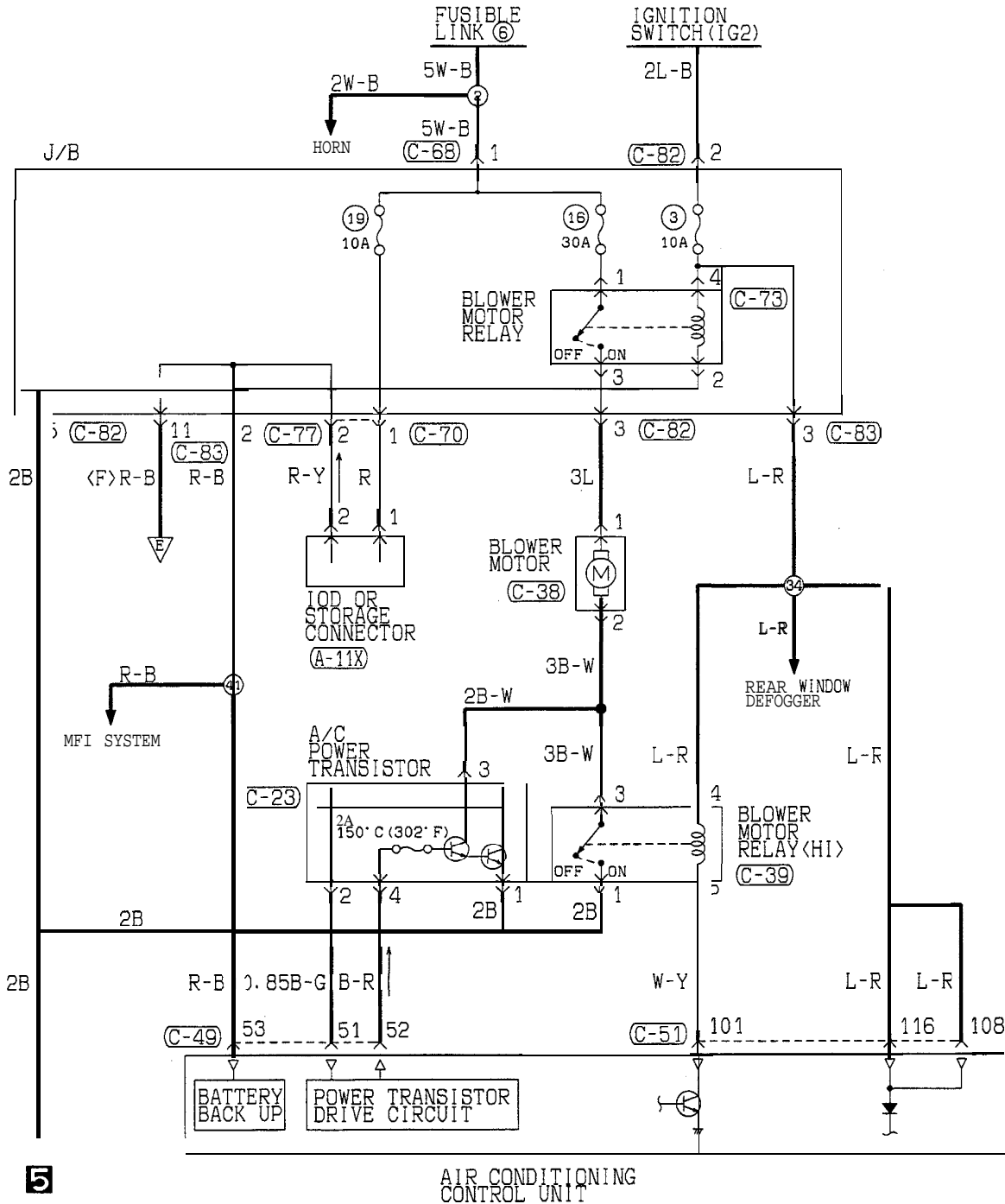

AIR CONDITIONING CONTROL UNIT

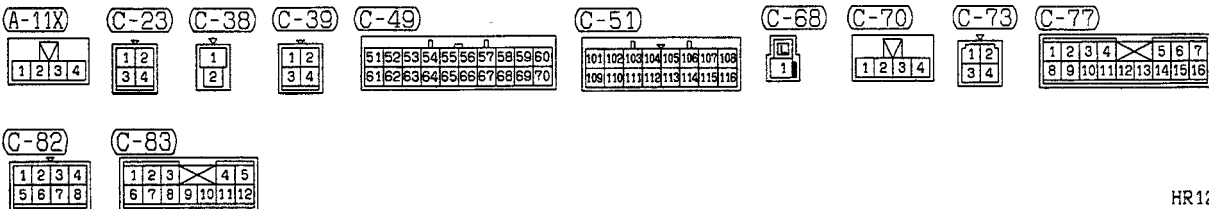

TSB Revision

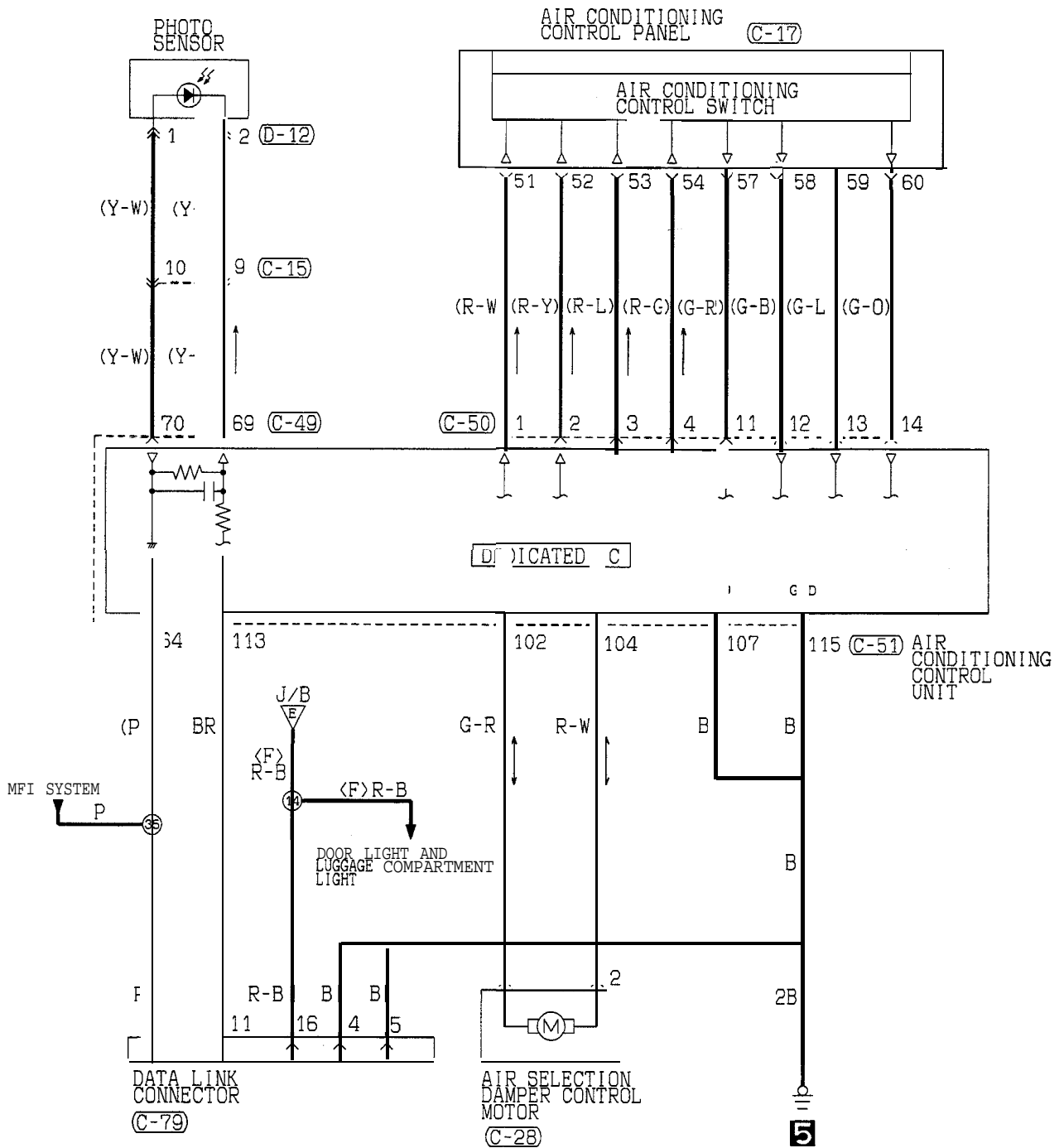

C-15

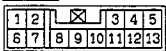

C-17

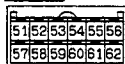

C-28



C-49

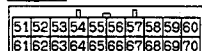

C-50

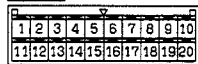

C-51

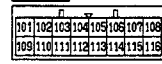

C-79 FRONT SIDE

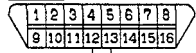

D-12



TSB Revision

FULL AUTO AIR CONDITIONING CIRCUIT (FROM 1996 MODELS) (CONTINUED)

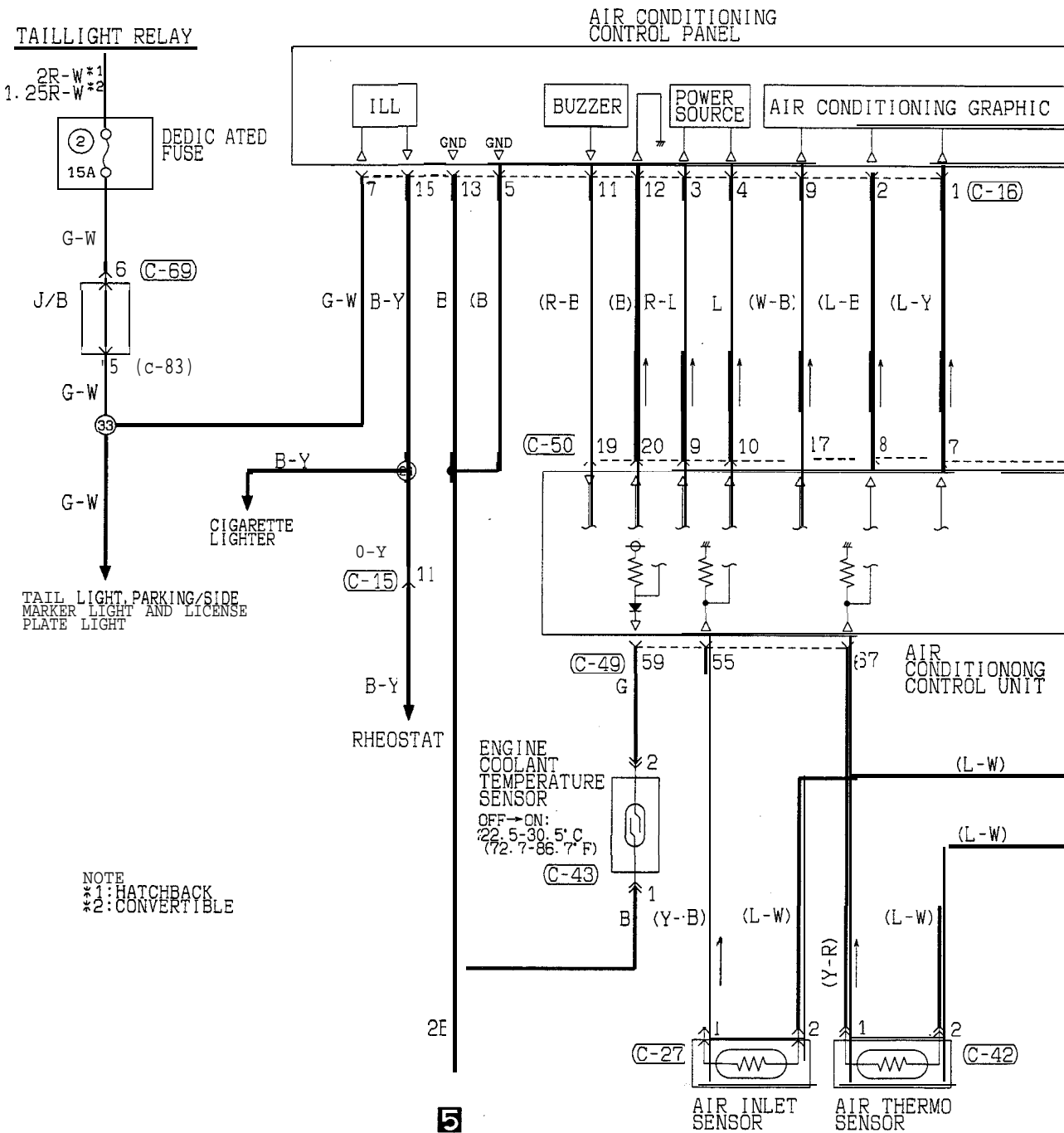

(C-15)

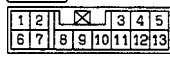

(C-16)

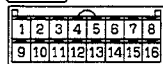

(C-27)



(C-42)



(C-43)



(C-49)

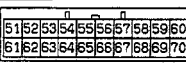

(C-50)

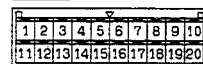

(C-69)



(C-83)

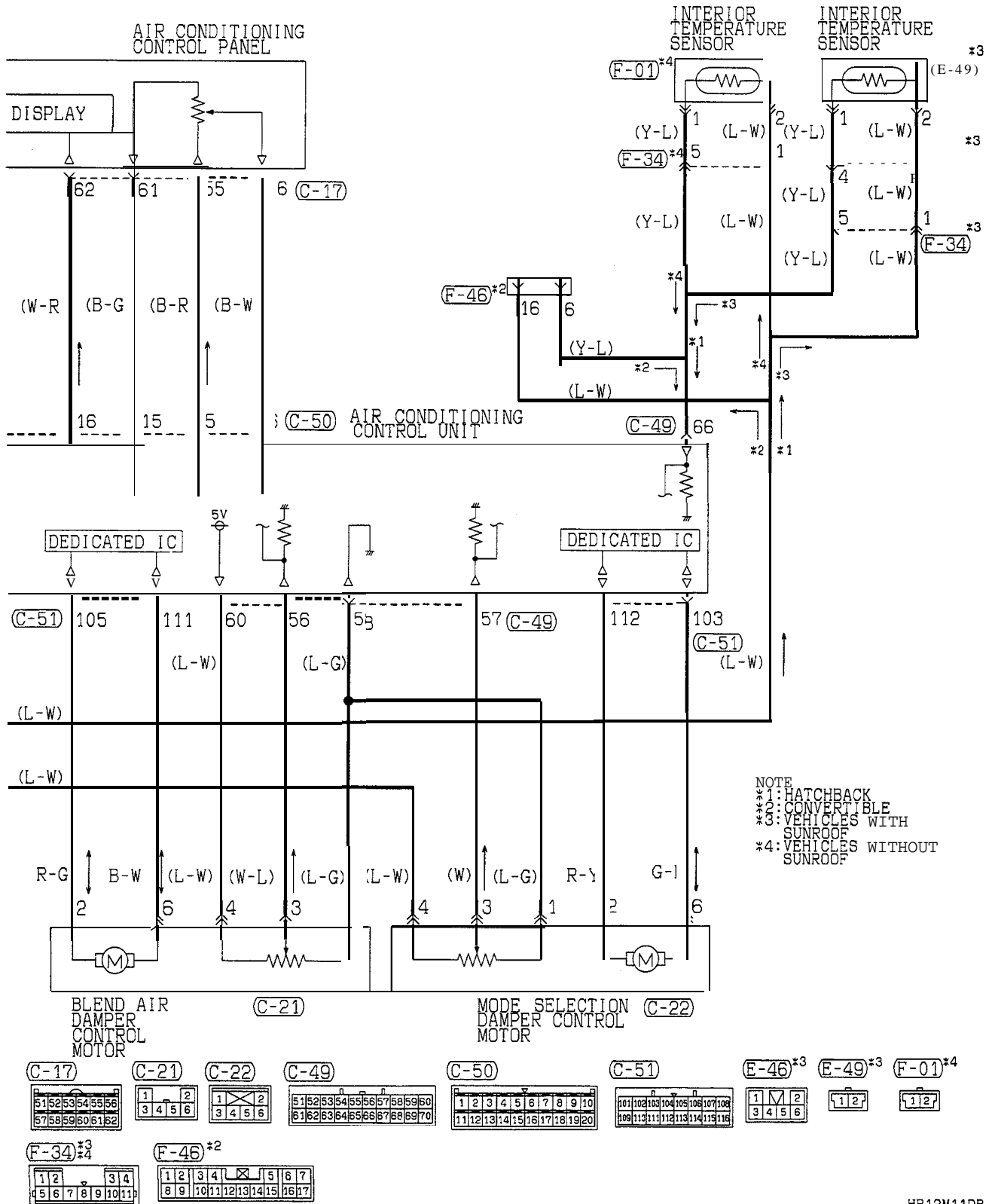

COMPONENT LOCATION

Name	Symbol	Name	Symbol
Air conditioning compressor lock controller	I	Dual pressure switch	C
Air conditioning control unit	E	Engine control module	E
Air-inlet sensor	H	Engine coolant temperature sensor	J
Air-thermo sensor	F	Engine coolant temperature switch*	A
Blower motor relay	L	Interior temperature sensor	N
Blower motor relay (HI)	I	Magnetic clutch relay	B
Condenser fan motor relay (HI)	B	Photo sensor	G
Condenser fan motor relay (LO)	B	Radiator fan motor control relay*	B
Data link connector K (on 1994 models)		Revolution sensor	D
Data link connector M (to 1993 models)		Thermostat*	D

NOTE

• Up to 1993 models

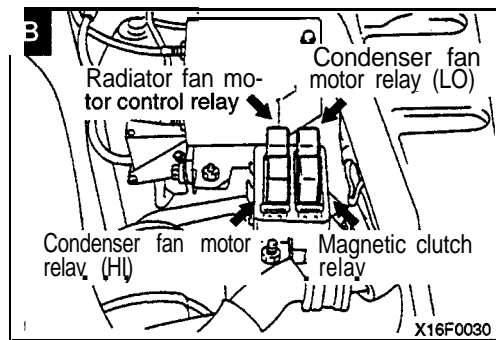
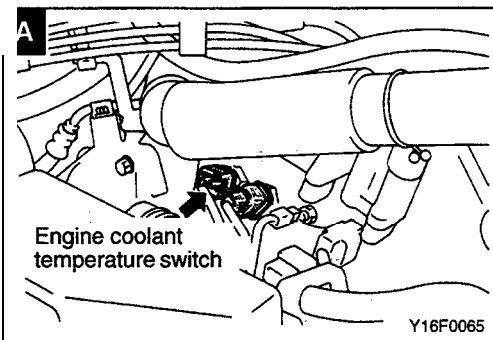
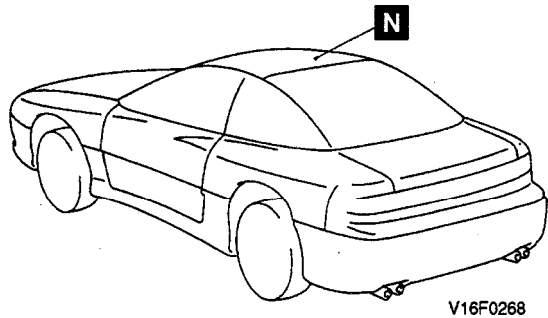
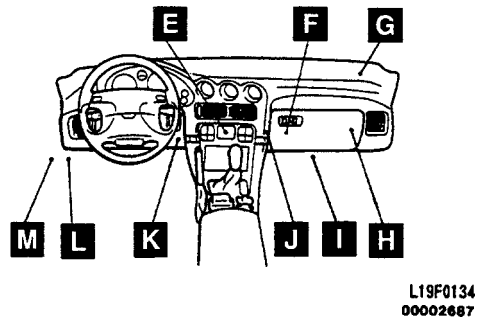
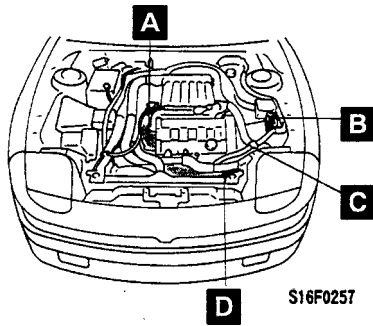

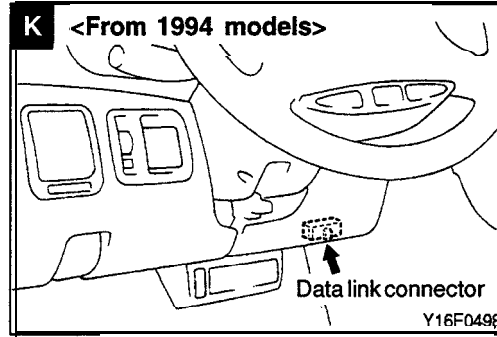
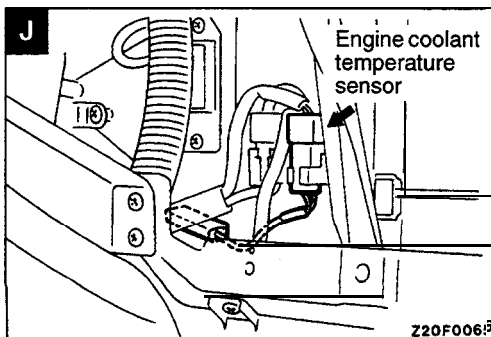
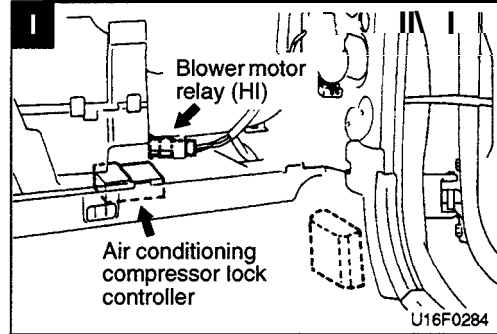
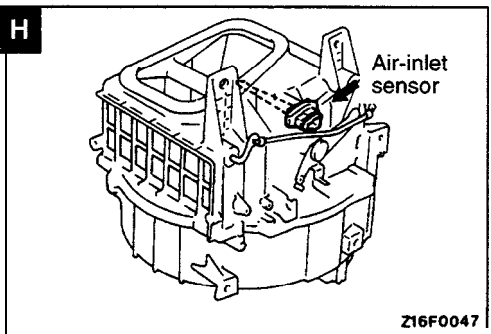
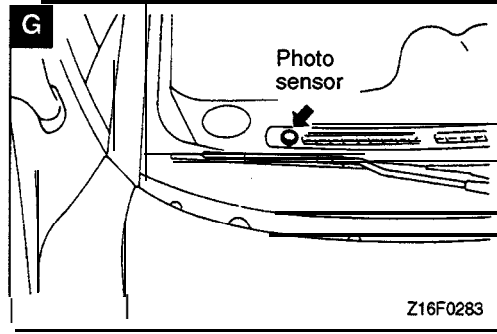
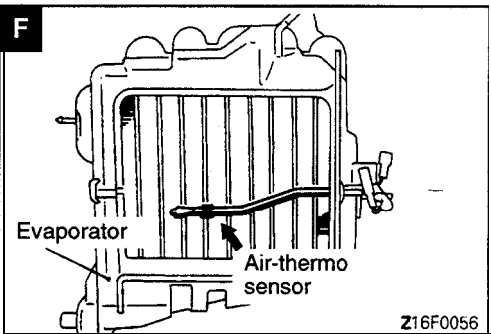
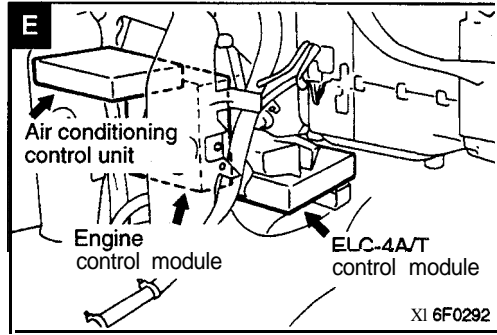
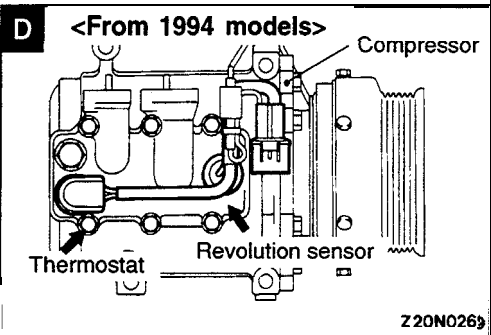
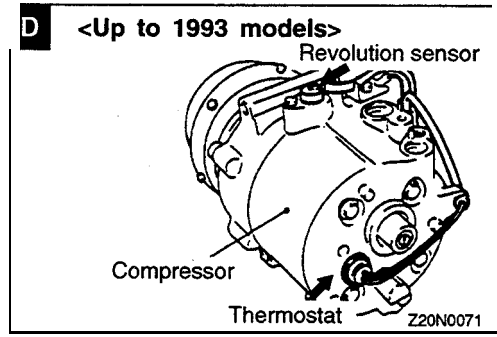
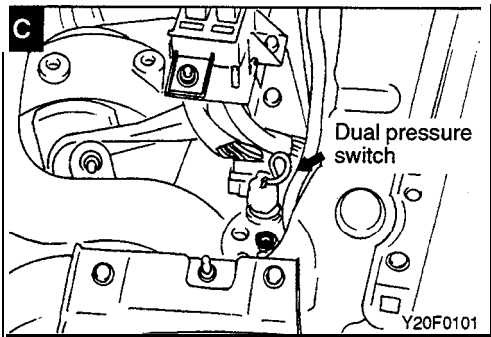



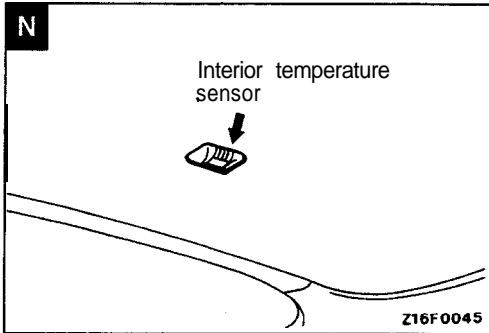
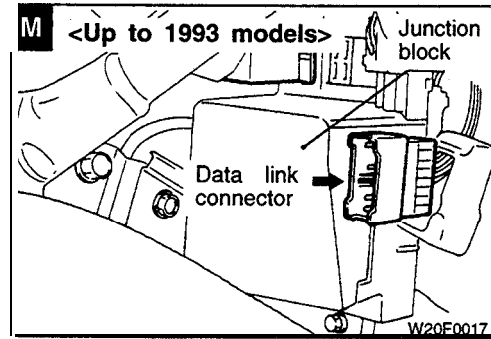
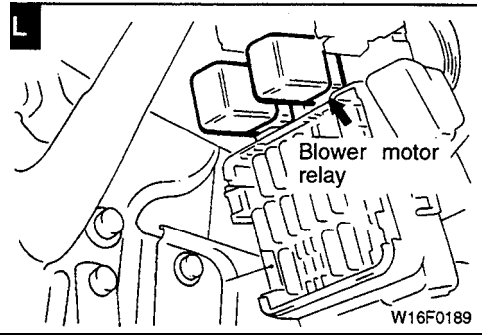

### WINDSHIELD WIPER AND WASHER COMPONENT LOCATION

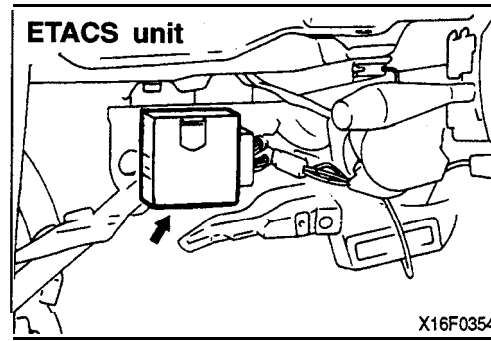
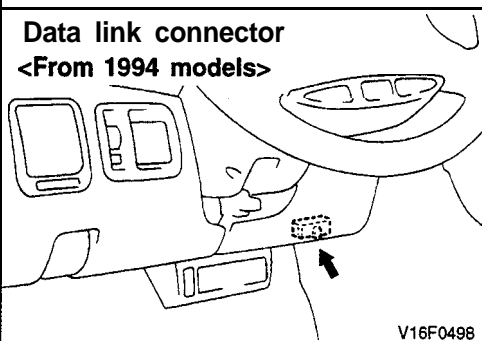
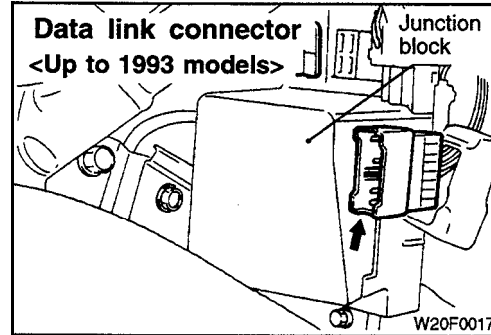
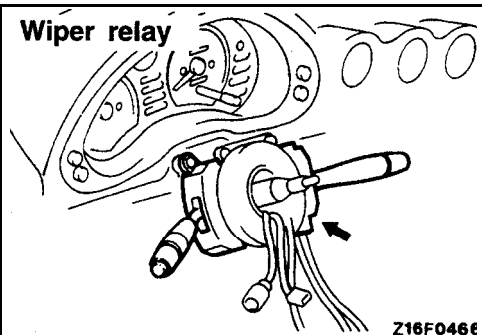

**OPERATION**

**<Low-speed (and high-speed) wiper>**

- When the wiper switch is placed in the LO position with the ignition switch in the ACC or ON position, wipers operate continuously at low speed.
- Placing the wiper switch in the HI position causes the wipers to operate at high speed.

**<Intermittent wiper>**

- If the wiper switch is turned to the INT position when the ignition switch is in the ON or ACC position, the voltage value from the intermittent variable volume switch is input to intermittent time detection circuit.
- The intermittent time detection circuit outputs an H signal at the intermittent time according to the set value of the intermittent variable volume switch and, via OR, turns the Tr on and off to operate the wiper.

**<Auto wiper stop>**

- When the wiper switch is placed in the OFF position, the cam contacts of wiper motor causes current to flow through the auto wiper stop circuit, allowing the wiper blades to cycle before they reach to the stop position.

**<Mist wiper>**

- If the washer switch is on for 0.6 second or less when the ignition switch is at ON or ACC with the wiper switch turned off, the washer liquid will not be poured but transistor will be turned on to operate the wipers one time.

**<Wiper linked with washer>**

- If the washer switch is on for 0.6 second or more when the ignition switch is at ON or ACC with the wiper switch turned off, the washer liquid will be poured and the transistor will be turned on 0.6 second later to operate the wipers two or three times.

**TROUBLESHOOTING HINTS**

Phenomenon		Inspecting method
Wipers do not operate continuously	Washer does not operate.	<ul style="list-style-type: none"> <li>• Check the multi-purpose fuse No. 9</li> </ul>
	Washer operates.	<ul style="list-style-type: none"> <li>• Check the wiper motor. (Refer to GROUP 51–Windshield Wiper and Washer.)</li> <li>• Check the column switch. (Refer to GROUP 51–Windshield Wiper and Washer.)</li> </ul>
Low-speed (or high-speed) wiper operation only is inoperative.		<ul style="list-style-type: none"> <li>• Check the column switch. (Refer to GROUP 51–Windshield Wiper and Washer.)</li> </ul>
Wipers do not operate intermittently. (They operate continuously.)		<ul style="list-style-type: none"> <li>• Check the wiper switch “INT” input signal. (Refer to GROUP 51–Troubleshooting.)</li> <li>• Check the column switch. (Refer to GROUP 51–Windshield Wiper and Washer.)</li> </ul>
Wipers do not stop.		<ul style="list-style-type: none"> <li>• Check the wiper switch “INT” input signal. (Refer to GROUP 51–Troubleshooting.)</li> <li>• Check the column switch. (Refer to GROUP 51–Windshield Wiper and Washer.)</li> <li>• Check the wiper motor. (Refer to GROUP 51–Windshield Wiper and Washer.)</li> </ul>
The intermittent time will not vary even if the variable intermittent wiper control switch is operated.		<ul style="list-style-type: none"> <li>• Check the variable intermittent wiper control switch input signal. (Refer to GROUP S-Troubleshooting.)</li> <li>• Check the column switch. (Refer to GROUP 51–Windshield Wiper and Washer.)</li> </ul>
Even if the washer switch is on for 0.6 second or more, the washer will not operate.	The wipers linked with the washer operate.	<ul style="list-style-type: none"> <li>• Check the washer motor. (Refer to GROUP 51–Windshield Wiper and Washer.)</li> <li>• Check the washer nozzle and washer tube.</li> </ul>
	The wipers linked with the washer do not operate.	<ul style="list-style-type: none"> <li>• Check the washer switch input signal.</li> <li>• Check the washer switch. (Refer to GROUP 51–Windshield Wiper and Washer.)</li> </ul>

WINDSHIELD WIPER AND WASHER CIRCUIT

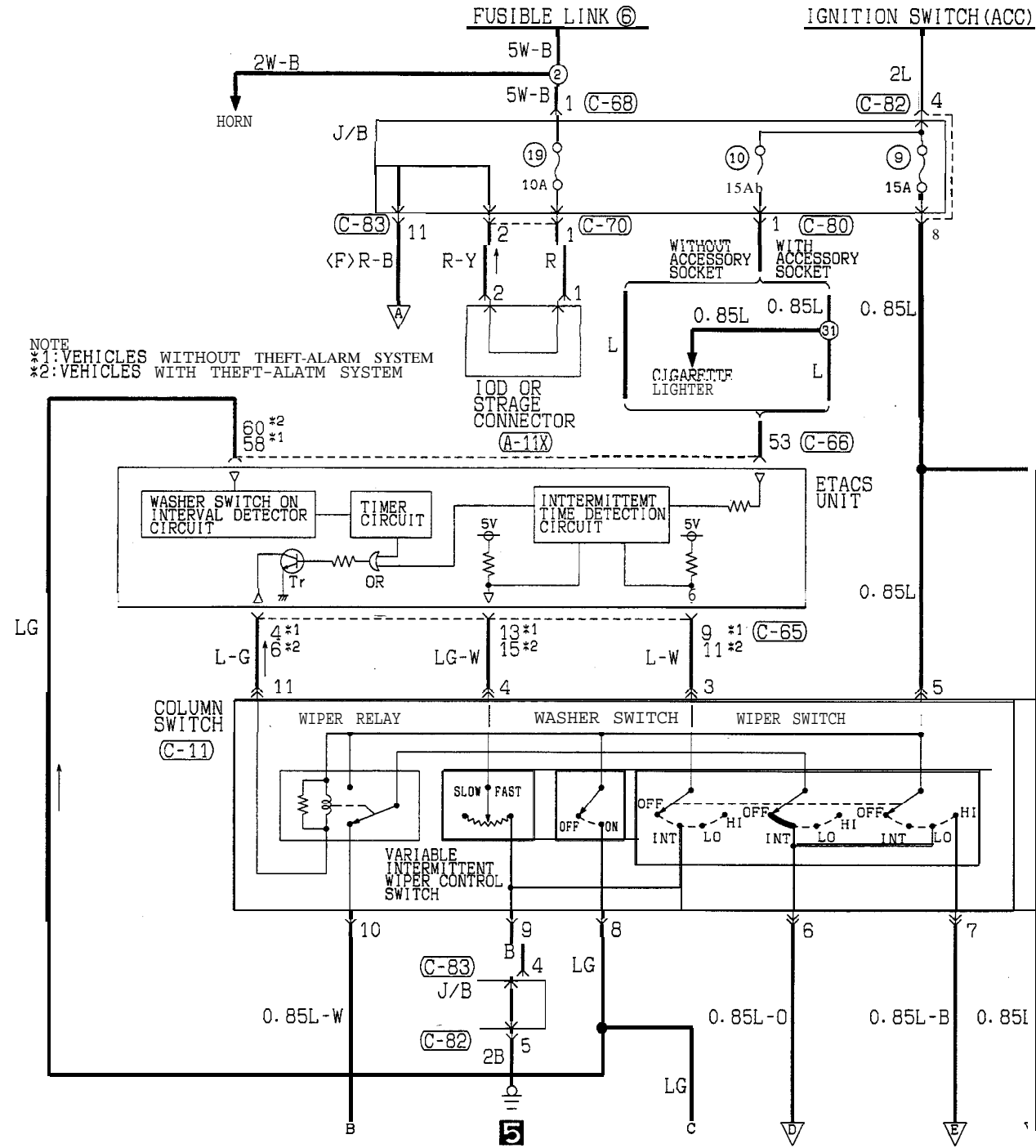

NOTE  
 \*1: VEHICLES WITHOUT THEFT-ALARM SYSTEM  
 \*2: VEHICLES WITH THEFT-ALARM SYSTEM

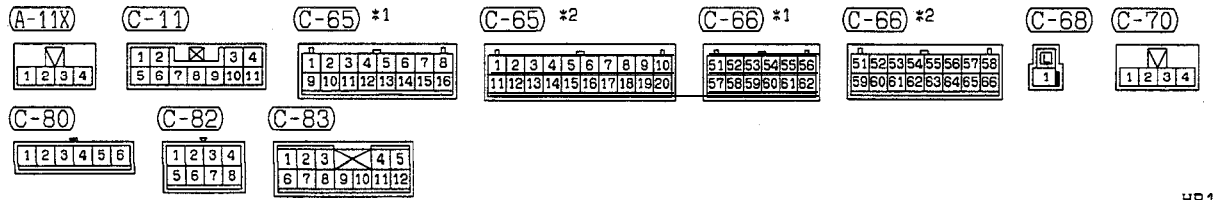

HR13M06AA

TSB Revision

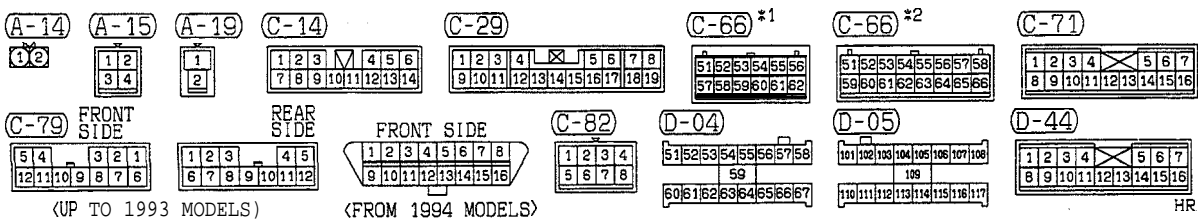
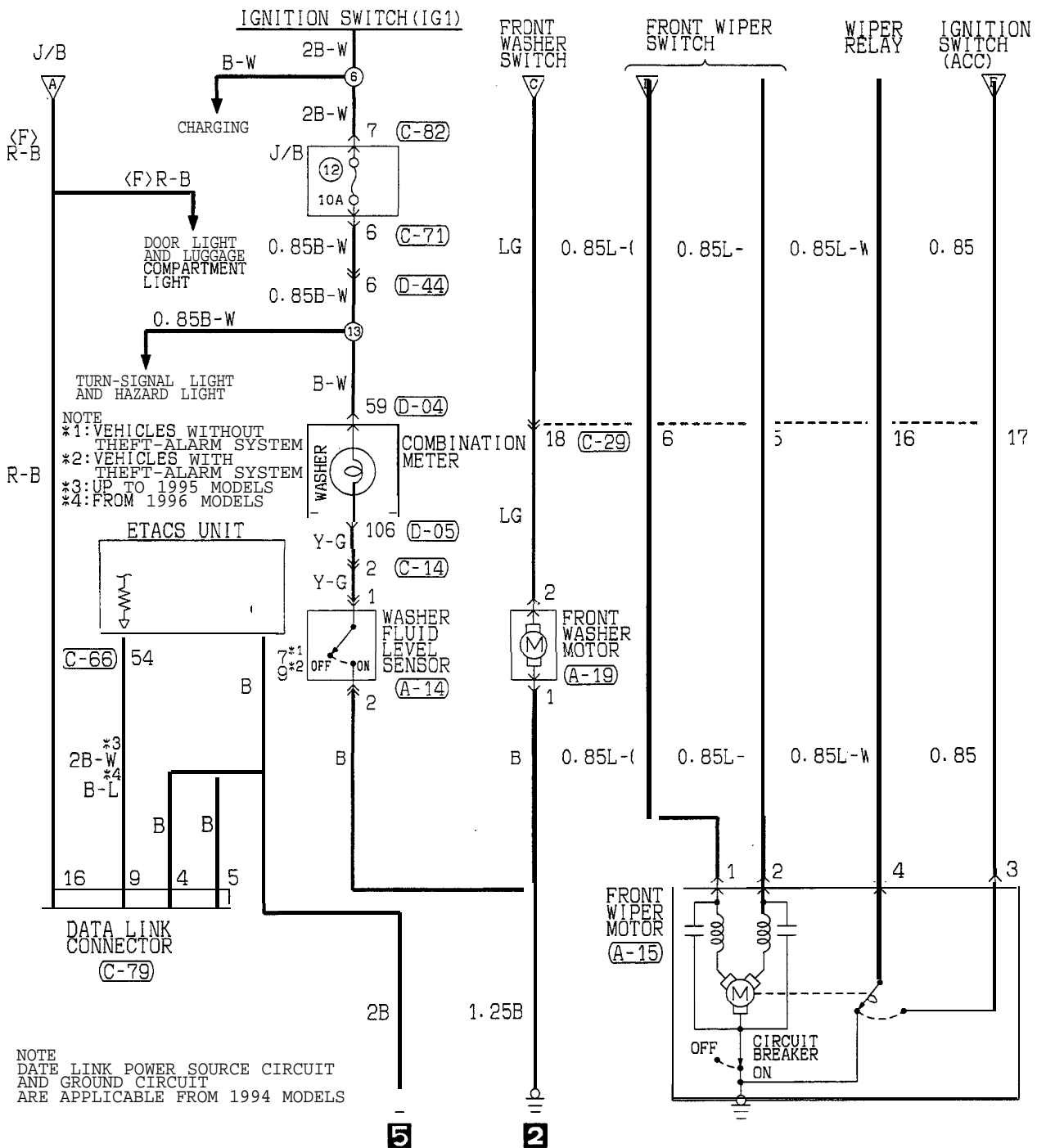

HR13M06AB

**TSB Revision**

REAR WIPER AND WASHER CIRCUIT

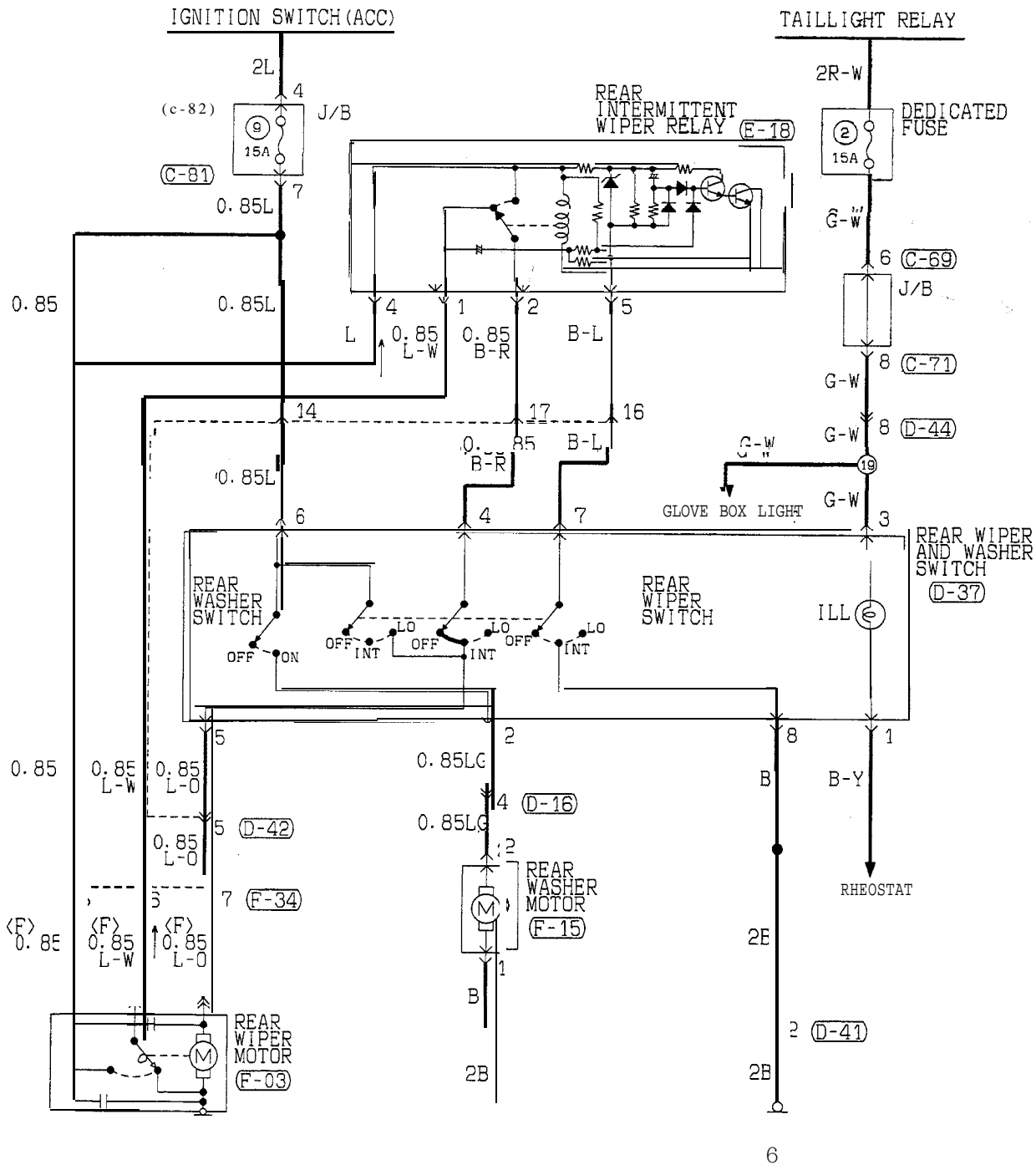

6

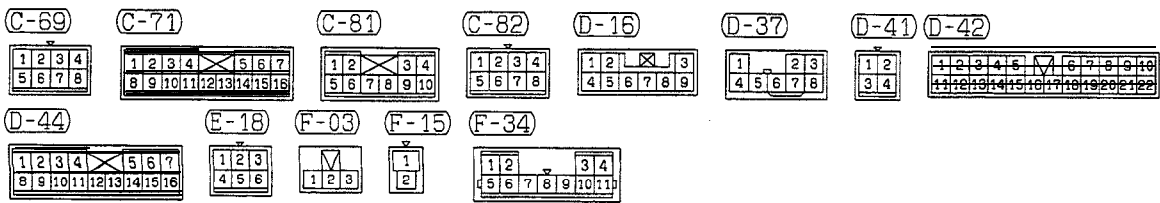

TSB Revision

COMPONENT LOCATION

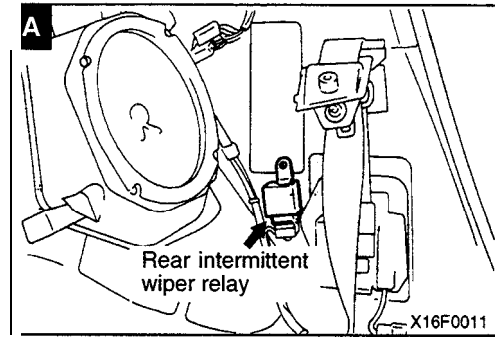
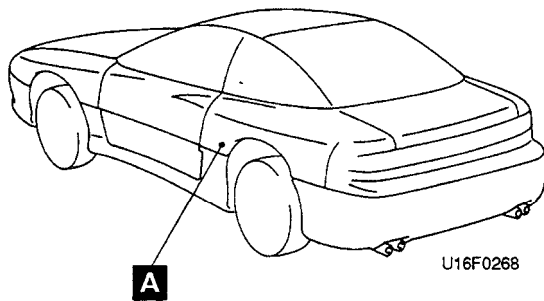

OPERATION

<Low-speed wiper>

- When the rear wiper switch is placed in the ON position with the ignition switch in the ACC or ON position, wipers operate continuously at low speed.

<Auto wiper stop>

- When the rear wiper switch is placed in the OFF position, the cam contains of wiper motor causes current to flow through the auto wiper stop circuit, allowing the wiper blades to cycle before they reach to the stop positions.

<Intermittent wiper>

- When the rear wiper switch is placed in the INT position with the ignition switch in ACC or ON position, the rear intermittent wiper relay is energized causing the rear intermittent wiper relay contacts to close and open repeatedly.
- When the contacts are closed, the wiper motor is energized.
- When the rear wiper motor is energized, the rear intermittent wiper relay contacts open; however, the cam contacts keep the rear wiper motor energized until the wiper blades return to their stop position.

TROUBLESHOOTING HINTS

1. Wipers do not operate.
  - (1) Washer is not operative, either.
    - Check multi-purpose fuse No. 9.
    - Check ground.
2. Low-speed wiper operation only is inoperative.
  - Check wiper switch.
3. Wipers do not stop.
  - Check wiper motor.
  - Check rear intermittent wiper relay.
  - Check rear wiper switch.
4. Intermittent wiper operation is inoperative.
  - Check terminal voltage of the rear intermittent wiper relay energized. (Refer to GROUP 51–Windshield Wiper and Washer for information concerning the installation position of the intermittent wiper relay.)

Terminal No.	Voltage	Check
2	0V	Rear intermittent wiper relay or rear wiper switch
	12V	Rear intermittent wiper relay
	0 ↔ 12V (alternating)	–(Normal)

5. Washer is inoperative.
  - Check washer motor.
  - Check washer switch.

REMOTE CONTROLLED MIRROR CIRCUIT

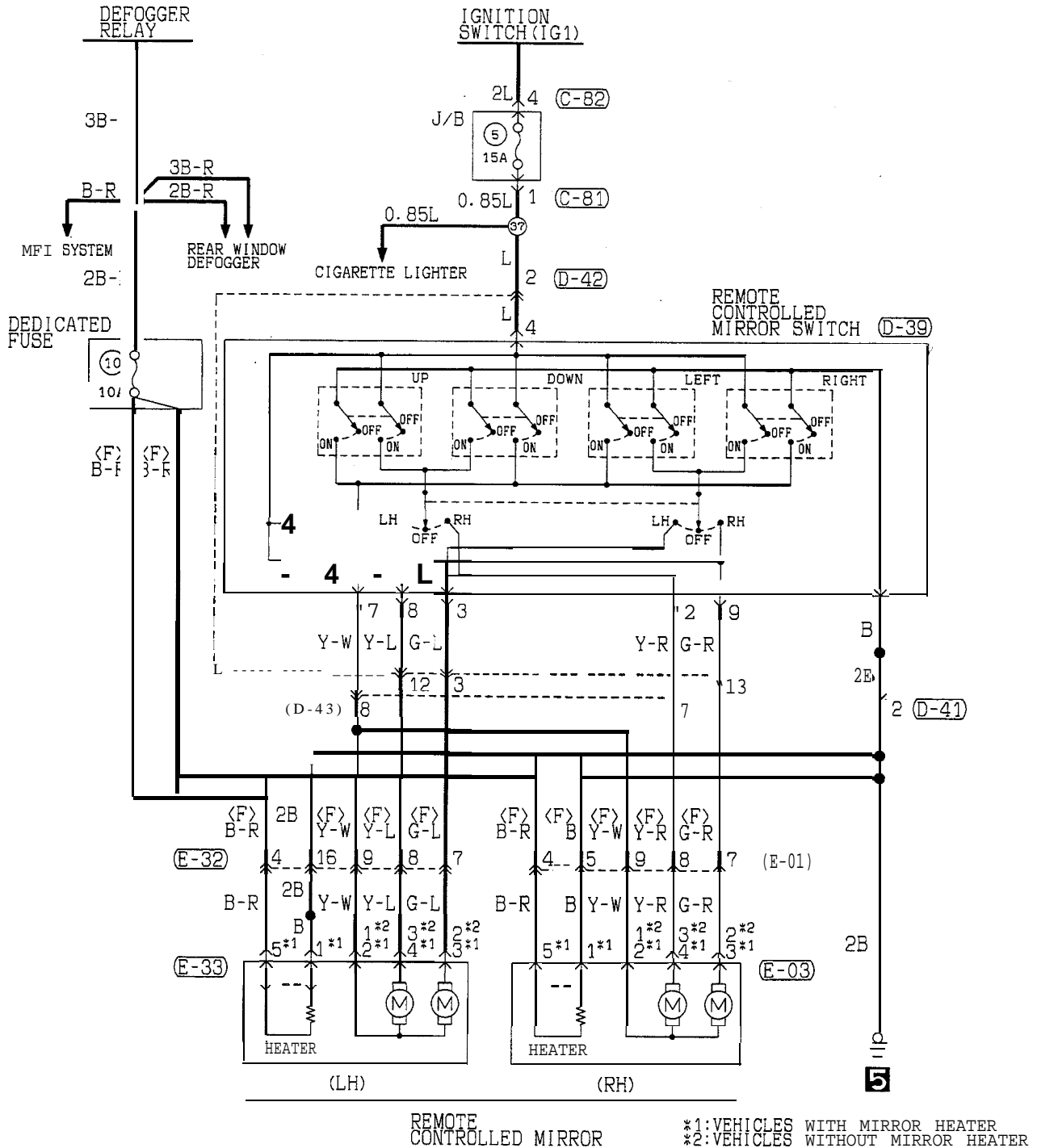

REMOTE CONTROLLED MIRROR

\*1: VEHICLES WITH MIRROR HEATER  
 \*2: VEHICLES WITHOUT MIRROR HEATER

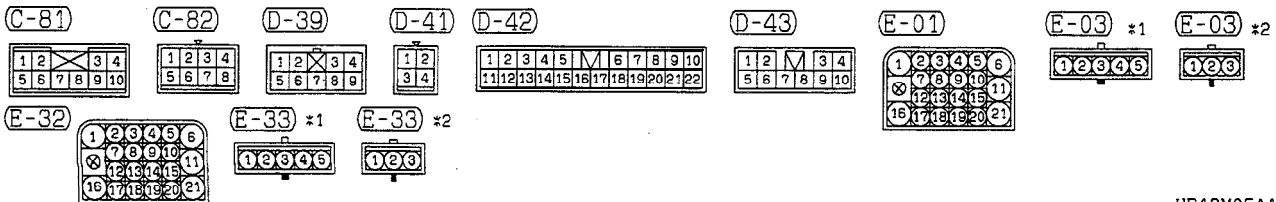

TSB Revision

**OPERATION**

- When the remote controlled mirror switch is operated while the ignition key is in “ACC” or “ON” position, current flows through fuse No. 5 remote controlled mirror switch, remote controlled mirror, remote controlled mirror switch, and ground, causing the mirror to move.

**TROUBLESHOOTING HINTS**

Neither right nor left mirror operates

- 1) Also cigarette lighter does not operate
  - Check multi-purpose fuse No. 5.
- 2) Cigarette lighter operates
  - Check remote controlled mirror switch.



# ANTI-LOCK BRAKING SYSTEM (ABS) CIRCUIT (UP TO OCTOBER, 1993)

<FWD>

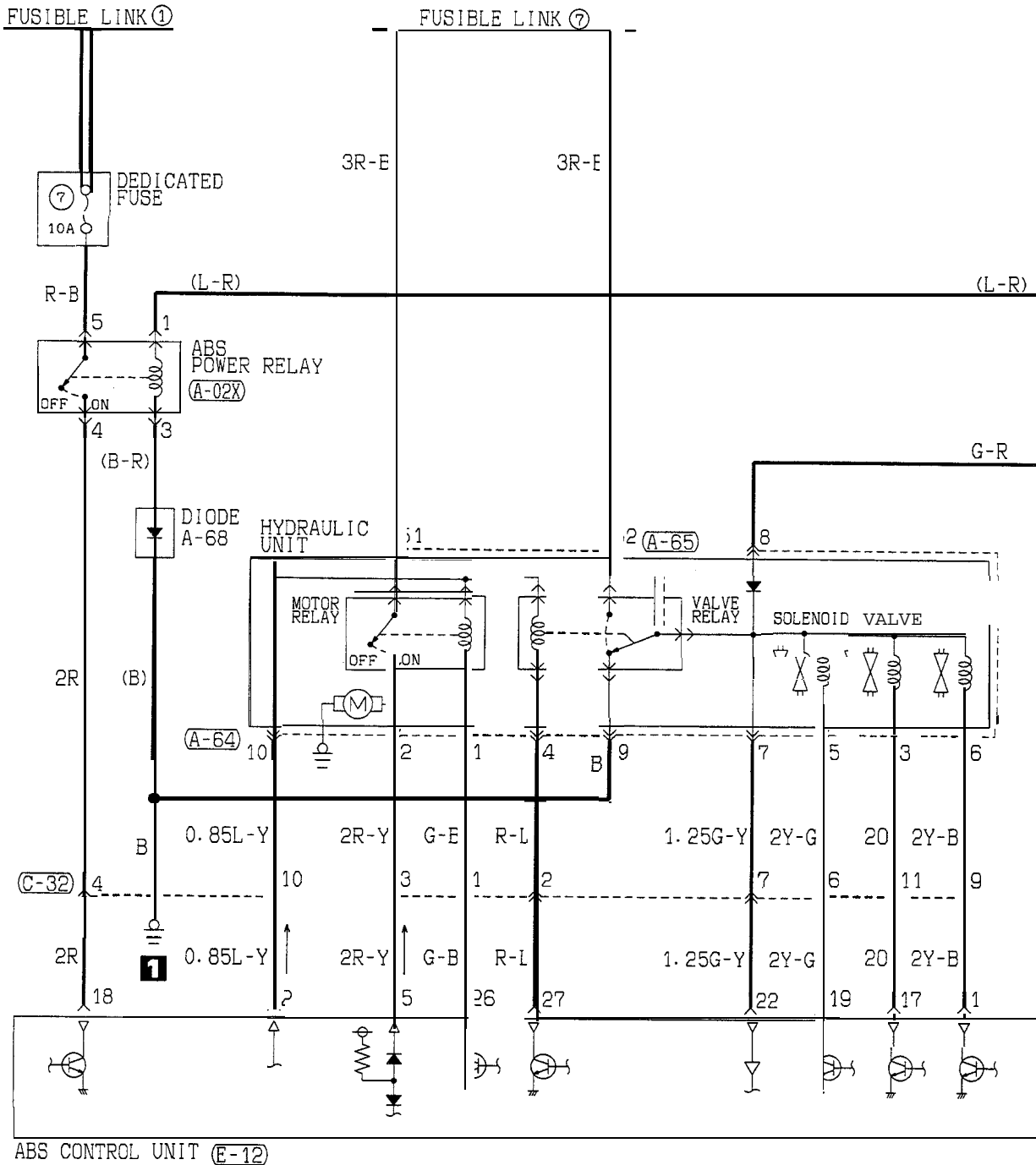

ABS CONTROL UNIT (E-12)

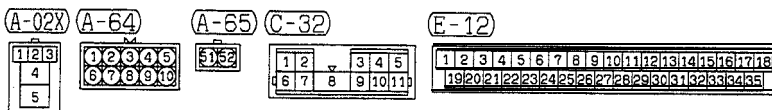

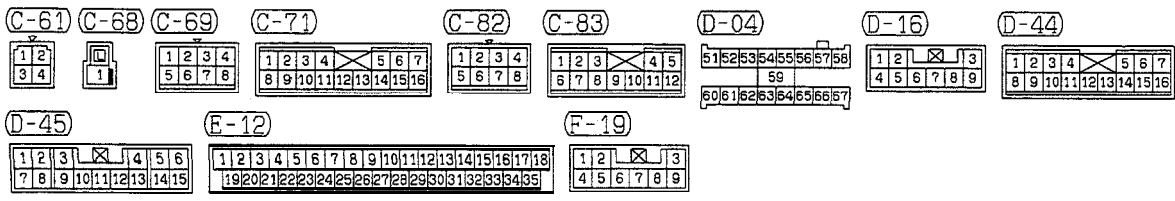
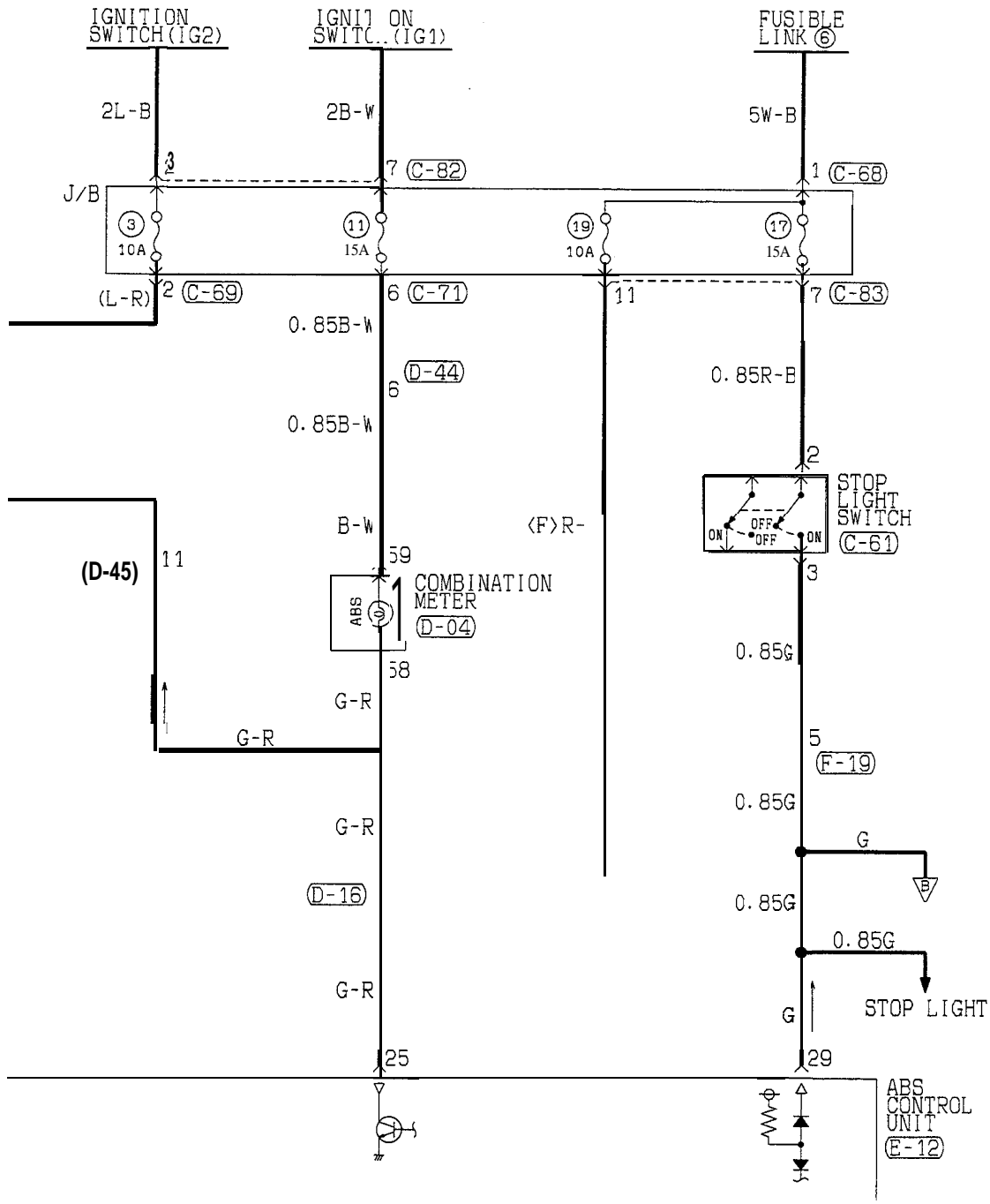

**TSB Revision**

ANTI-LOCK BRAKING SYSTEM (ABS) CIRCUIT (UP TO OCTOBER, 1993)  
<FWD> (CONTINUED)

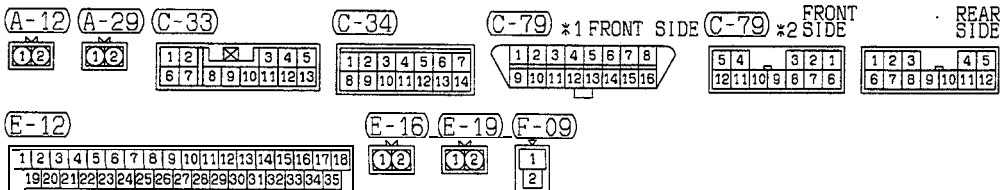
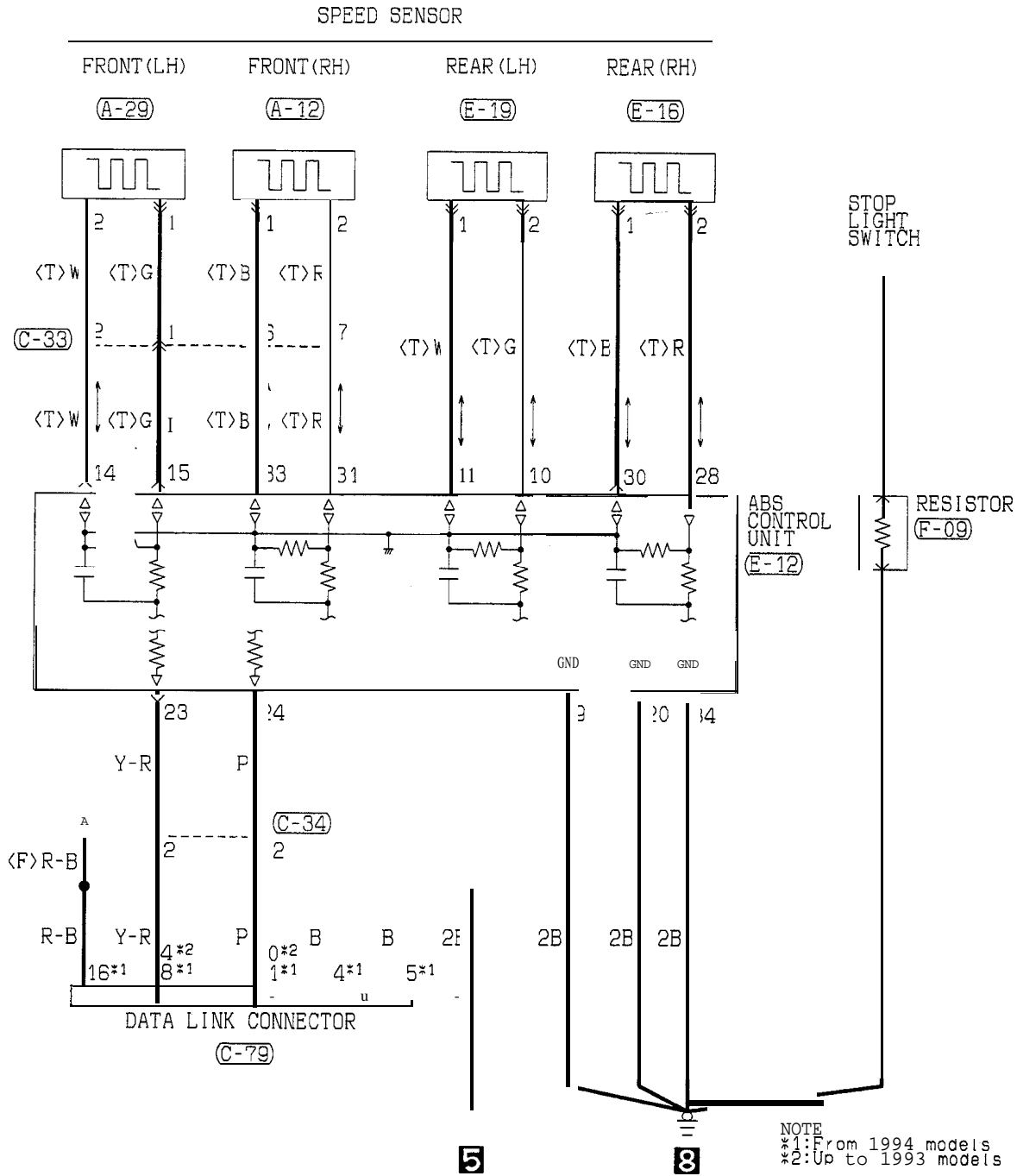

TSB Revision

---

NOTES

**ANTI-LOCK BRAKING SYSTEM (ABS) CIRCUIT**  
**(FROM NOVEMBER, 1993)**

<FWD> (HATCHBACK)

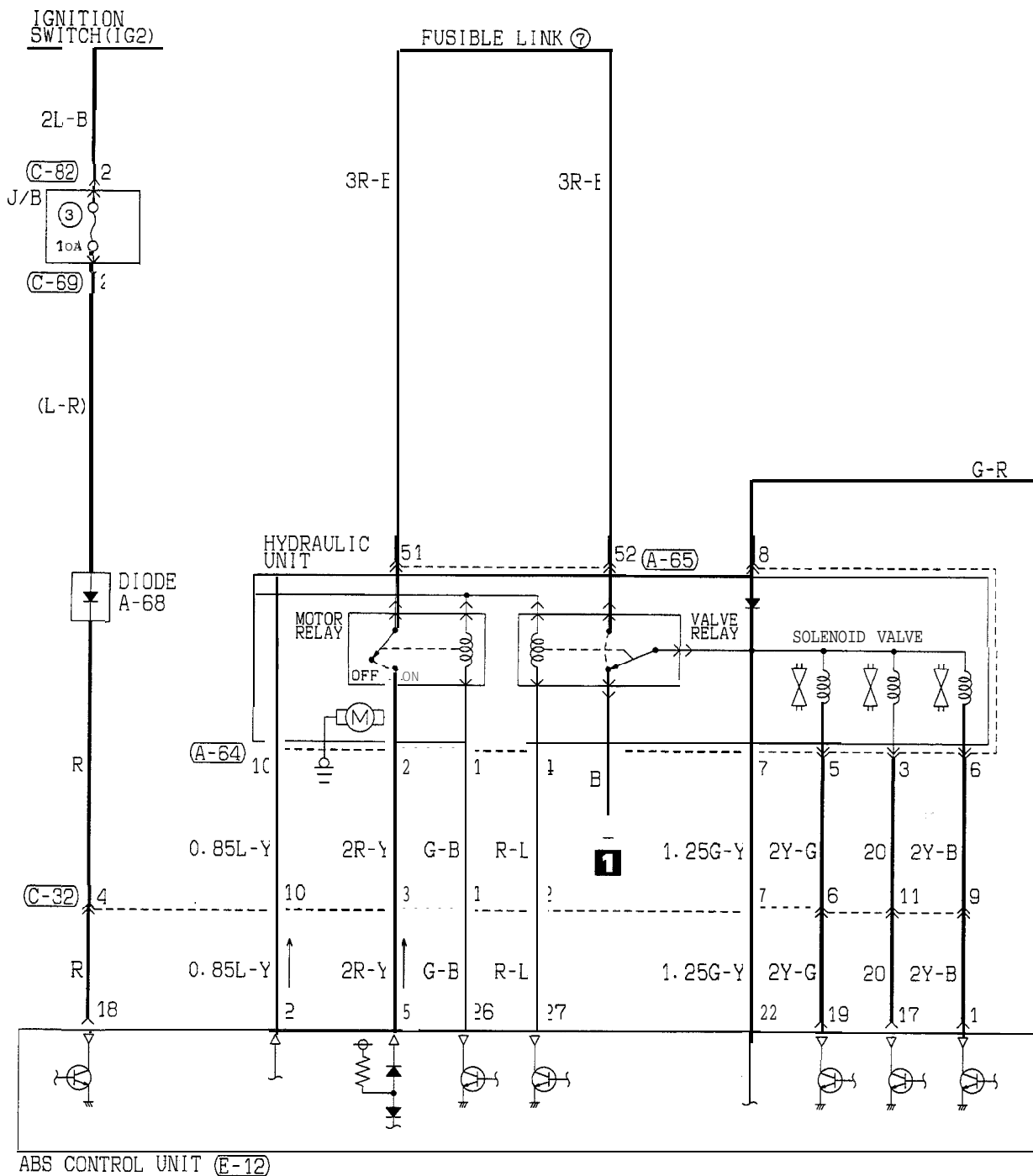

<b>A-64</b>	<b>A-65</b>	<b>C-32</b>	<b>C-69</b>	<b>C-82</b>	<b>E-12</b>
1 2 3 4 5 6 7 8 9 10	1 2	1 2 3 4 5 6 7 8 9 10 11	1 2 3 4 5 6 7 8	1 2 3 4 5 6 7 8	1 2 3 4 5 6 7 8 9 10 11 12 13 14 15 16 17 18 19 20 21 22 23 24 25 26 27 28 29 30 31 32 33 34 35

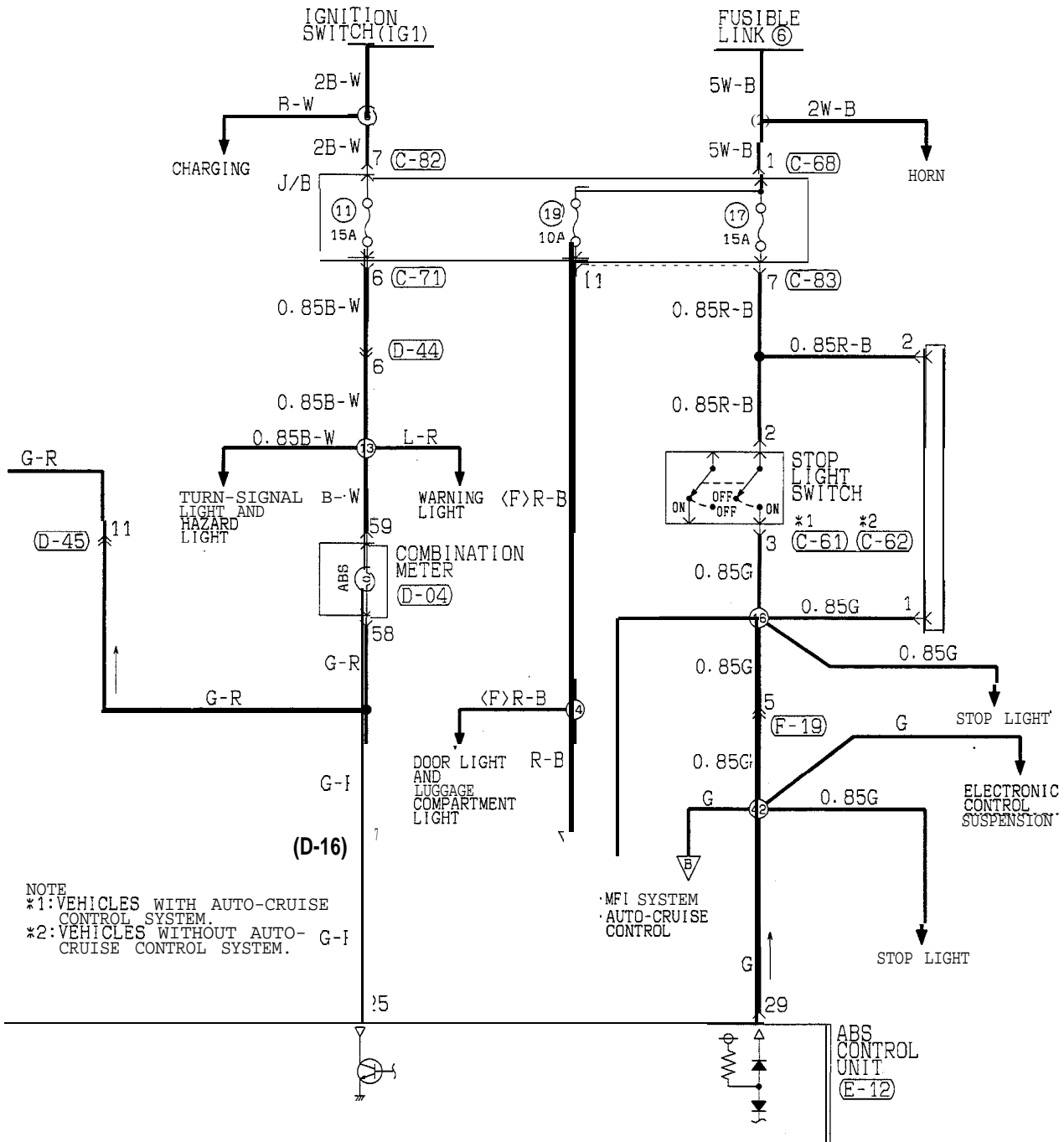

NOTE  
 \*1: VEHICLES WITH AUTO-CRUISE CONTROL SYSTEM.  
 \*2: VEHICLES WITHOUT AUTO-CRUISE CONTROL SYSTEM.

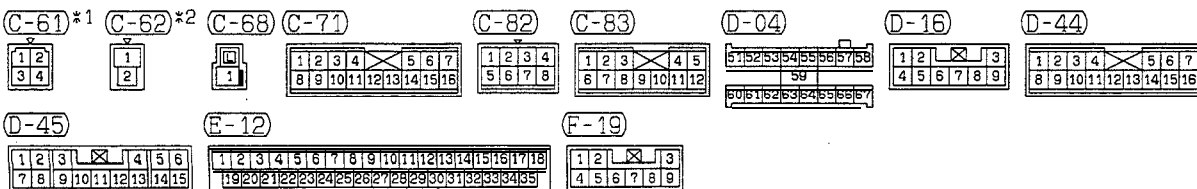

**TSB Revision**

ANTI-LOCK BRAKING SYSTEM (ABS) CIRCUIT (FROM NOVEMBER, 1993)  
<FWD> (HATCHBACK) (CONTINUED)

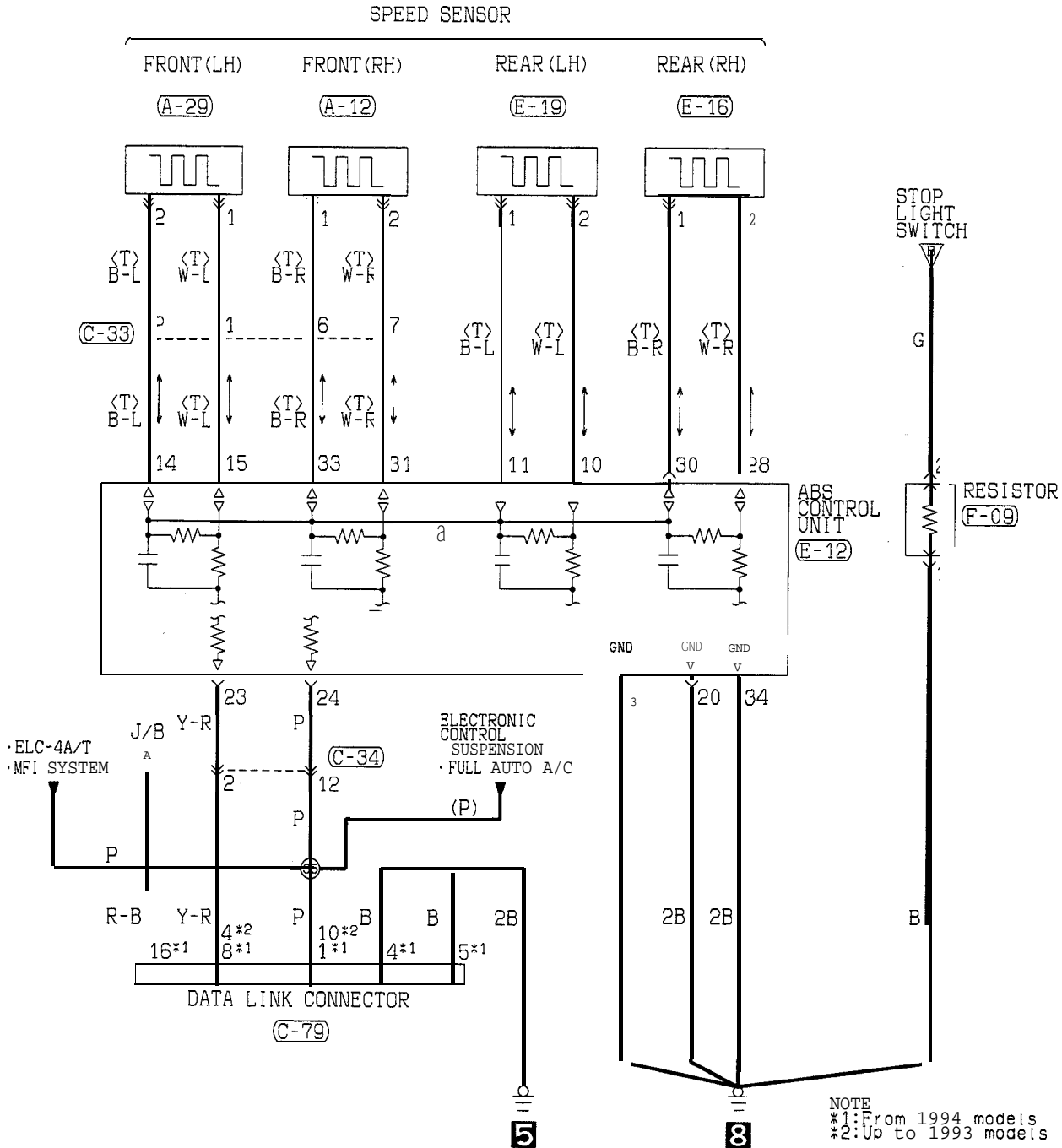

NOTE  
\*1: From 1994 models  
\*2: Up to 1993 models

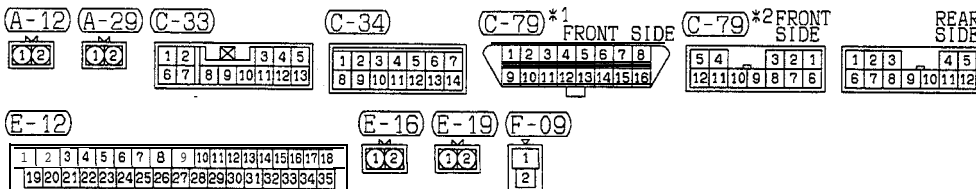

TSB Revision

---

NOTES



**ANTI-LOCK BRAKING SYSTEM (ABS) CIRCUIT   
 (1995 MODELS)**

<FWD> (CONVERTIBLE)

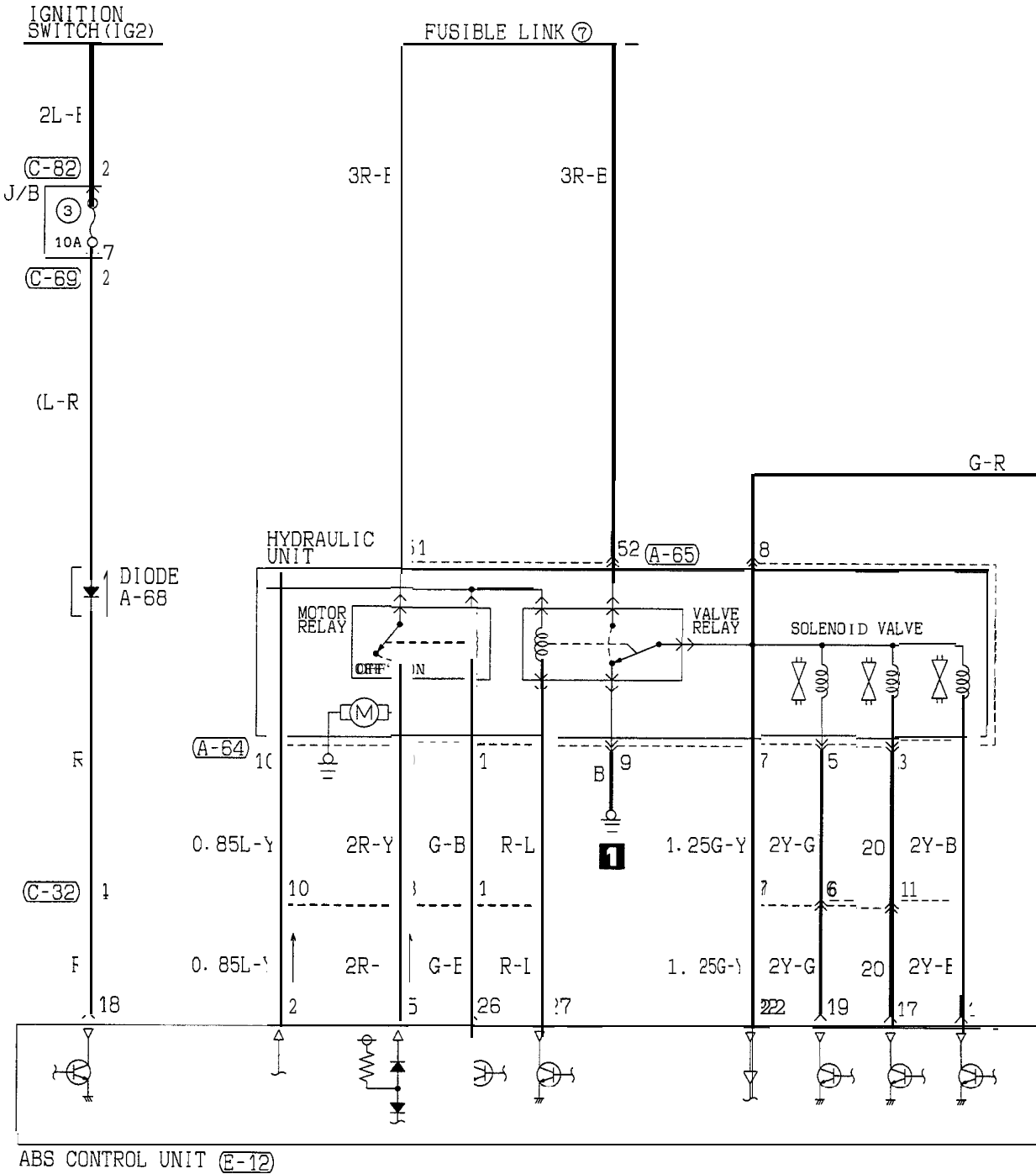

<b>A-64</b>	<b>A-65</b>	<b>C-32</b>	<b>C-69</b>	<b>C-82</b>	<b>E-12</b>																																																																
<table border="1"> <tr><td>1</td><td>2</td><td>3</td><td>4</td><td>5</td></tr> <tr><td>6</td><td>7</td><td>8</td><td>9</td><td>10</td></tr> </table>	1	2	3	4	5	6	7	8	9	10	<table border="1"> <tr><td>1</td><td>2</td></tr> </table>	1	2	<table border="1"> <tr><td>1</td><td>2</td><td>3</td><td>4</td><td>5</td></tr> <tr><td>6</td><td>7</td><td>8</td><td>9</td><td>10</td></tr> </table>	1	2	3	4	5	6	7	8	9	10	<table border="1"> <tr><td>1</td><td>2</td><td>3</td><td>4</td></tr> <tr><td>5</td><td>6</td><td>7</td><td>8</td></tr> </table>	1	2	3	4	5	6	7	8	<table border="1"> <tr><td>1</td><td>2</td><td>3</td><td>4</td><td>5</td><td>6</td><td>7</td><td>8</td><td>9</td><td>10</td><td>11</td><td>12</td><td>13</td><td>14</td><td>15</td><td>16</td><td>17</td><td>18</td></tr> <tr><td>19</td><td>20</td><td>21</td><td>22</td><td>23</td><td>24</td><td>25</td><td>26</td><td>27</td><td>28</td><td>29</td><td>30</td><td>31</td><td>32</td><td>33</td><td>34</td><td>35</td></tr> </table>	1	2	3	4	5	6	7	8	9	10	11	12	13	14	15	16	17	18	19	20	21	22	23	24	25	26	27	28	29	30	31	32	33	34	35
1	2	3	4	5																																																																	
6	7	8	9	10																																																																	
1	2																																																																				
1	2	3	4	5																																																																	
6	7	8	9	10																																																																	
1	2	3	4																																																																		
5	6	7	8																																																																		
1	2	3	4	5	6	7	8	9	10	11	12	13	14	15	16	17	18																																																				
19	20	21	22	23	24	25	26	27	28	29	30	31	32	33	34	35																																																					

TSB Revision

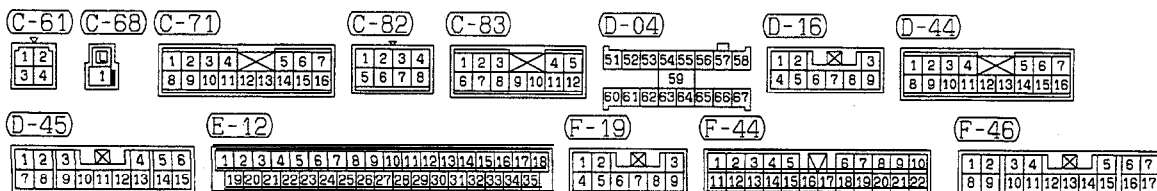
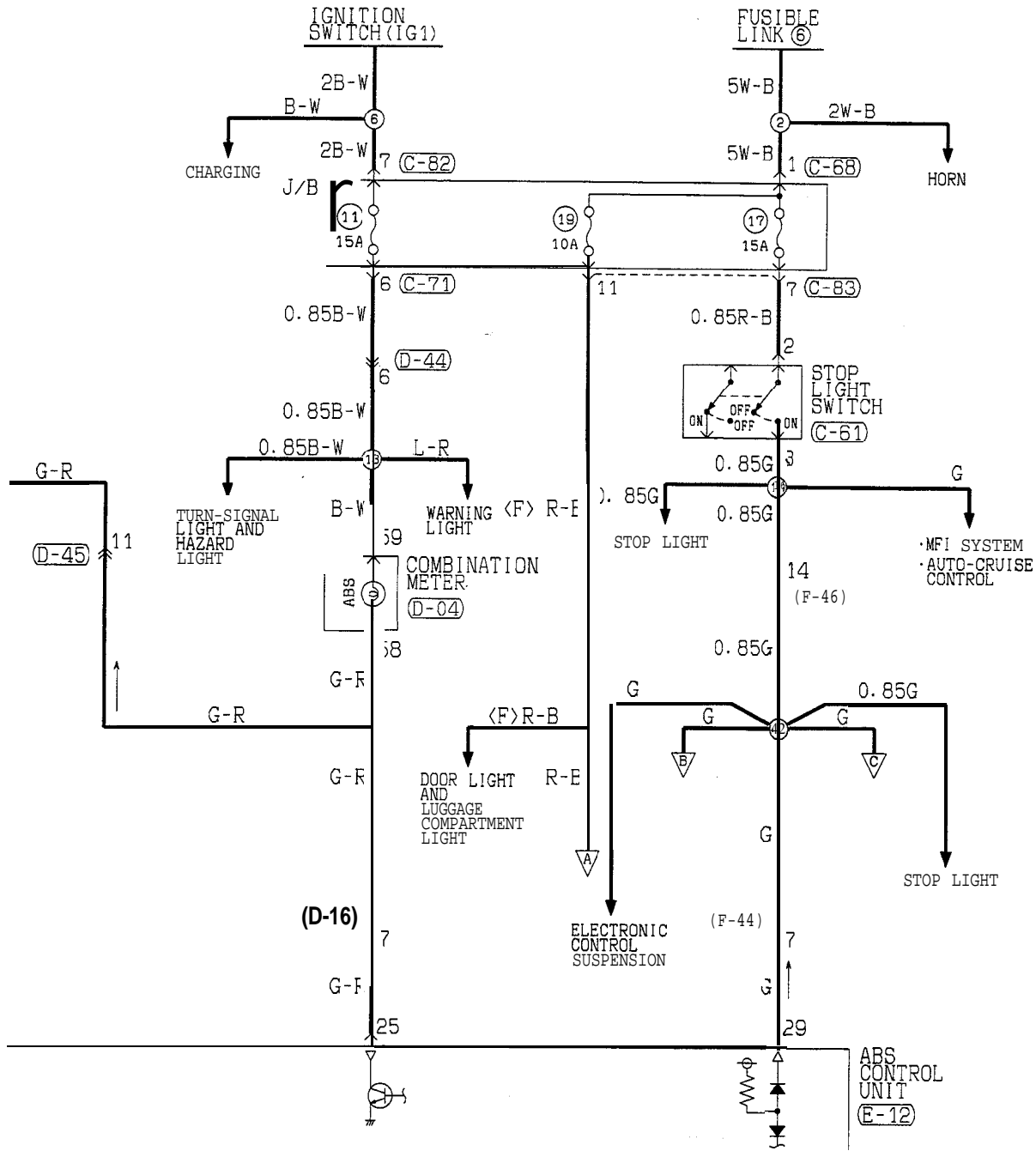

TSB Revision

ANTI-LOCK BRAKING SYSTEM (ABS) CIRCUIT (1995 MODELS)  
<FWD> (CONVERTIBLE) (CONTINUED)

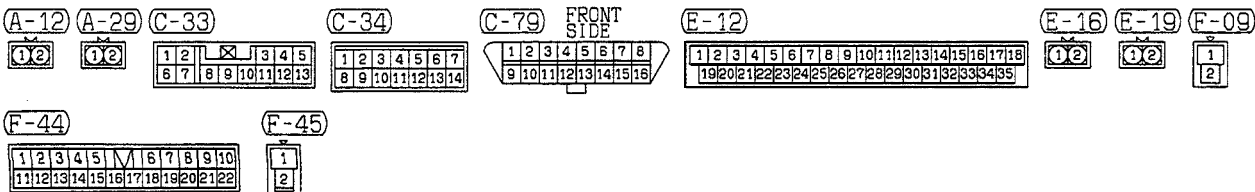
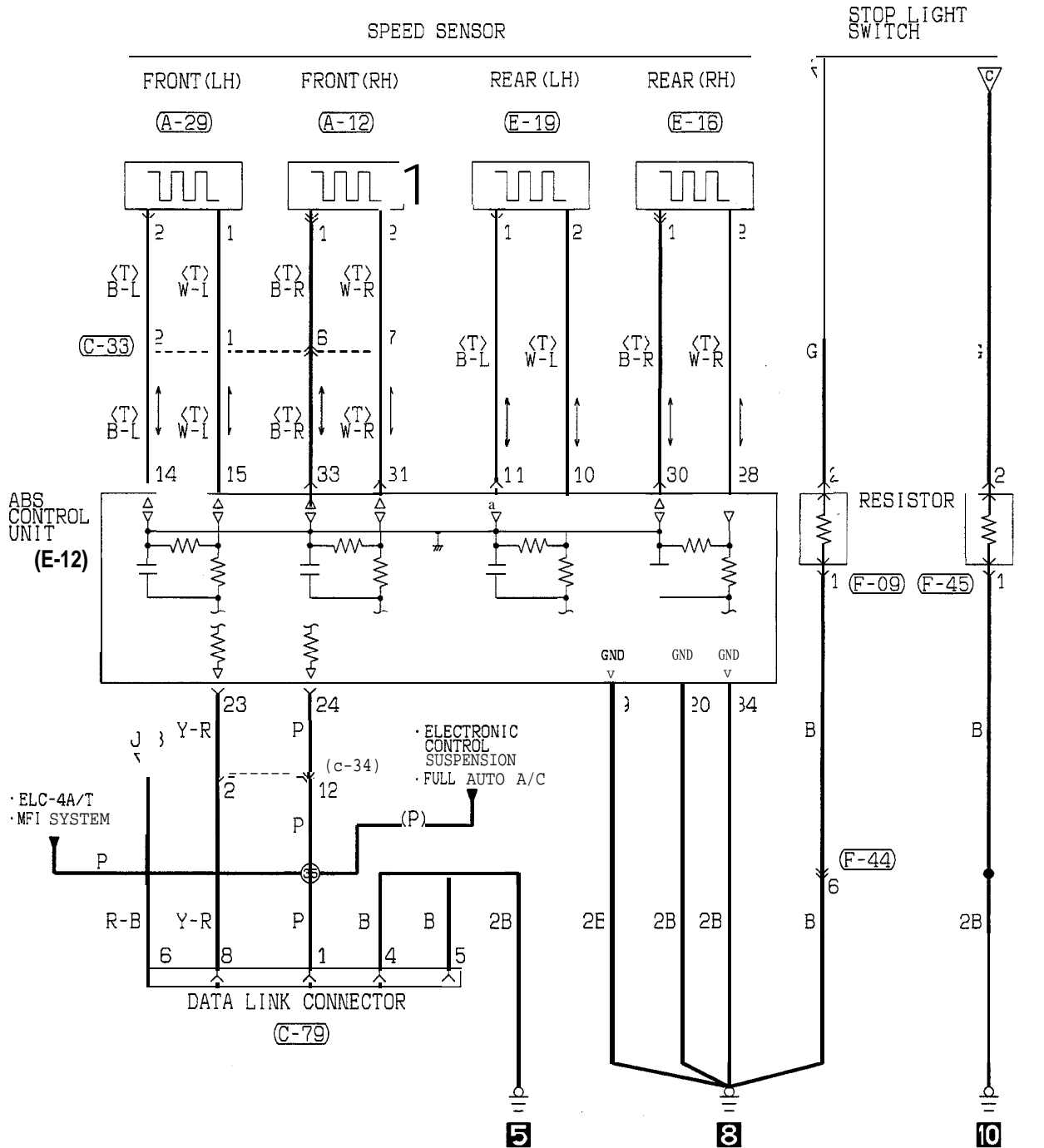

---

NOTES

ANTI-LOCK BRAKING SYSTEM (ABS) CIRCUIT  
(UP TO OCTOBER, 1993)

<AWD>

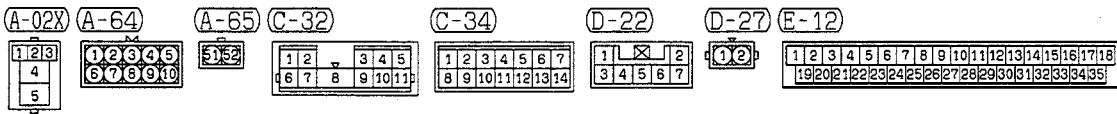
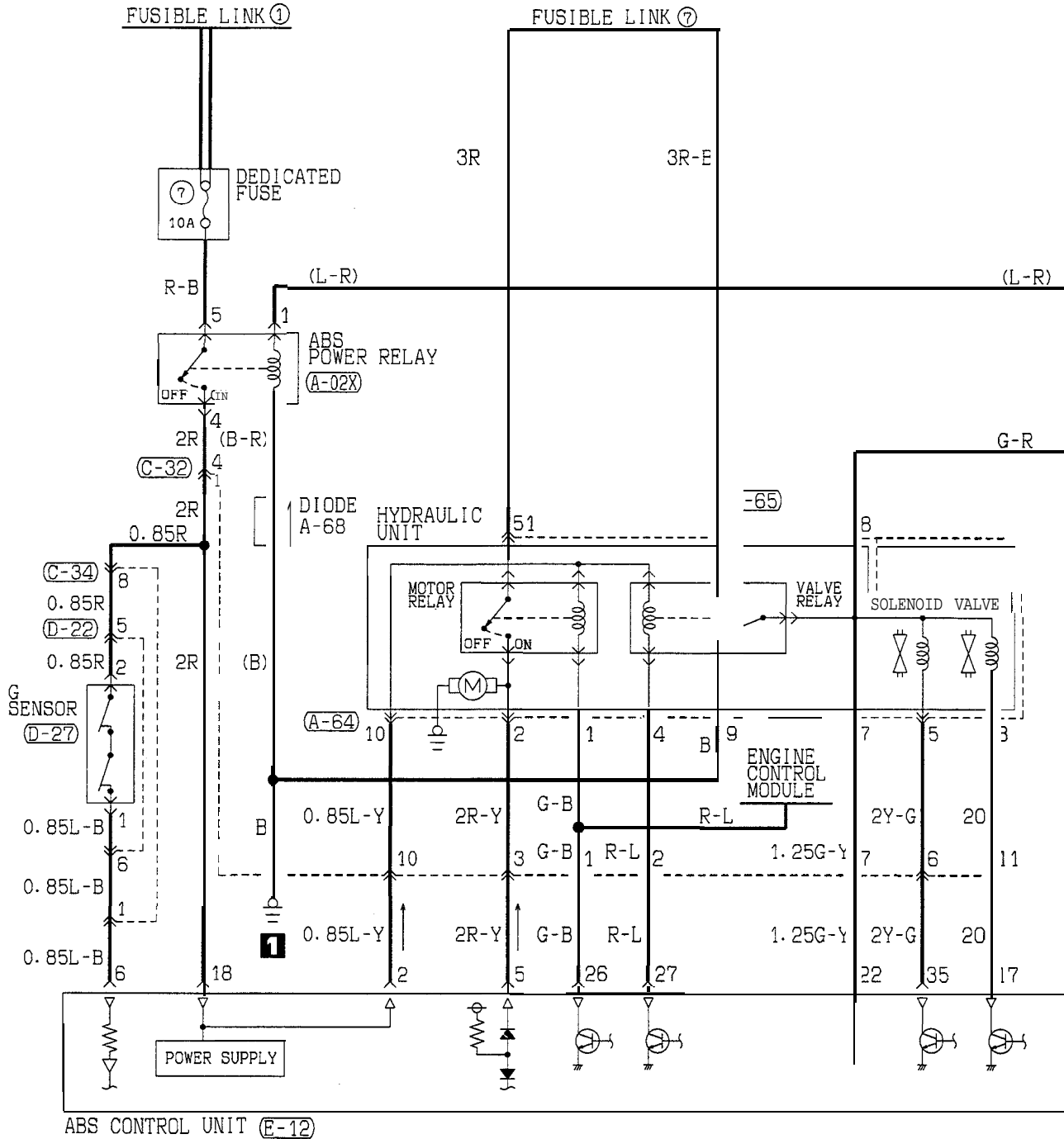

TSB Revision

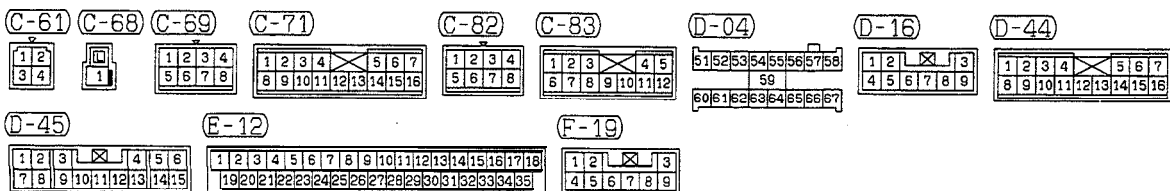
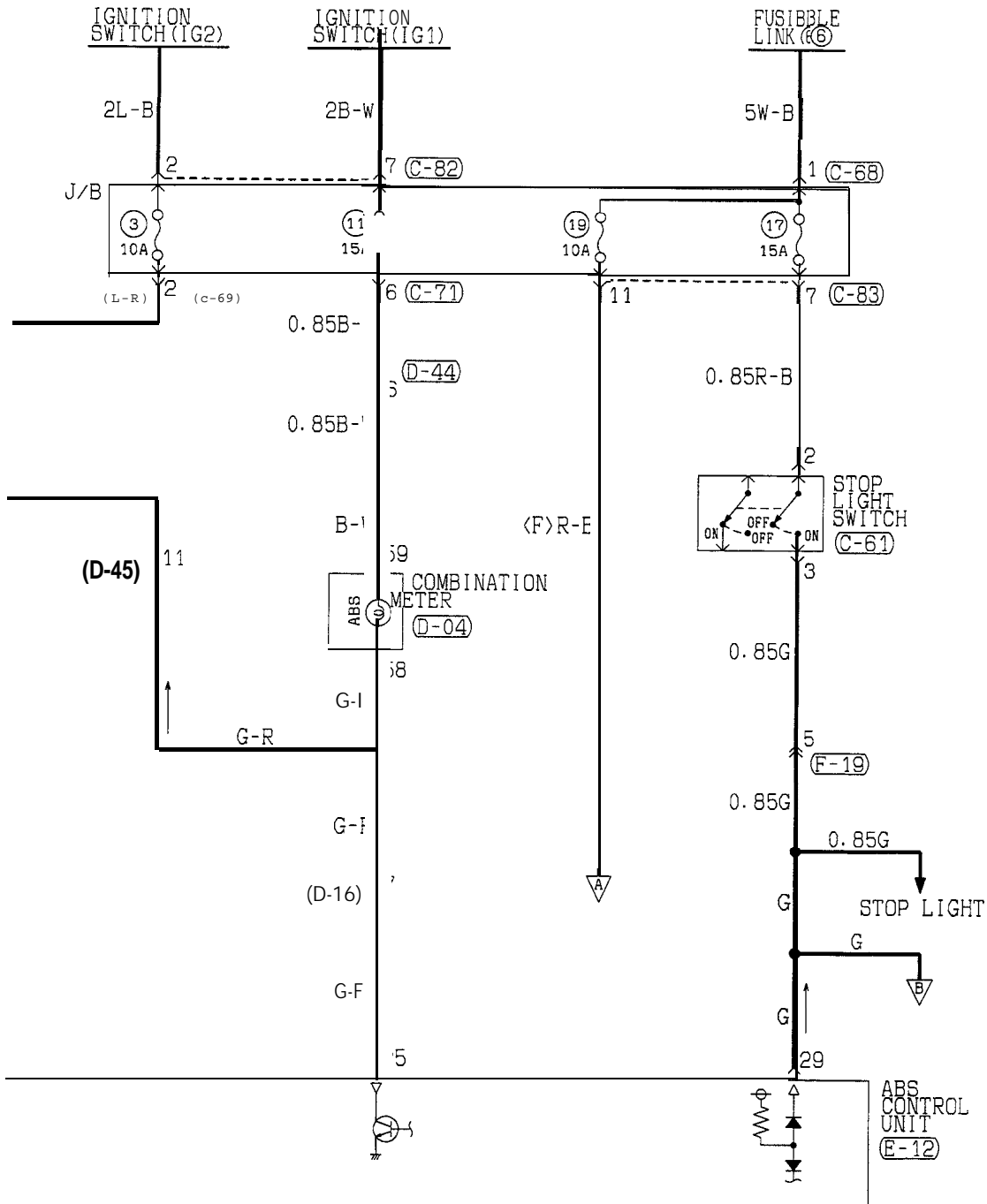

**TSB Revision**

ANTI-LOCK BRAKING SYSTEM (ABS) CIRCUIT (UP TO OCTOBER, 1993)  
<AWD> (CONTINUED)

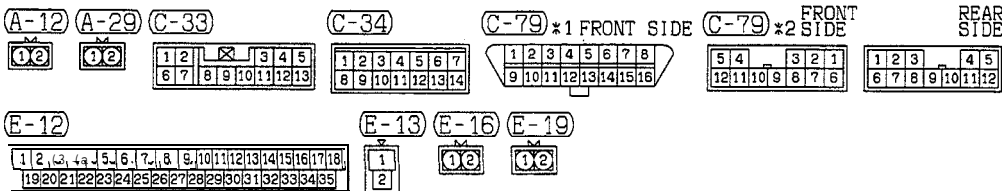
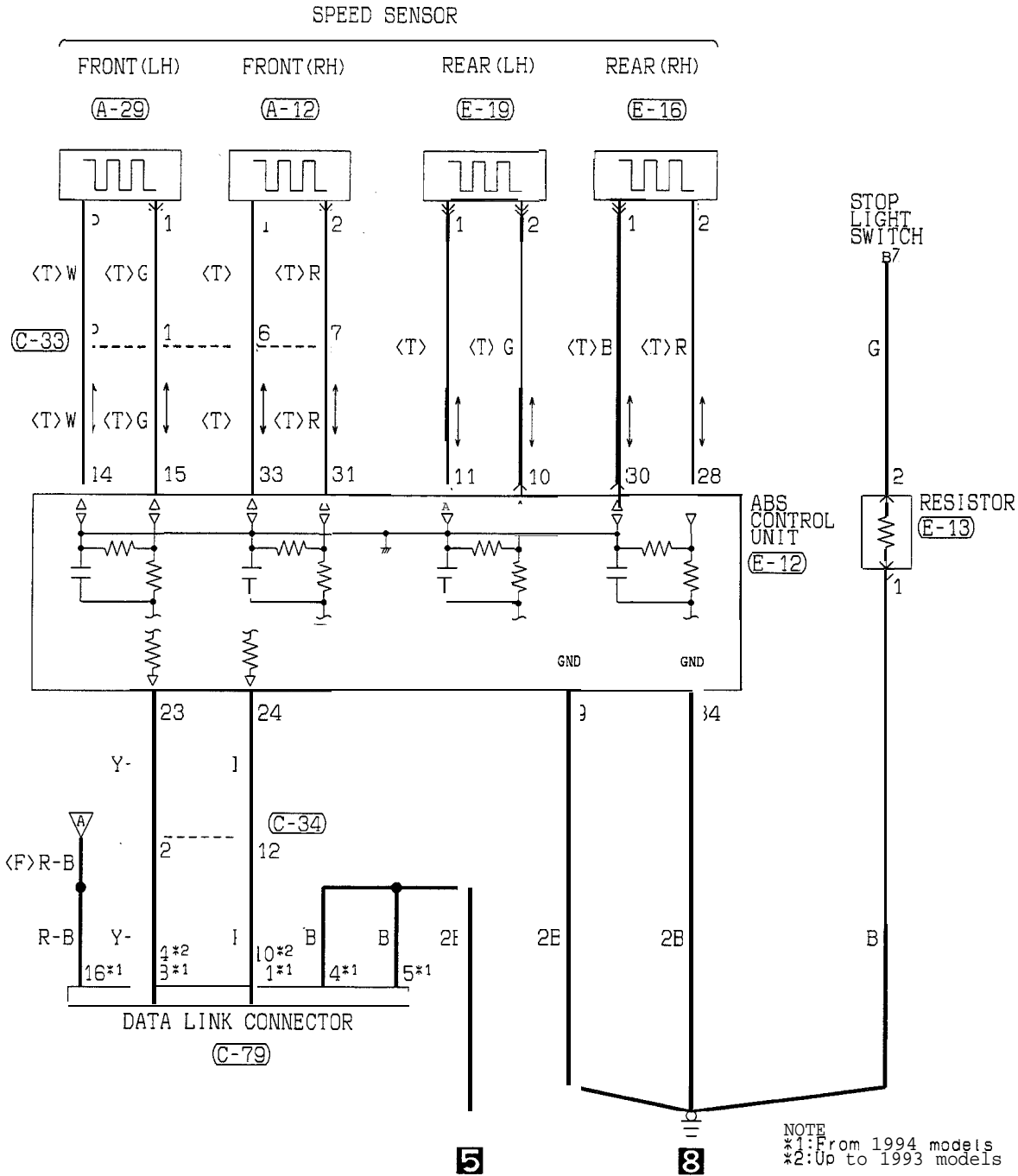

---

NOTES



# ANTI-LOCK BRAKING SYSTEM (ABS) CIRCUIT (FROM NOVEMBER, 1993)

<AWD> (HATCHBACK)

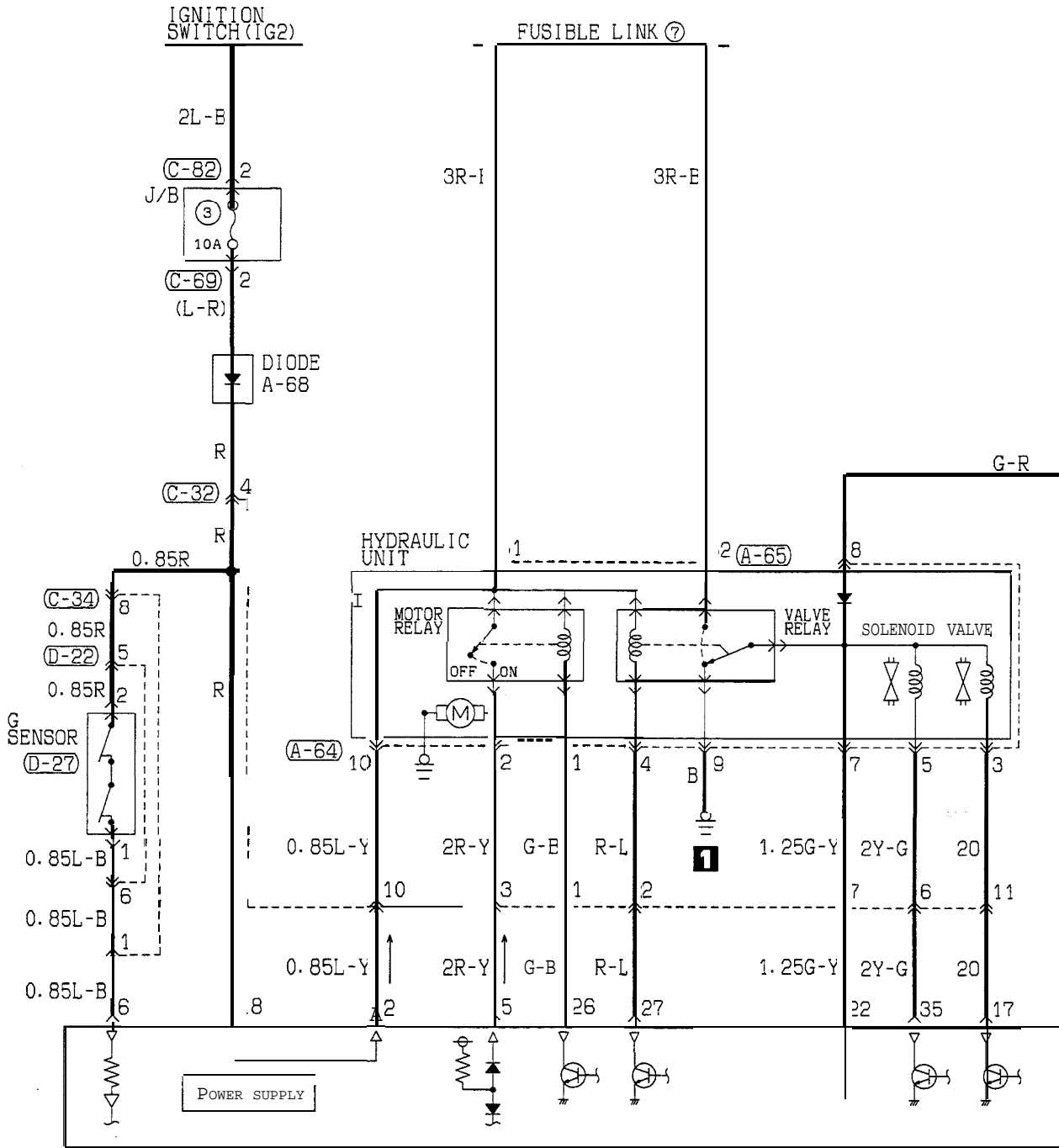

A-64	A-65	C-32	C-34	C-69	C-82	D-22	D-27	E-12
1 2 3 4 5 6 7 8 9 10	1 2 3	1 2 3 4 5 6 7 8 9 10 11	1 2 3 4 5 6 7 8 9 10 11 12 13 14	1 2 3 4 5 6 7 8	1 2 3 4 5 6 7 8	1 2 3 4 5 6 7	1 2	1 2 3 4 5 6 7 8 9 10 11 12 13 14 15 16 17 18 19 20 21 22 23 24 25 26 27 28 29 30 31 32 33 34 35

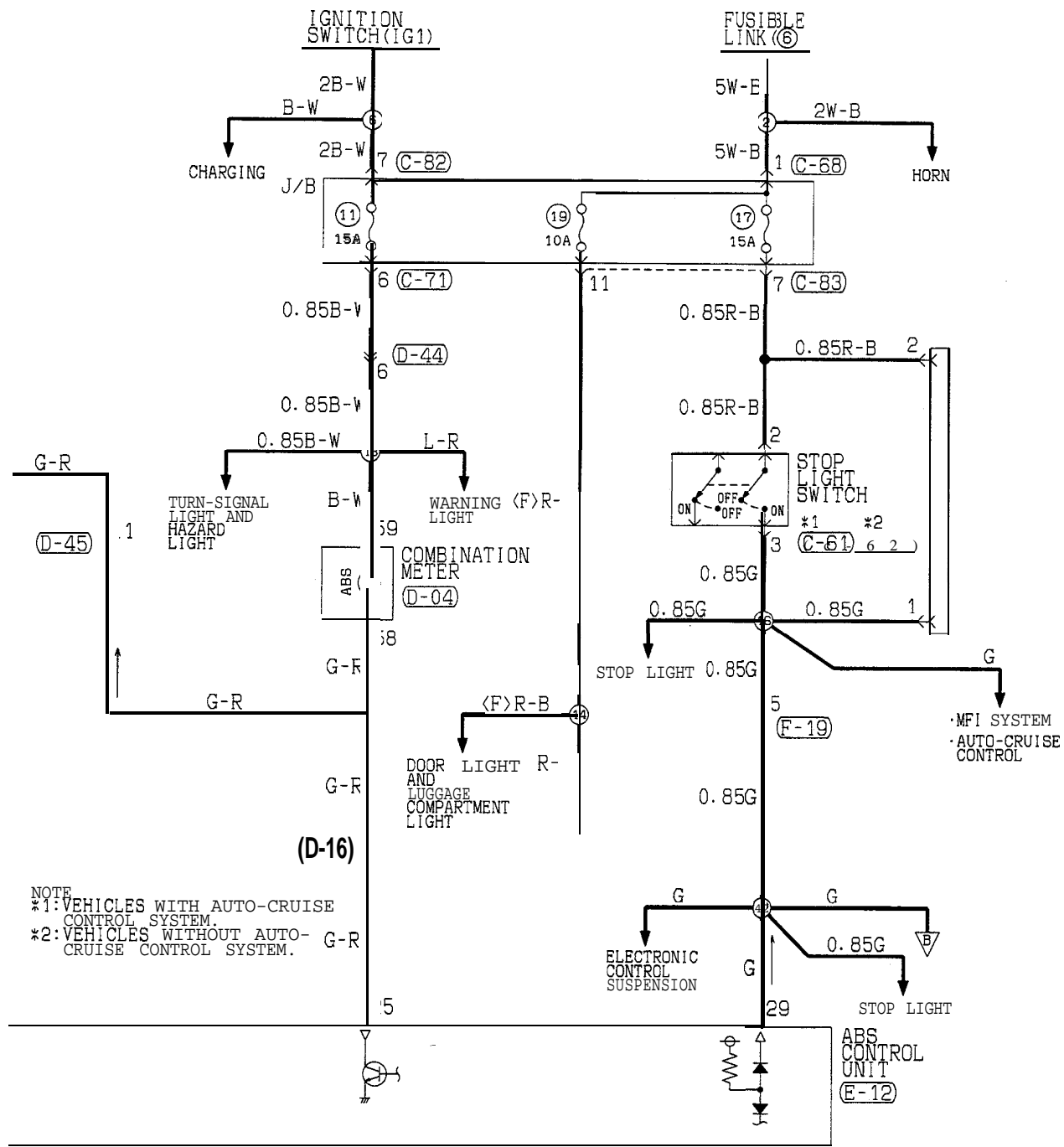

NOTE  
 \*1: VEHICLES WITH AUTO-CRUISE CONTROL SYSTEM.  
 \*2: VEHICLES WITHOUT AUTO-CRUISE CONTROL SYSTEM.

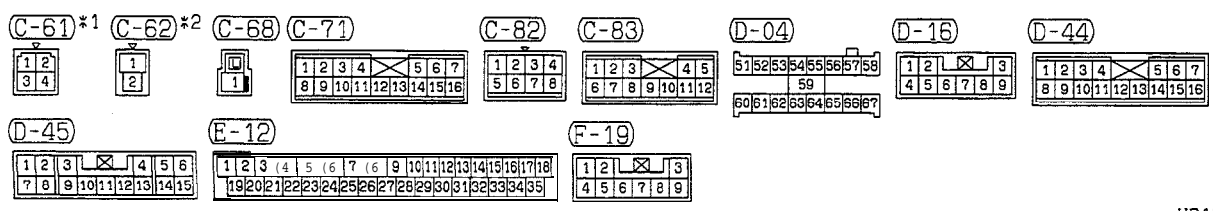

**TSB Revision**

ANTI-LOCK BRAKING SYSTEM (ABS) CIRCUIT (FROM NOVEMBER, 1993)  
<AWD> (HATCHBACK) (CONTINUED)

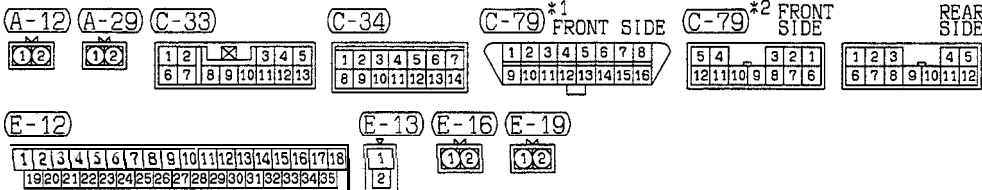
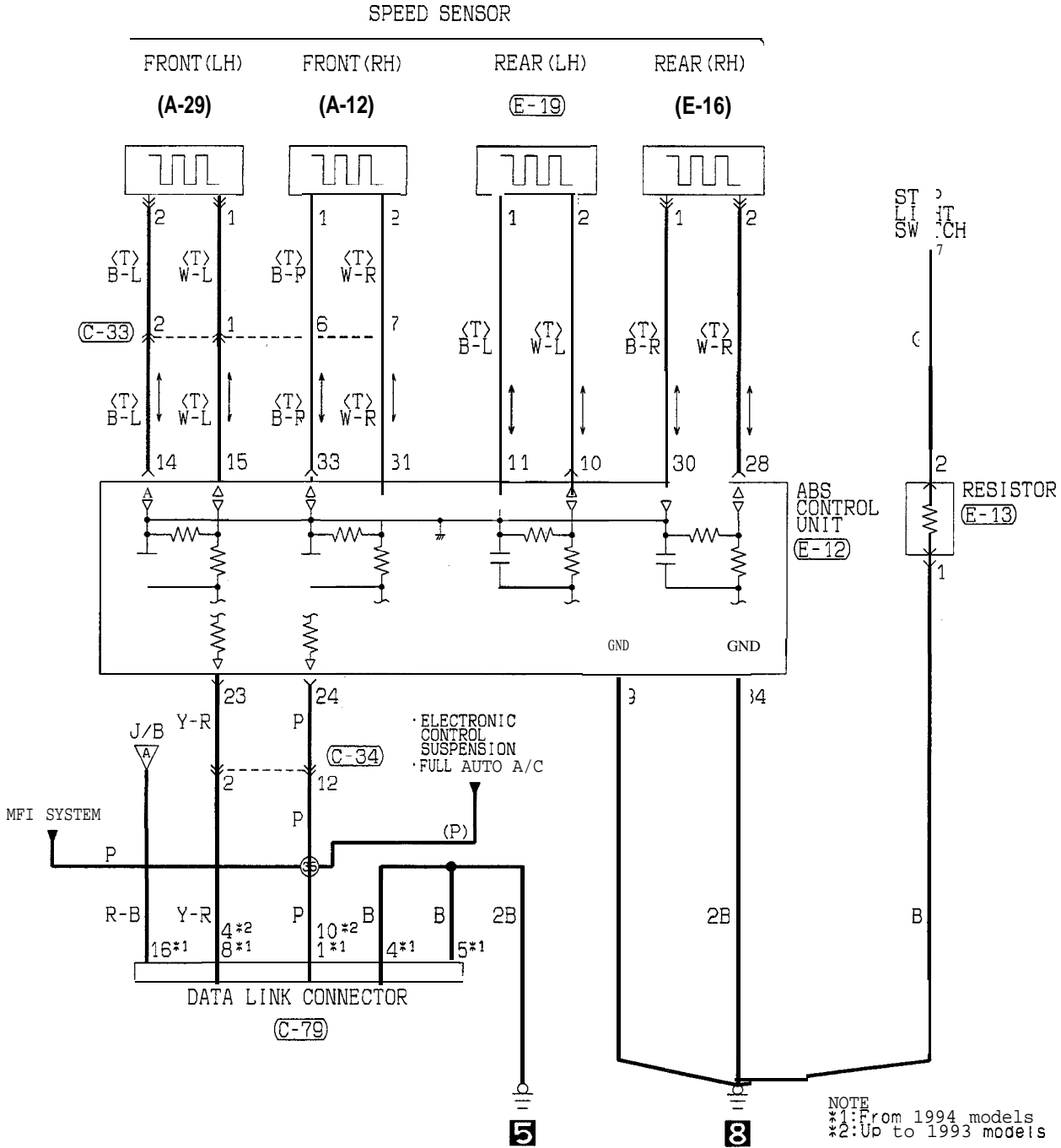

---

NOTES

# ANTI-LOCK BRAKING SYSTEM (ABS) CIRCUIT (1995 MODELS)

<AWD> (CONVERTIBLE)

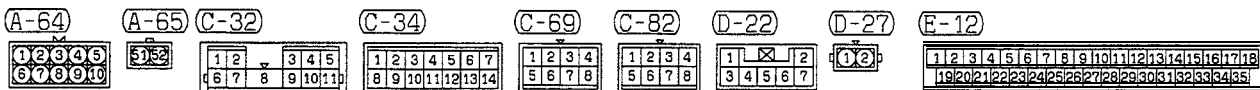
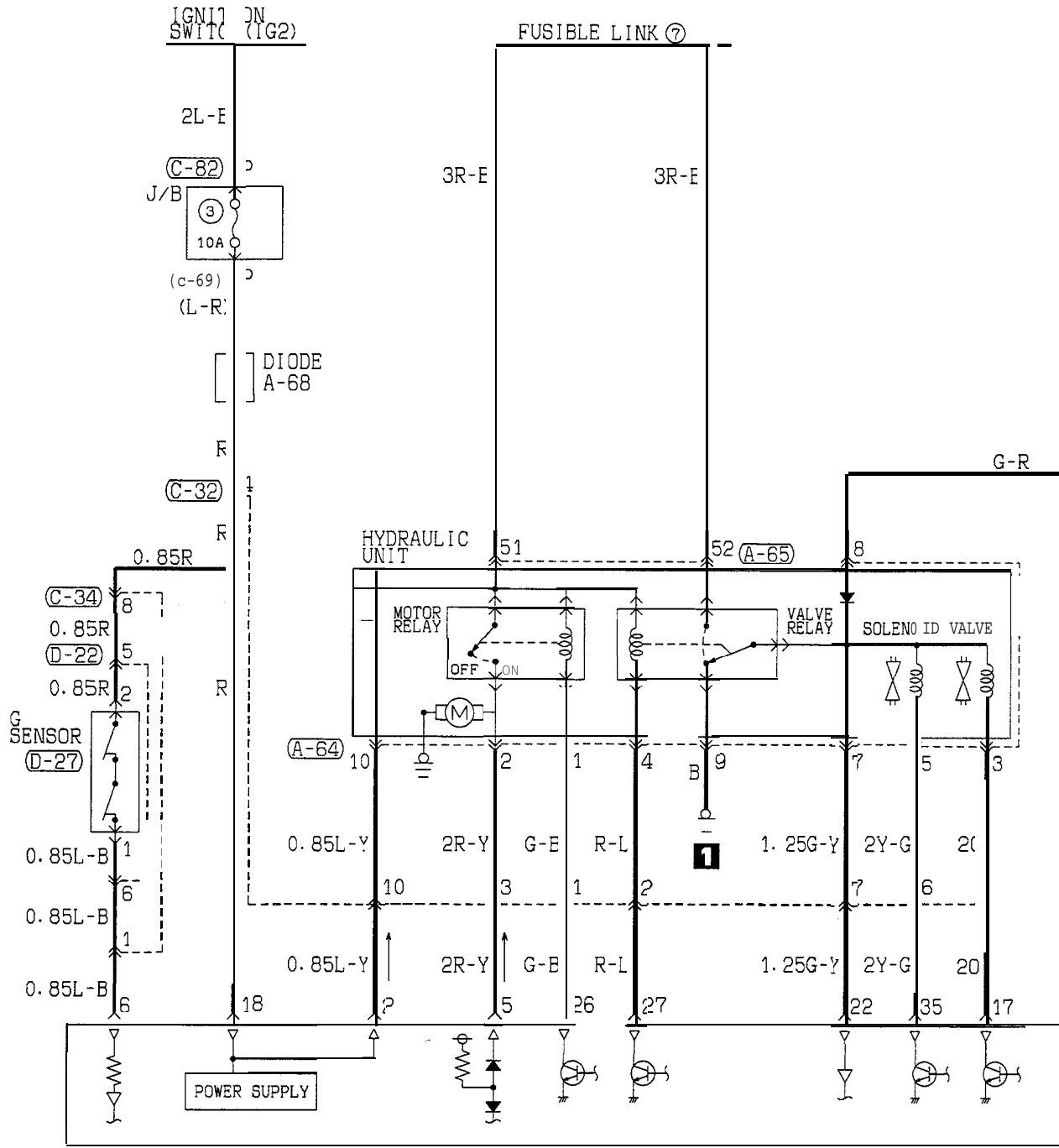

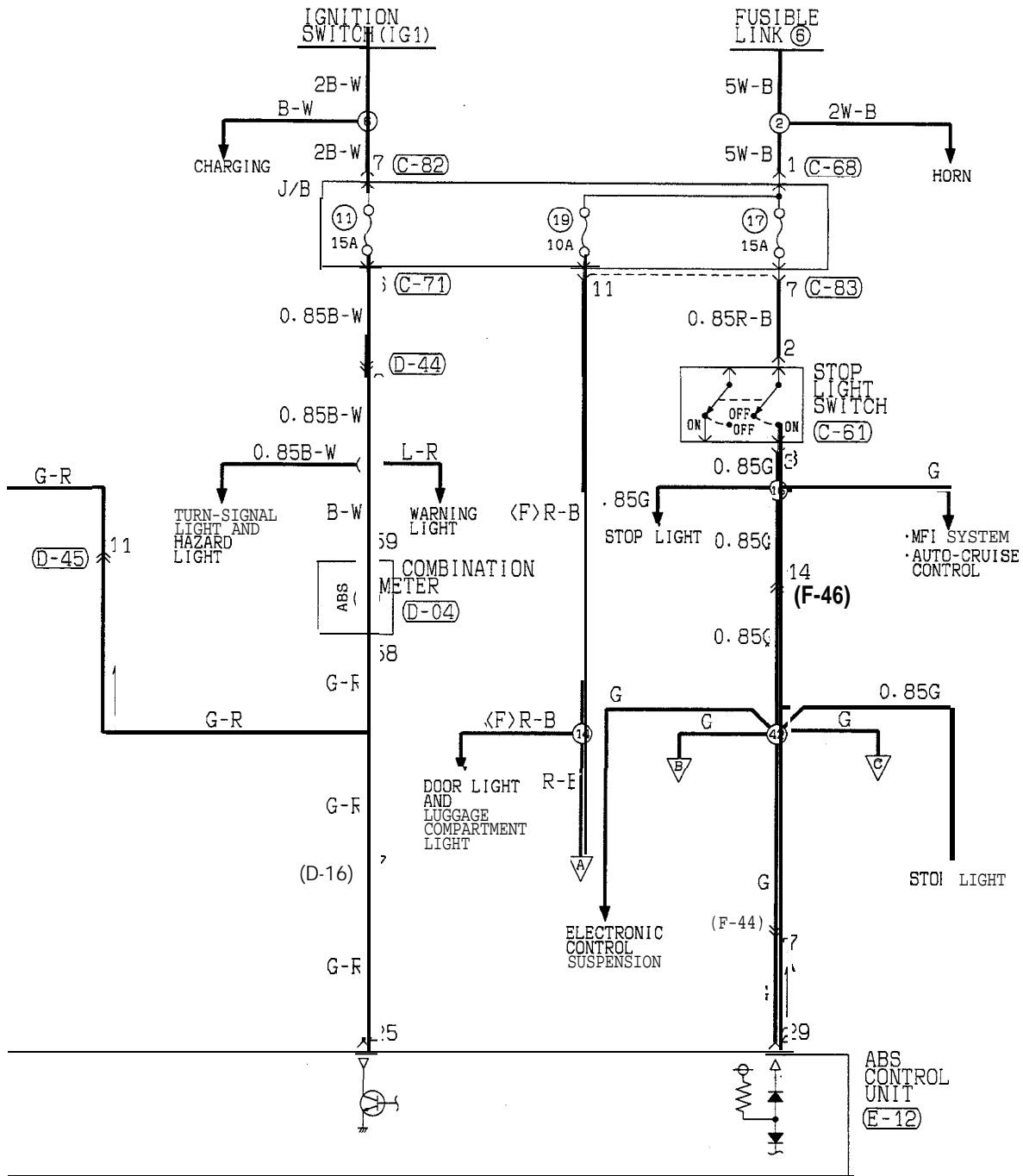

C-61 C-68 C-71



C-82 C-83



D-04

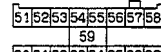

D-16



D-44

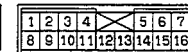

D-45

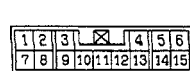

E-12

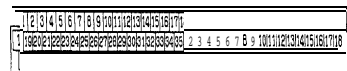

F-19

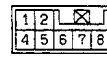

F-44

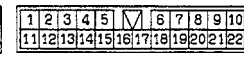

F-46

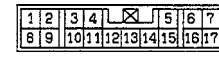

HR15M10AB

**TSB Revision**

ANTI-LOCK BRAKING SYSTEM (ABS) CIRCUIT (1995 MODELS) <AWD>  
(CONVERTIBLE) (CONTINUED)

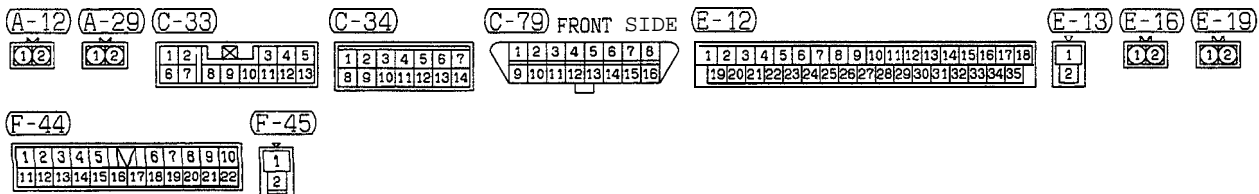
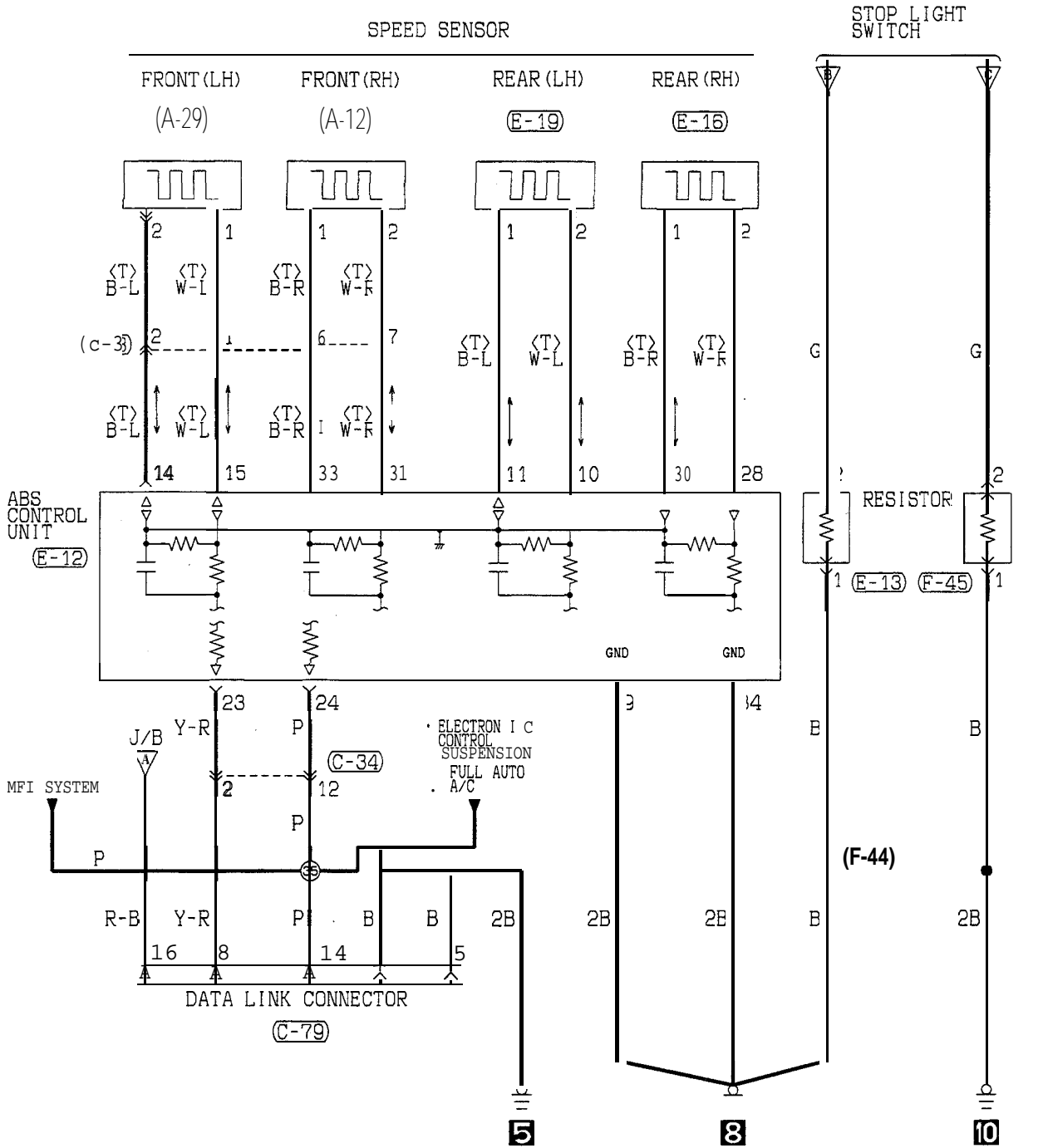

---

NOTES



# ANTI-LOCK BRAKING SYSTEM (ABS) CIRCUIT (FROM 1996 MODELS)

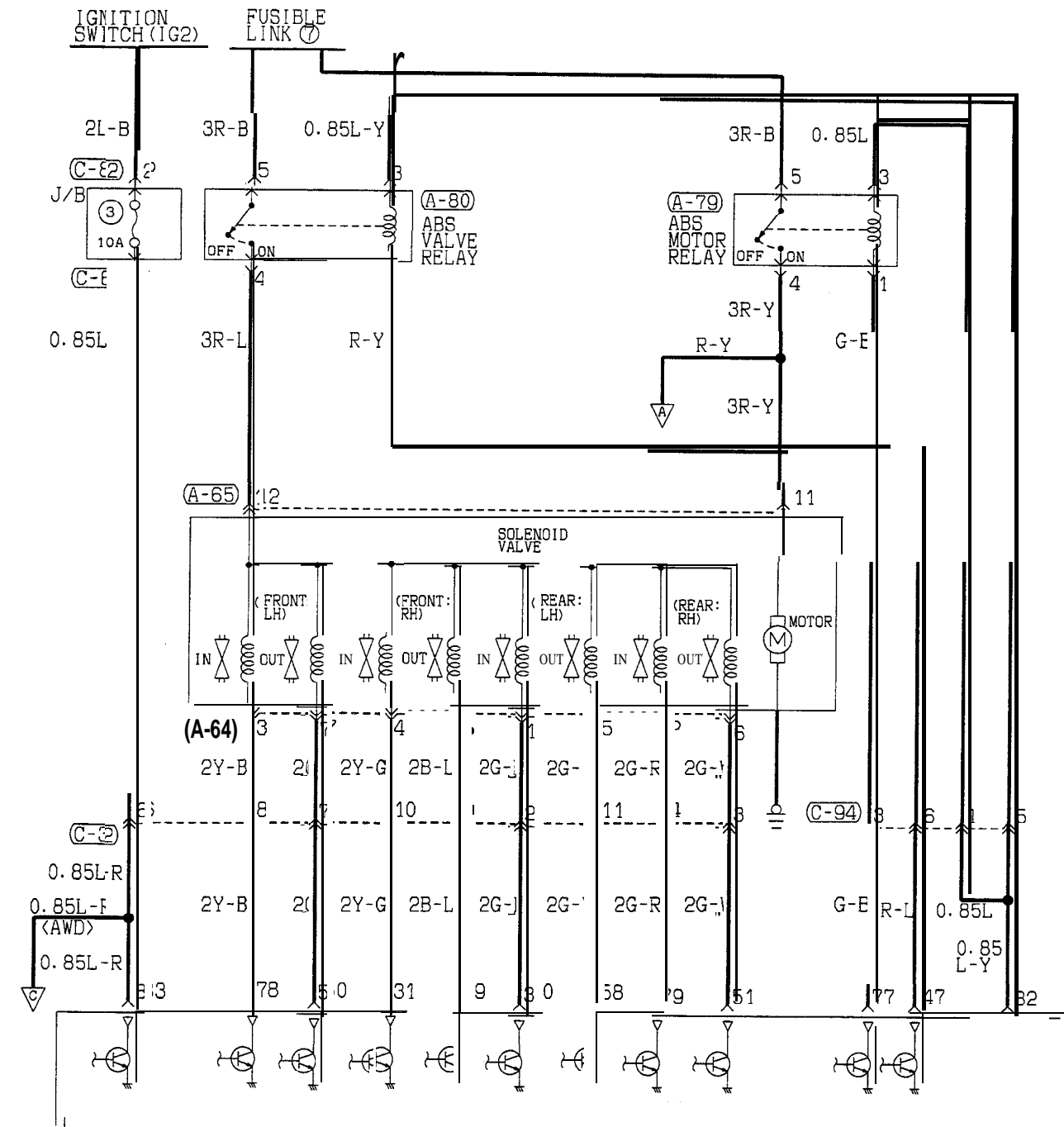

ABS CONTROL UNIT (E-12)

- (A-64) (A-65) (A-79) (A-80) (C-32) (C-69) (C-82) (C-94)

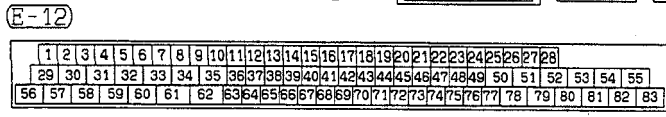

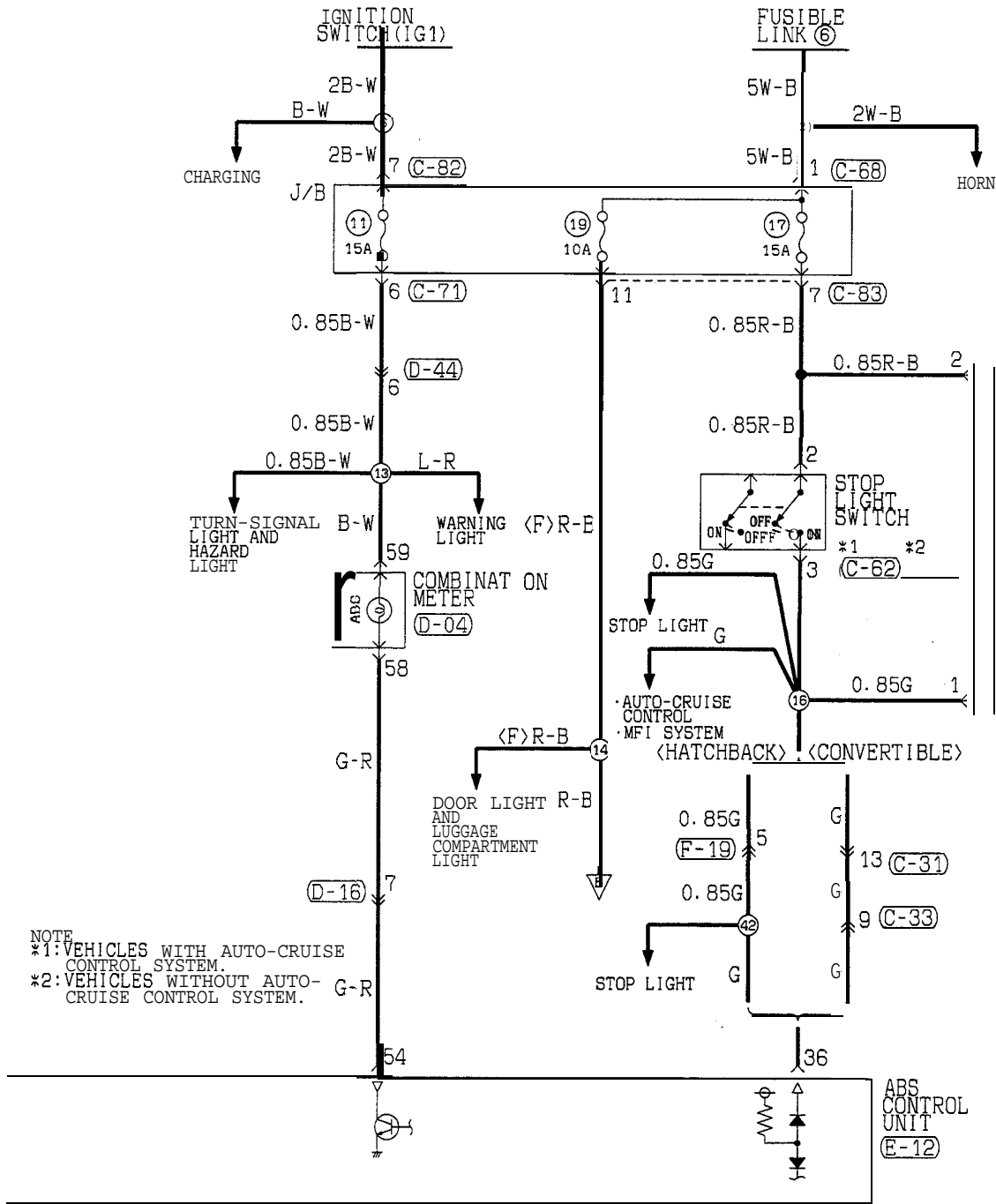

NOTE  
 \*1: VEHICLES WITH AUTO-CRUISE CONTROL SYSTEM.  
 \*2: VEHICLES WITHOUT AUTO-CRUISE CONTROL SYSTEM.

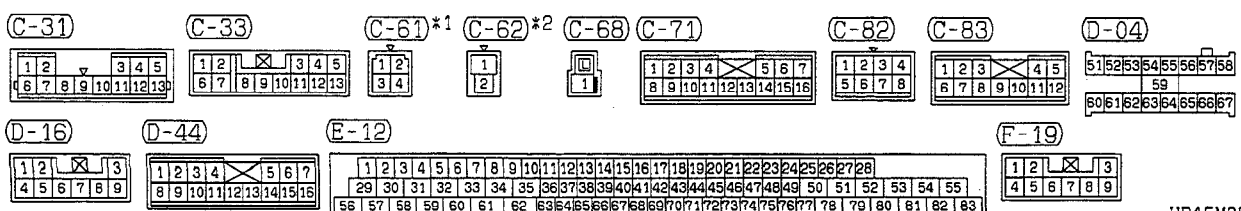

TSB Revision

ANTI-LOCK BRAKING SYSTEM (ABS) CIRCUIT (FROM 1996 MODELS)  
(CONTINUED)

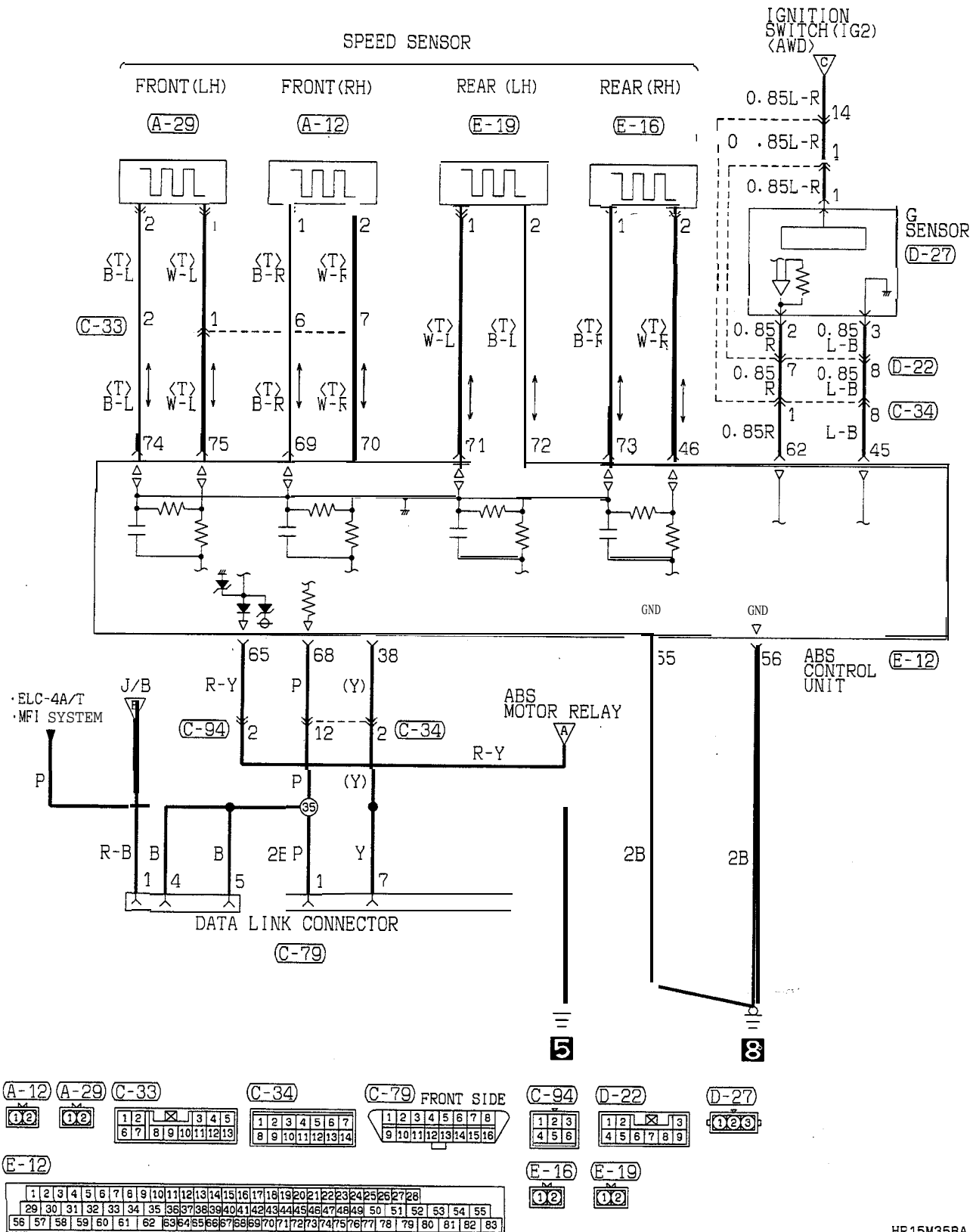

TSB Revision

COMPONENT LOCATION

Name	Symbol	Name	Symbol
ABS control unit	G	G sensor	F
ABS power relay (Up to 1993–October models)	C	Hydraulic unit	A
Data link connector (from 1994 models)	E	Motor relay	A
Data link connector (up to 1993 models)	D	Rear speed sensor	I
Diode (Up to 1995 models)	B	Valve relay	A
Front speed sensor	H		

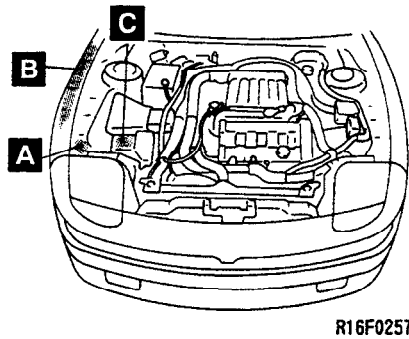

R16F0257

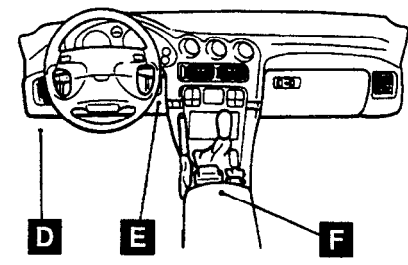

K19F0134

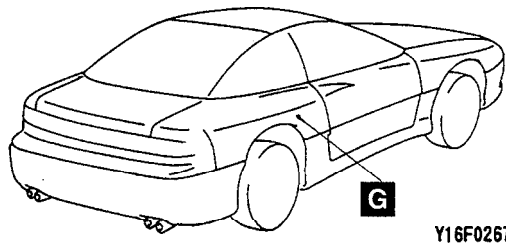

Y16F0267

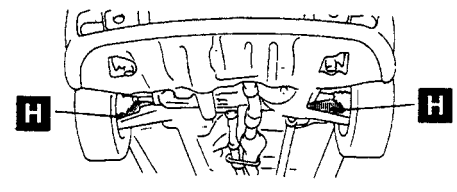

Y16F0040

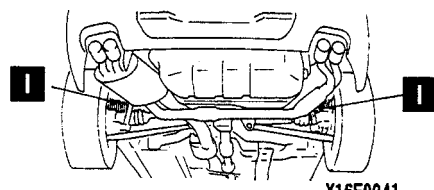

Y16F0041  
00002666

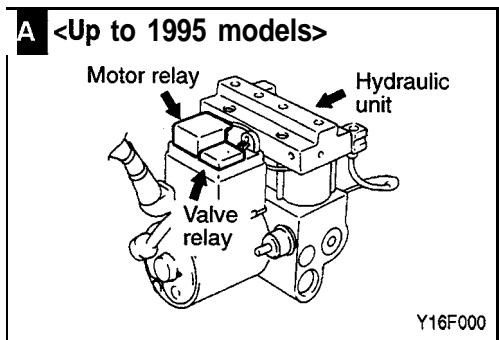

Y16F000

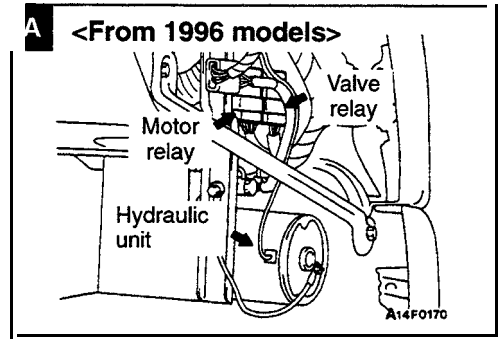

A14F0170

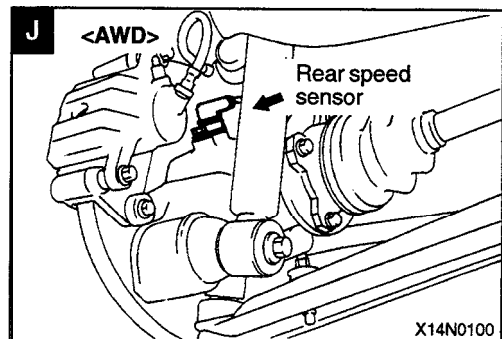
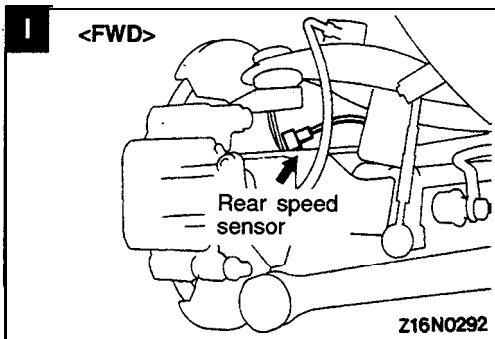
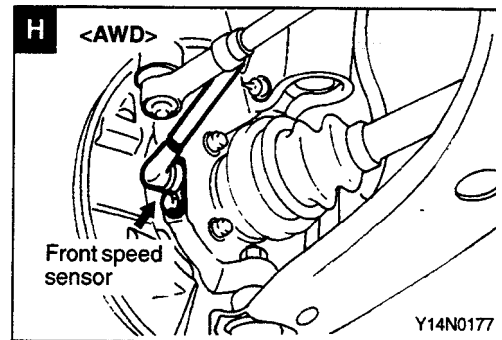
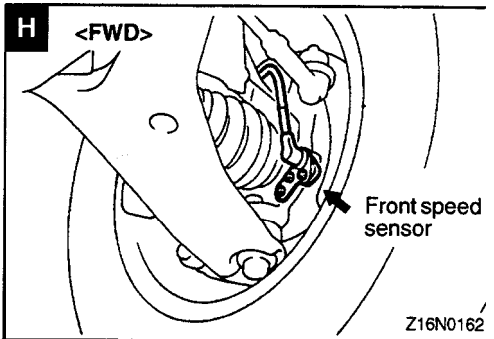
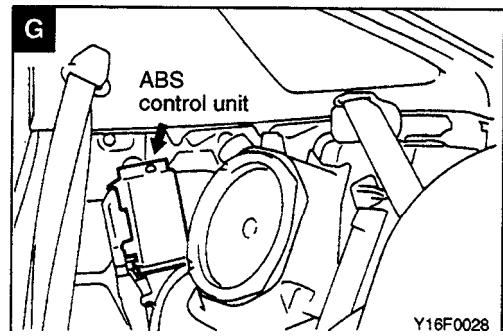
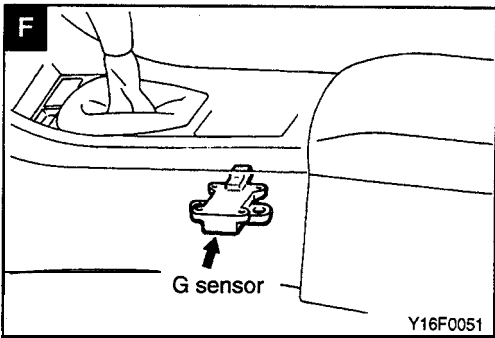
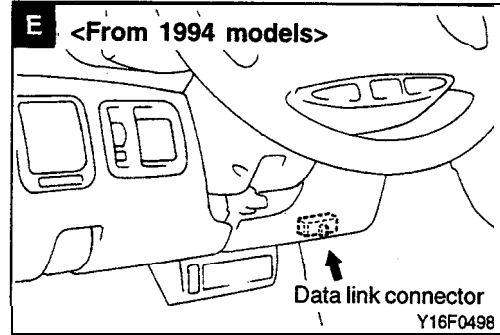
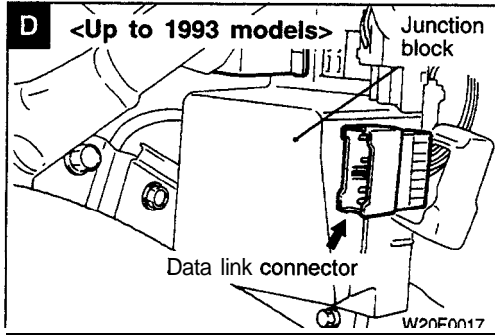
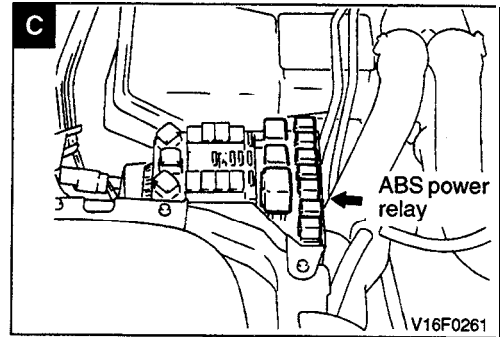
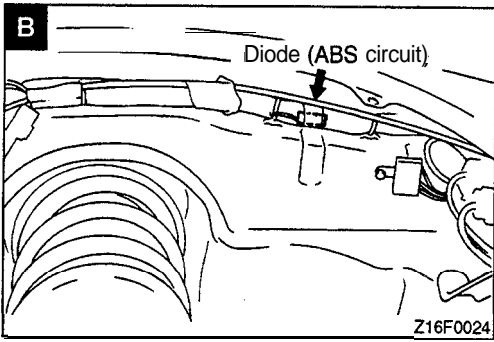

---

NOTES

# ELECTRONIC CONTROL SUSPENSION (ECS) CIRCUIT (UP TO 1993 MODELS)

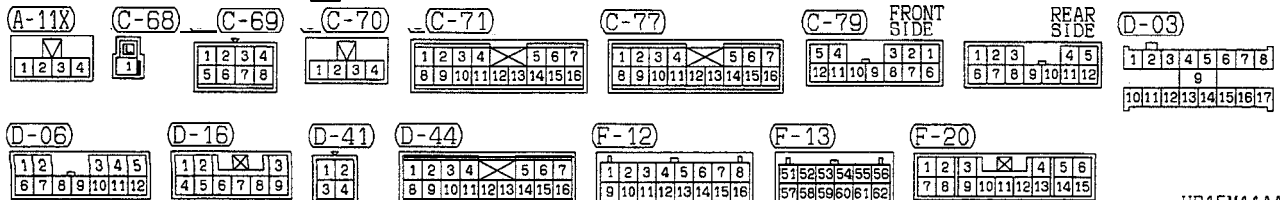
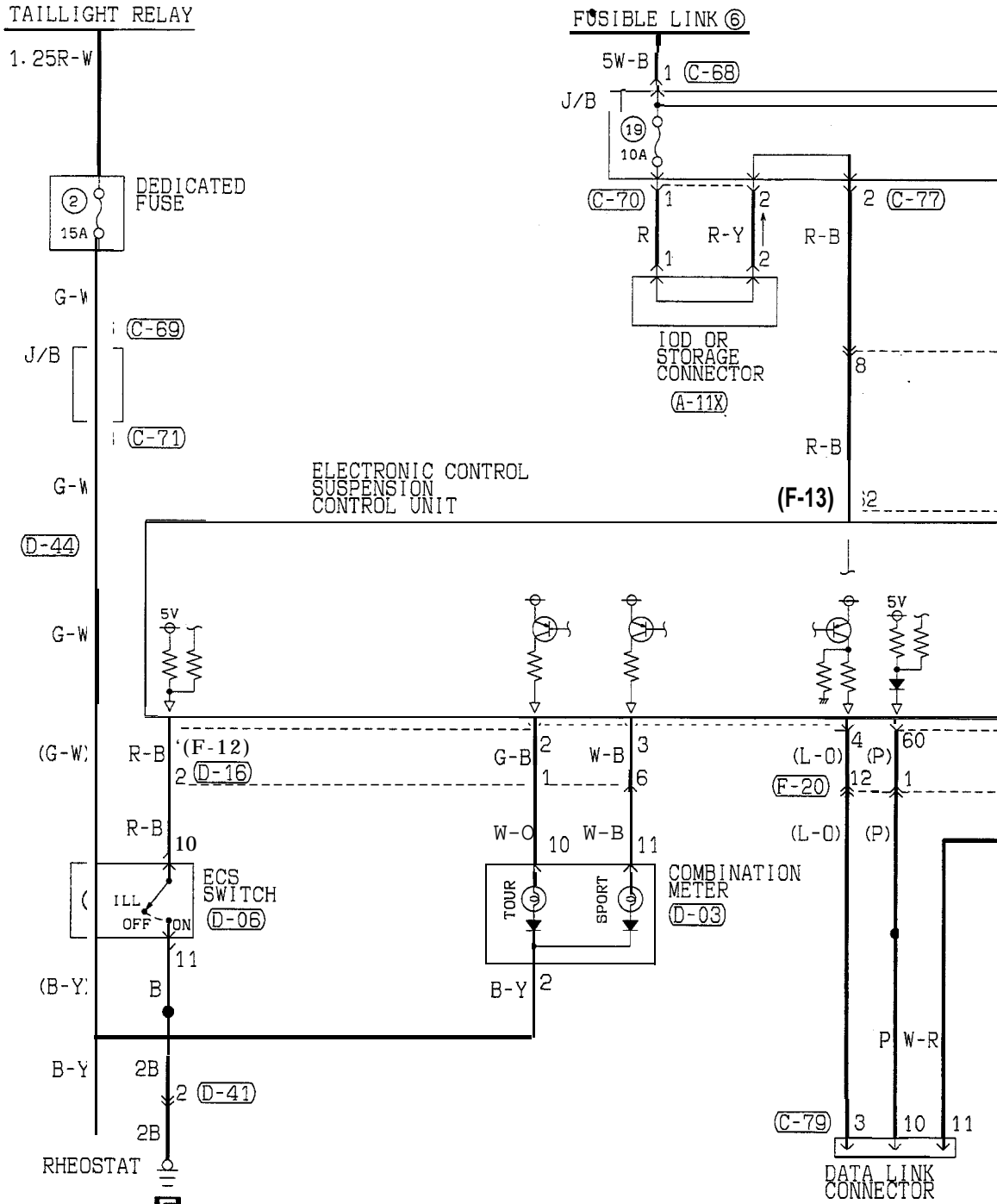

TSB Revision

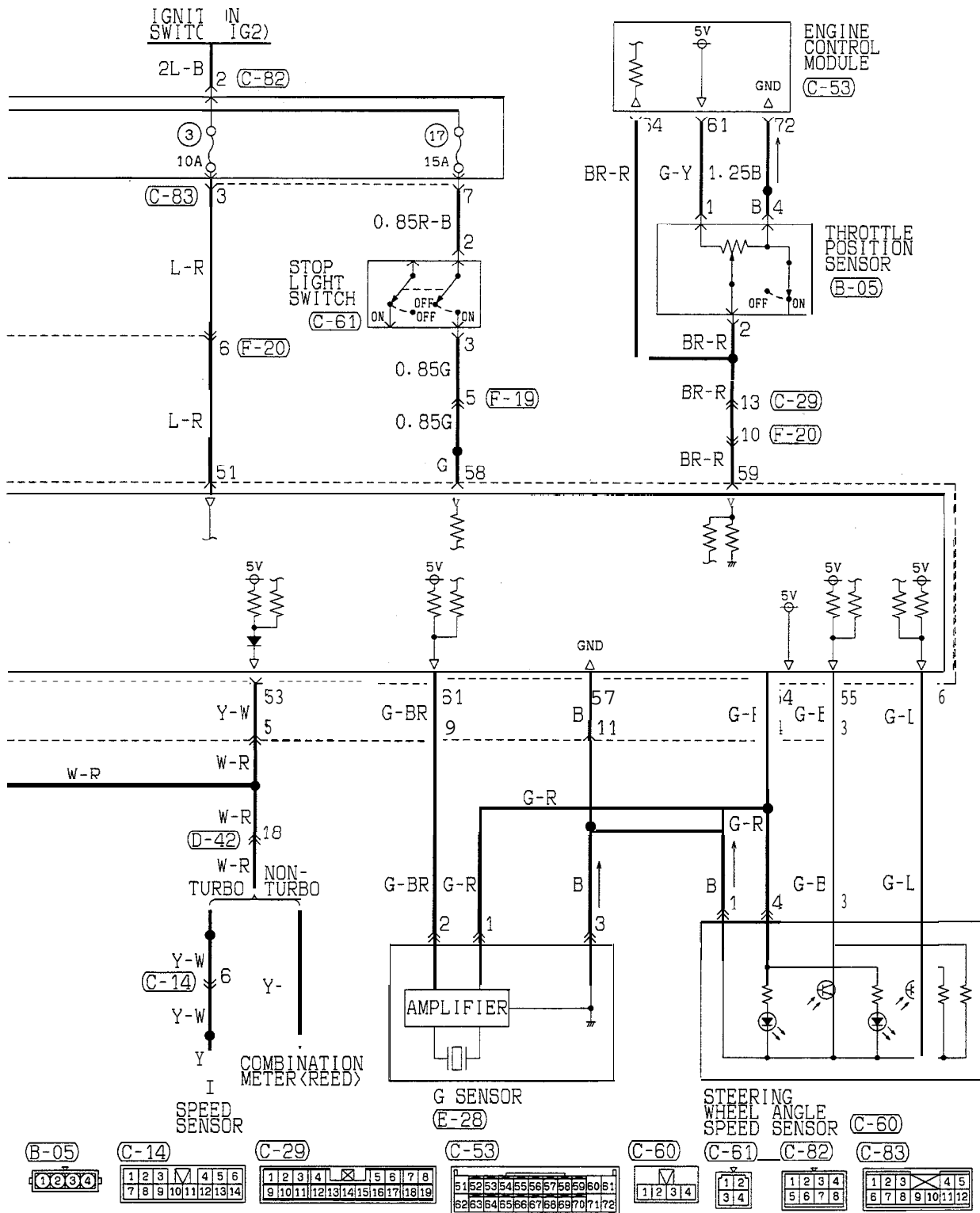

<b>B-05</b> 1 2 3 4	<b>C-14</b> 1 2 3 4 5 6 7 8 9 10 11 12 13 14	<b>C-29</b> 1 2 3 4 5 6 7 8 9 10 11 12 13 14 15 16 17 18 19	<b>C-53</b> 51 52 53 54 55 56 57 58 59 60 61 62 63 64 65 66 67 68 69 70 71 72	<b>C-60</b> 1 2 3 4	<b>C-61</b> 1 2 3 4	<b>C-82</b> 1 2 3 4 5 6 7 8	<b>C-83</b> 1 2 3 4 5 6 7 8 9 10 11 12
<b>D-42</b> 1 2 3 4 5 6 7 8 9 10 11 12 13 14 15 16 17 18 19 20 21 22	<b>E-28</b> 1 2 3	<b>F-19</b> 1 2 3 4 5 6 7 8 9	<b>F-20</b> 1 2 3 4 5 6 7 8 9 10 11 12 13 14 15				

TSB Revision



**ELECTRONIC CONTROL SUSPENSION (ECS) CIRCUIT  
(UP TO 1993 MODELS) (CONTINUED)**

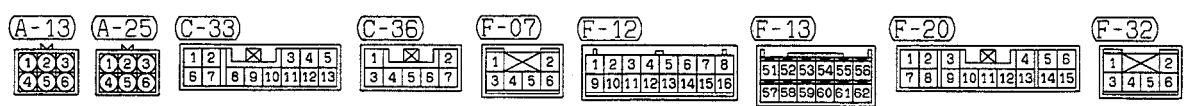
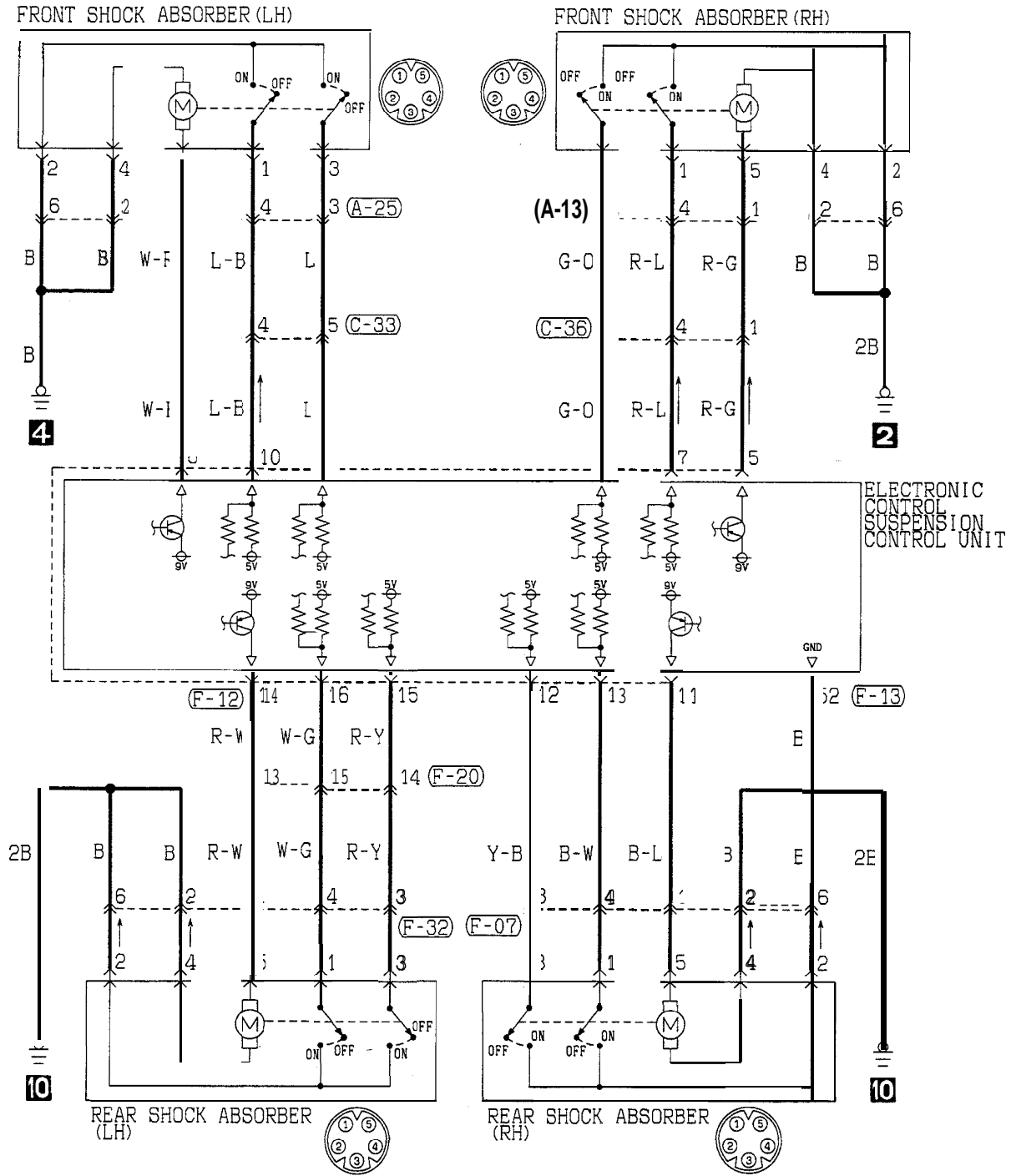

---

NOTES

**ELECTRONIC CONTROL SUSPENSION (ECS) CIRCUIT**

(1994 MODELS)

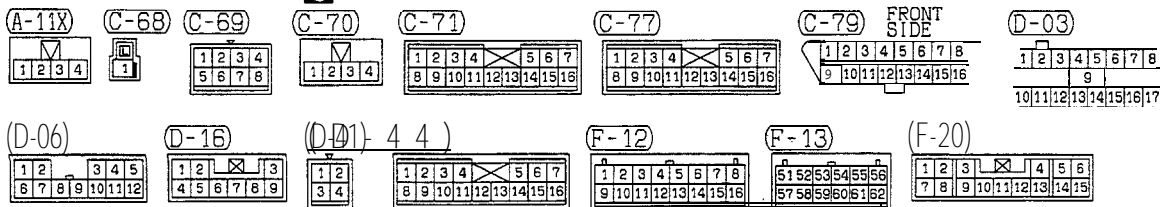
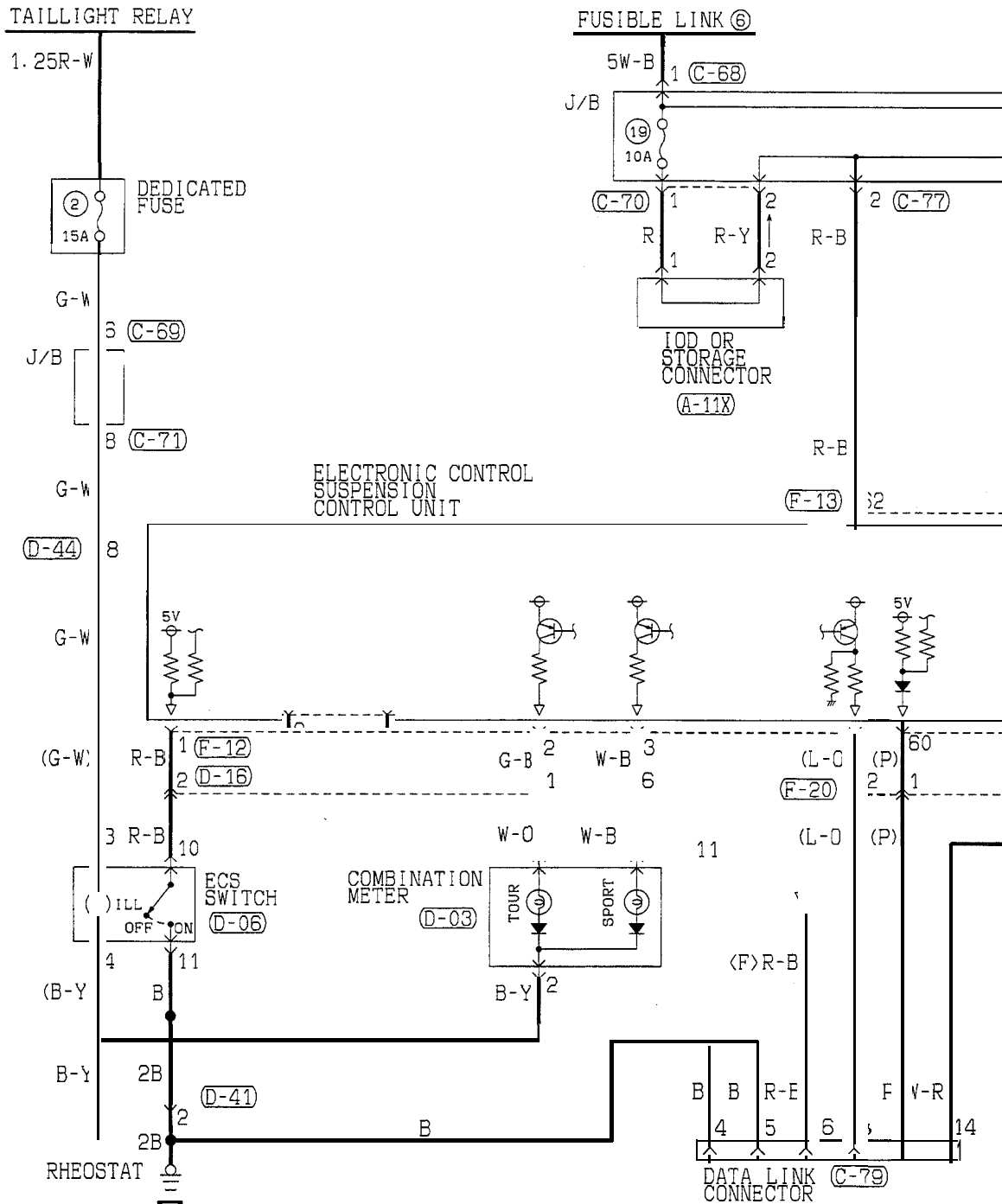

TSB Revision

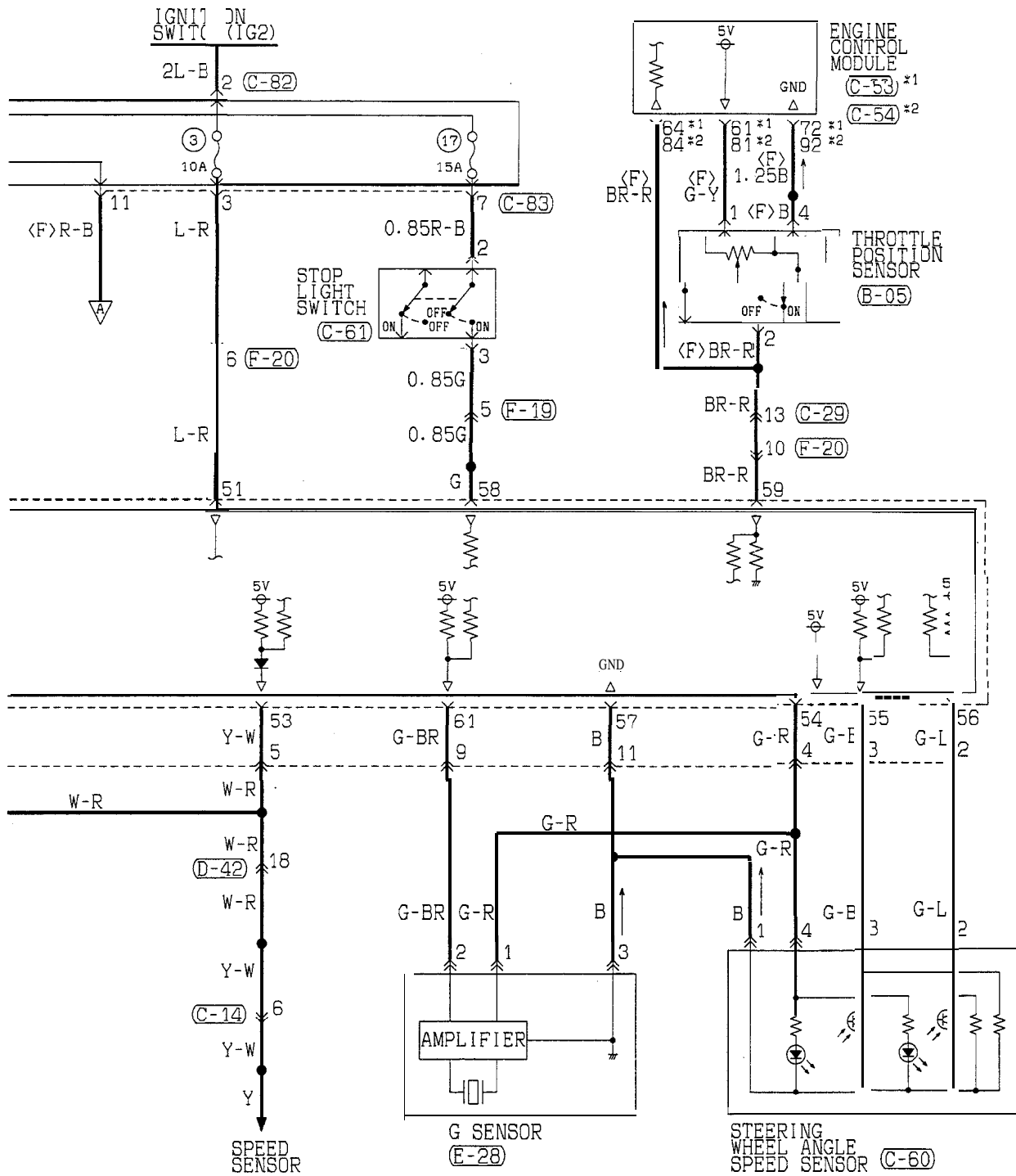

<b>B-05</b> 1 2 3 4	<b>C-14</b> 1 2 3 4 5 6 7 8 9 10 11 12 13 14	<b>C-29</b> 1 2 3 4 5 6 7 8 9 10 11 12 13 14 15 16 17 18 19	<b>C-53</b> 51 52 53 54 55 56 57 58 59 60 61 62 63 64 65 66 67 68 69 70 71 72	<b>C-54</b> 71 72 73 74 75 76 77 78 79 80 81 82 83 84 85 86 87 88 89 90 91 92	<b>C-60</b> 1 2 3 4	<b>C-61</b> 1 2 3 4
<b>C-82</b> 1 2 3 4 5 6 7 8	<b>C-83</b> 1 2 3 4 5 6 7 8 9 10 11 12	<b>D-42</b> 1 2 3 4 5 6 7 8 9 10 11 12 13 14 15 16 17 18 19 20 21 22	<b>E-28</b> 1 2 3	<b>F-19</b> 1 2 3 4 5 6 7 8 9	<b>F-20</b> 1 2 3 4 5 6 7 8 9 10 11 12 13 14 15	

TSB Revision

ELECTRONIC CONTROL SUSPENSION (ECS) CIRCUIT  
(1994 MODELS) (CONTINUED)

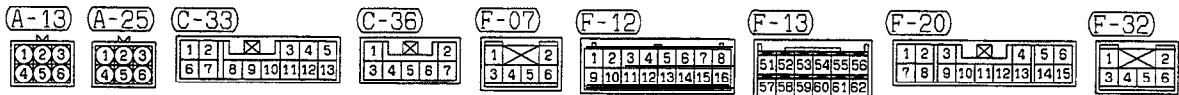
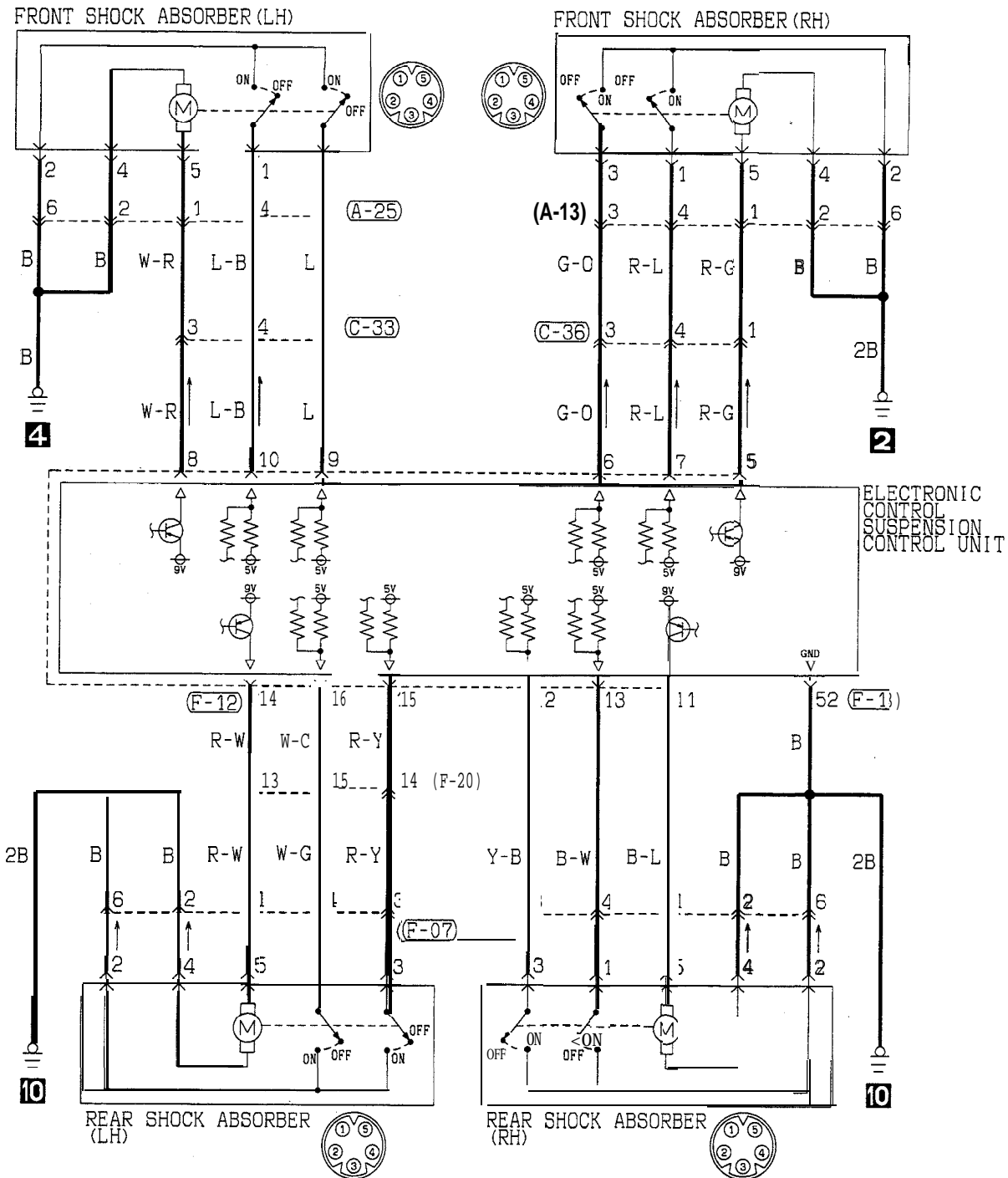

---

NOTES

# ELECTRONIC CONTROL SUSPENSION (ECS) CIRCUIT (1995 MODELS) <HATCHBACK>

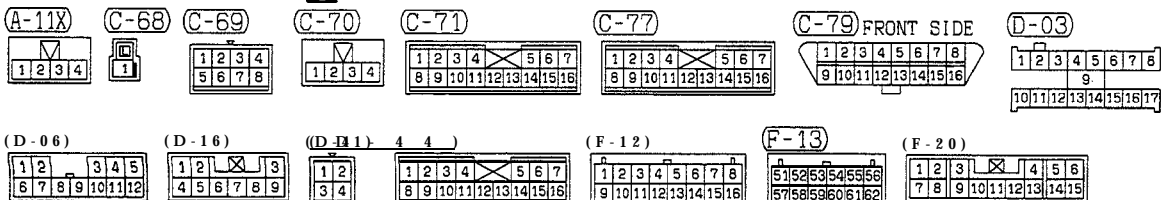
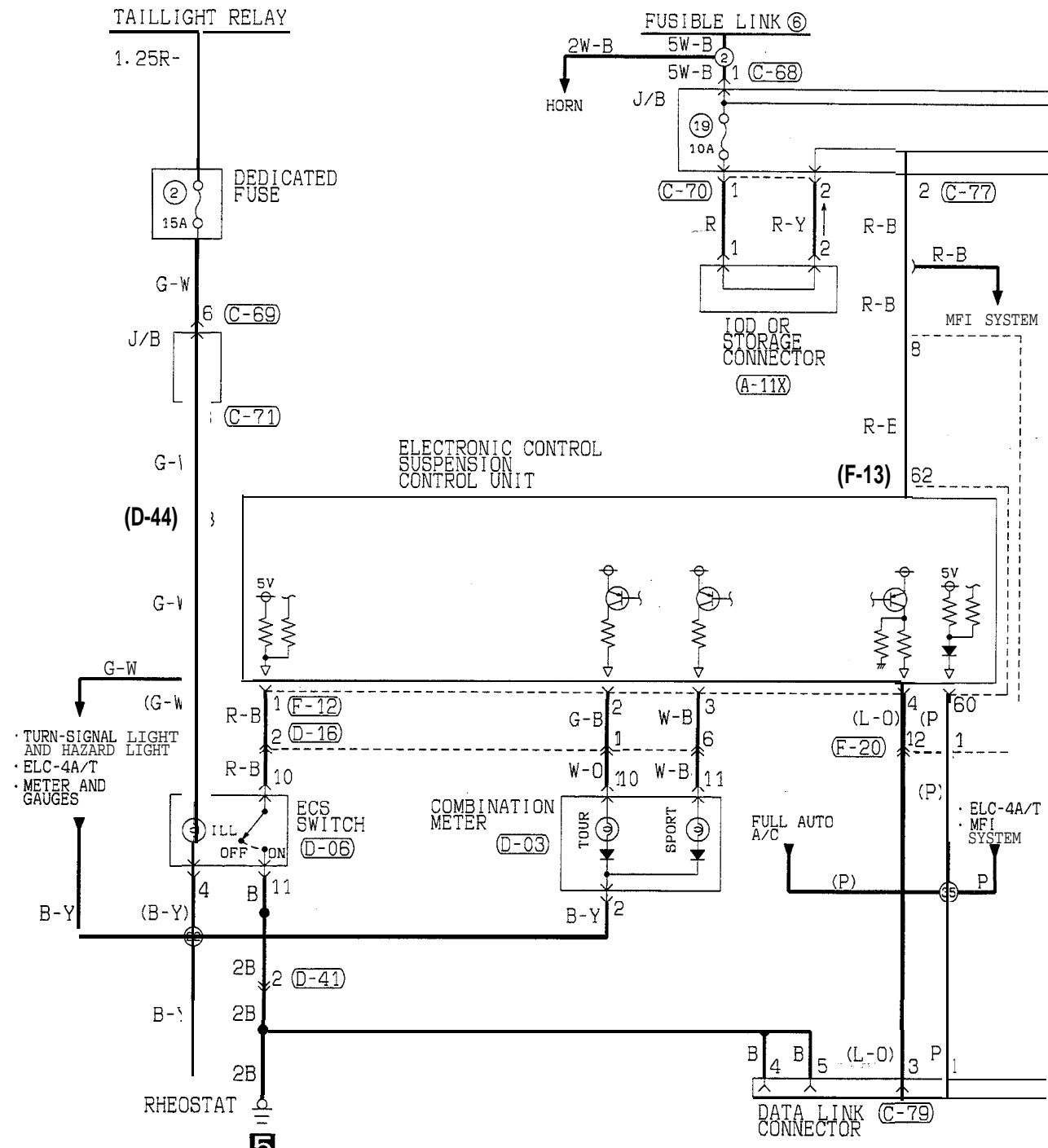

TSB Revision

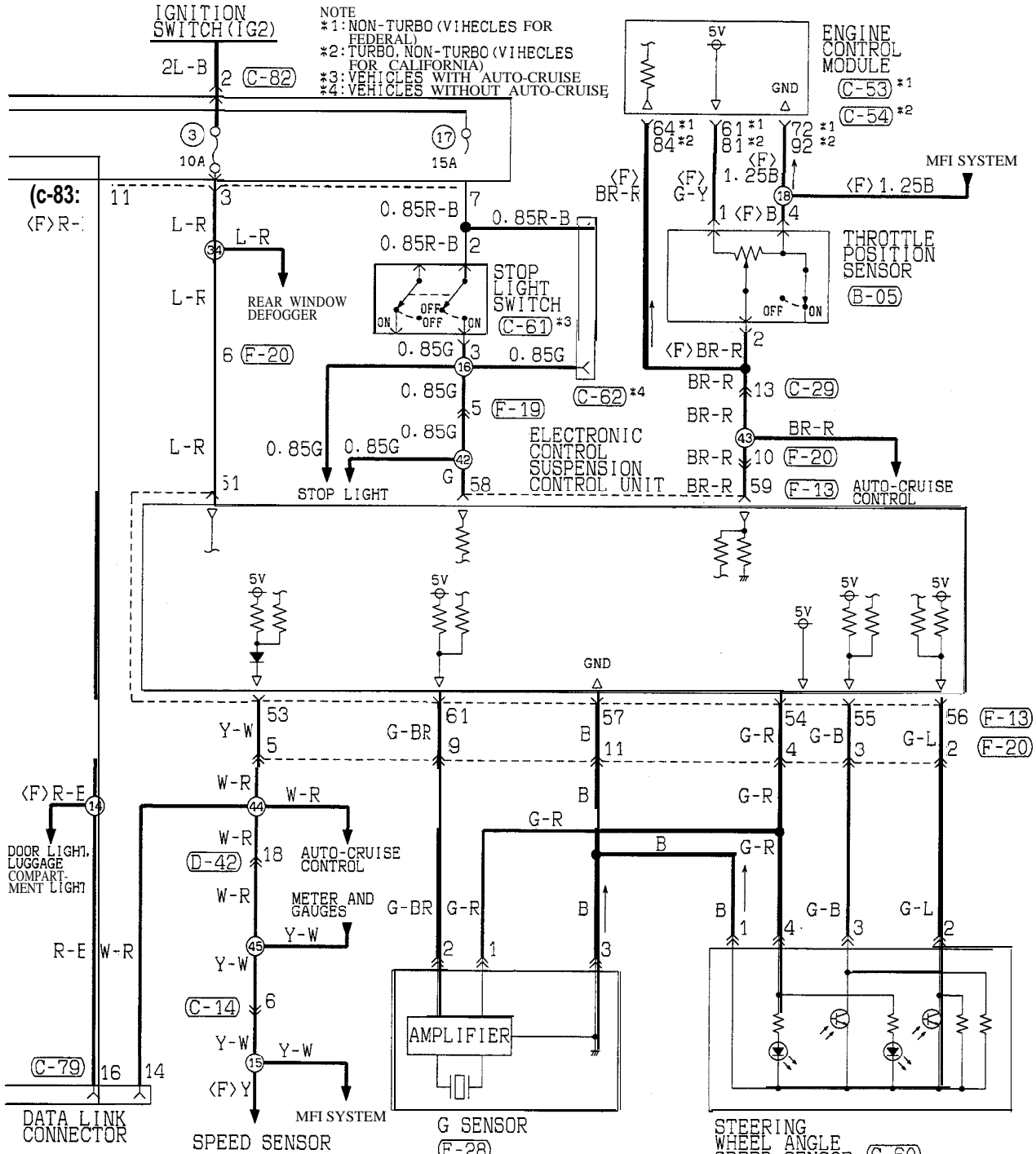

NOTE  
 \*1: NON-TURBO (VEHICLES FOR FEDERAL)  
 \*2: TURBO, NON-TURBO (VEHICLES FOR CALIFORNIA)  
 \*3: VEHICLES WITH AUTO-CRUISE  
 \*4: VEHICLES WITHOUT AUTO-CRUISE

(C-83: <F>R-11

(F)R-E 14  
 DOOR LIGHT, LUGGAGE COMPARTMENT LIGHT

DATA LINK CONNECTOR

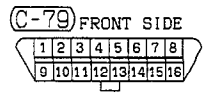
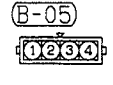



ELECTRONIC CONTROL SUSPENSION (ECS) CIRCUIT (1995 MODELS)  
 <HATCHBACK> (CONTINUED)

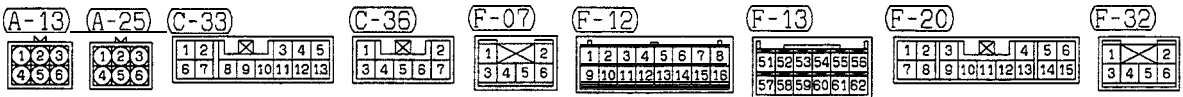
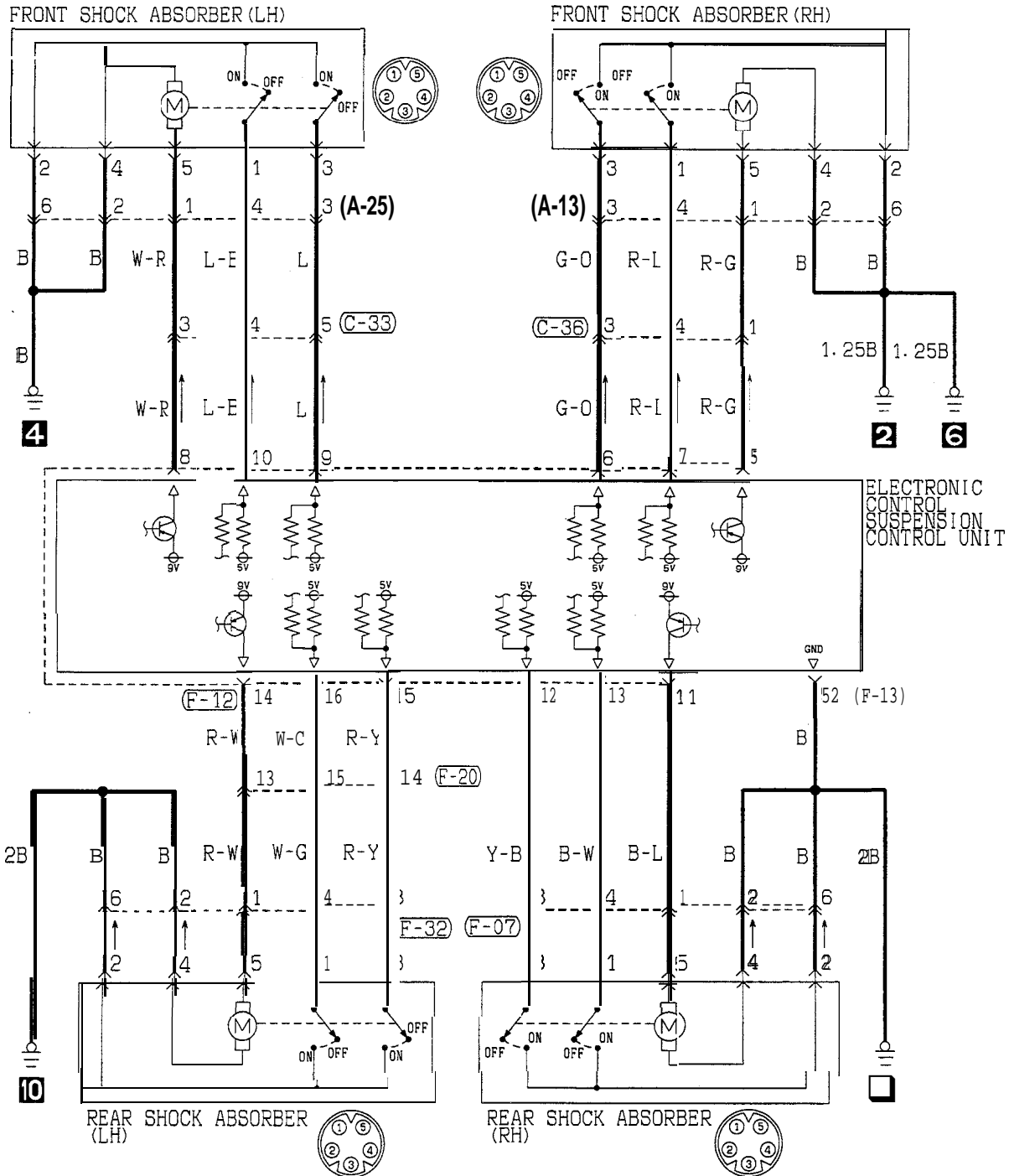

---

NOTES

# ELECTRONIC CONTROL SUSPENSION (ECS) CIRCUIT (1995 MODELS)

<CONVERTIBLE>

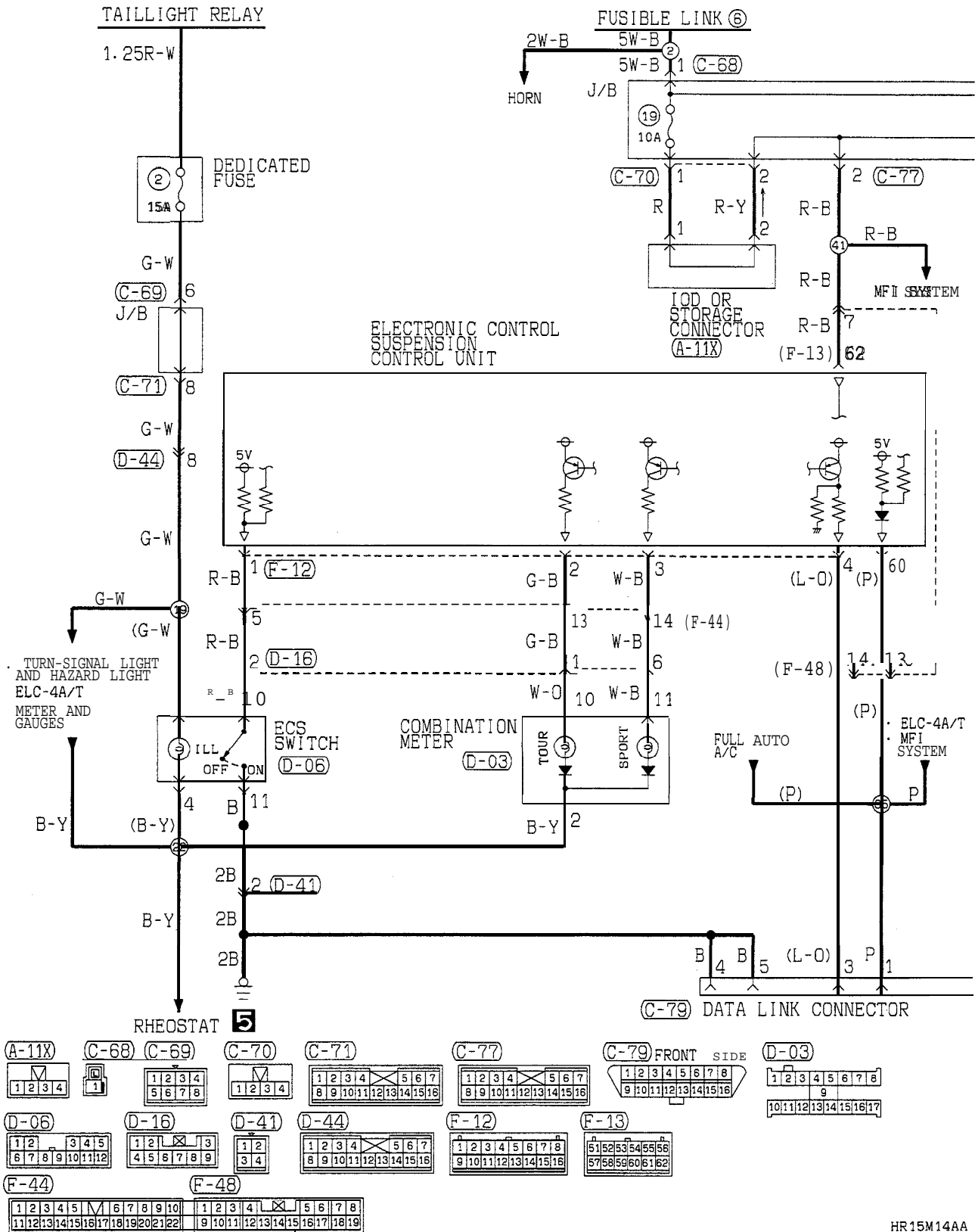

TSB Revision

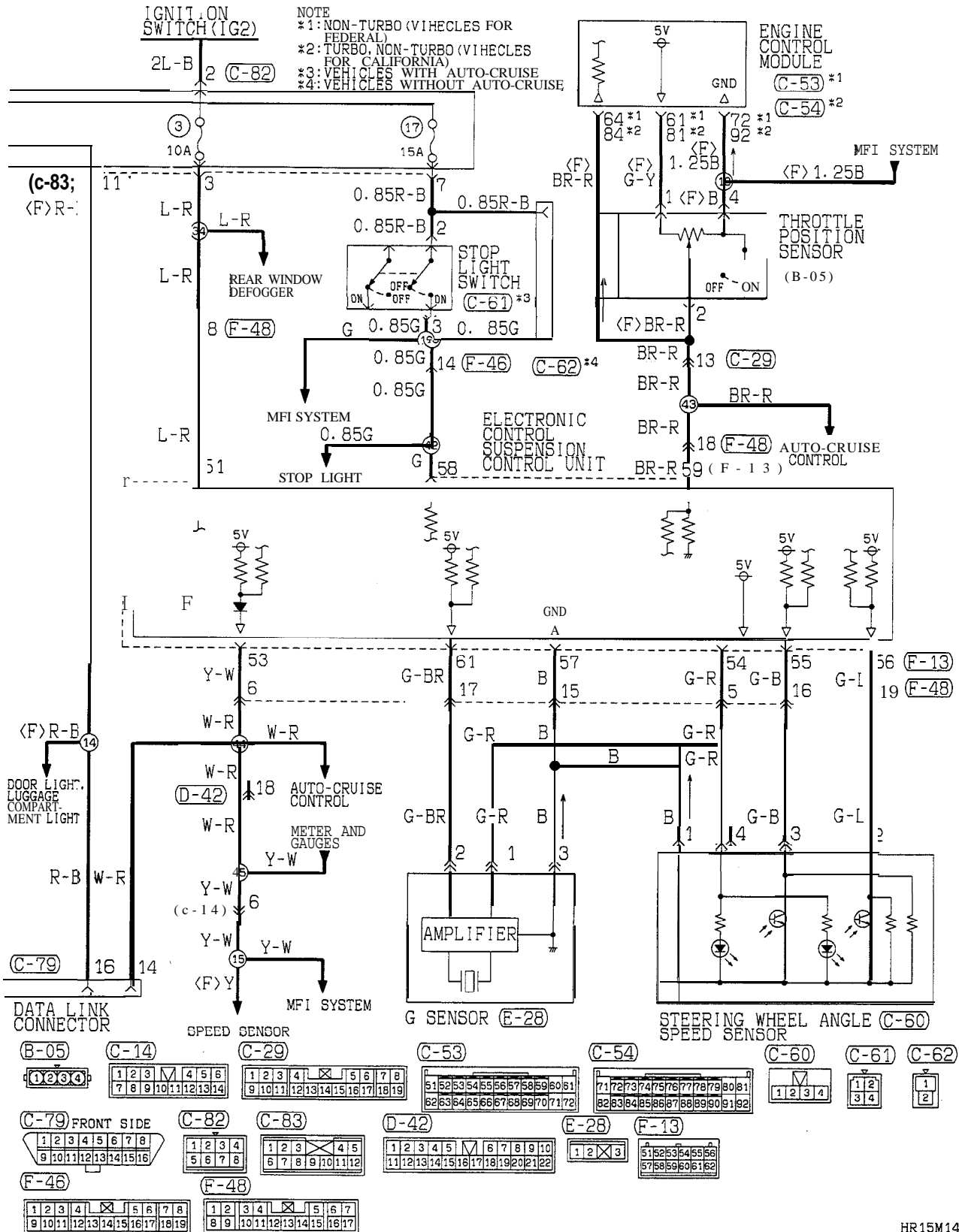

ELECTRONIC CONTROL SUSPENSION (ECS) CIRCUIT (1995 MODELS)  
 <CONVERTIBLE> (CONTINUED)

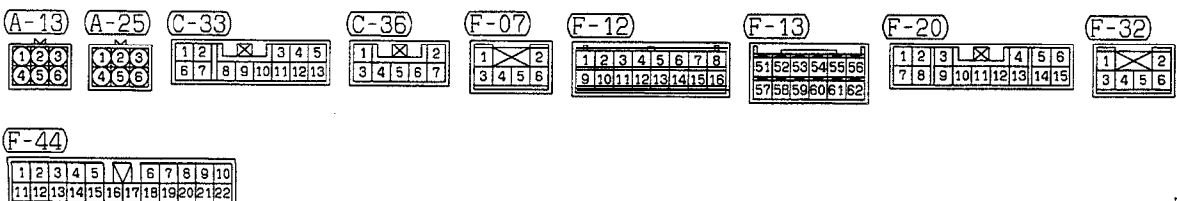
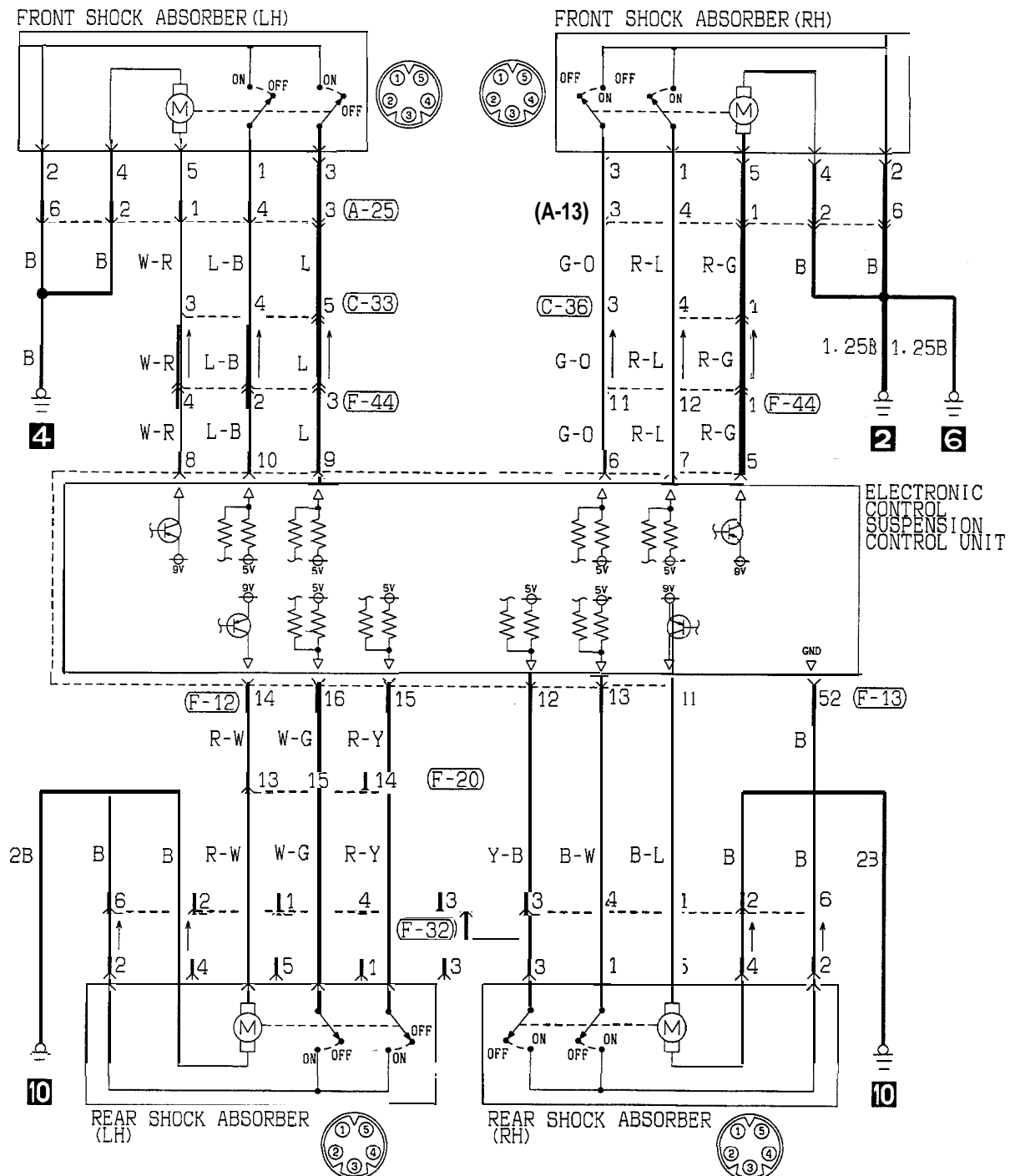

COMPONENT LOCATION

Name	Symbol	Name	Symbol
Data link connector (from 1994 models)	D	G sensor	E
Data link connector (up to 1993 models)	F	Steering wheel angle speed sensor	B
ECS control unit	G	Throttle position sensor	A
Engine control module	C		

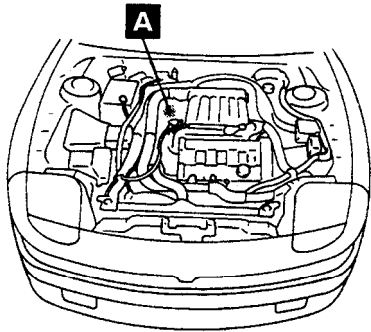

Q16F0257

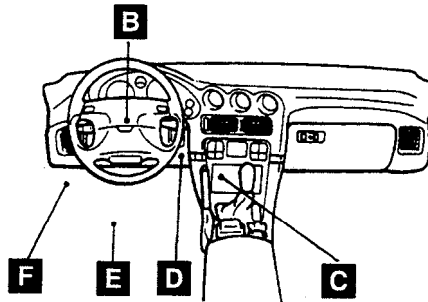

K19F0134

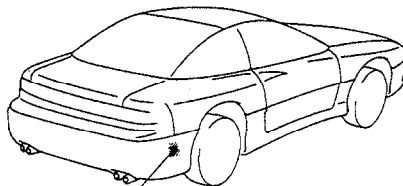

Y16F0267  
00002609

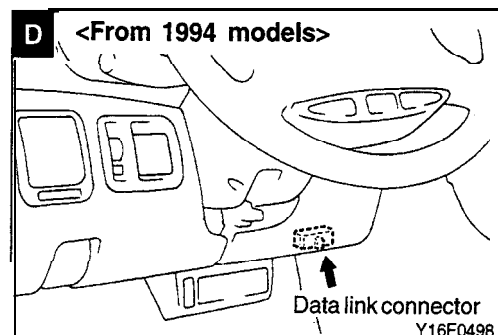
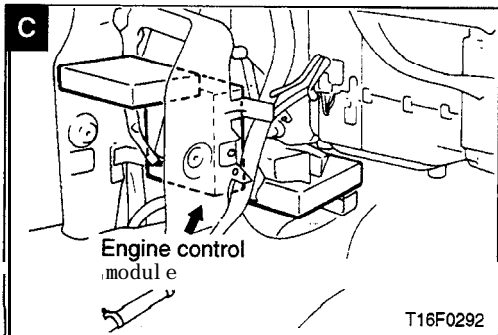
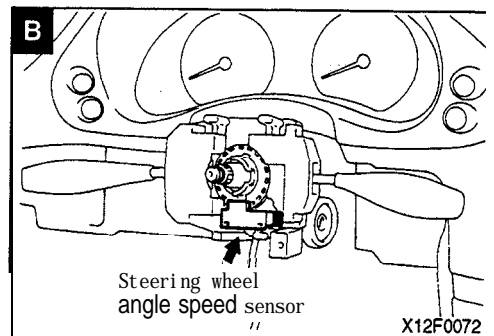
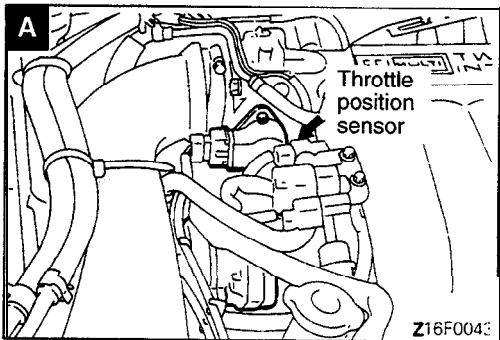

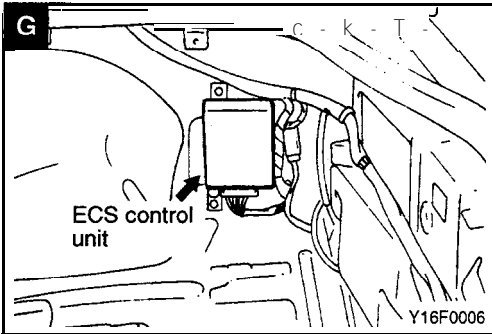
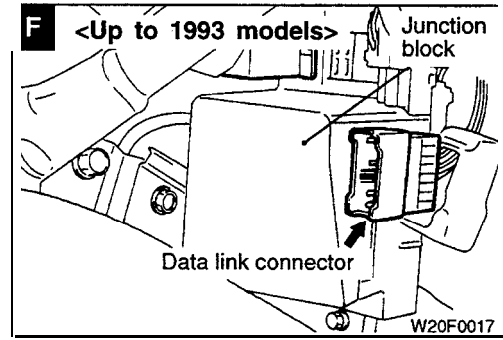
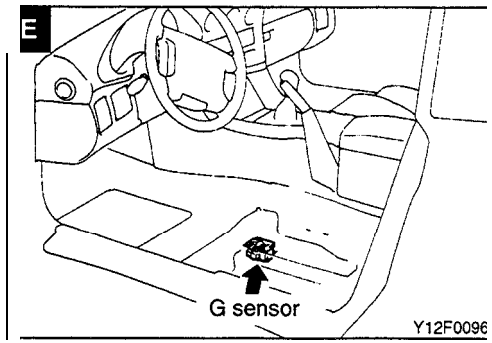

# ACTIVE EXHAUST SYSTEM

## COMPONENT LOCATION

Name	Symbol	Name	Symbol
Active exhaust control unit	C	Engine control module	B
Actuator assembly	D	Power window relay	A

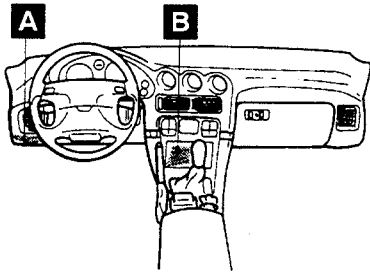

I19F0134

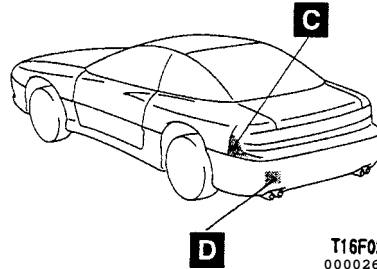

T16F0268  
00002666

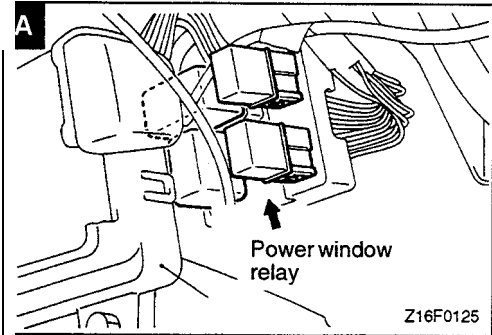

Z16F0125

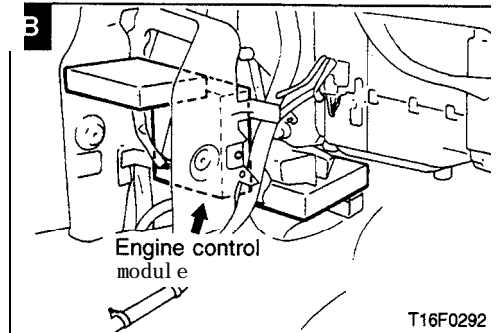

T16F0292

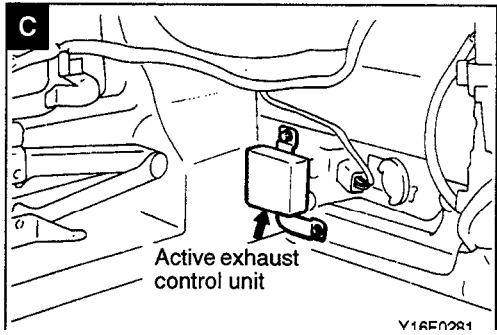

V16F0281

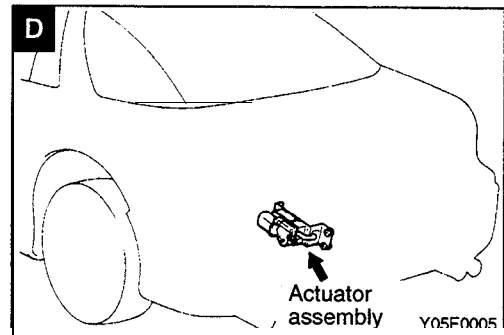

Y05F0005



ACTIVE EXHAUST SYSTEM CIRCUIT (UP TO 1993 MODELS)

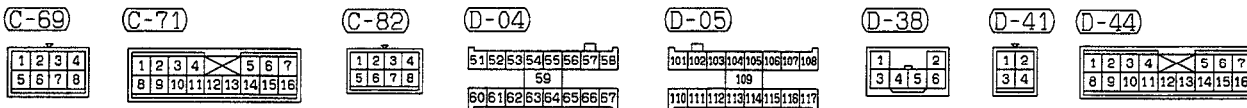
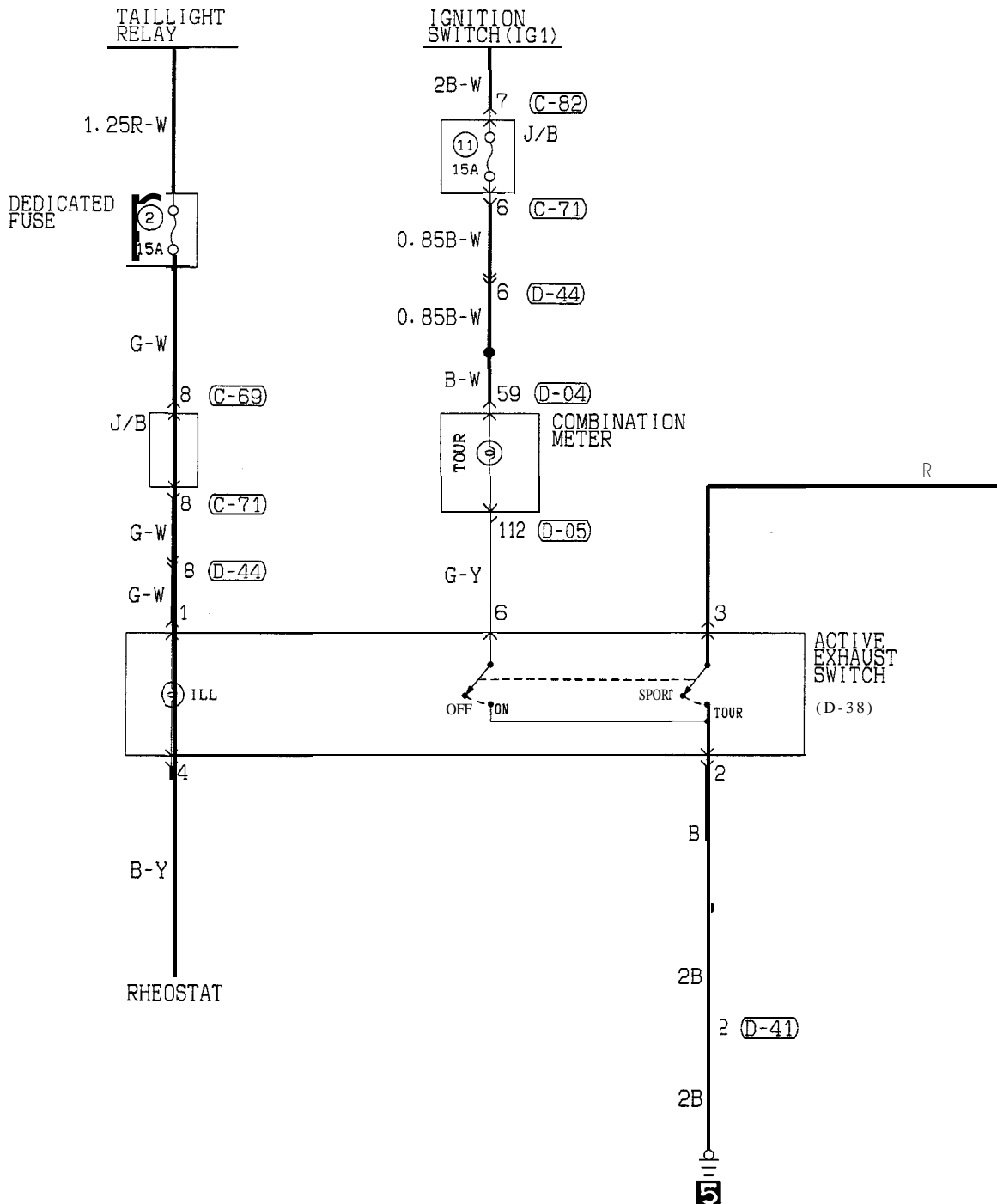

TSB Revision

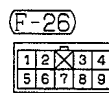
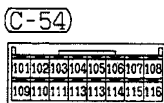
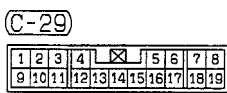
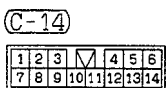
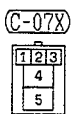
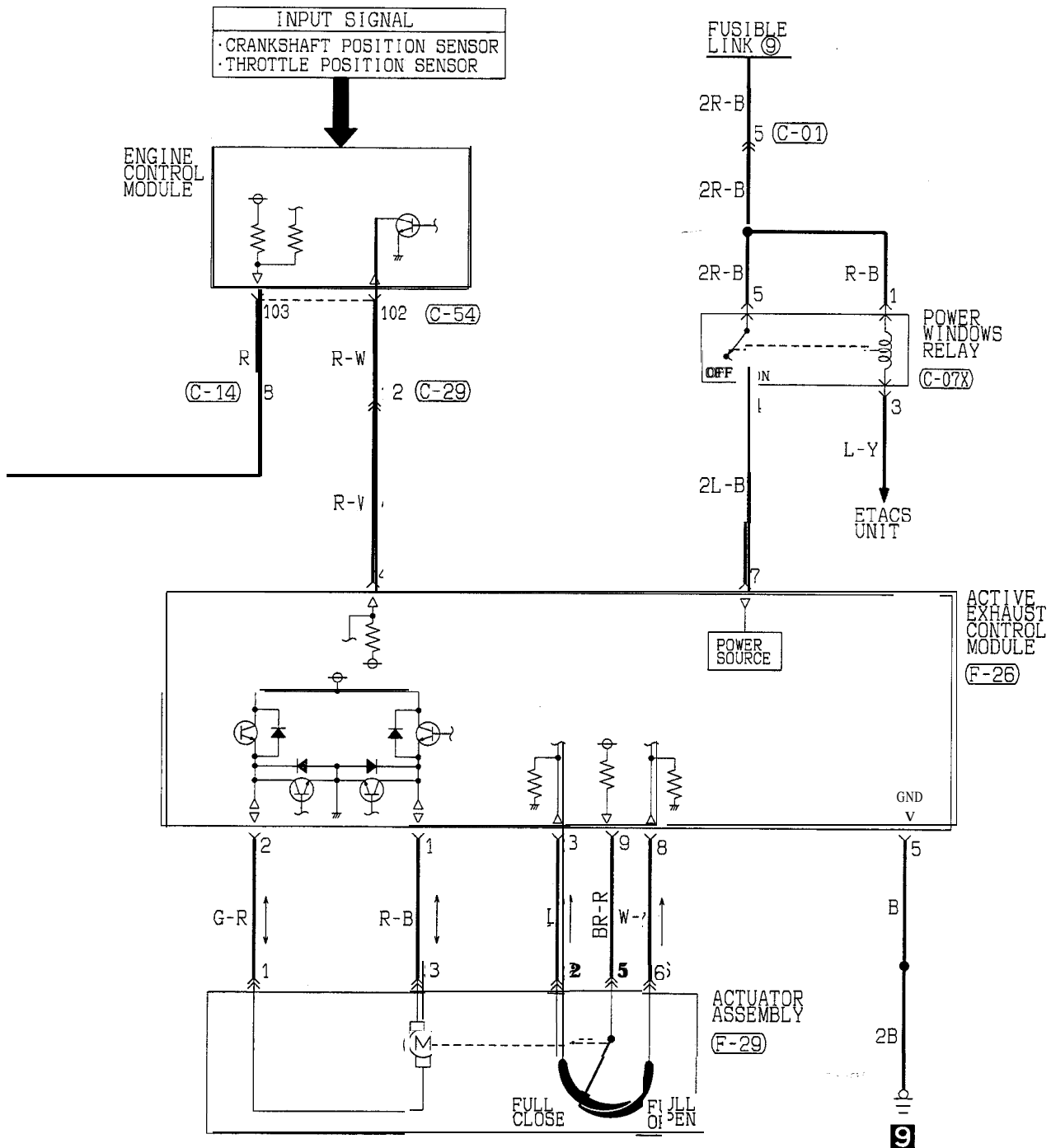

TSB Revision

ACTIVE EXHAUST SYSTEM CIRCUIT (1994 MODELS)

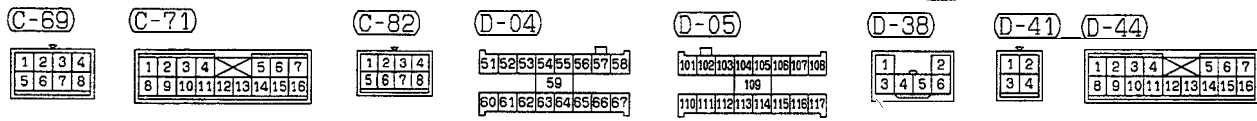
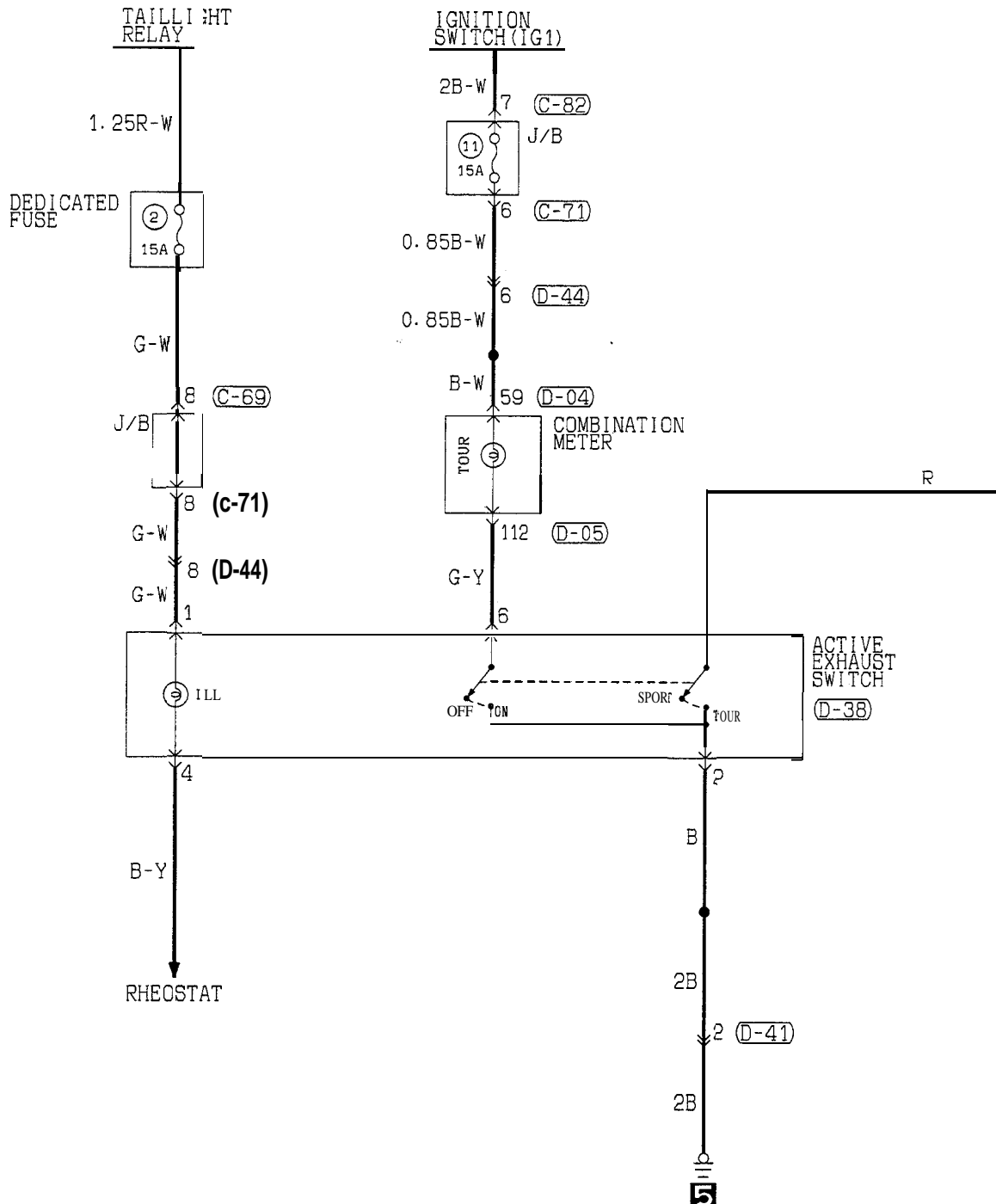

TSB Revision

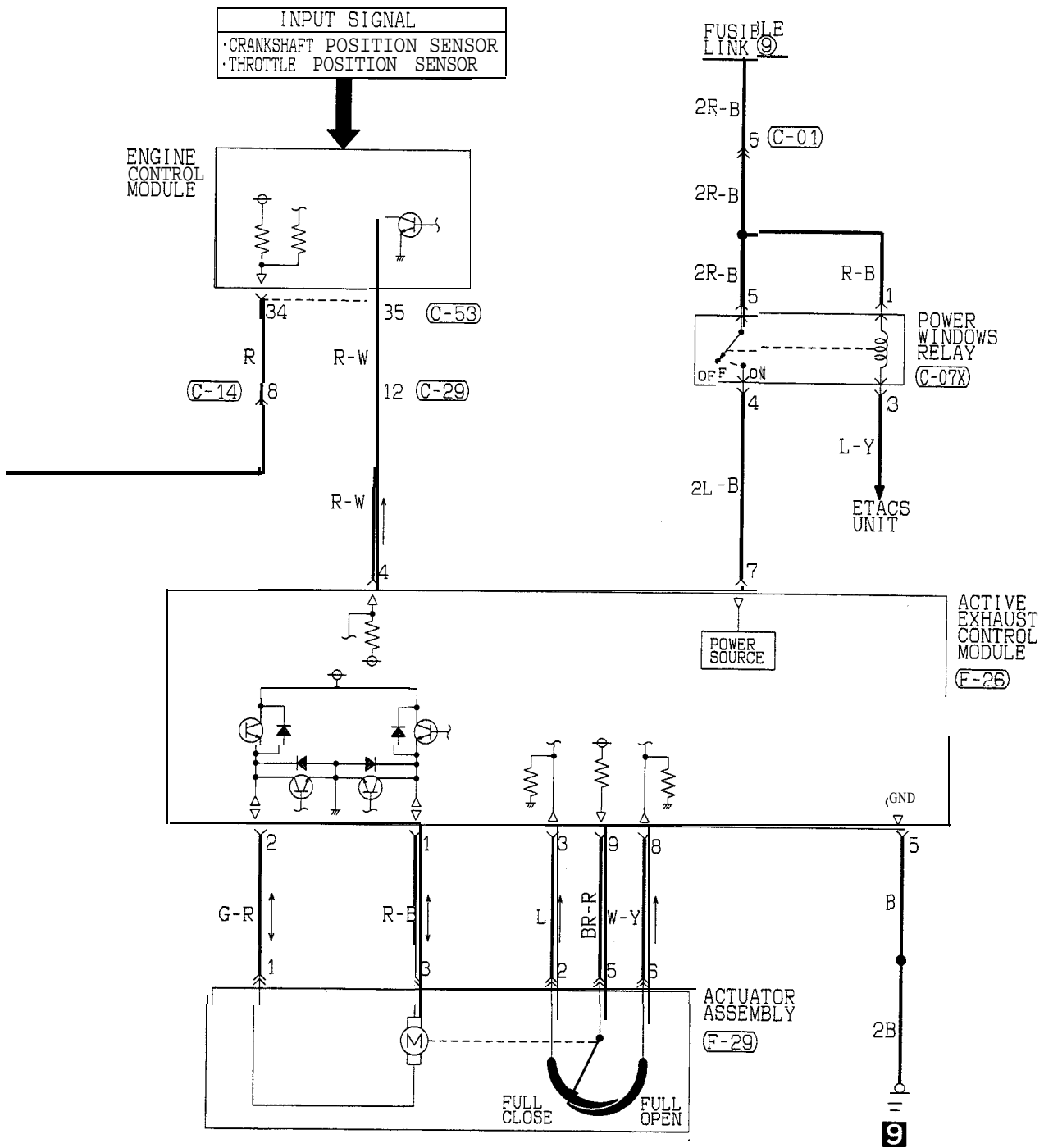

C-01

1	2	3	4
5	6	7	8

C-07X

1	2	3
4		
5		

C-14

1	2	3	4	5	6
7	8	9	10	11	12
13	14				

C-29

1	2	3	4	5	6	7	8
9	10	11	12	13	14	15	16
17	18	19					

C-53

31	32	33	34	35	36	37	38
39	40	41	42	43	44	45	46

F-26

1	2	3	4
5	6	7	8
9			

F-29

1	2
3	4
5	6

TSB Revision

**SUPPLEMENTAL RESTRAINT SYSTEM (SRS) CIRCUIT  
(UP TO 1993 MODEL)**

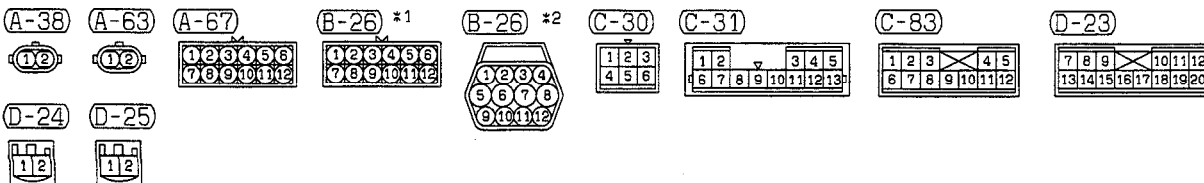
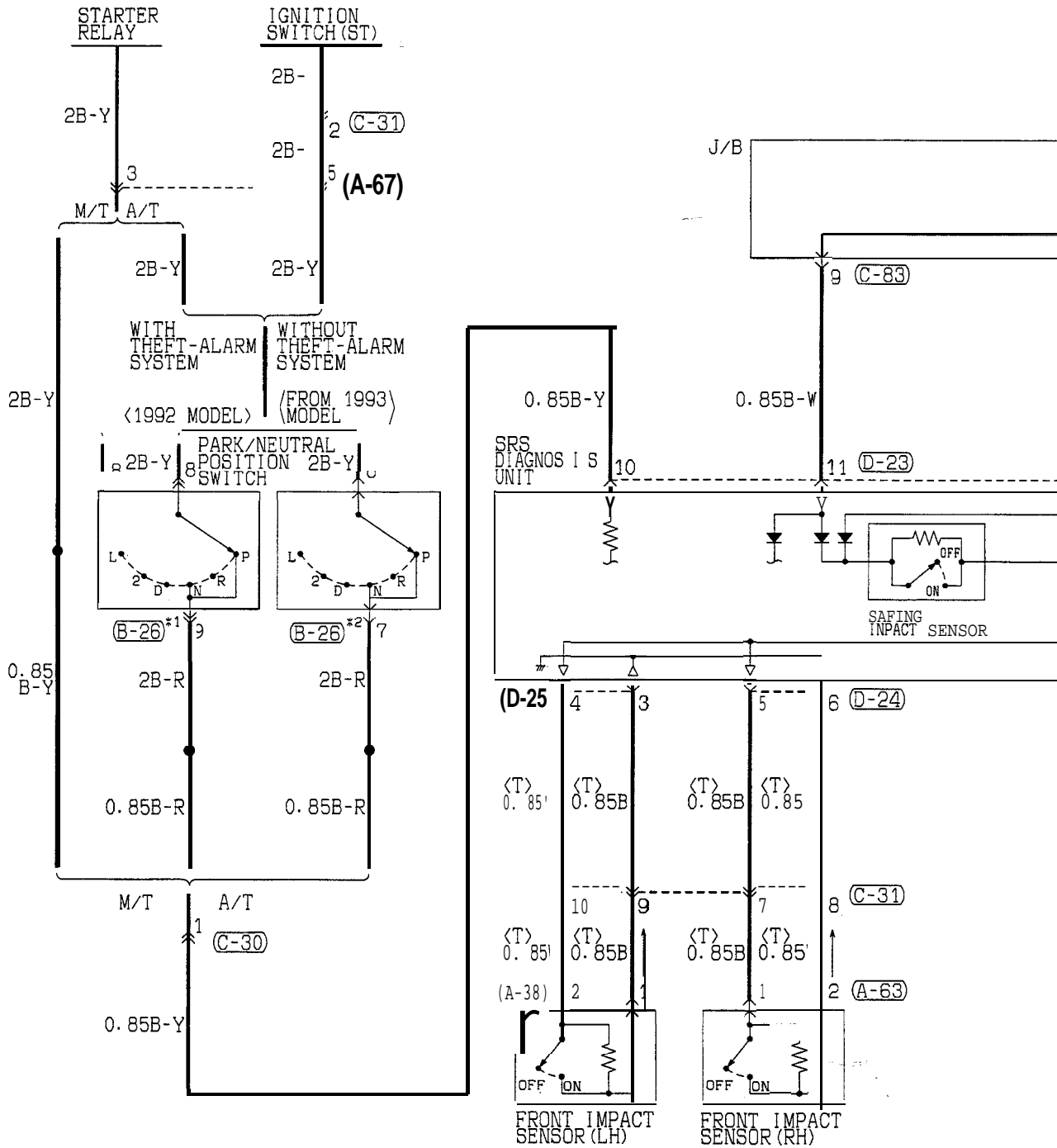

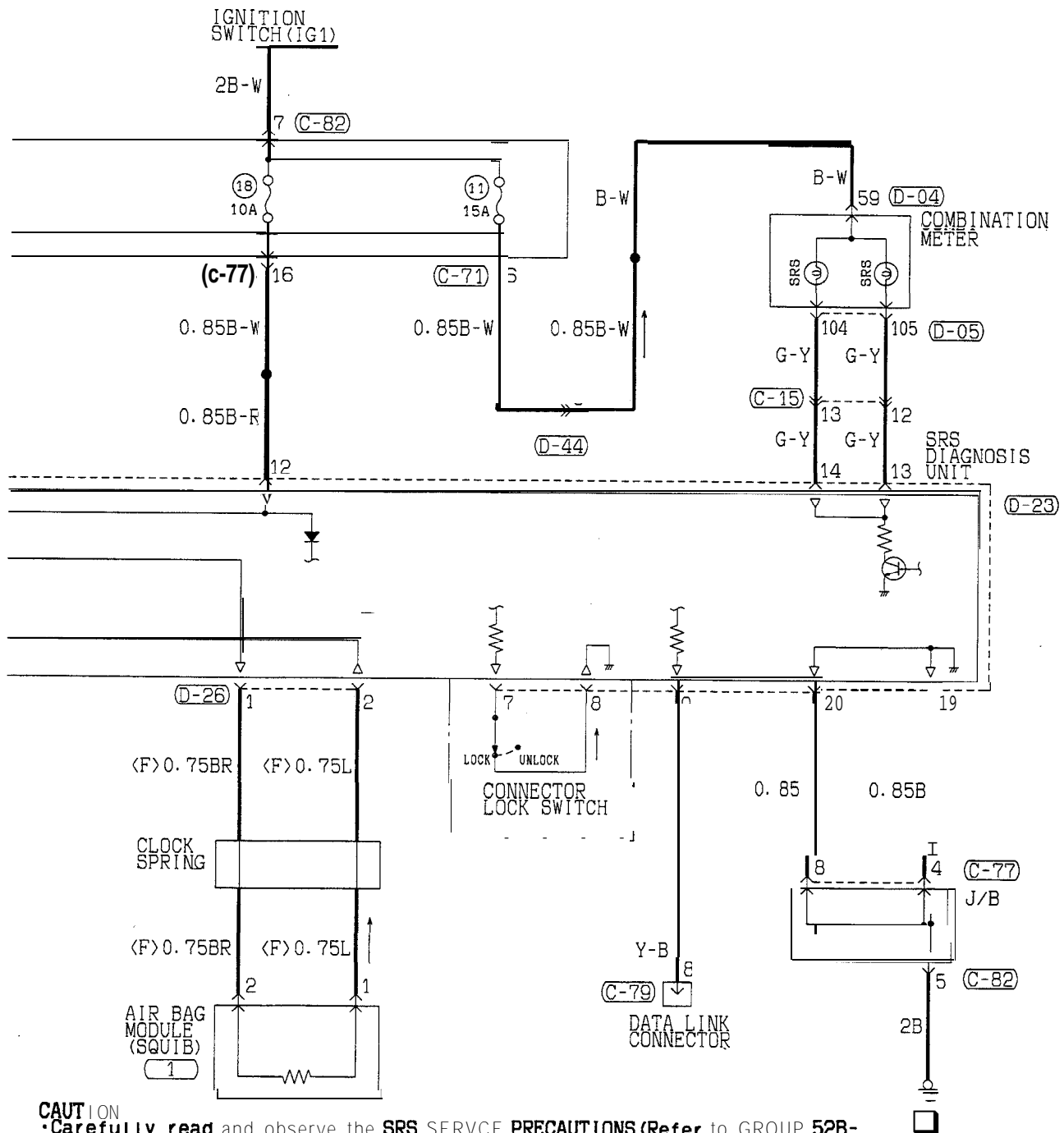

**CAUTION**  
 Carefully read and observe the SRS SERVICE PRECAUTIONS (Refer to GROUP 52B-Service Precautions) prior to any service.

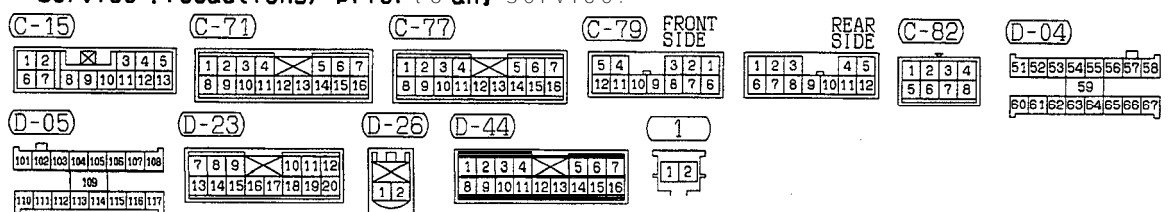

TSB Revision

# SUPPLEMENTAL RESTRAINT SYSTEM (SRS) CIRCUIT (FROM 1994 MODELS)

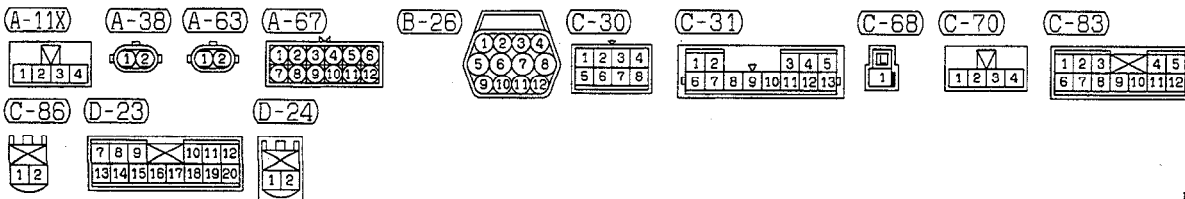
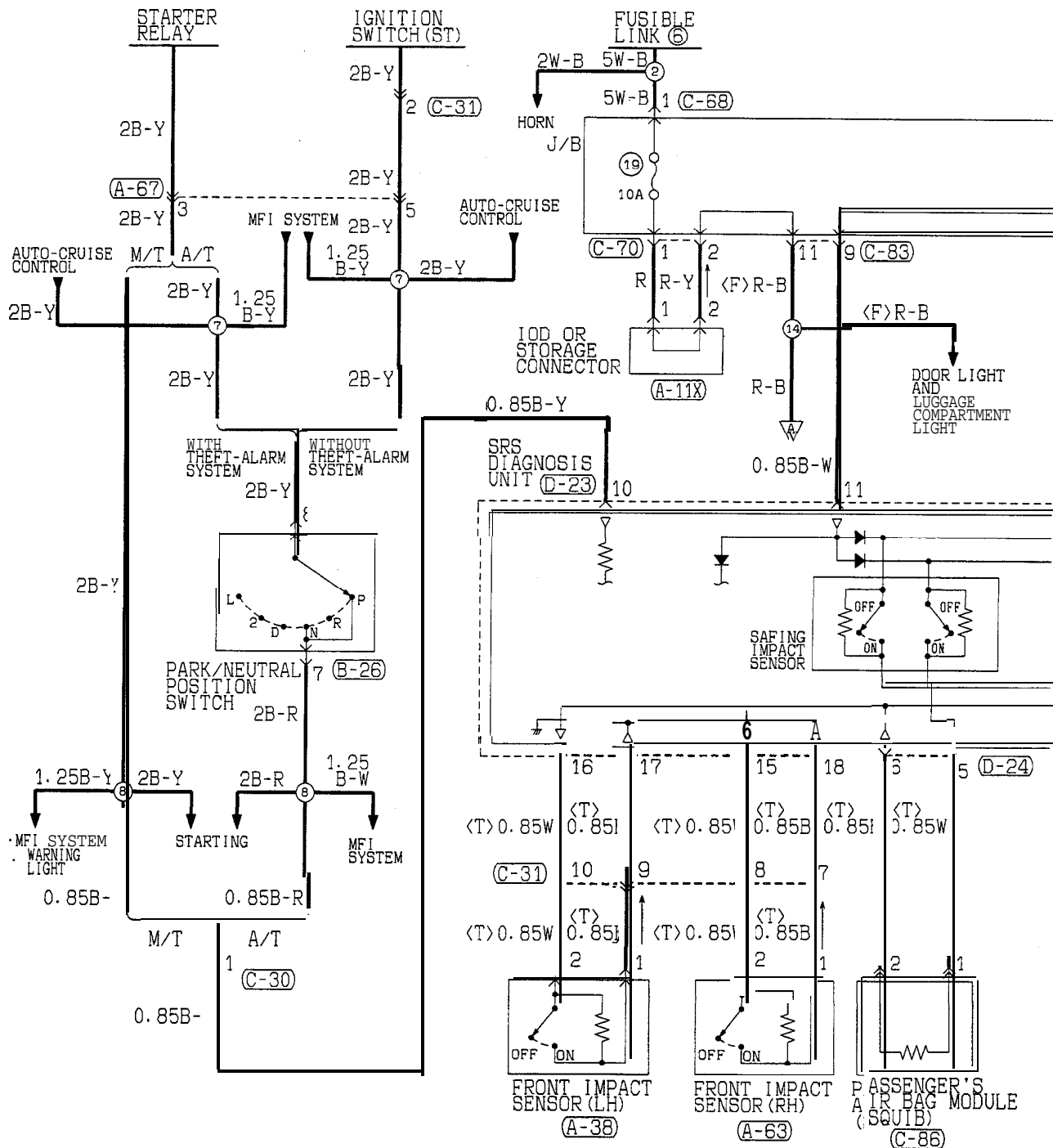

TSB Revision

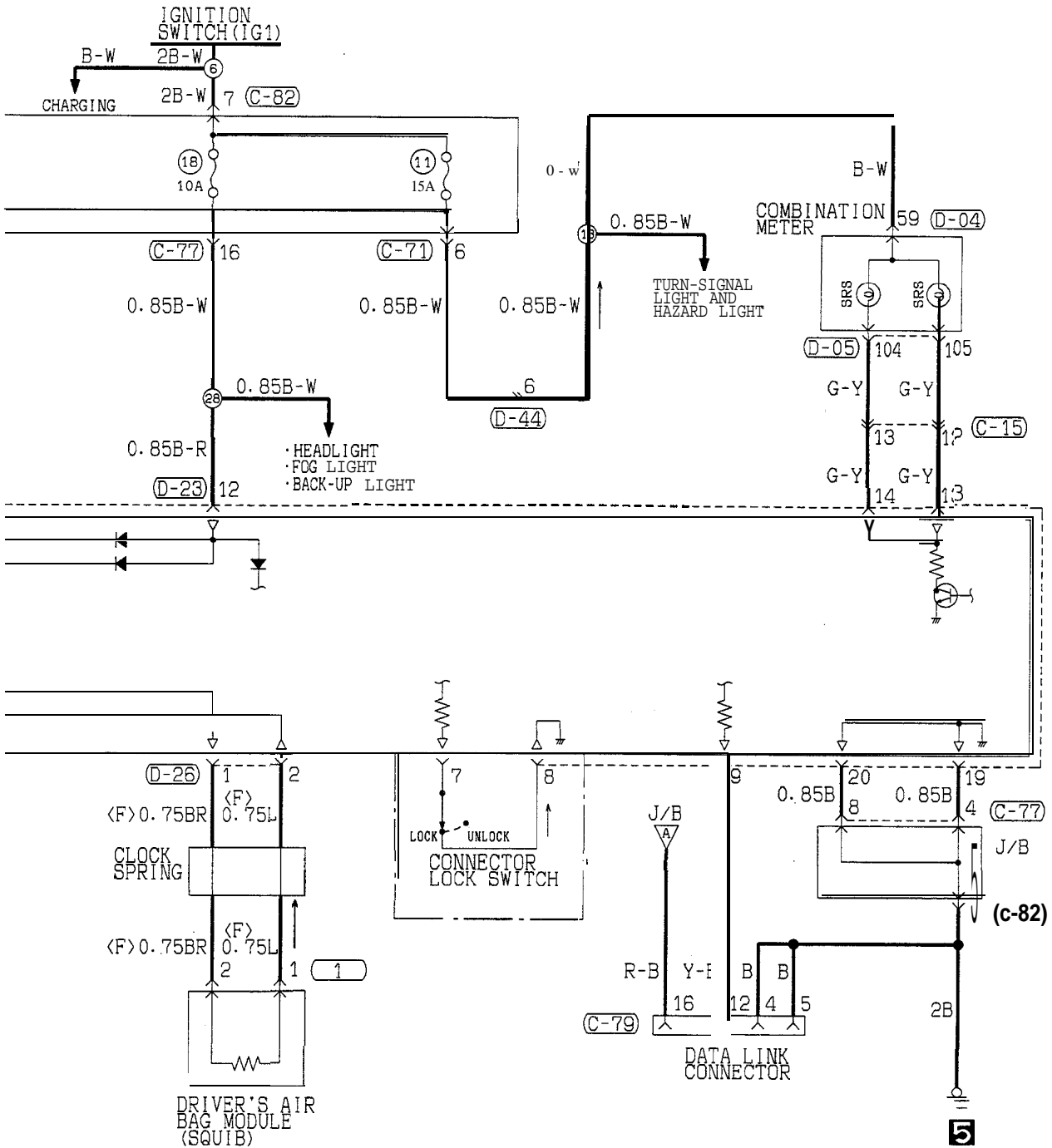

C-15

1	2	3	4	5
6	7	8	9	10
11	12	13		

C-71

1	2	3	4	5	6	7
8	9	10	11	12	13	14
15	16					

C-77

1	2	3	4	5	6	7
8	9	10	11	12	13	14
15	16					

C-79 FRONT SIDE (c-82) (D-04)

1	2	3	4	5	6	7	8
9	10	11	12	13	14	15	16

1	2	3	4
5	6	7	8

51	52	53	54	55	56	57	58
		59					
60	61	62	63	64	65	66	67

(D-05)

101	102	103	104	105	106	107	108
			109				
110	111	112	113	114	115	116	117

D-23

7	8	9	10	11	12
13	14	15	16	17	18
19	20				

D-26

1	2
---	---

D-44

1	2	3	4	5	6	7	8
9	10	11	12	13	14	15	16
17	18						

1

1	2
---	---



## COMPONENT LOCATION

Name	Symbol	Name	Symbol
Data link connector (from 1994 models)	D	Front impact sensor	A
Data link connector (up to 1993 models)	C	SRS diagnosis unit	B

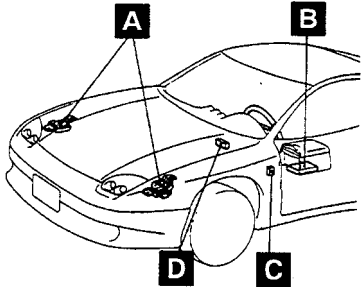

X19F0243

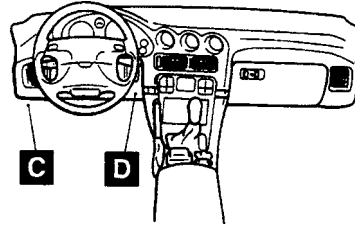

H19F0134  
00002691

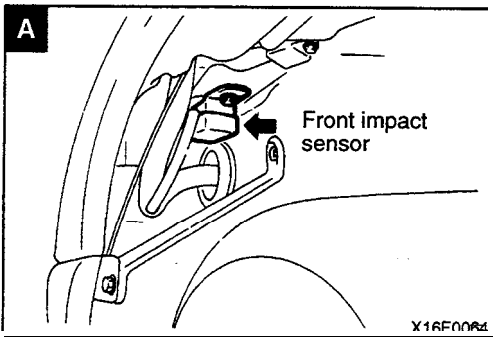

X16F0064

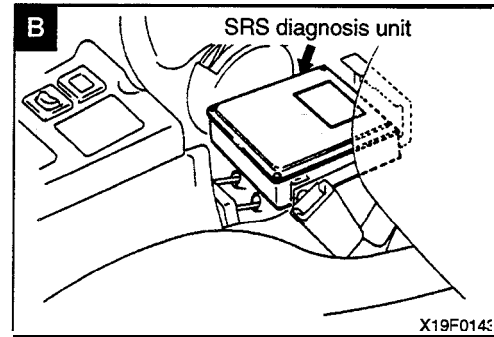

X19F0144

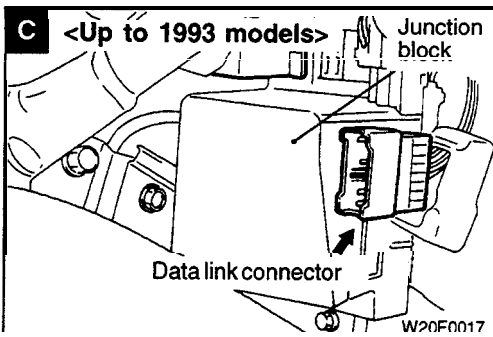

W20F0017

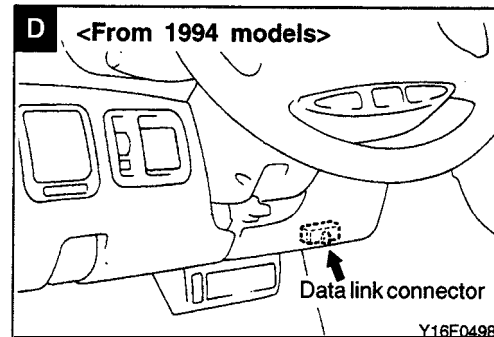

Y16F0498

# AUTO-CRUISE CONTROL

## COMPONENT LOCATION

Name	Symbol	Name	Symbol
Auto-cruise control unit	B	Data link connector (up to 1993 models)	D
Auto-cruise relay	C	Engine control module	C
Data link connector (from 1994 models)	E	Throttle position sensor	A

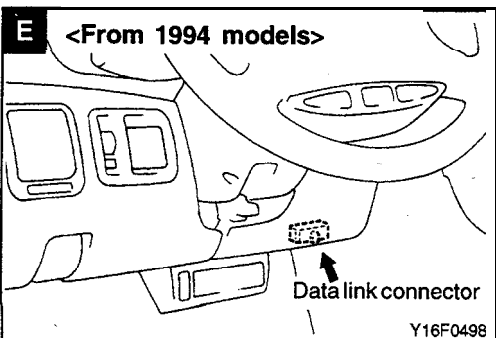
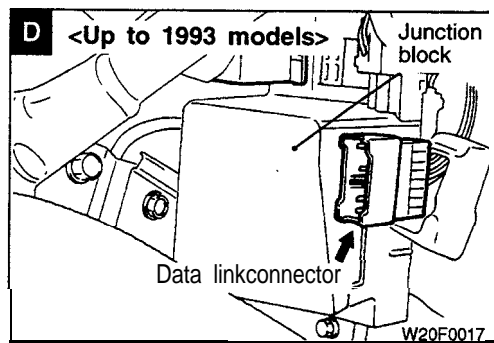
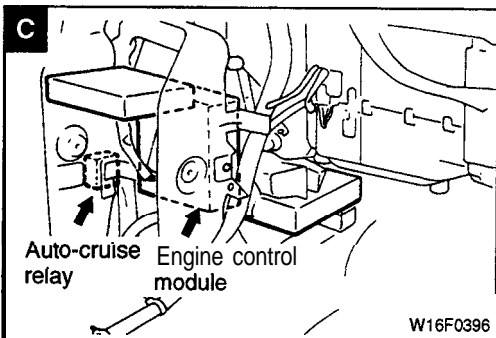
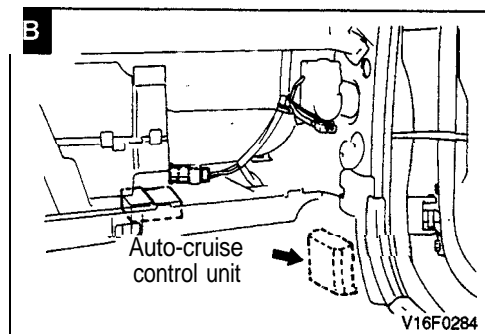
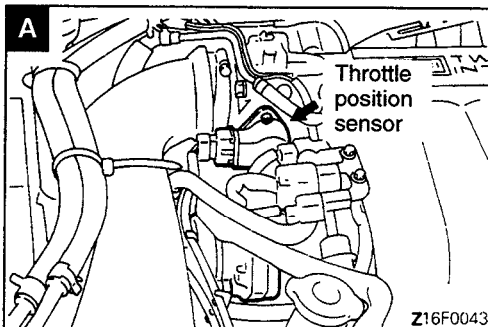
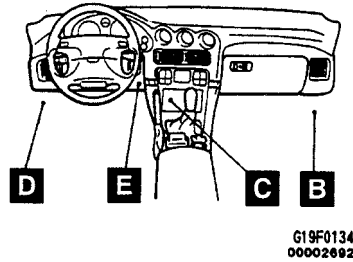
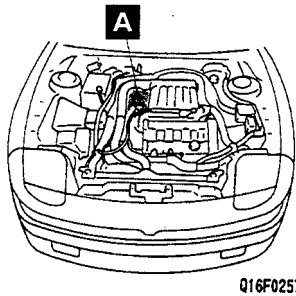

**AUTO-CRUISE CONTROL CIRCUIT (UP TO 1993 MODELS)**

<M/T>

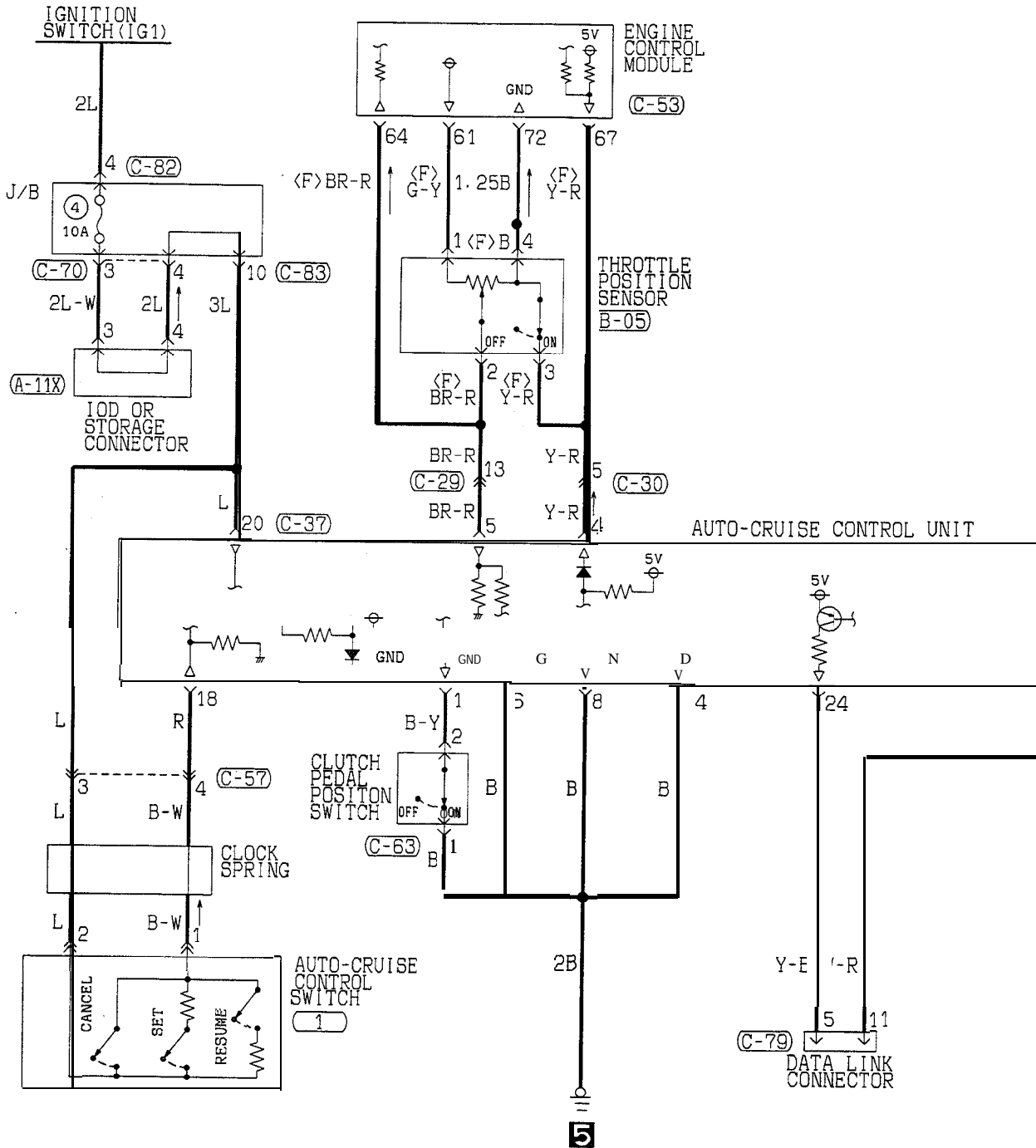

- (A-11X)  

M
1 2 3 4
- (B-05)  

1 2 3 4
---------
- (C-29)  

1 2 3 4	5 6 7 8
9 10 11 12	13 14 15 16 17 18 19
- (C-30)  

1 2 3
4 5 6
- (C-37)  

1 2 3 4 5 6 7 8 9 10 11 12 13
14 15 16 17 18 19 20 21 22 23 24 25 26
- (C-53)  

1 2 3 4 5 6 7 8 9 10 11
12 13 14 15 16 17 18 19 20 21 22
- (C-57)  

M
1 2 3 4
- (C-63)  

1
2
- (C-70)  

M
1 2 3 4
- (C-79) FRONT SIDE  

5 4	3 2 1
12 11 10 9	8 7 6
- (C-79) REAR SIDE  

1 2 3	4 5
6 7 8	9 10 11 12
- (C-82)  

1 2 3 4
5 6 7 8
- (C-83)  

1 2 3	4 5
6 7 8	9 10 11 12
- (1)  

1 2
-----

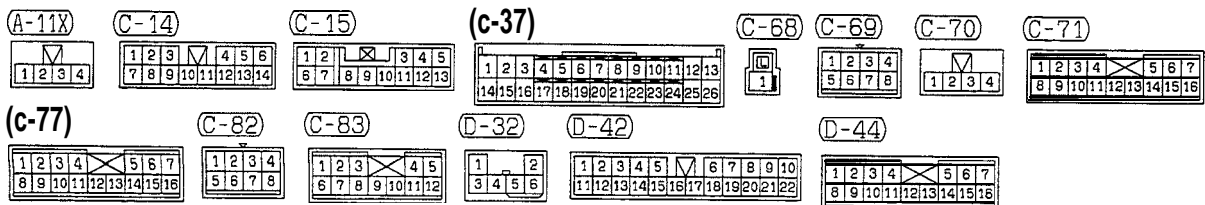
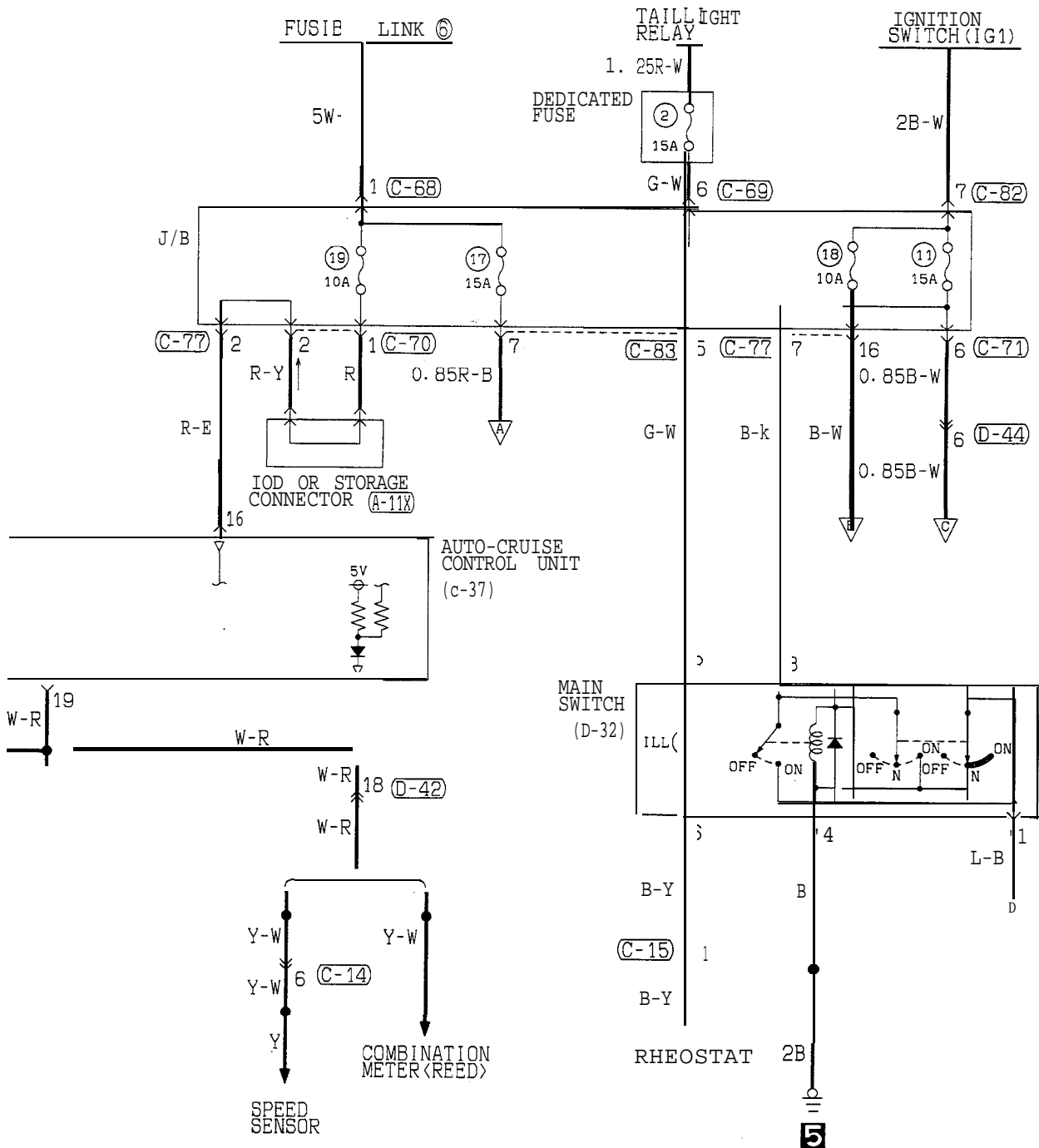

TSB Revision

AUTO-CRUISE CONTROL CIRCUIT (UP TO 1993 MODELS) <M/T> (CONTINUED)

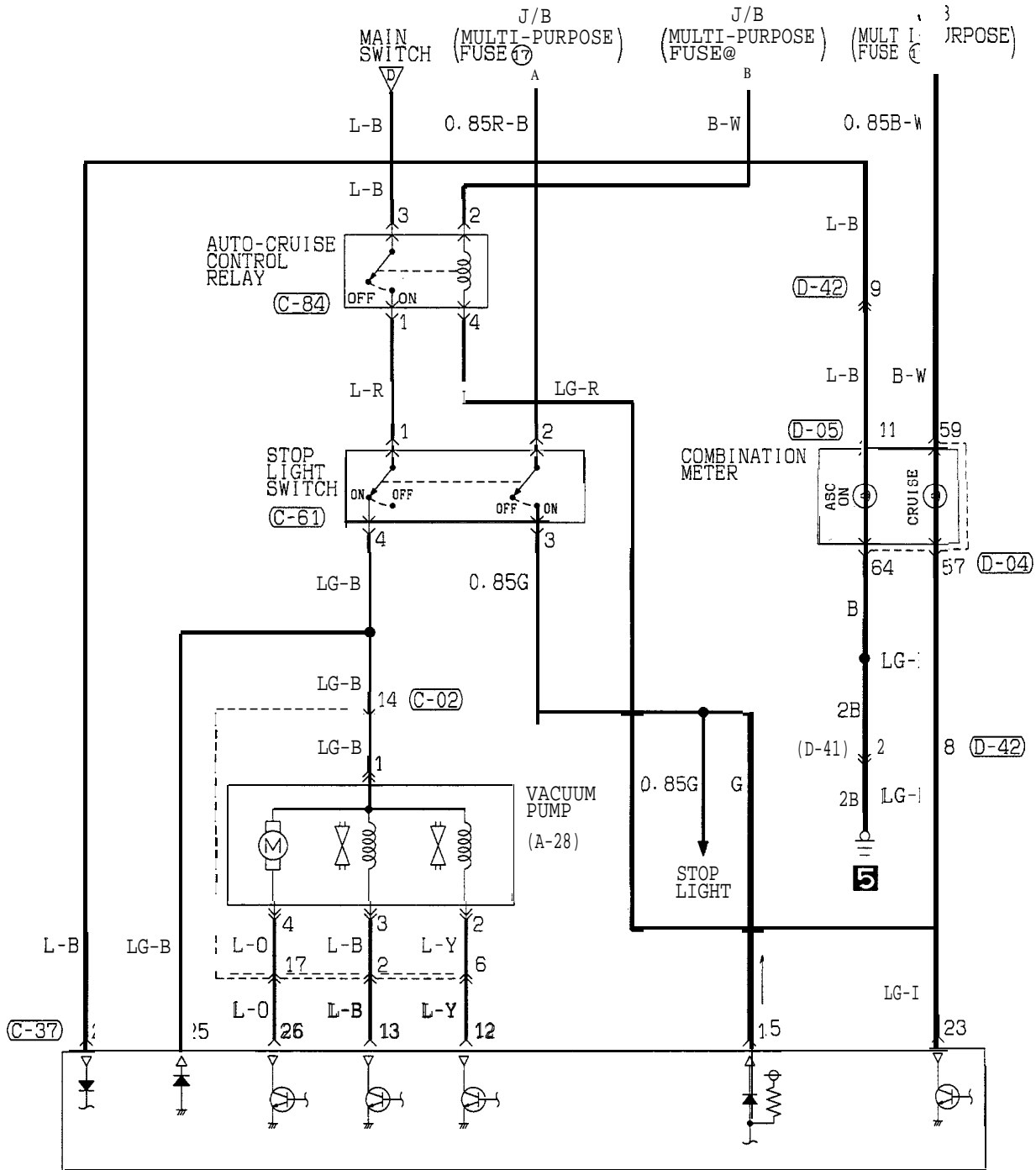

AUTO-CRUISE CONTROL UNIT

(A-28) (C-02)

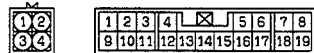

(C-37)

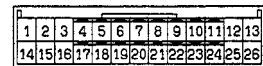

(C-61) (C-84)



(D-04)

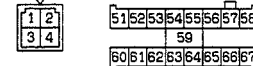

(D-05)

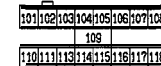

(D-42)



---

NOTES

**AUTO-CRUISE CONTROL CIRCUIT (1994, 1995 MODELS)**

<M/T> NON TURBO (FEDERAL)

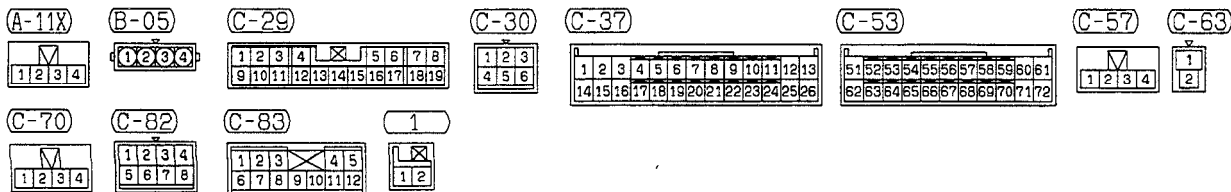
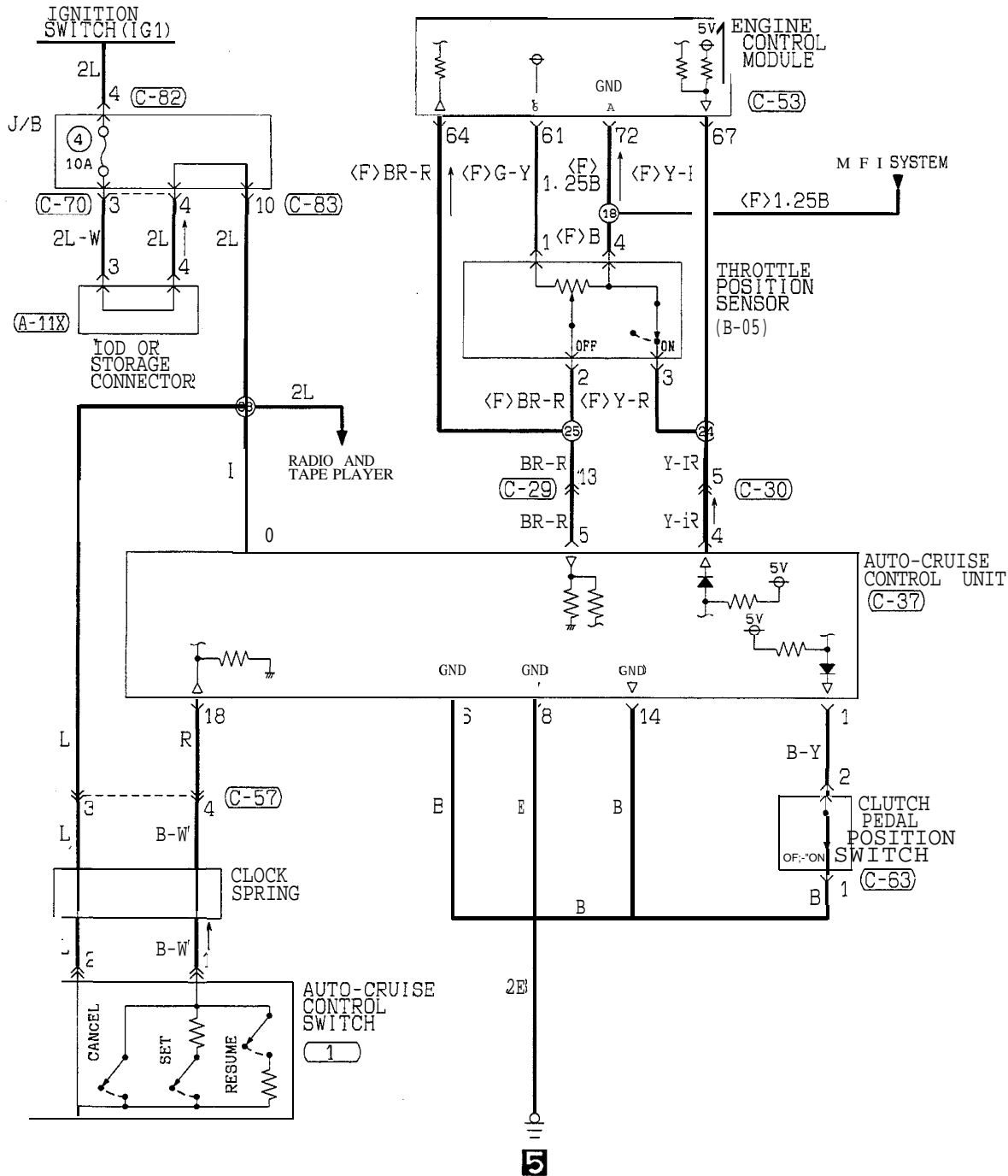

TSB Revision

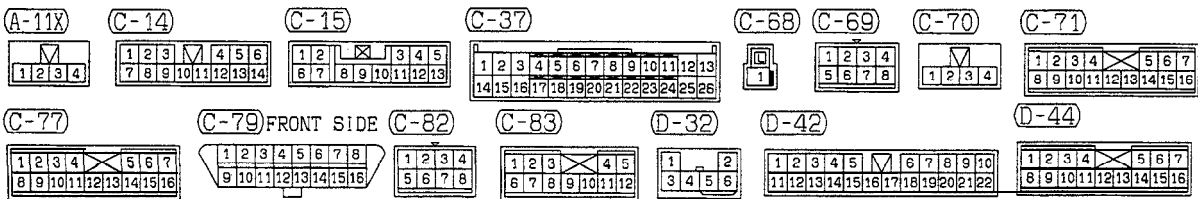
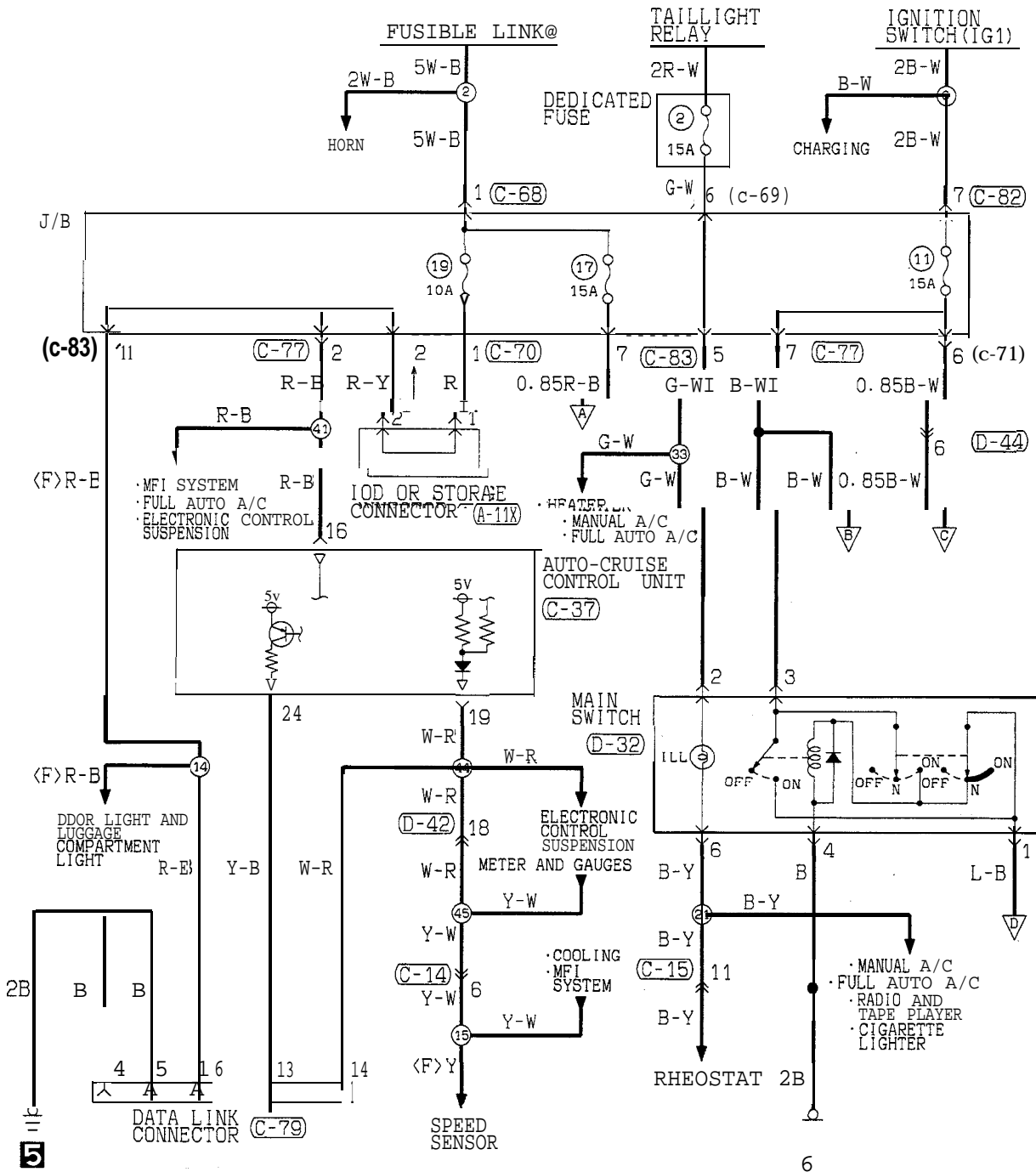

HR15M20AB

TSB Revision



**AUTO-CRUISE CONTROL CIRCUIT (1994, 1995 MODELS) <M/T> NON TURBO (FEDERAL) (CONTINUED)**

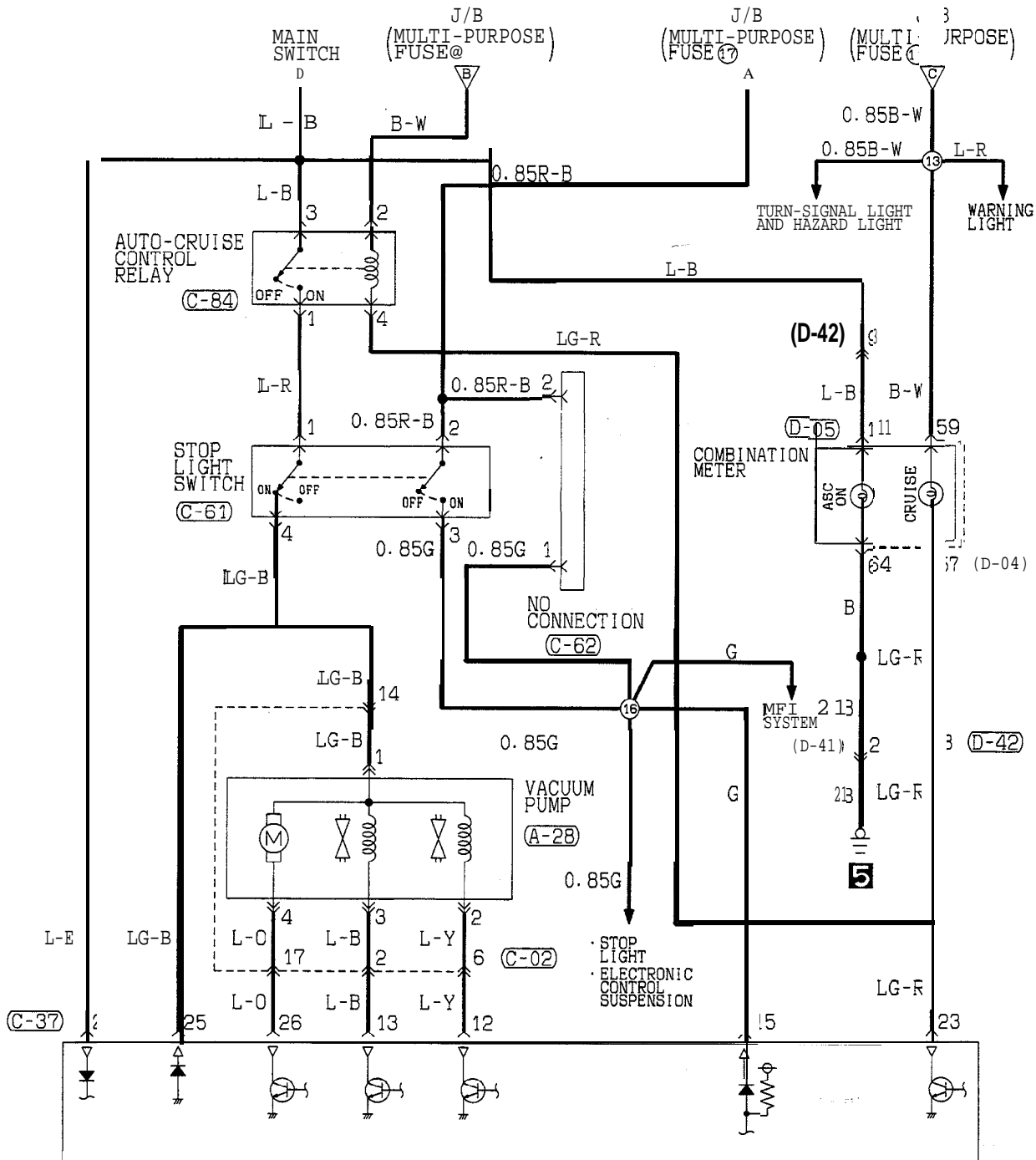

AUTO-CRUISE CONTROL UNIT

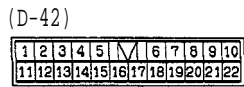
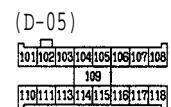
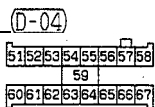
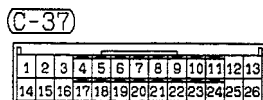
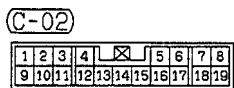

TSB Revision

---

NOTES

**AUTO-CRUISE CONTROL CIRCUIT (1994, 1995 MODELS)**

<M/T> TURBO, NON TURBO (CALIFORNIA)

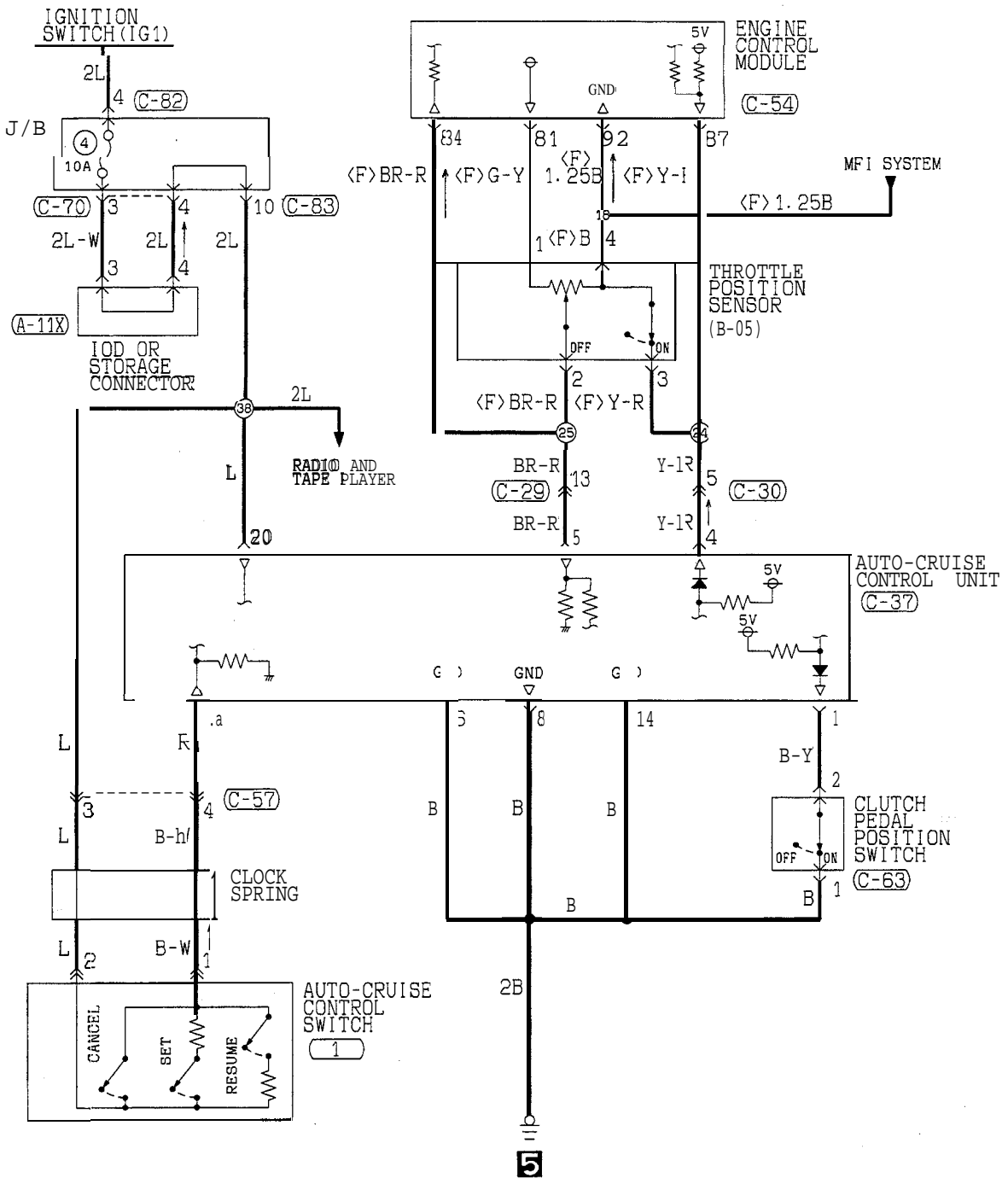

- (A-11X) 

M
1 2 3 4
- (B-05) 

1 2 3 4
---------
- (c-29) 

1	2	3	4	5	6	7	8			
9	10	11	12	13	14	15	16	17	18	19
- (C-30) 

1	2	3
4	5	6
- (C-37) 

1	2	3	4	5	6	7	8	9	10	11	12	13
14	15	16	17	18	19	20	21	22	23	24	25	26
- (C-54) 

71	72	73	74	75	76	77	78	79	80	81
82	83	84	85	86	87	88	89	90	91	92
- (C-57) 

M
1 2 3 4
- (C-63) 

1
---
- (C-70) 

M
1 2 3 4
- (C-82) 

1	2	3	4
5	6	7	8
- (C-83) 

1	2	3	4	5		
6	7	8	9	10	11	12
- 1 

1	2
---	---

TSB Revision

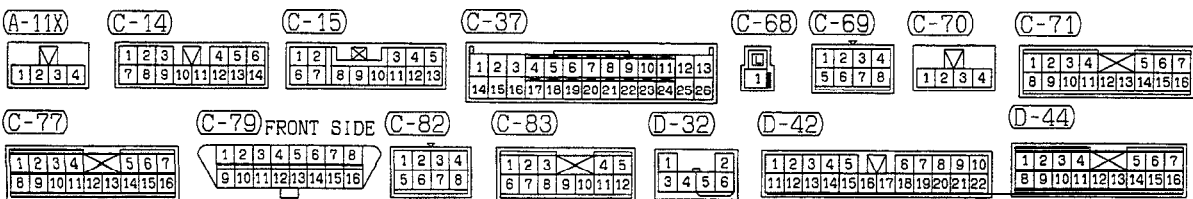
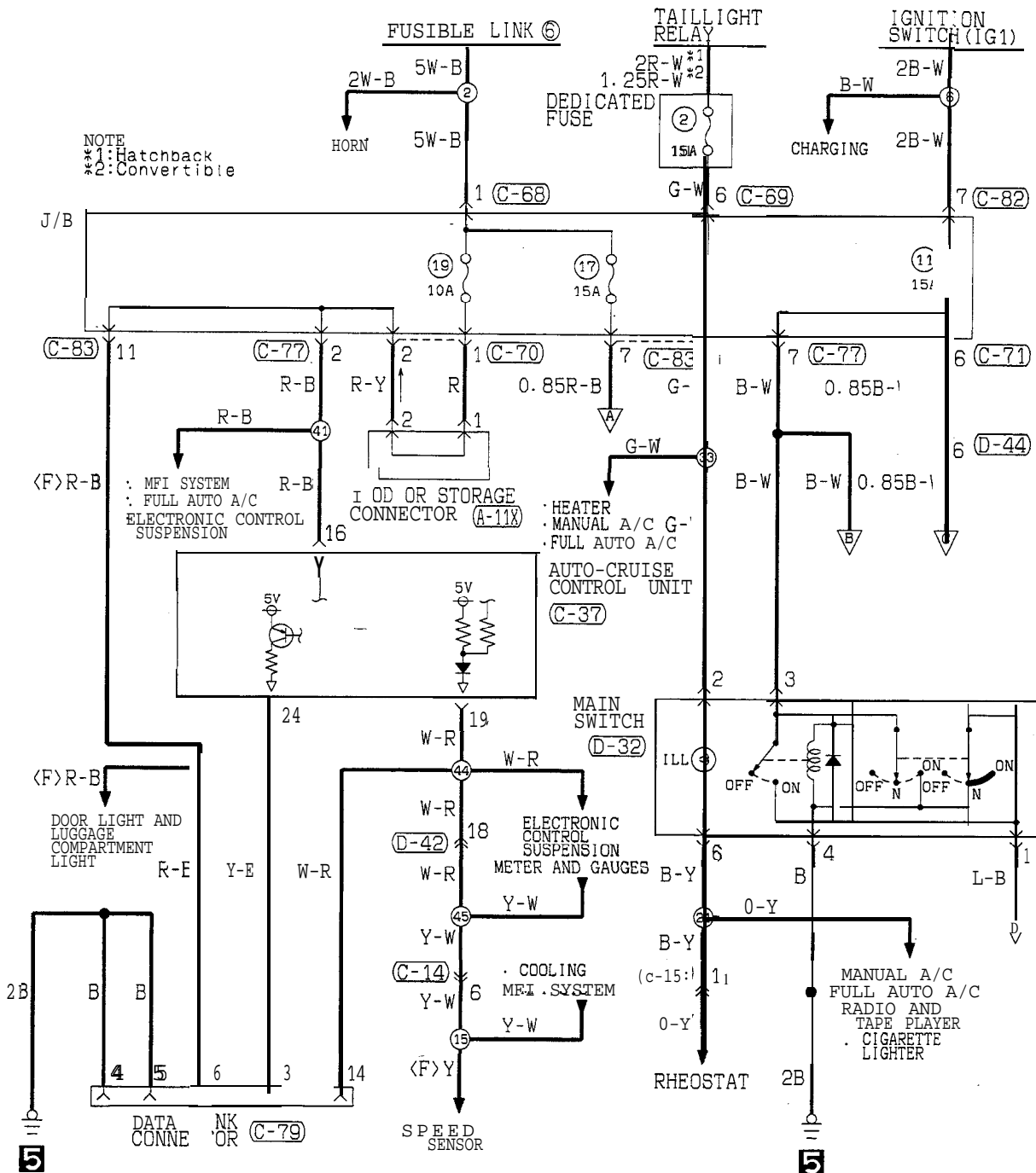

**AUTO-CRUISE CONTROL CIRCUIT (1994, 1995 MODELS) <M/T> TURBO, NON TURBO (CALIFORNIA) (CONTINUED)**

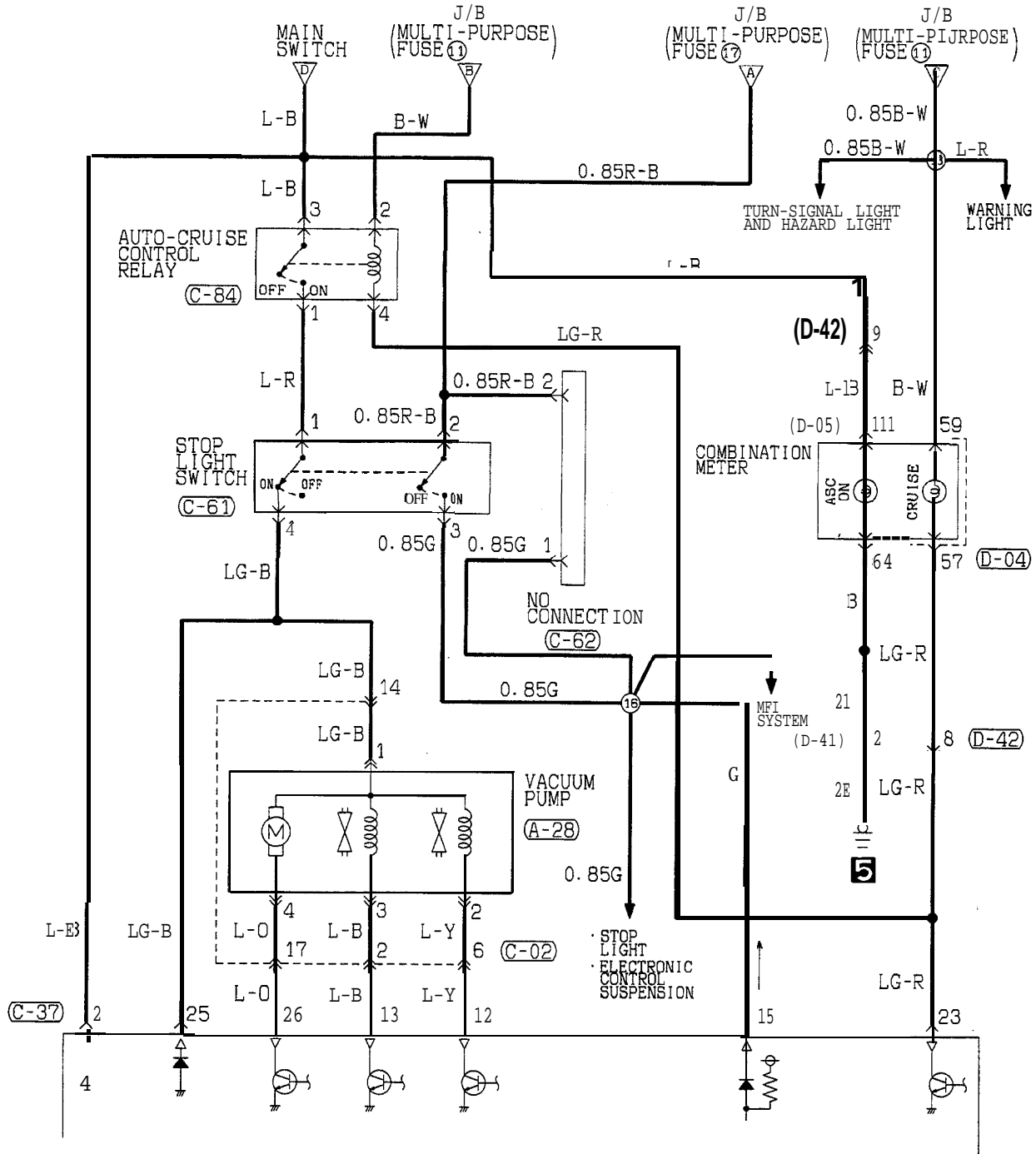

AUTO-CRUISE CONTROL UNIT

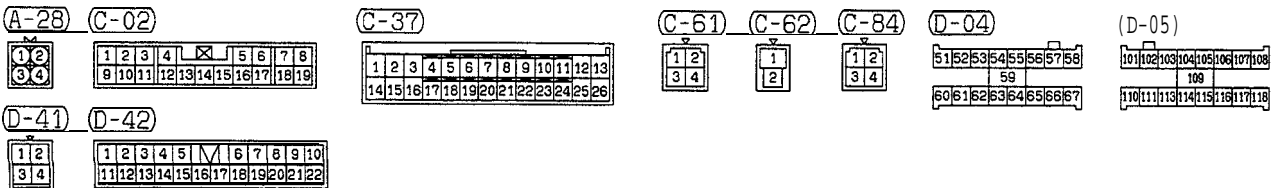

TSB Revision

---

NOTES

**AUTO-CRUISE CONTROL CIRCUIT (FROM 1996 MODELS)**

<M/T>

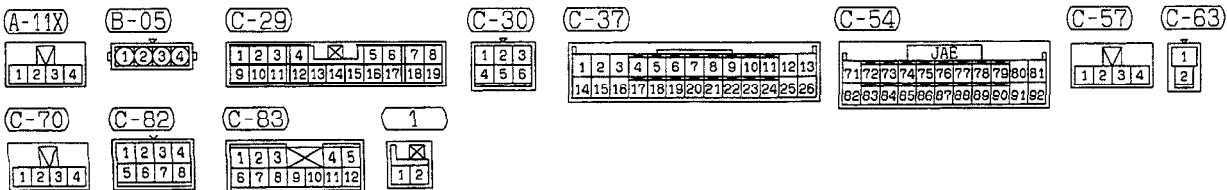
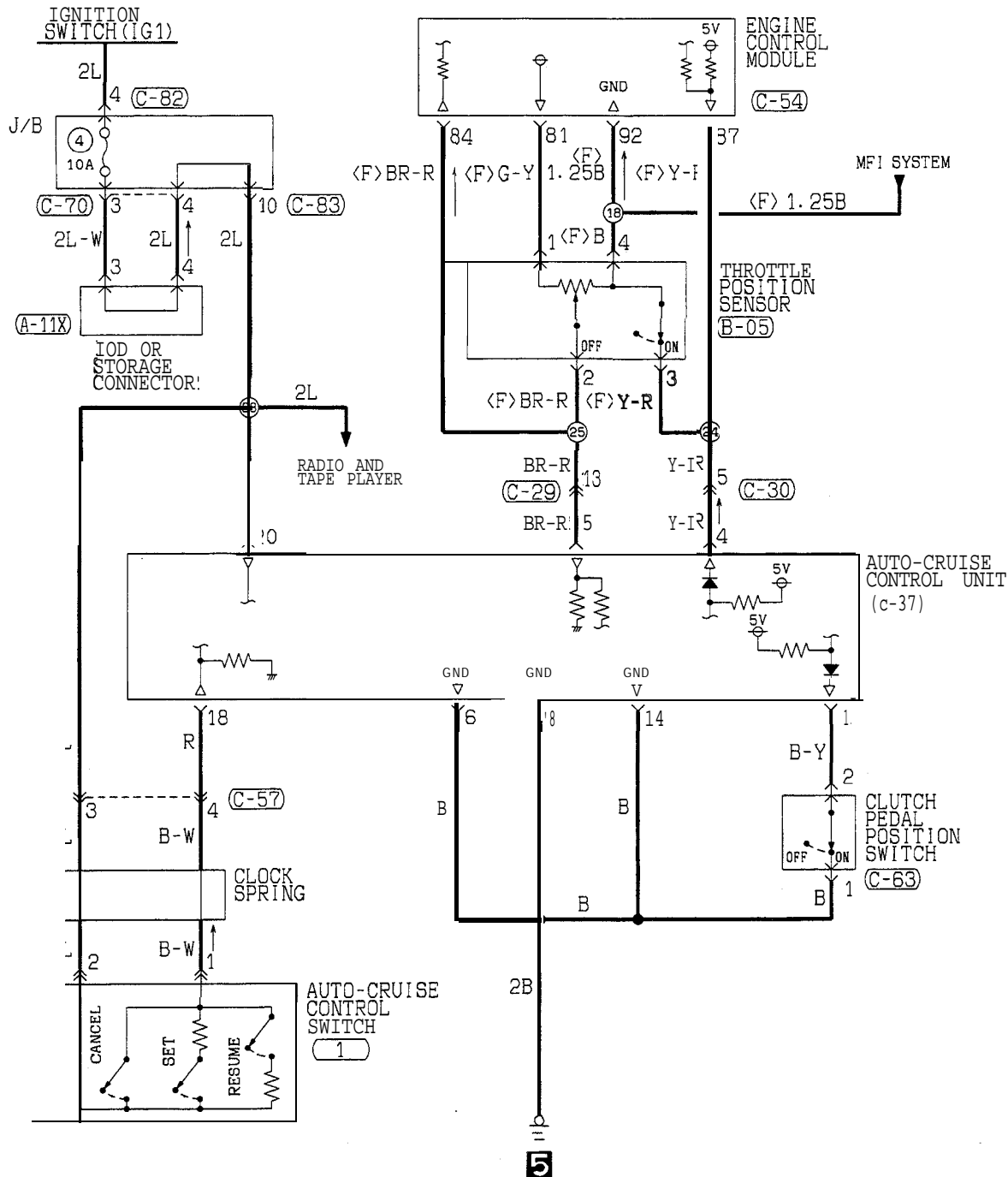

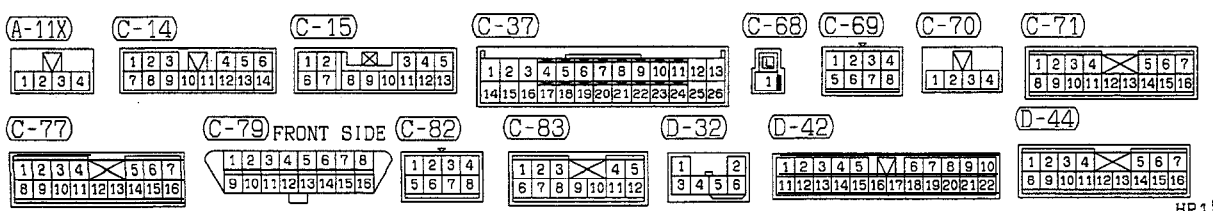
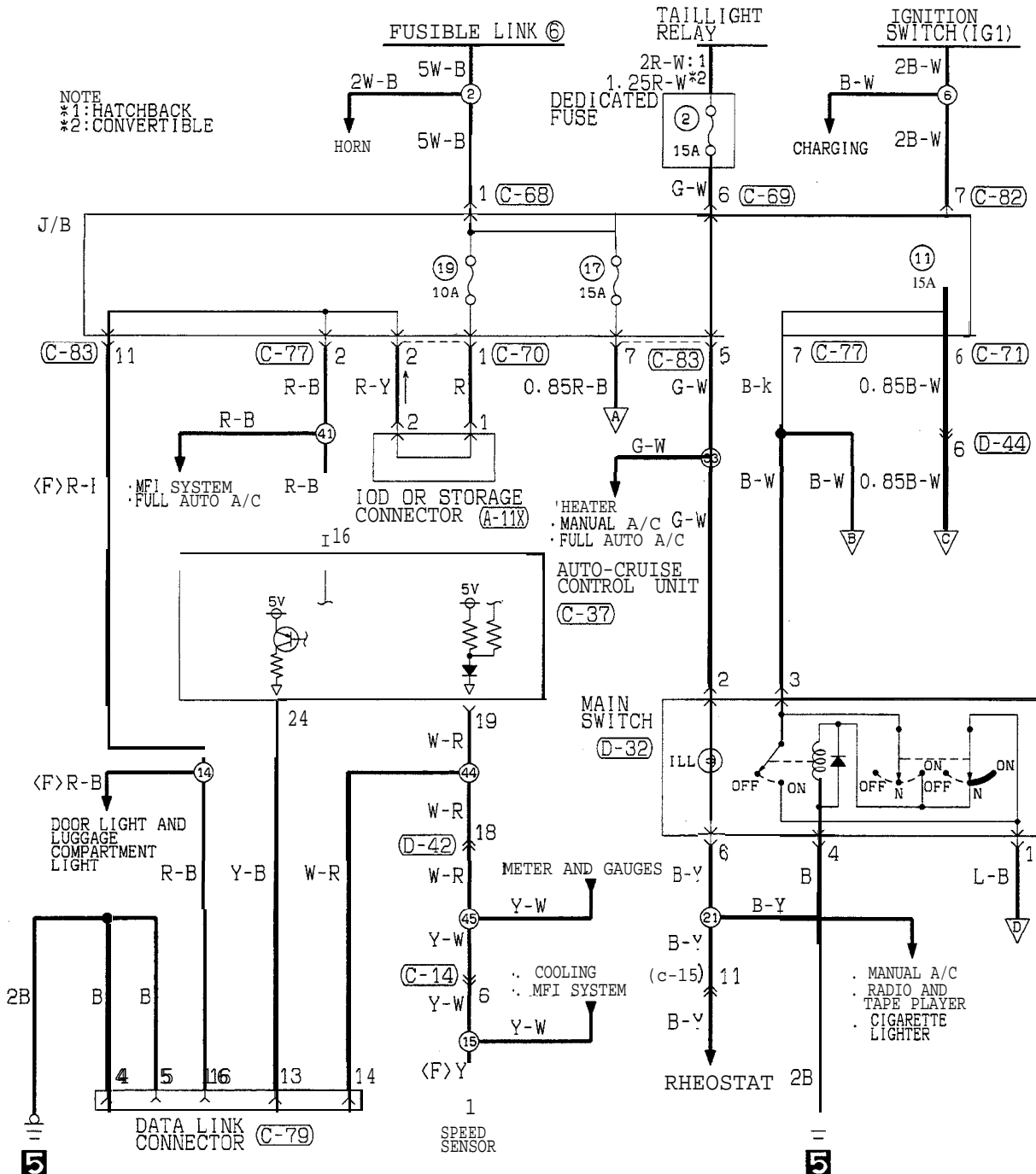

HR 1 5M36AB

TSB Revision



AUTO-CRUISE CONTROL CIRCUIT (FROM 1996 MODELS) <M/T> (CONTINUED)

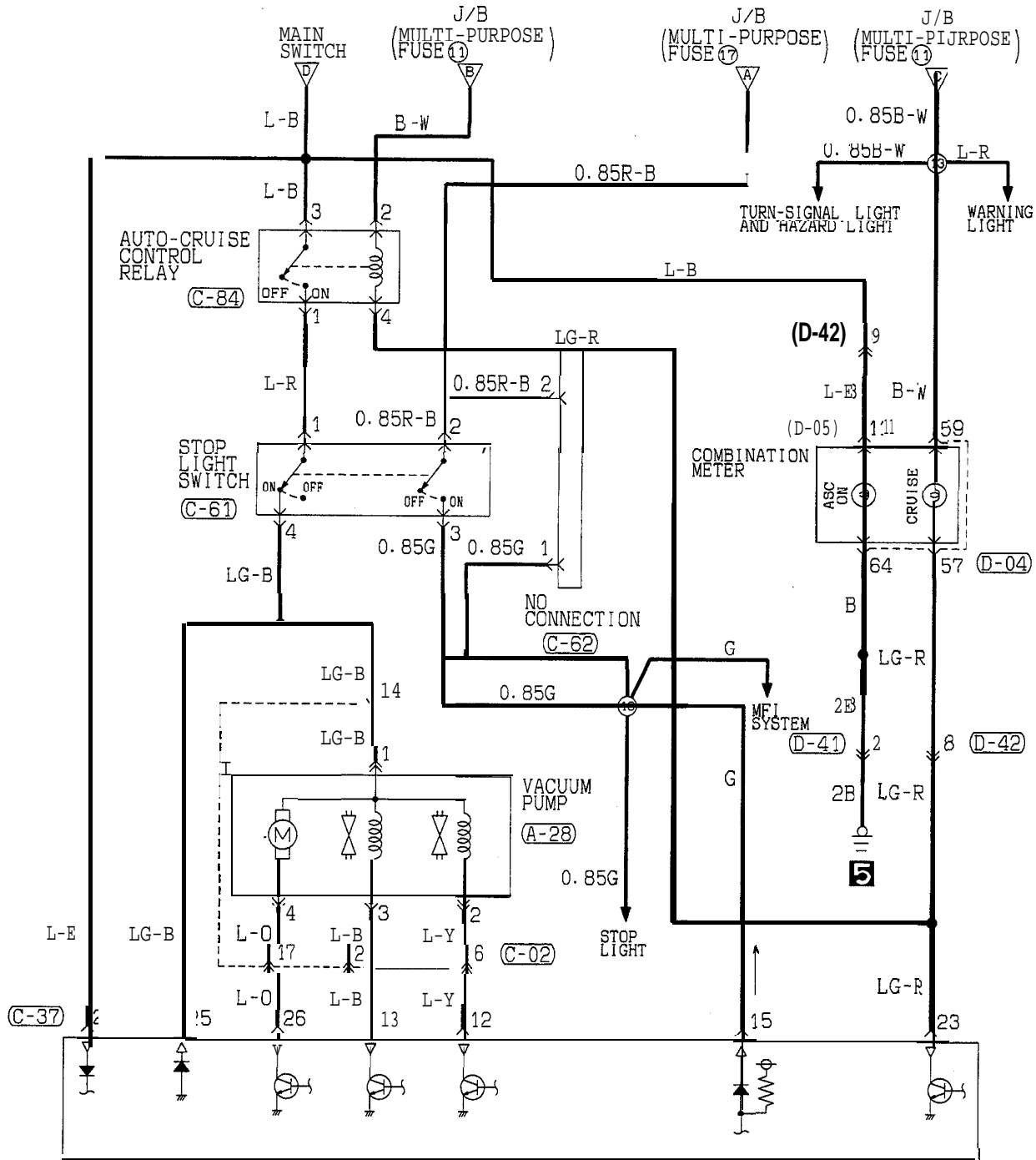

AUTO-CRUISE CONTROL UNIT

- A-28**  

1	2
3	4
- C-02**  

1	2	3	4	5	6	7	8			
9	10	11	12	13	14	15	16	17	18	19
- C-37**  

1	2	3	4	5	6	7	8	9	10	11	12	13
14	15	16	17	18	19	20	21	22	23	24	25	26
- C-61**  

1	2
3	4
- C-62**  

1
2
- C-84**  

1	2
3	4
- D-04**  

5	1	2	3	4	5	6	7	8	
9	10	11	12	13	14	15	16	17	18
19	20	21	22	23	24	25	26	27	28
- D-05**  

1	2	3	4	5	6	7	8	9	10
11	12	13	14	15	16	17	18	19	20
21	22	23	24	25	26	27	28	29	30
- D-41**  

1	2
3	4
- D-42**  

1	2	3	4	5	6	7	8	9	10		
11	12	13	14	15	16	17	18	19	20	21	22

---

NOTES

**AUTO-CRUISE CONTROL CIRCUIT (1992 MODEL)**

<A/T>

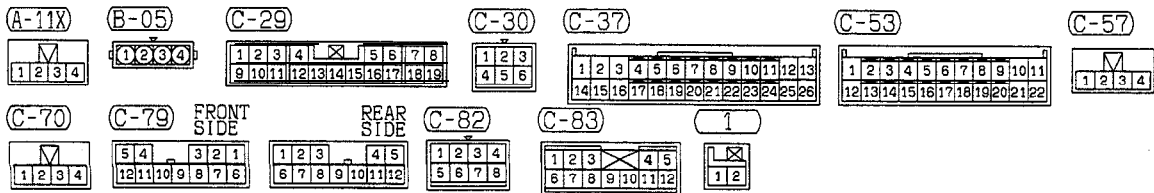
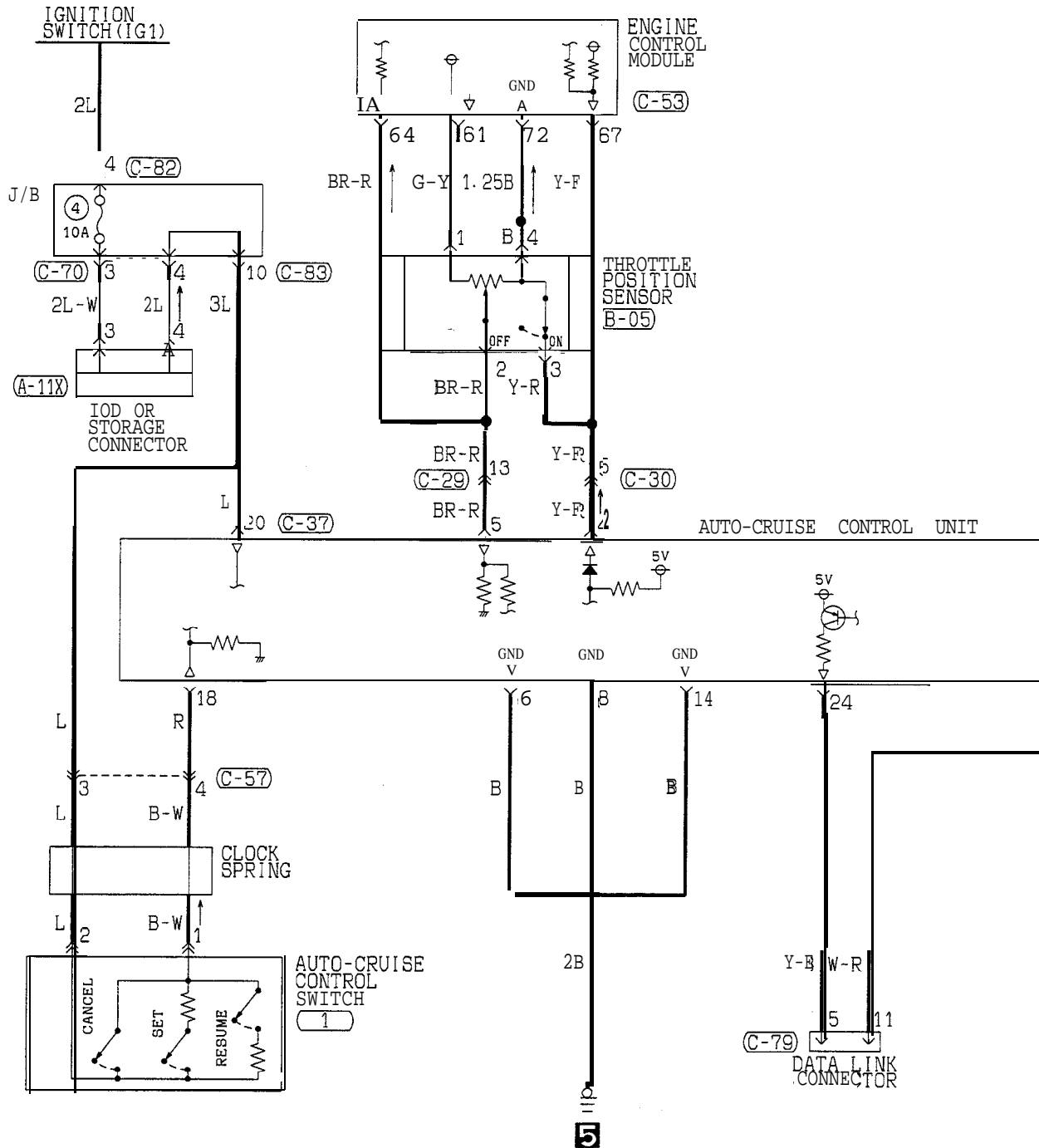

TSB Revision

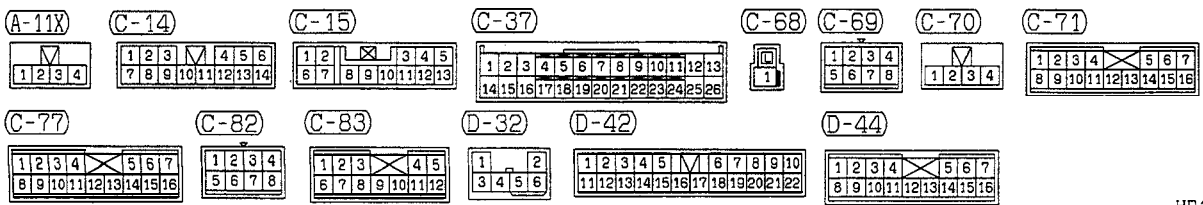
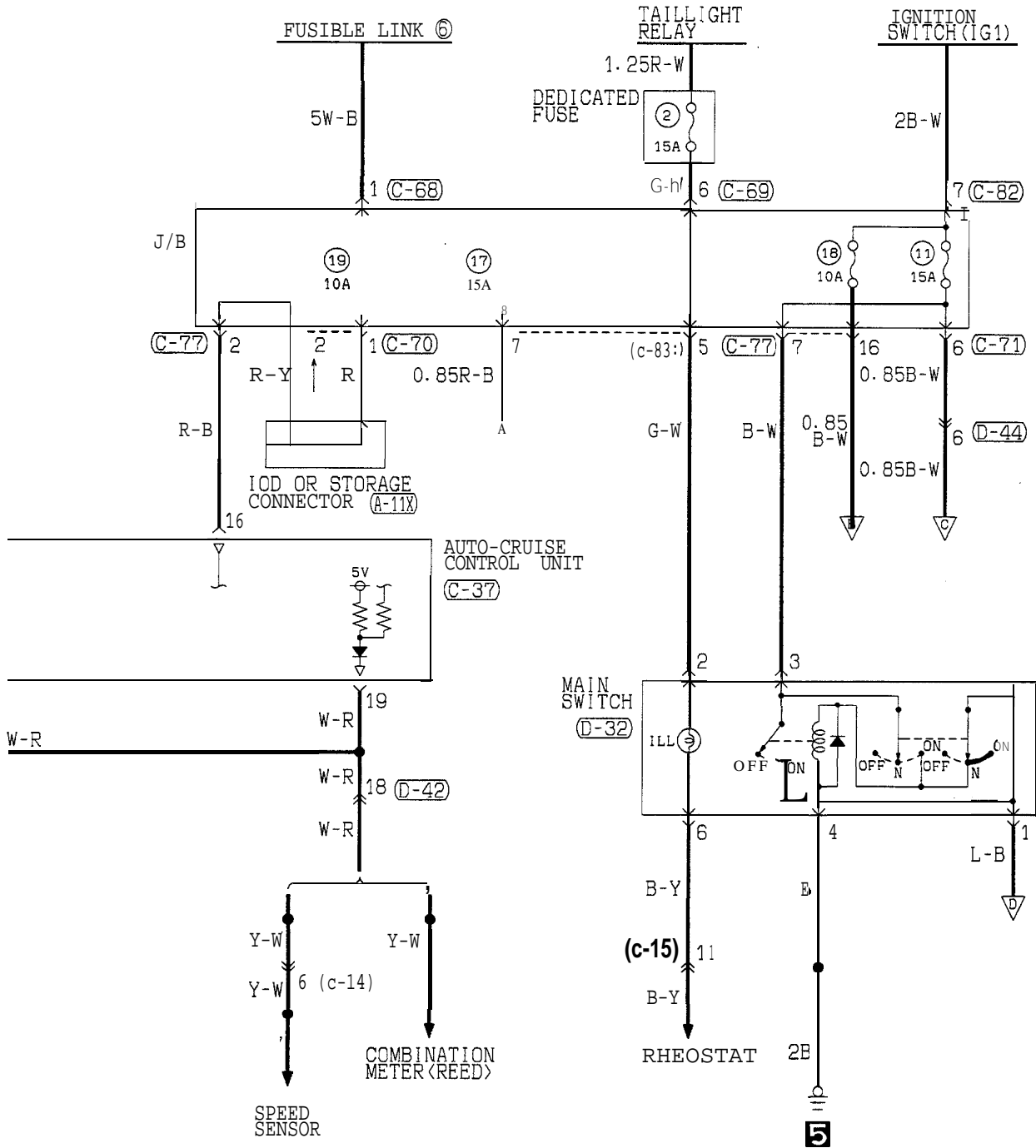

HR15M22AB

TSB Revision

AUTO-CRUISE CONTROL CIRCUIT (1992 MODEL) <A/T> (CONTINUED)

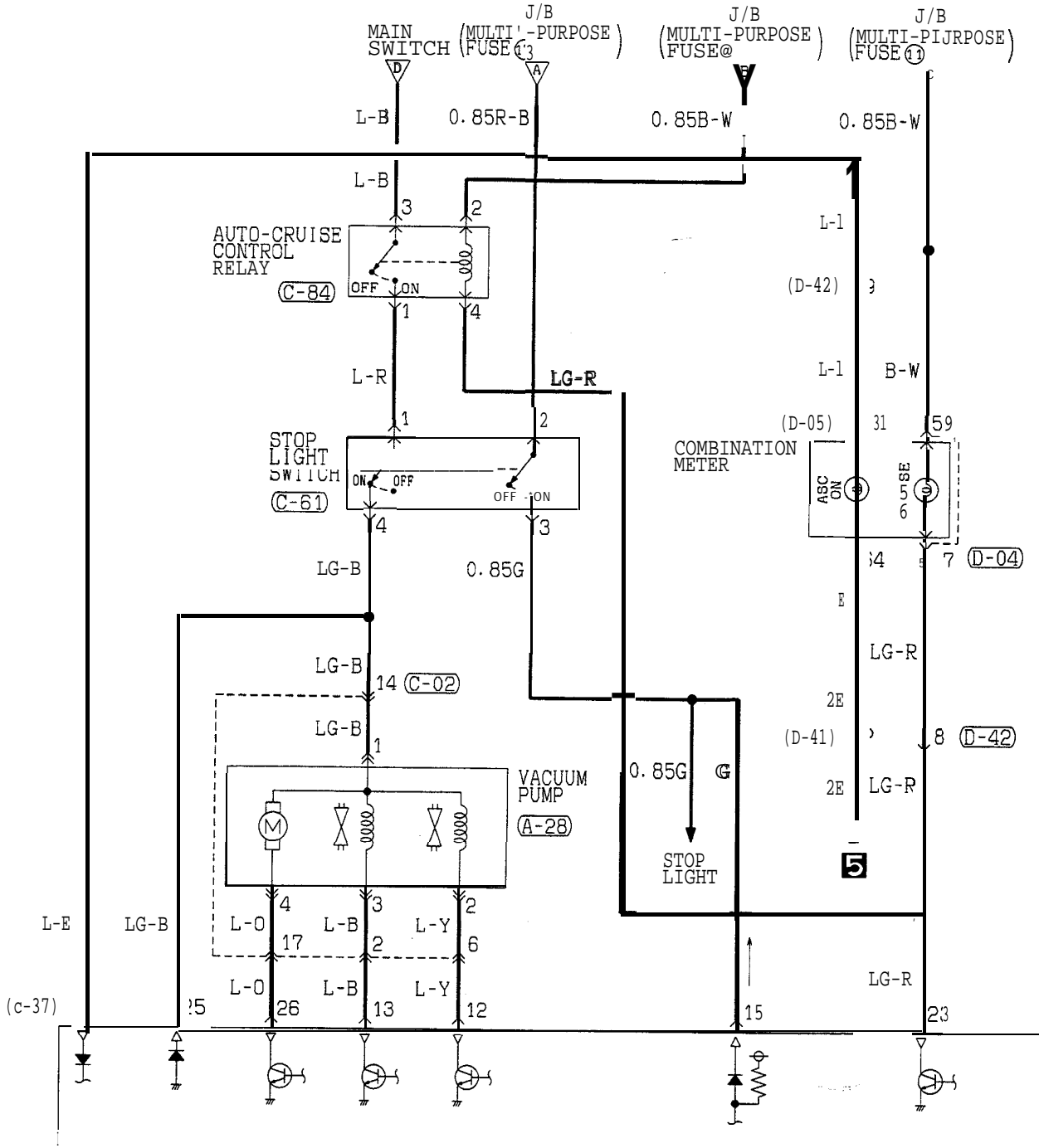

AUTO-CRUISE CONTROL UNIT

(A-28) (C-02)

1	2	3	4	5	6	7	8
9	10	11	12	13	14	15	16
17	18	19					

(C-37)

1	2	3	4	5	6	7	8	9	10	11	12	13
14	15	16	17	18	19	20	21	22	23	24	25	26

(C-61) (C-84)

1	2
3	4

(D-04)

51	52	53	54	55	56	57	58
59							
60	61	62	63	64	65	66	67

(D-05)

101	102	103	104	105	106	107	108
109							
110	111	113	114	115	116	117	118

(D-42)

1	2	3	4	5	6	7	8	9	10
11	12	13	14	15	16	17	18	19	20
21	22								

TSB Revision

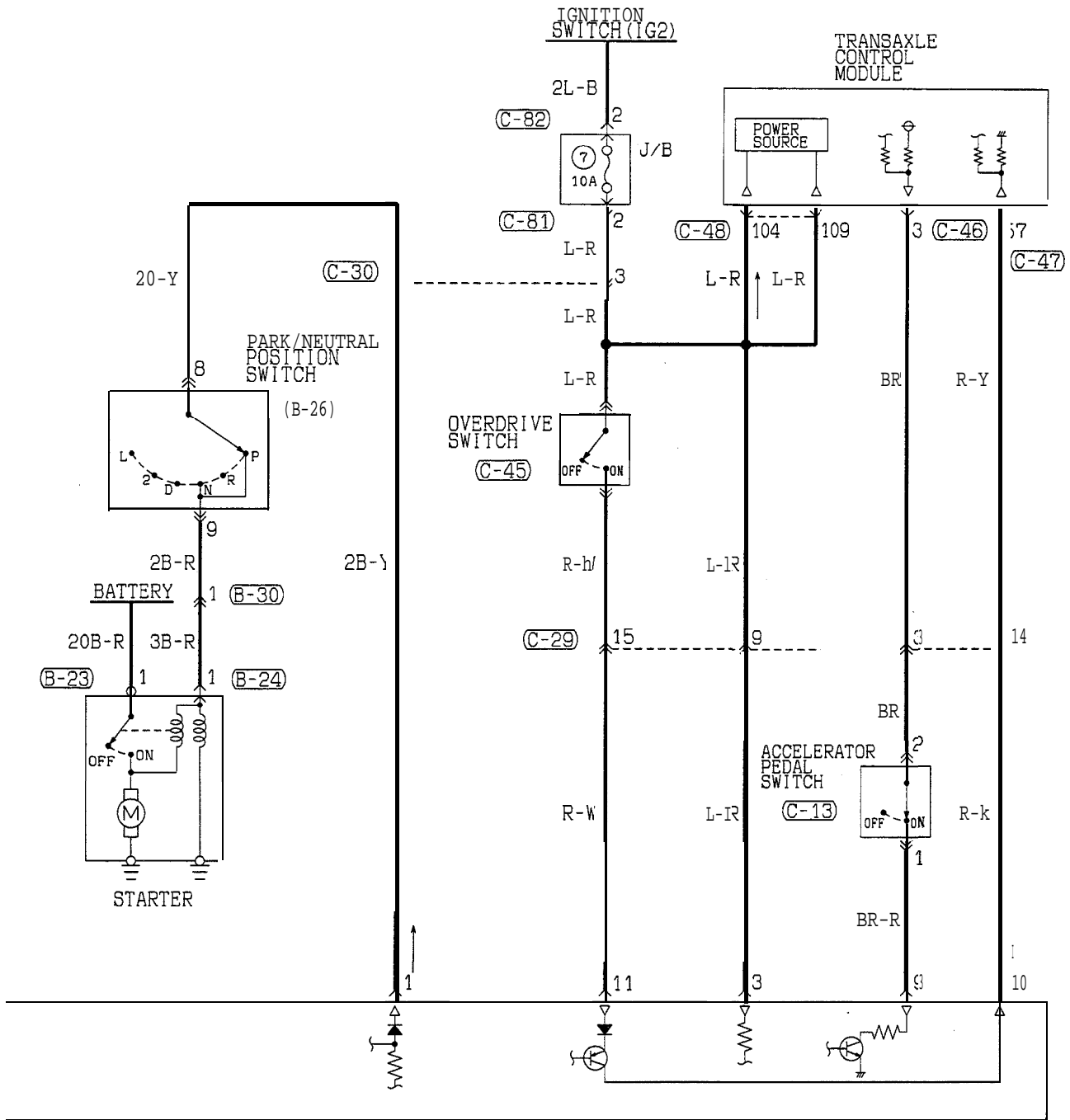

AUTO-CRUISE CONTROL UNIT (c-37)

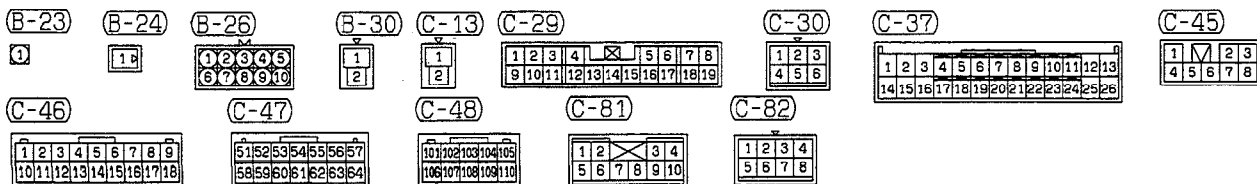

**AUTO-CRUISE CONTROL CIRCUIT (1993 MODELS)**

<A/T>

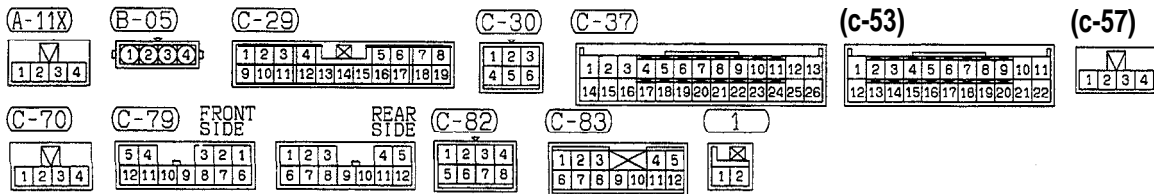
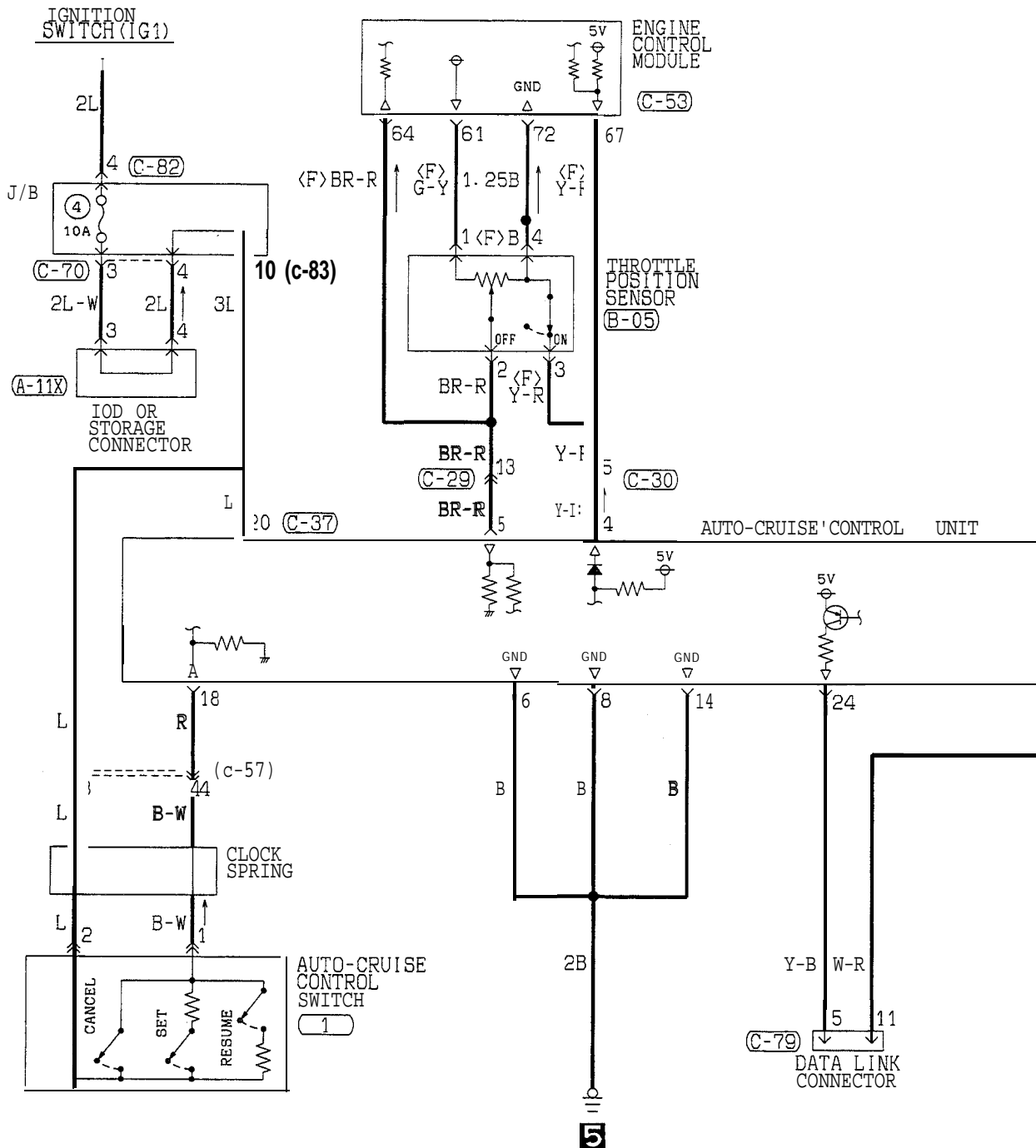

TSB Revision

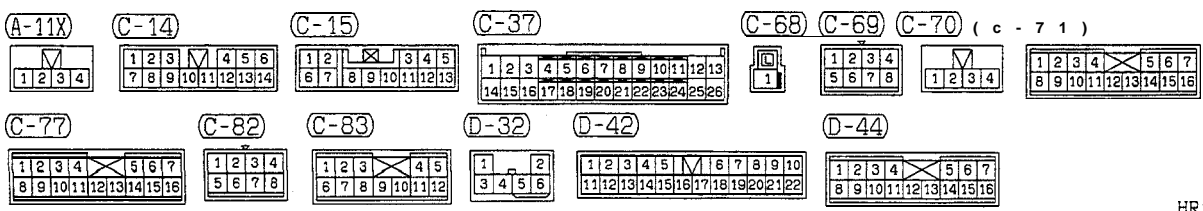
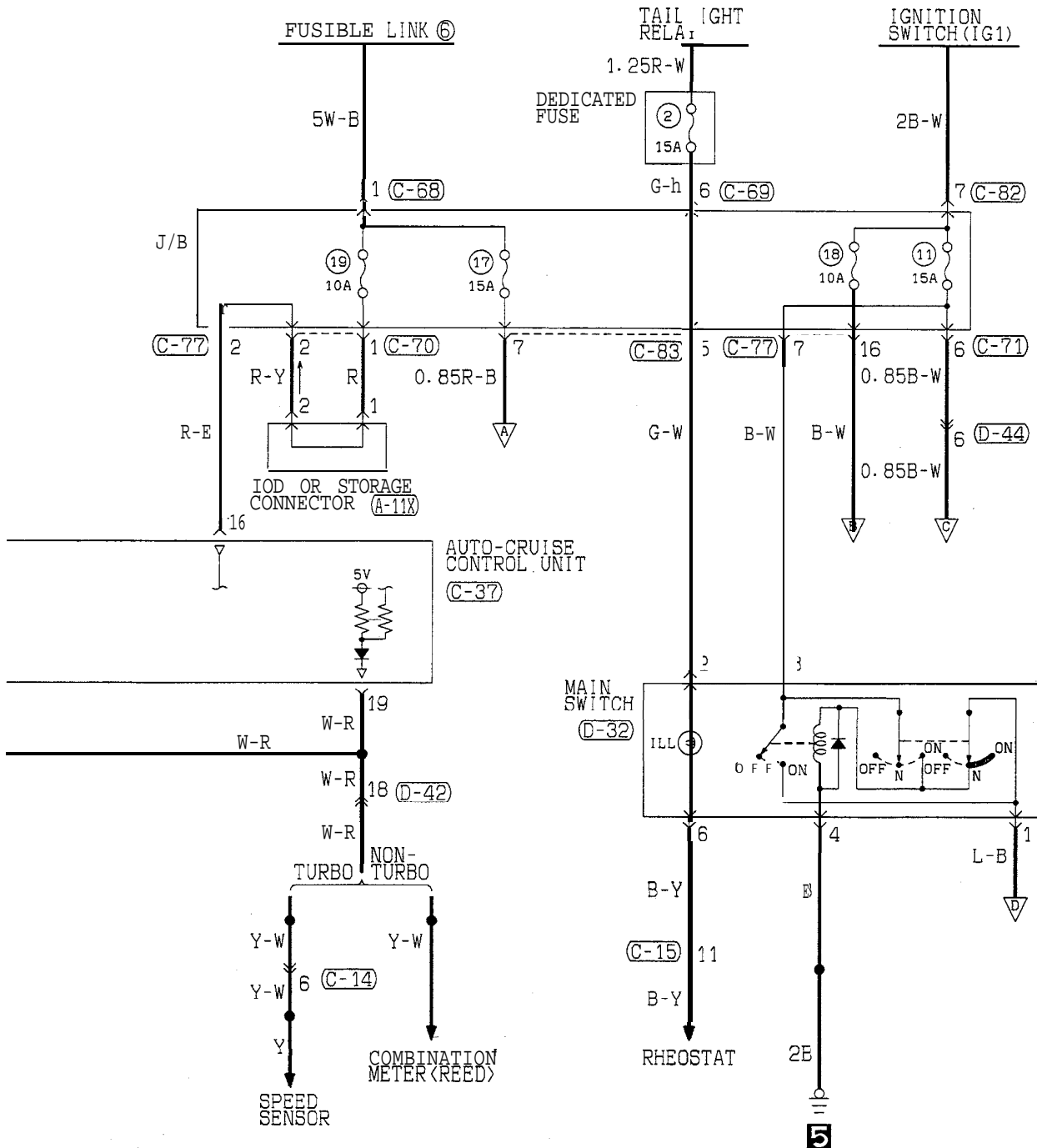

HR15M23AB

TSB Revision



AUTO-CRUISE CONTROL CIRCUIT (1993 MODELS) <A/T>  
(CONTINUED)

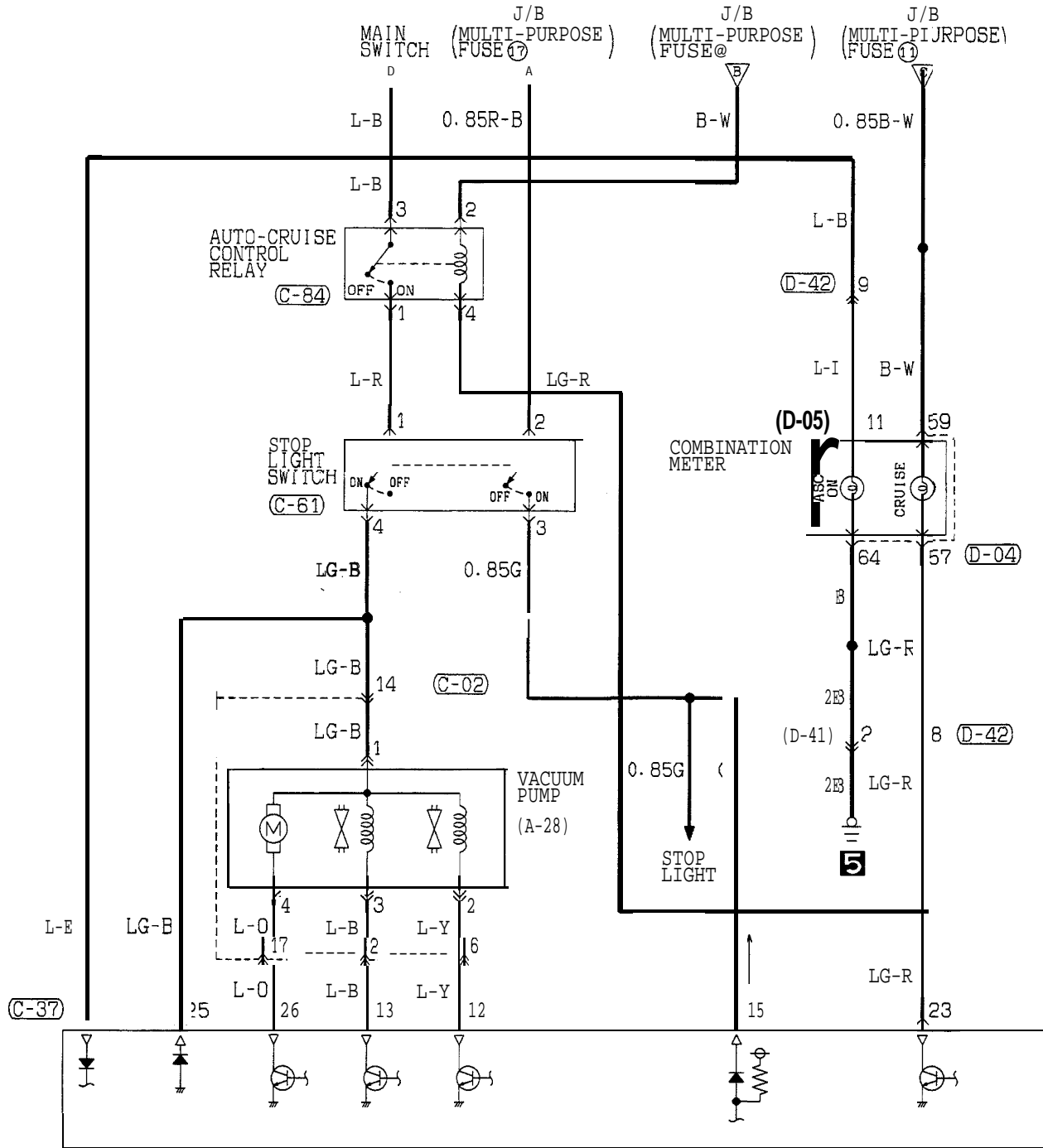

AUTO-CRUISE CONTROL UNIT

A-28



C-02

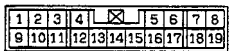

C-37

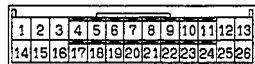

C-61



C-84



D-04

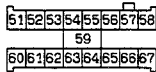

D-05

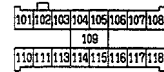

D-41



D-42

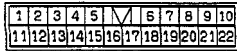

TSB Revision

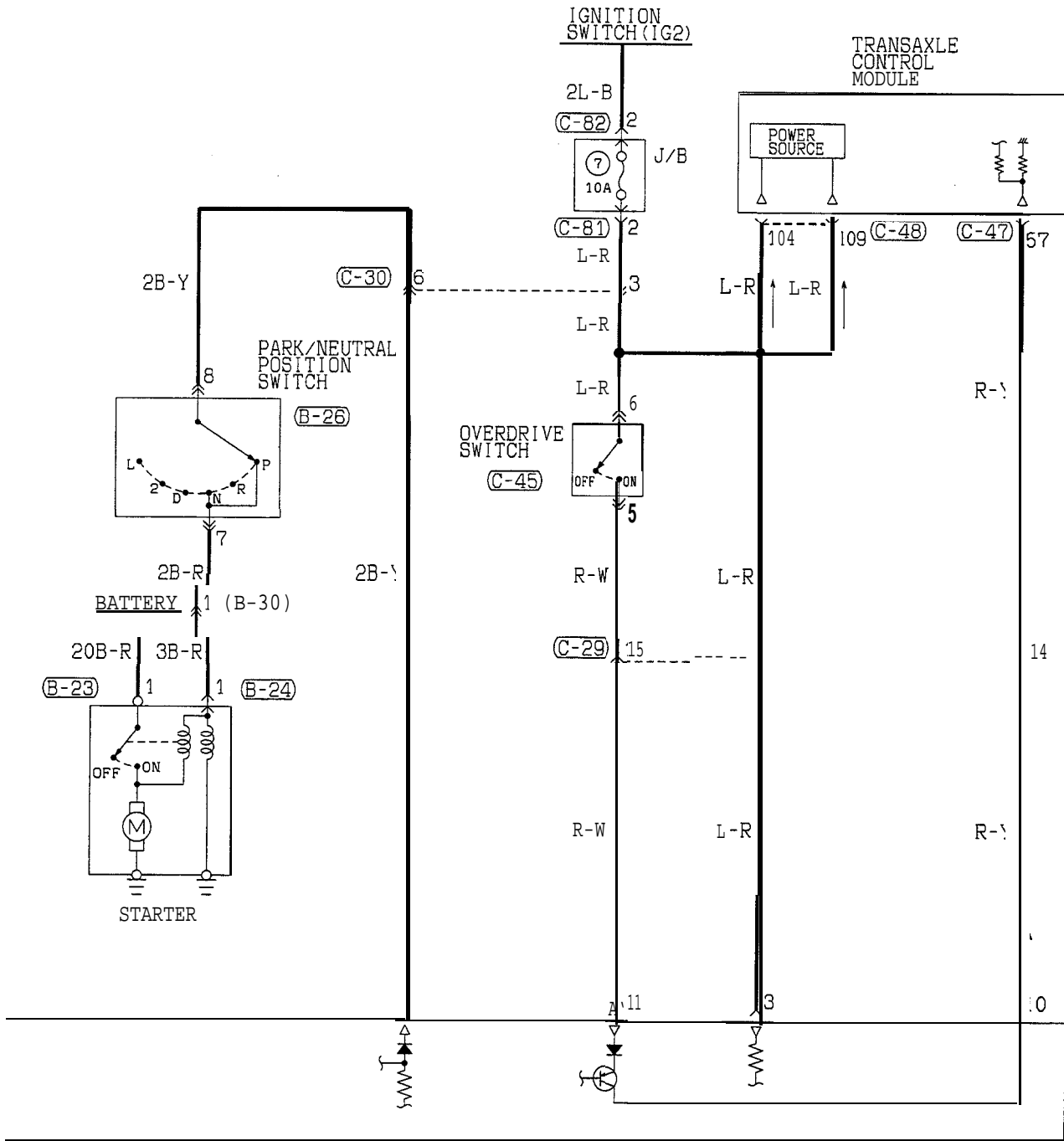

AUTO-CRUISE CONTROL UNIT (c-37)

B-23



B-24



B-26



B-30



C-29



C-30



C-37

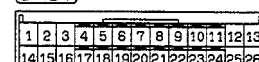

C-45



C-47

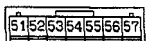

C-48

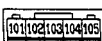

C-81

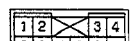

C-82



**AUTO-CRUISE CONTROL CIRCUIT (1994, 1995 MODELS)**

<A/T> (FEDERAL)

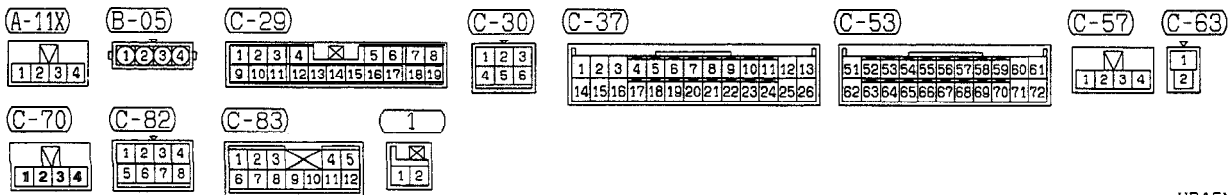
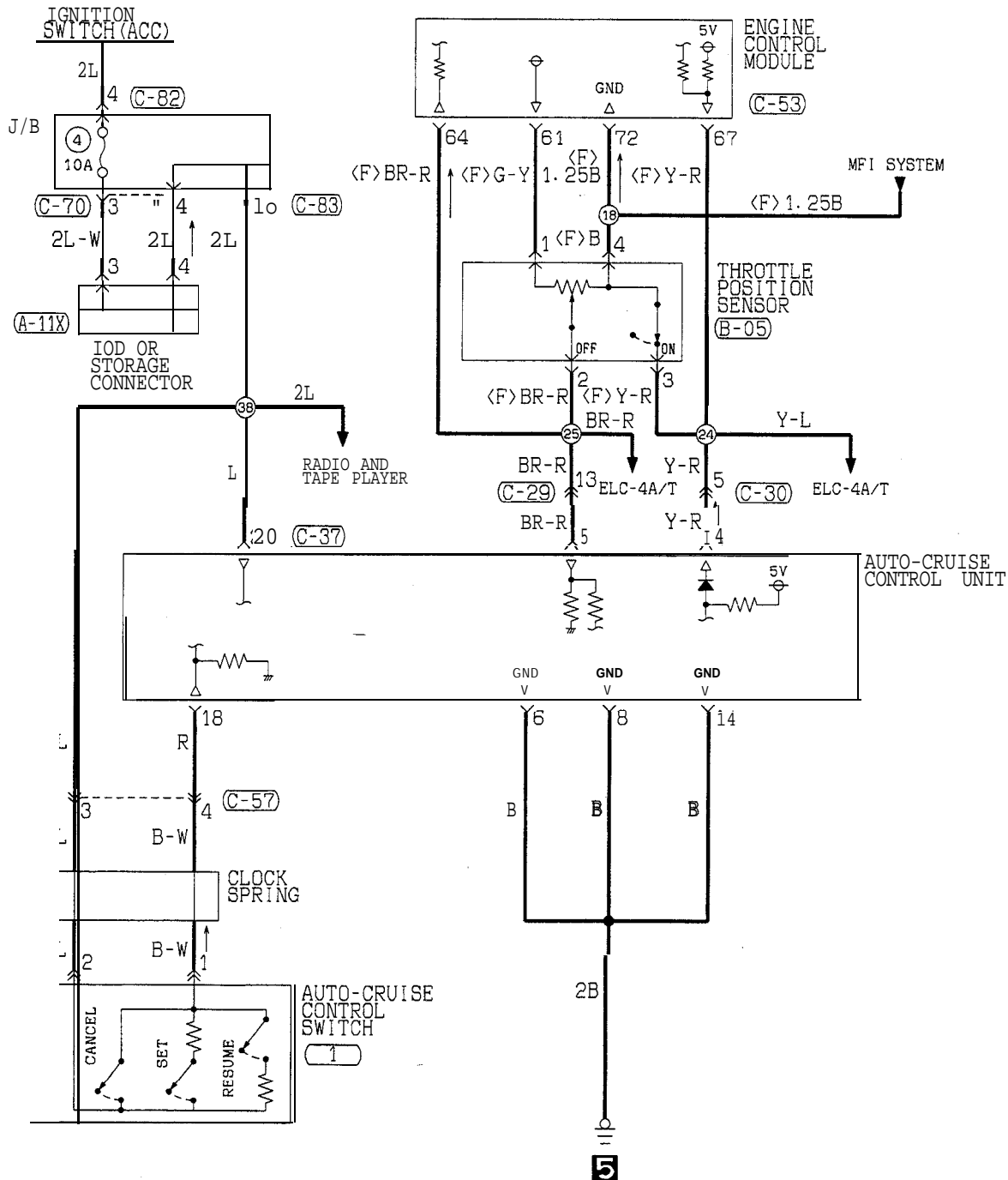

HR15M24AA

**TSB Revision**

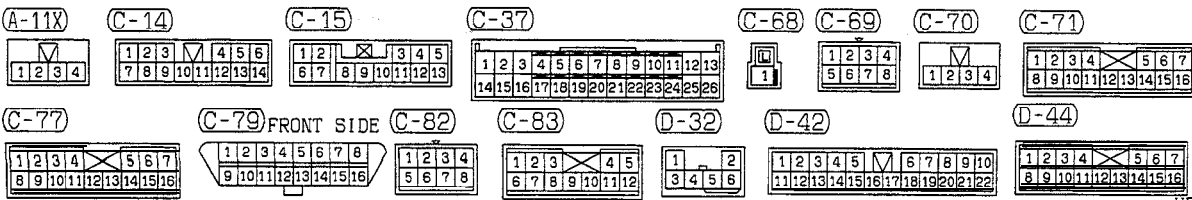
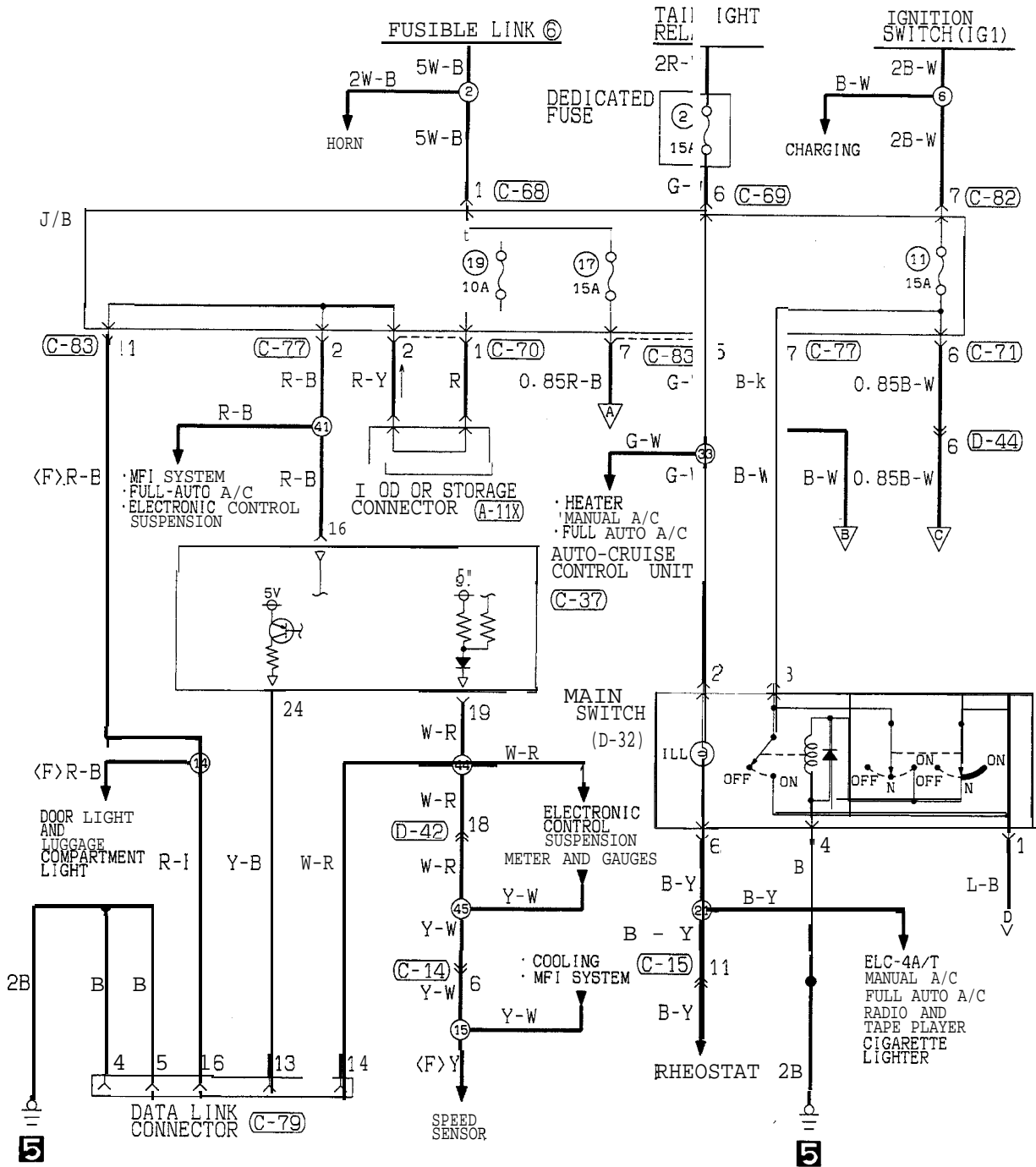

TSB Revision

**AUTO-CRUISE CONTROL CIRCUIT (1994, 1995 MODELS) <A/T> (FEDERAL)**  
**(CONTINUED)**

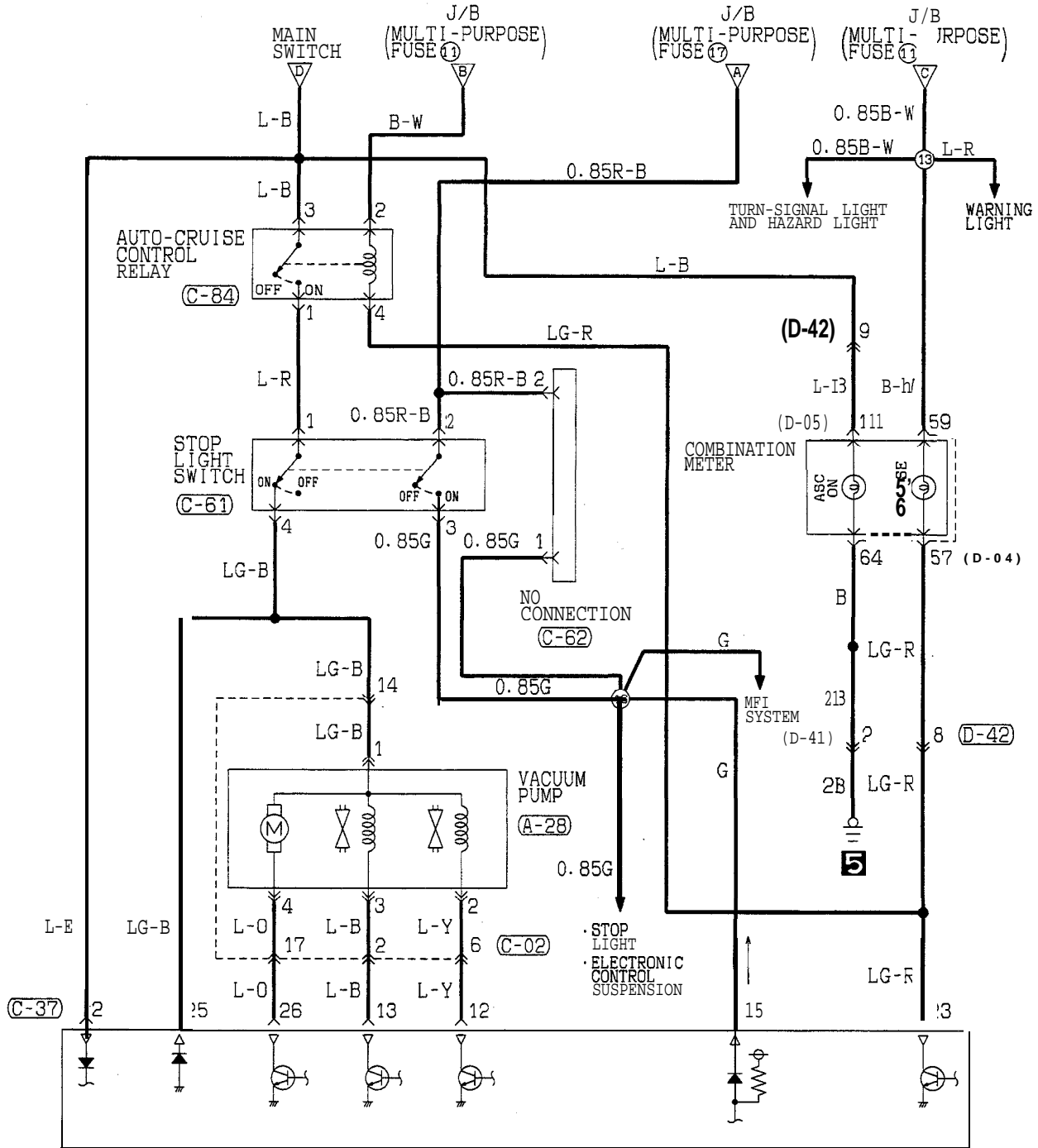

AUTO-CRUISE CONTROL UNIT

A-28



C-02

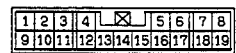

C-37

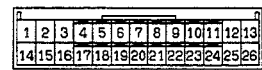

C-61



C-62



C-84



D-04

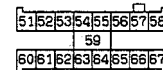

D-05

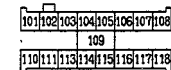

D-41



D-42

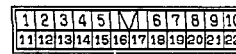

TSB Revision

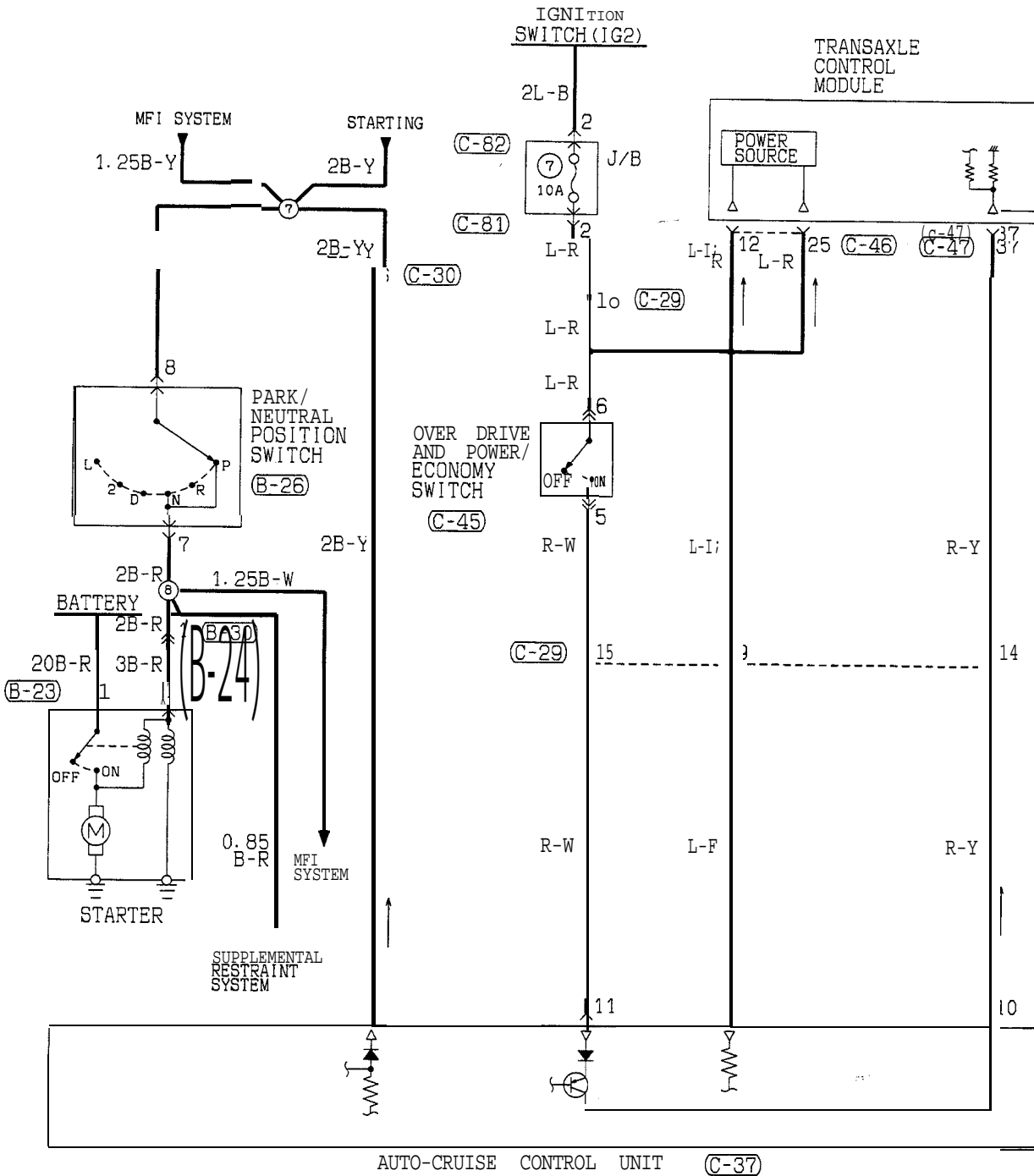

AUTO-CRUISE CONTROL UNIT (C-37)

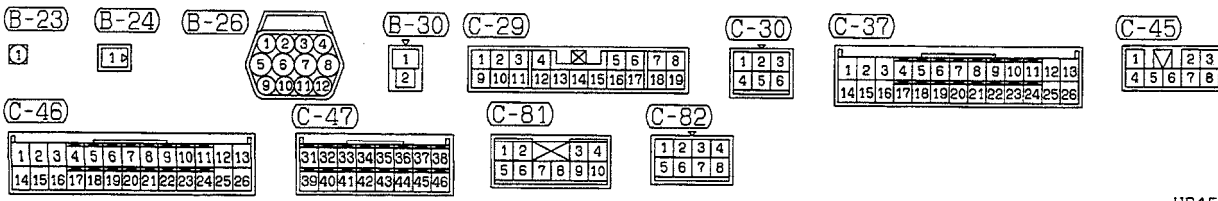

TSB Revision

**AUTO-CRUISE CONTROL CIRCUIT (1994, 1995 MODELS)**

<A/T> (CALIFORNIA)

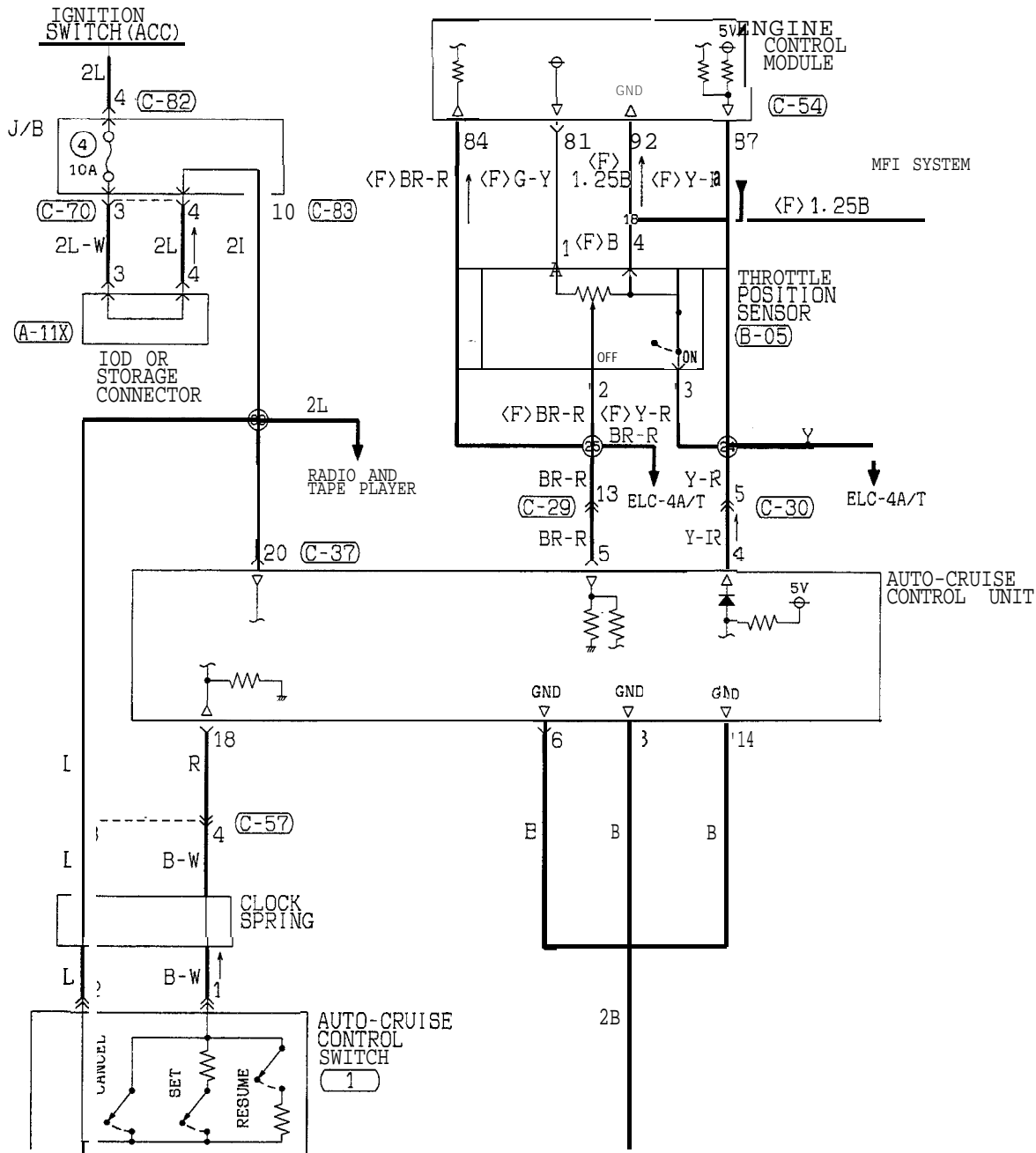

**5**

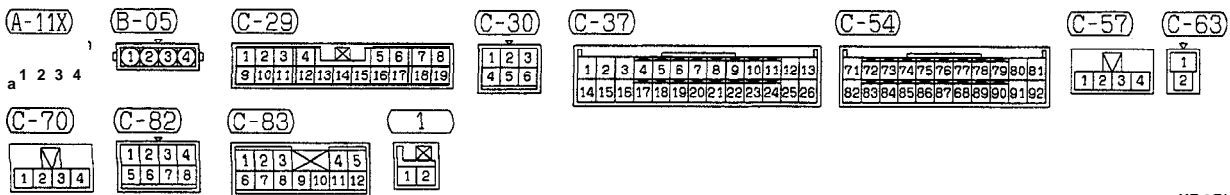

TSB Revision

NOTE  
 \*1: HATCHBACK  
 \*2: CONVERTIBLE

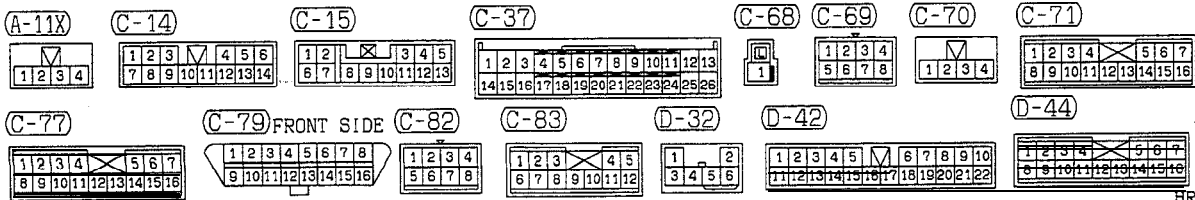
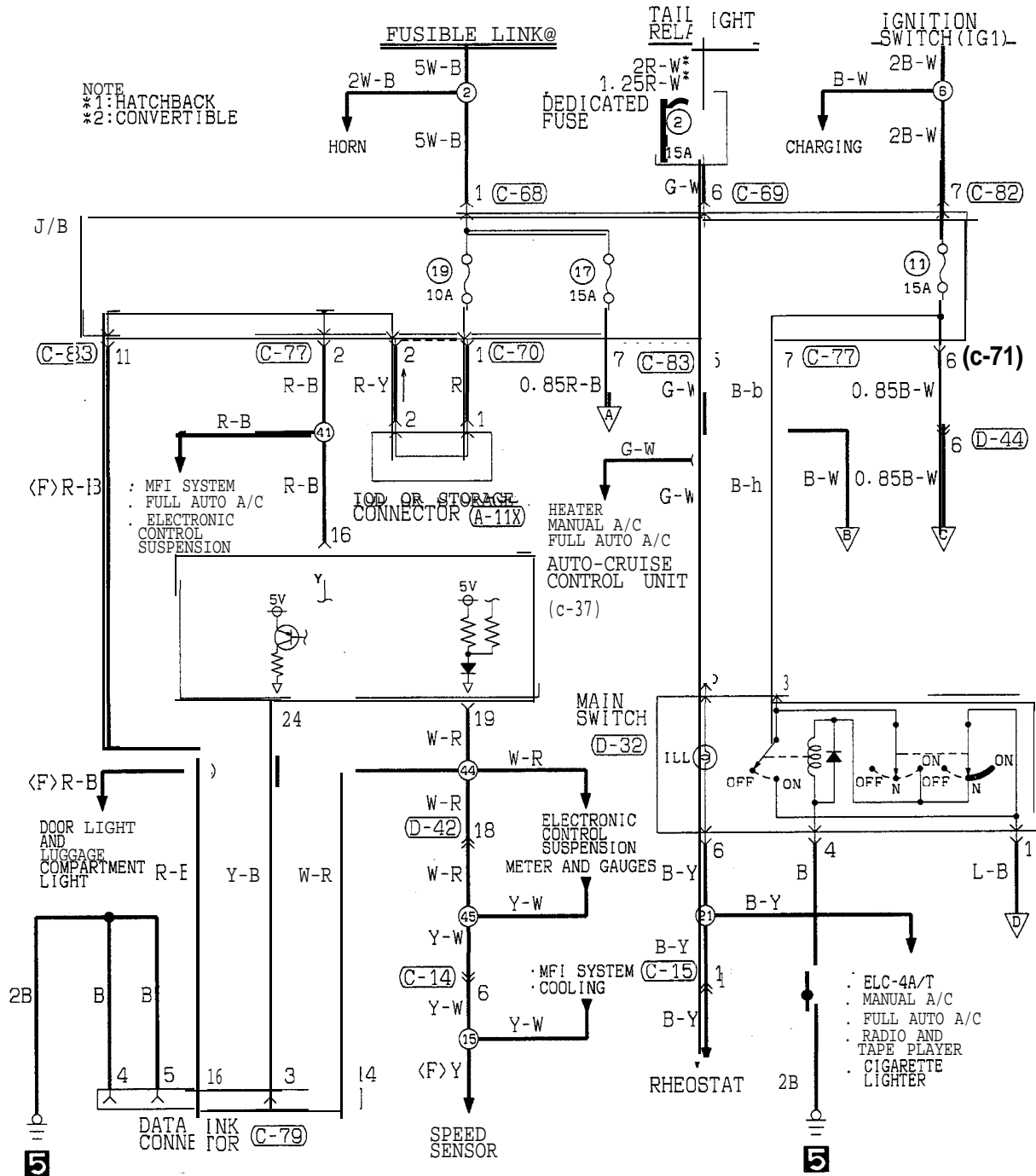

HR15M25AB



AUTO-CRUISE CONTROL CIRCUIT (1994, 1995 MODELS) <A/T> (CALIFORNIA)  
(CONTINUED)

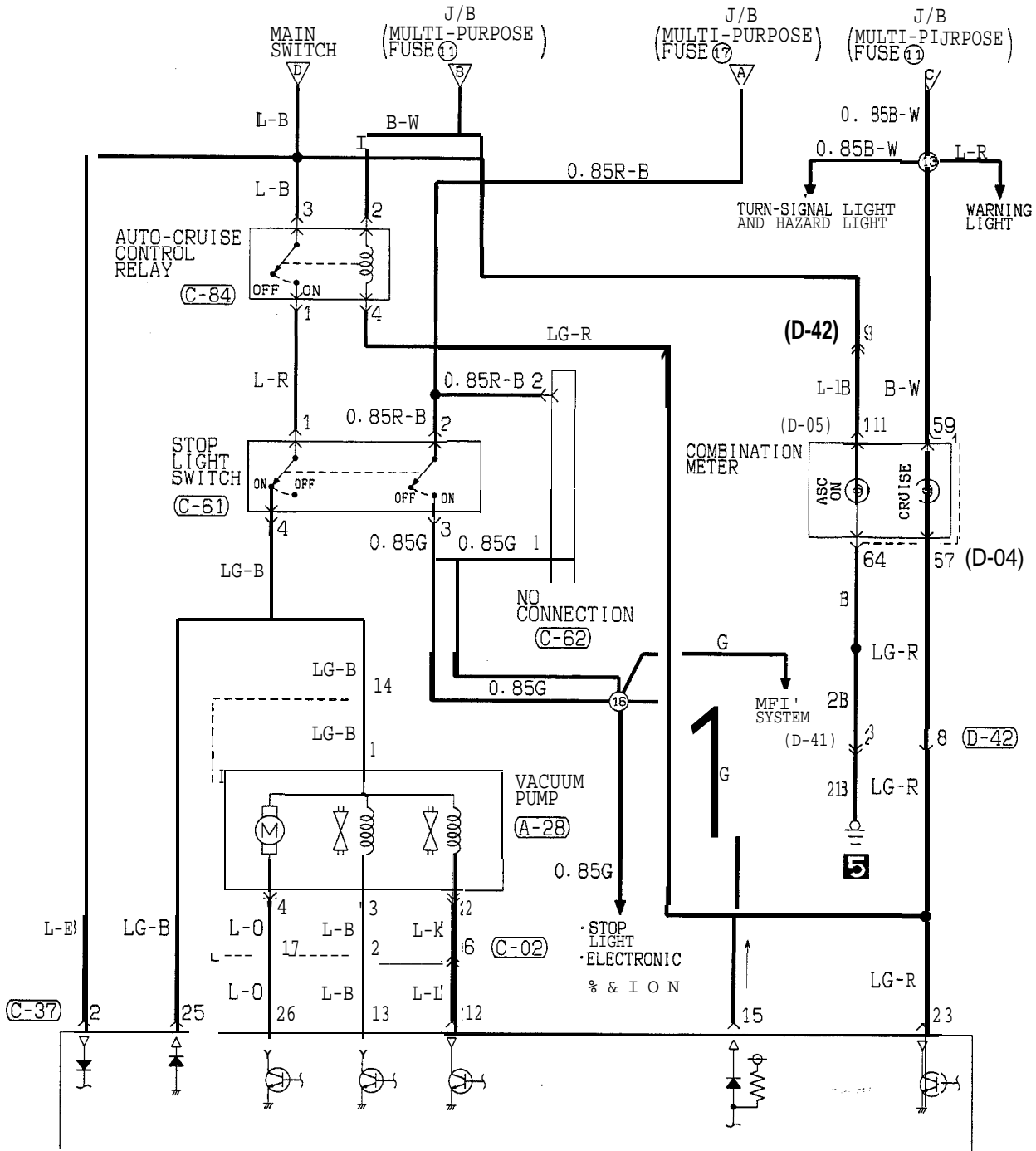

AUTO-CRUISE CONTROL UNIT

(A-28) (C-02)

1	2
3	4

1	2	3	4	5	6	7	8			
9	10	11	12	13	14	15	16	17	18	19

(C-37)

1	2	3	4	5	6	7	8	9	10	11	12	13
14	15	16	17	18	19	20	21	22	23	24	25	26

(C-61) (C-62) (C-84) (D-04)

1	2
3	4

1
2

1	2
3	4

51	52	53	54	55	56	57	58
59							
60	61	62	63	64	65	66	67

(D-05)

101	102	103	104	105	106	107	108
				109			
110	111	113	114	115	116	117	118

(D-41) (D-42)

1	2
3	4

1	2	3	4	5	6	7	8	9	10		
11	12	13	14	15	16	17	18	19	20	21	22

TSB Revision

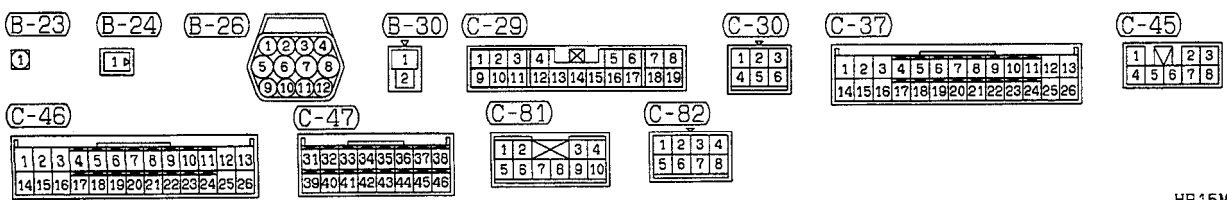
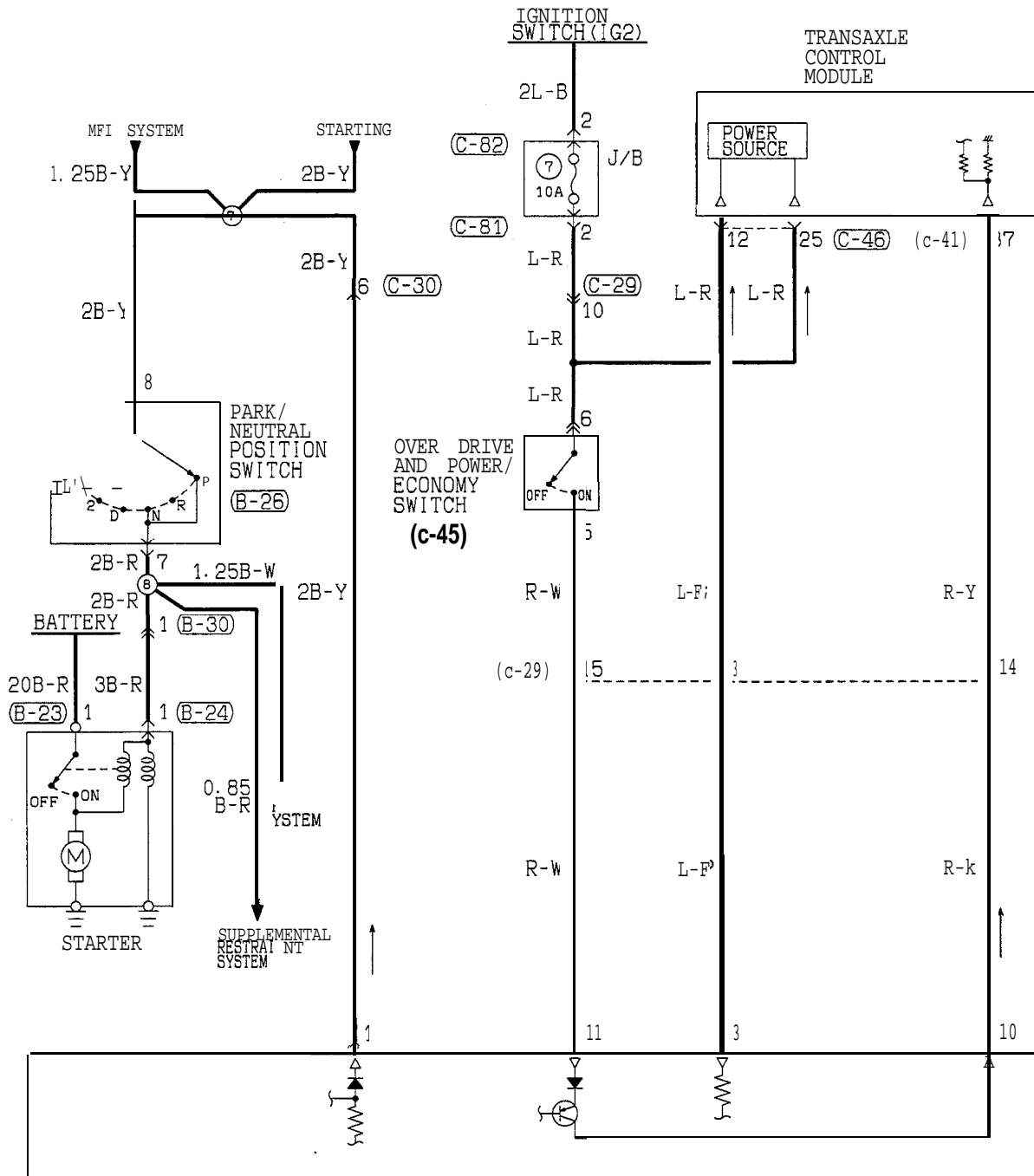

**AUTO-CRUISE CONTROL CIRCUIT (FROM 1996 MODELS)**

<A/T>

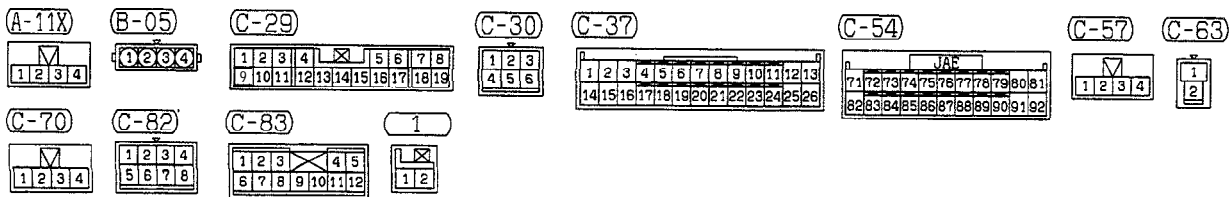
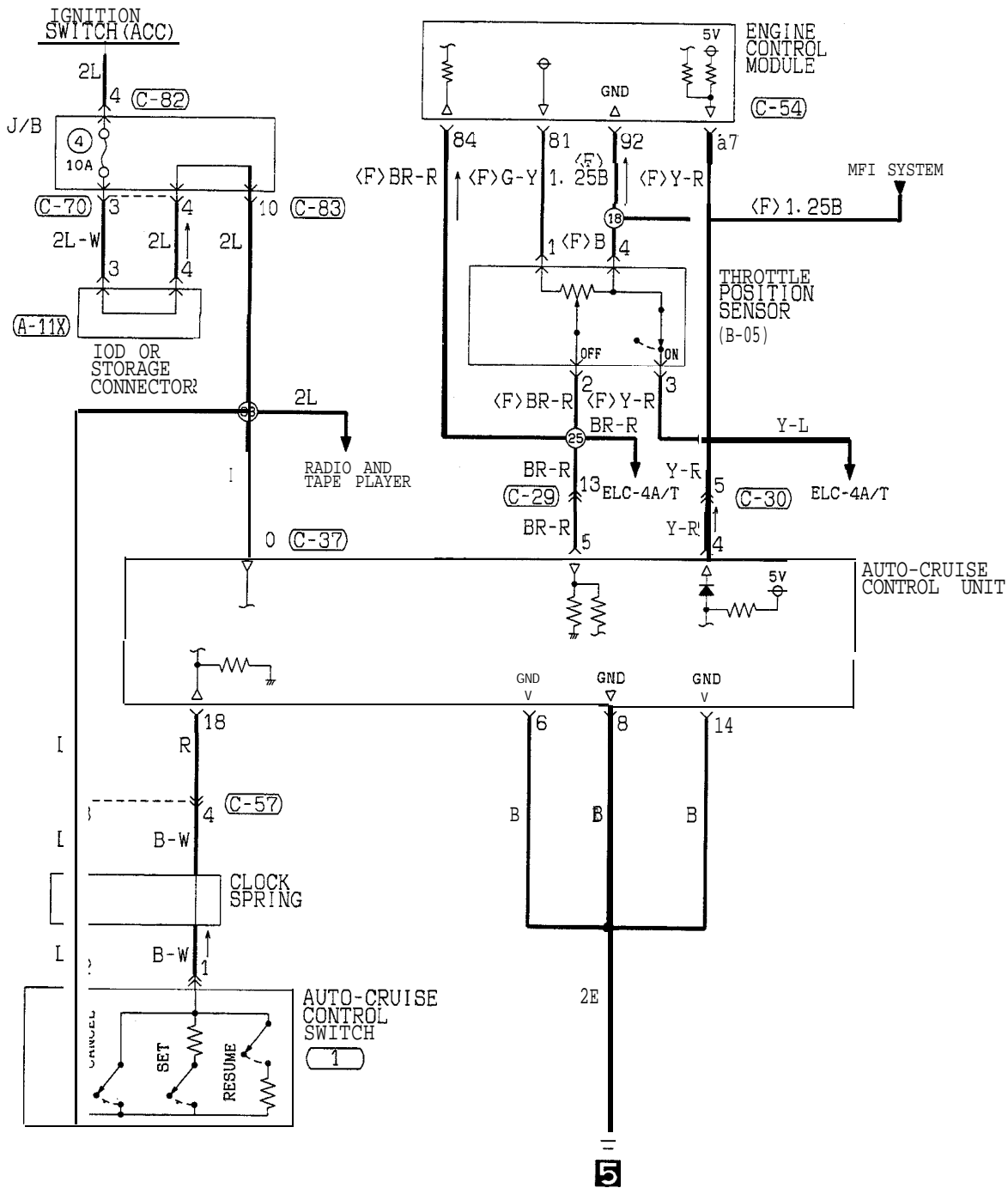

NOTE  
\*1: HATCHBACK  
\*2: CONVERTIBLE

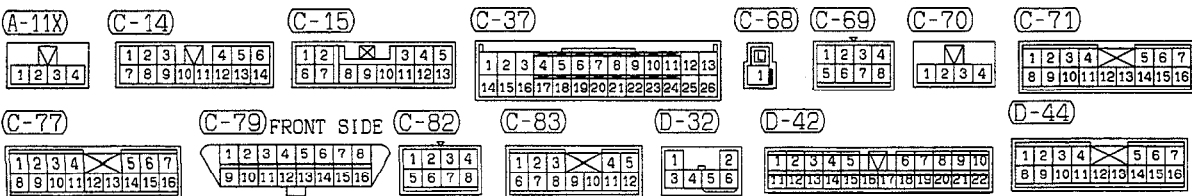
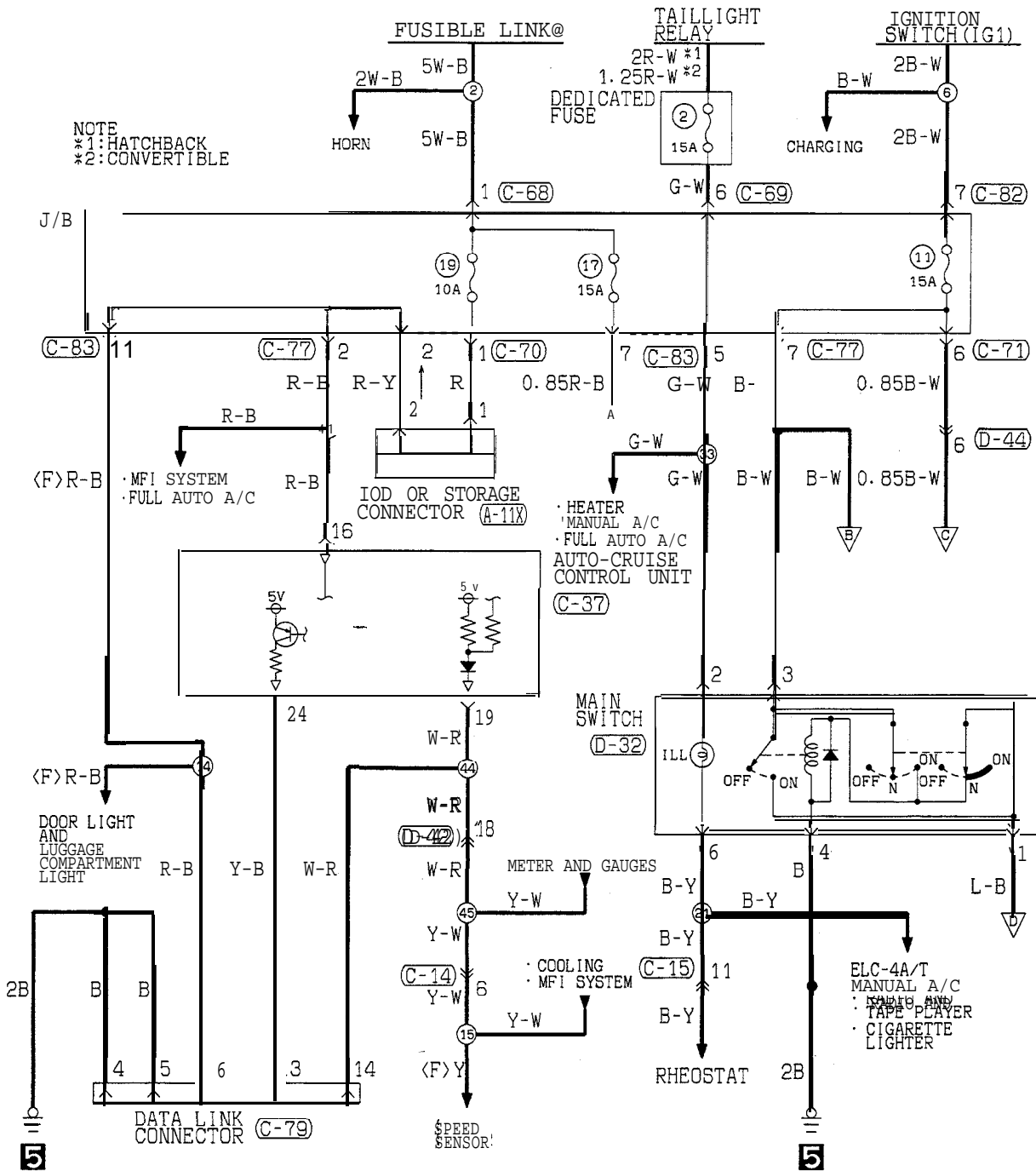

HR15M37AB

TSB Revision

AUTO-CRUISE CONTROL CIRCUIT (FROM 1996 MODELS)  
<A/T> (CONTINUED)

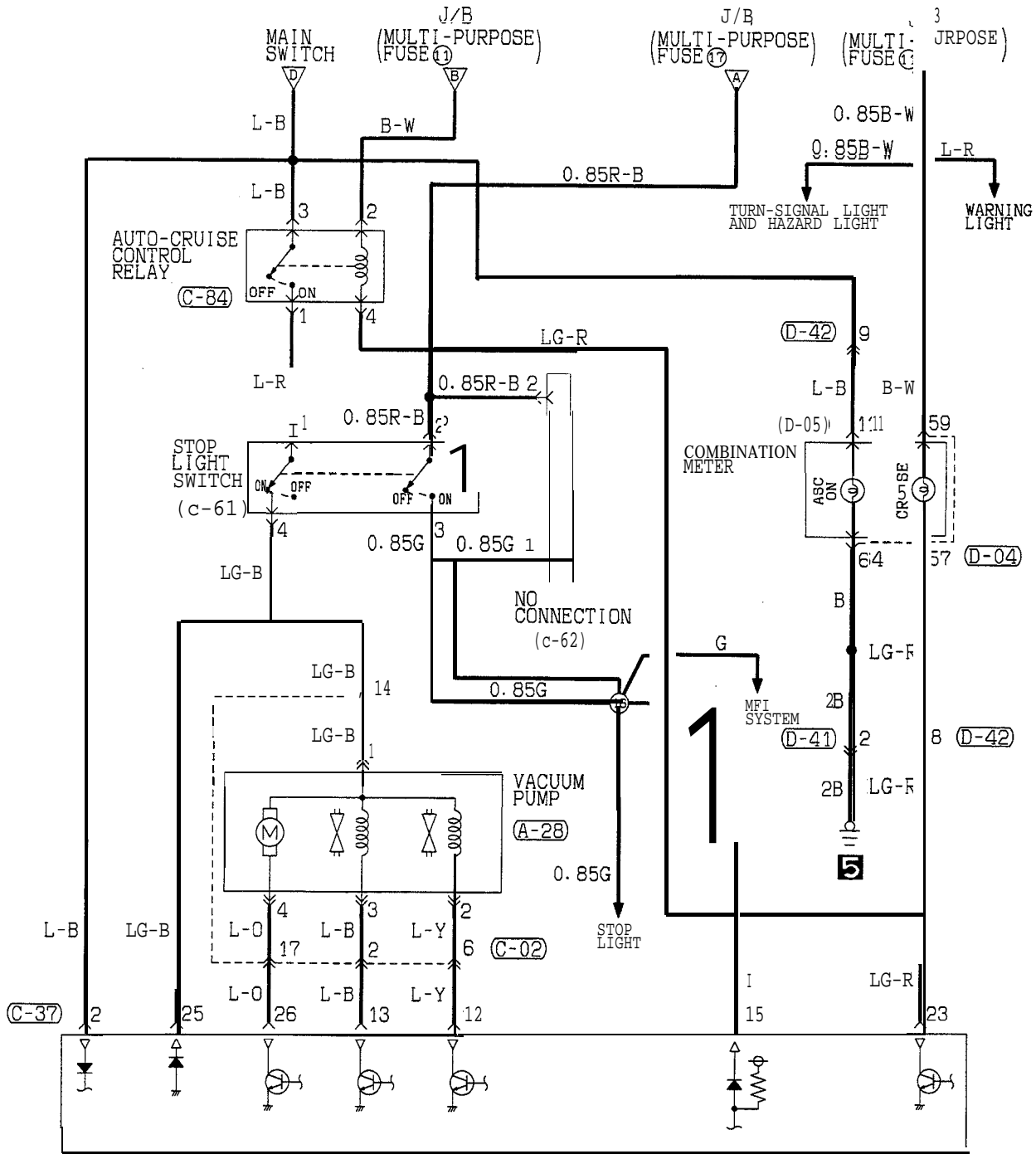

AUTO-CRUISE CONTROL UNIT

A-28

1	2
3	4

C-02

1	2	3	4	5	6	7	8			
9	10	11	12	13	14	15	16	17	18	19

C-37

1	2	3	4	5	6	7	8	9	10	11	12	13
14	15	16	17	18	19	20	21	22	23	24	25	26

C-61

1	2
3	4

C-62

1
2

C-84

1	2
3	4

D-04

5	1	2	3	4	5	6	7	5
6	0	6	1	6	5	6	6	7
5	9							

D-05

1	0	1	2	1	3	1	0	4	1	0	5	1	0	6	1	0	7	1	0	8	
1	0	9																			
1	0	9																			

D-41

1	2
3	4

D-42

1	2	3	4	5	6	7	8	9	10		
11	12	13	14	15	16	17	18	19	20	21	22

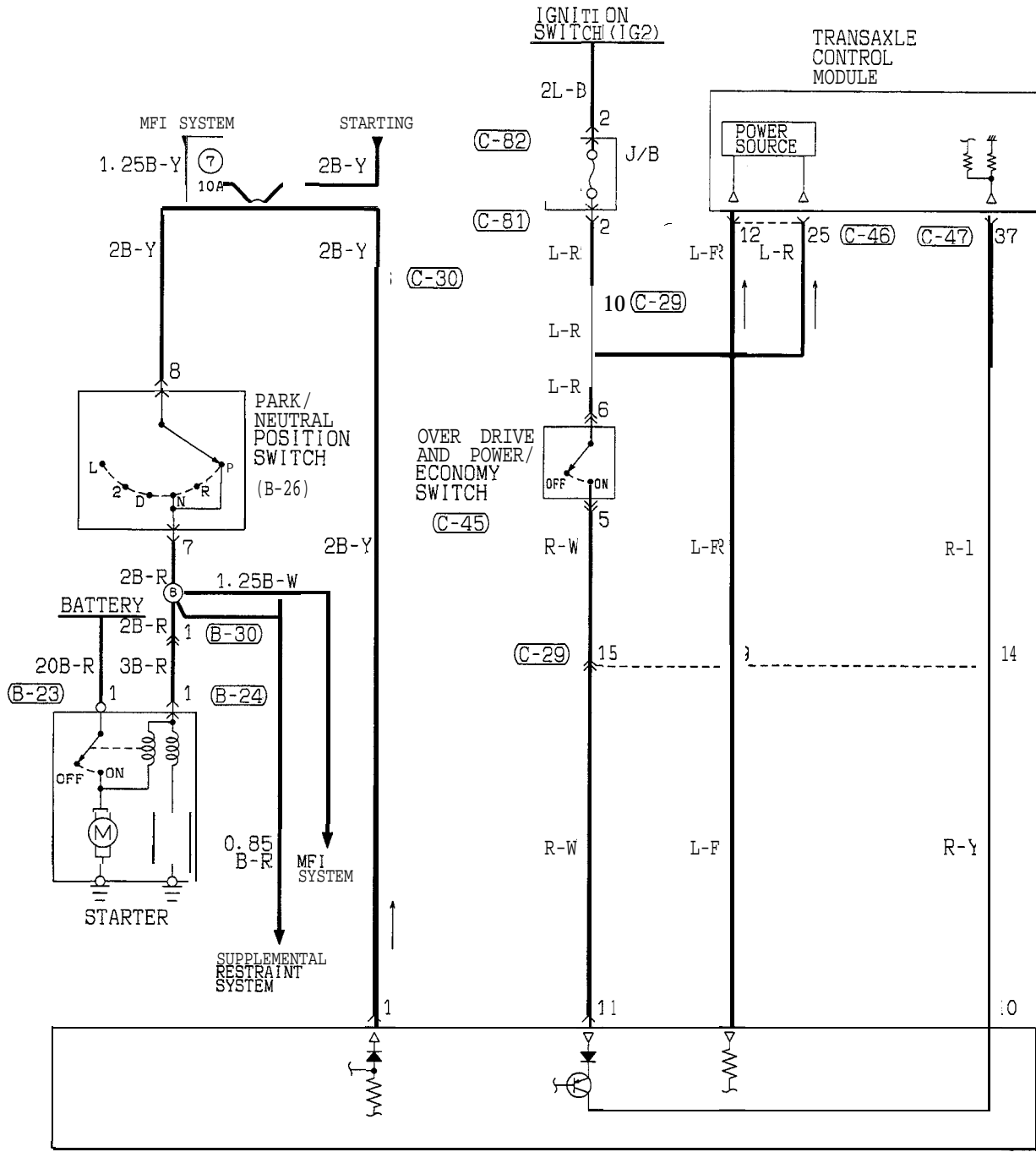

AUTO-CRUISE CONTROL UNIT (c-37)

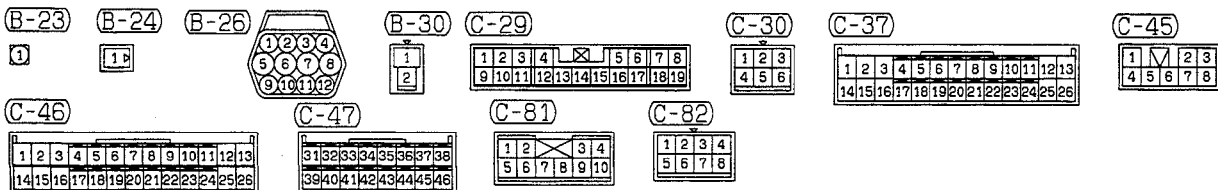

POWER SEAT CIRCUIT (UP TO 1993 MODELS)

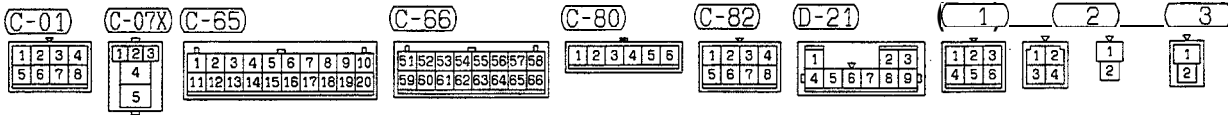
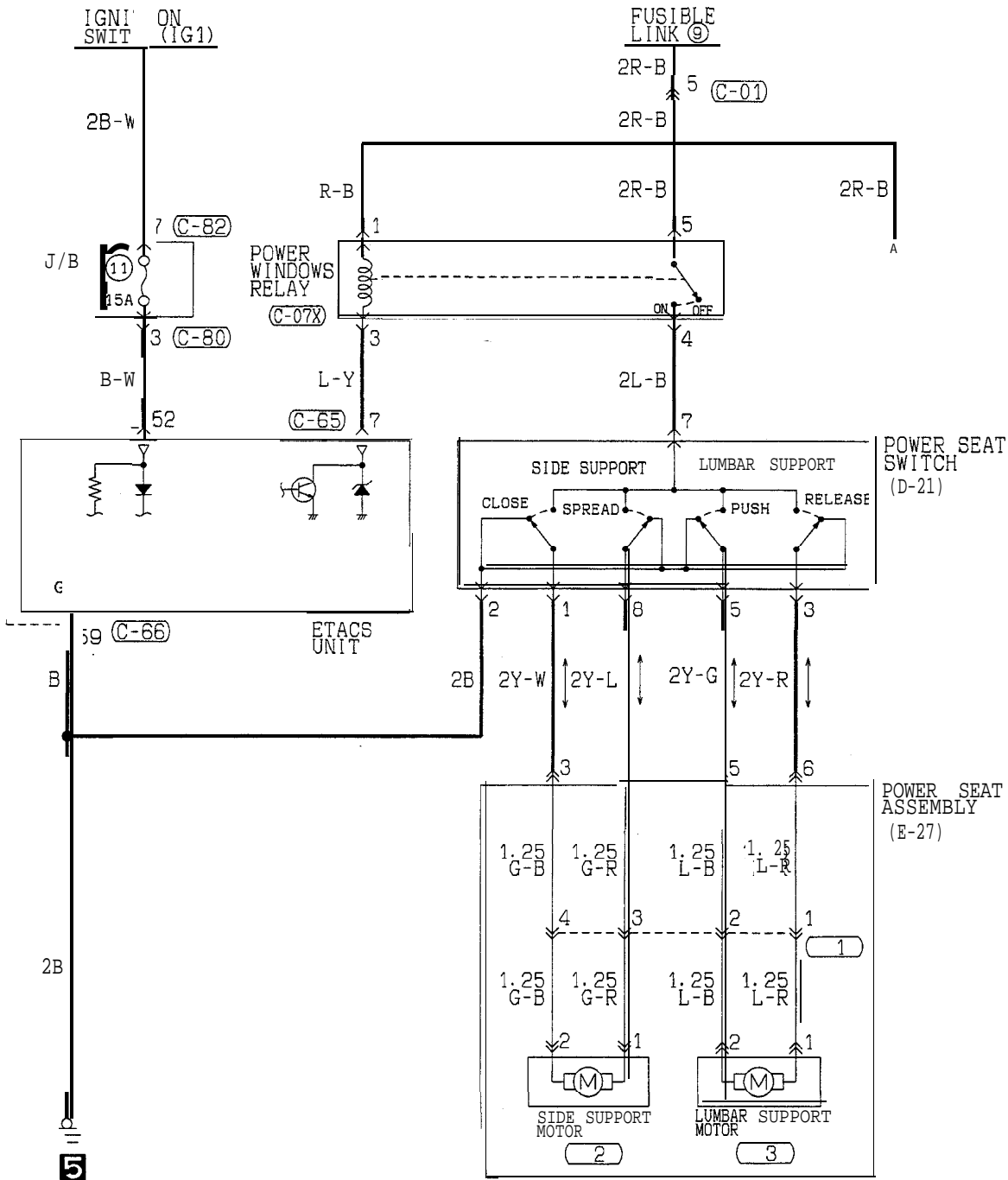

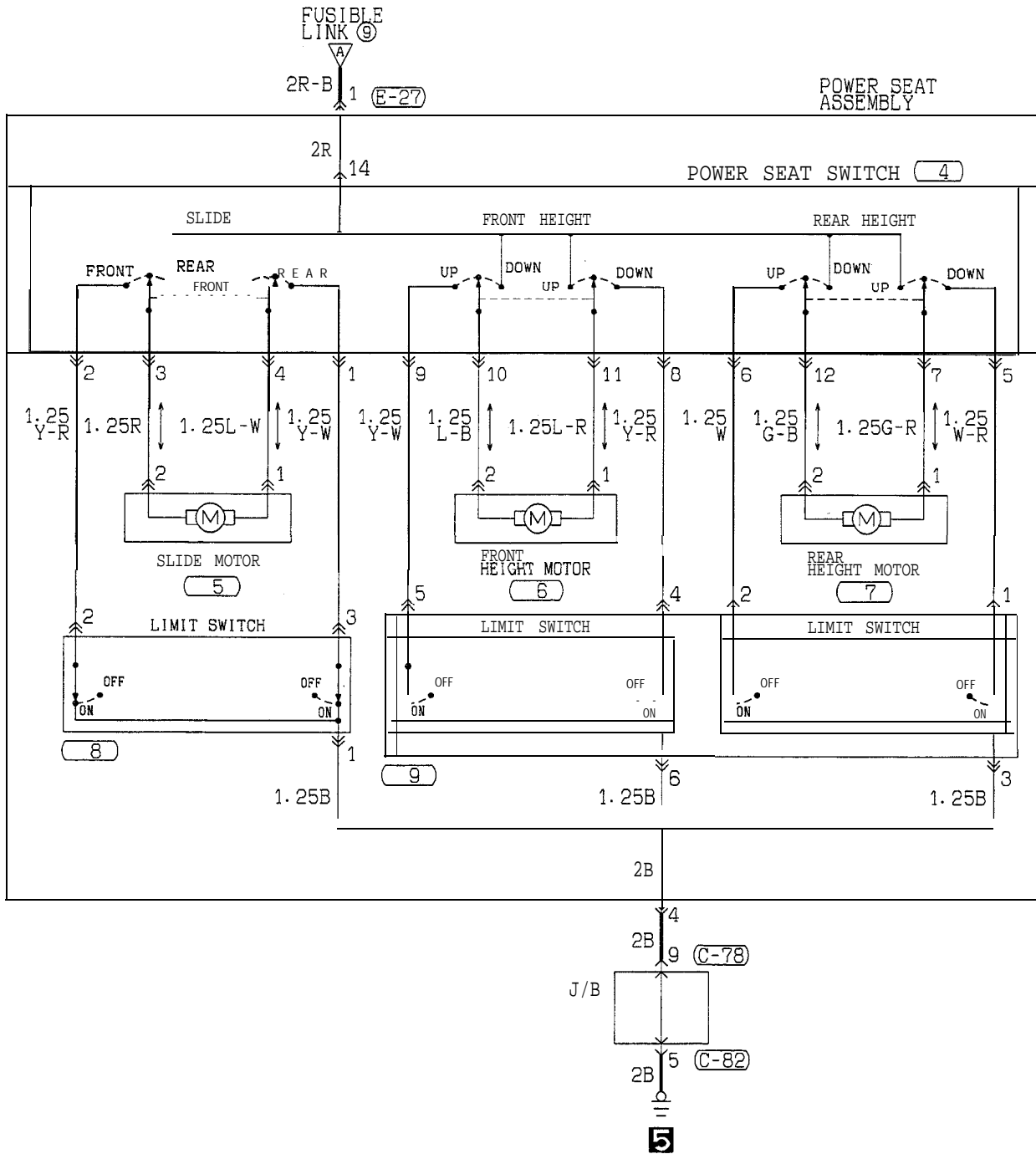

(C-78)

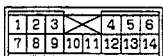

(C-82)



(E-27)



(4)

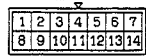

(5)



(6)



(7)



(8)



(9)





POWER SEAT CIRCUIT (1994, 1995 MODELS)

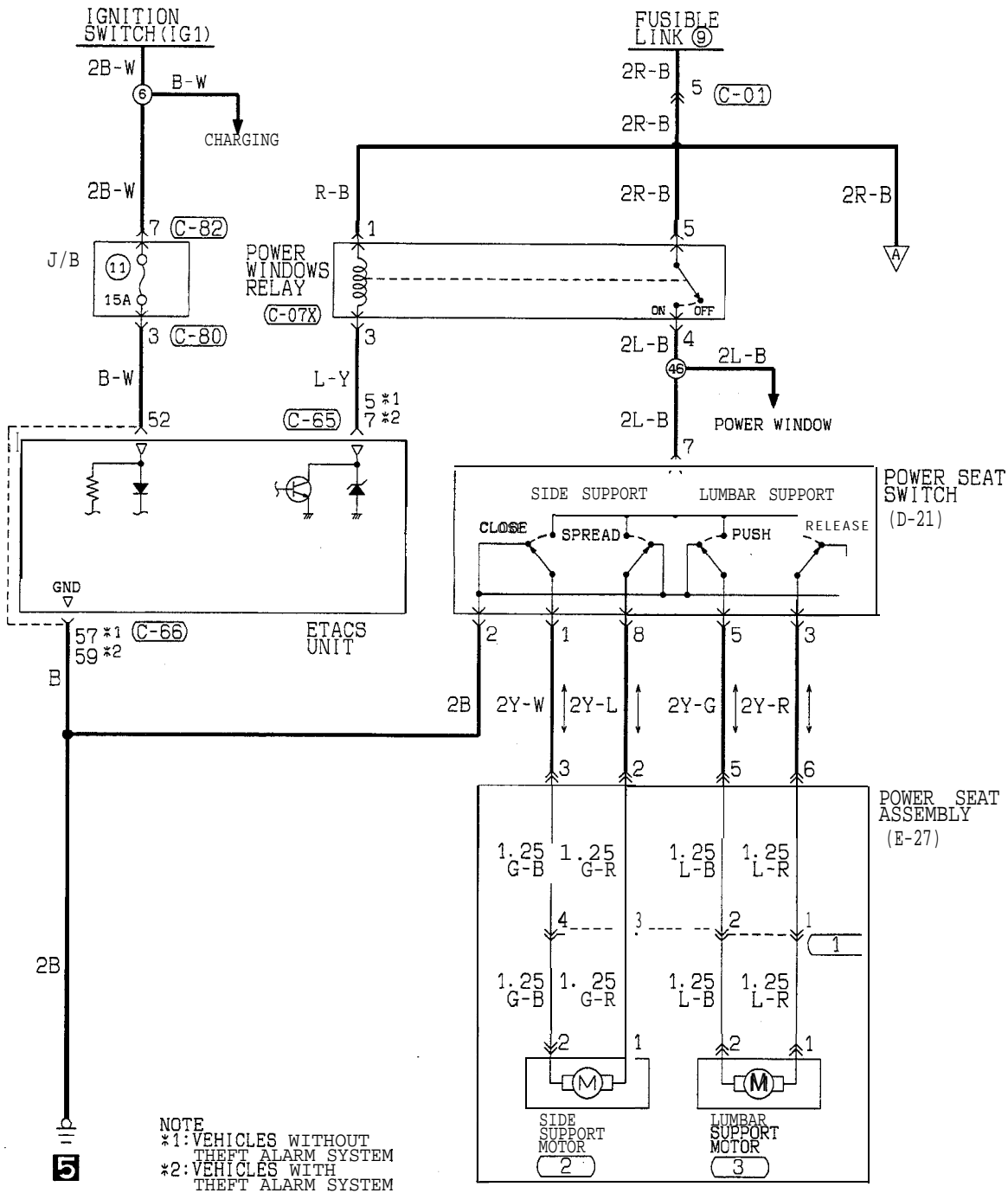

NOTE  
\*1: VEHICLES WITHOUT THEFT ALARM SYSTEM  
\*2: VEHICLES WITH THEFT ALARM SYSTEM

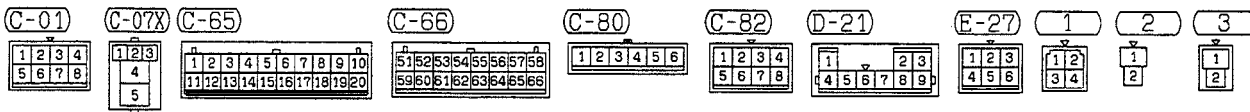

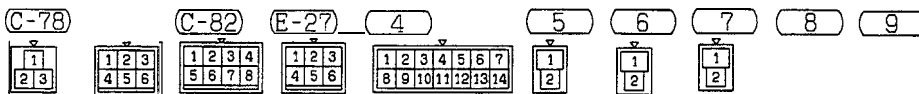
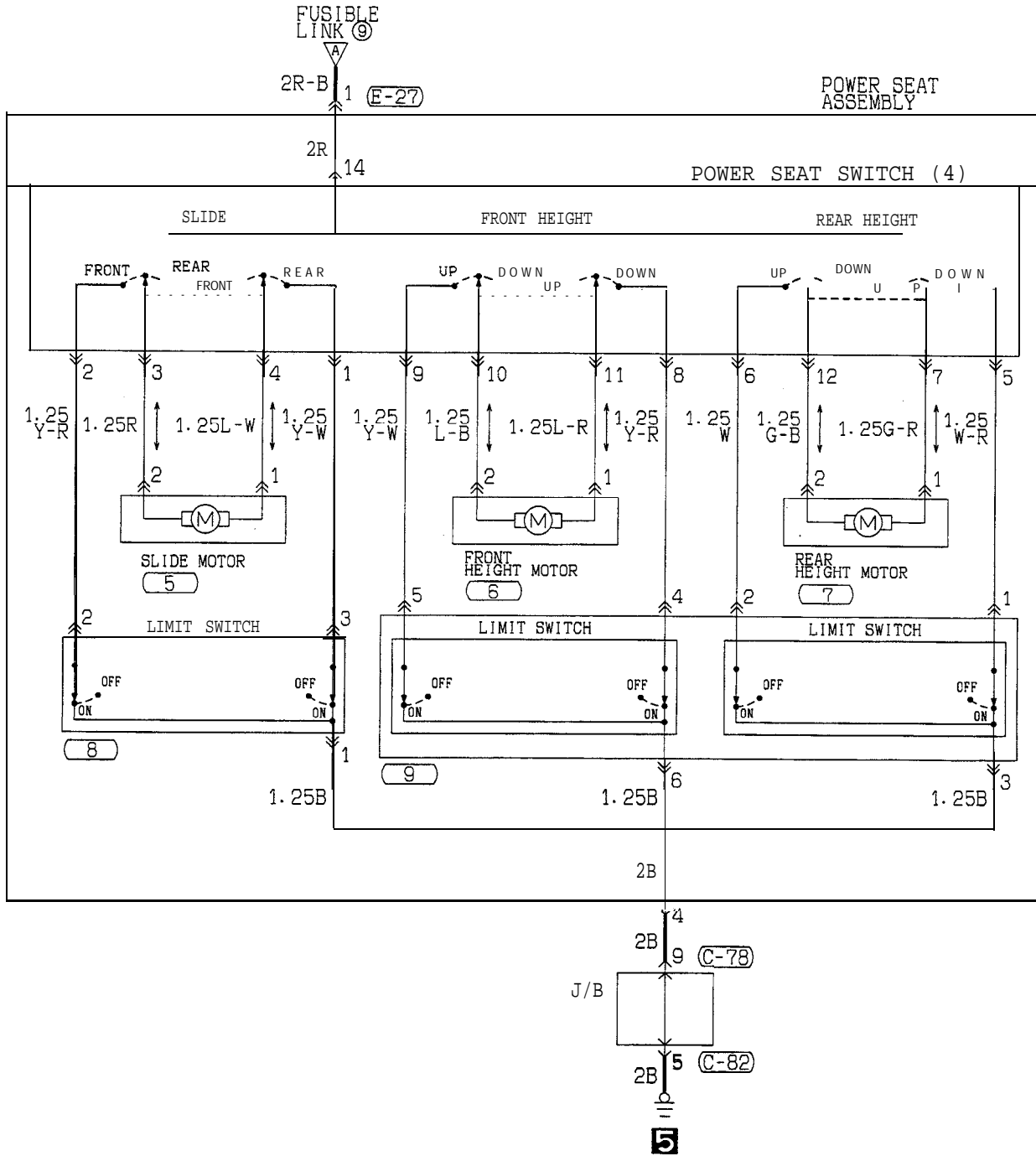

POWER SEAT CIRCUIT (FROM 1996 MODELS)

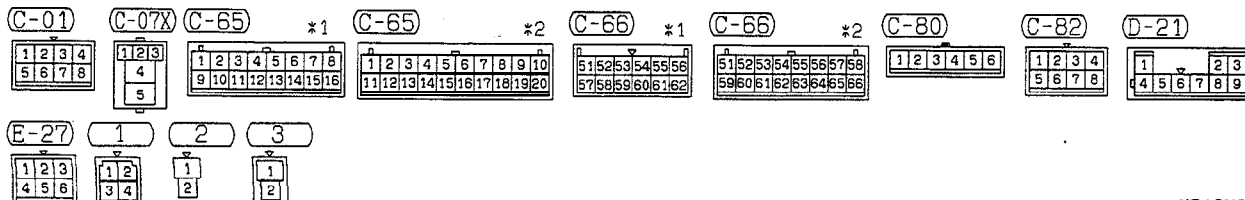
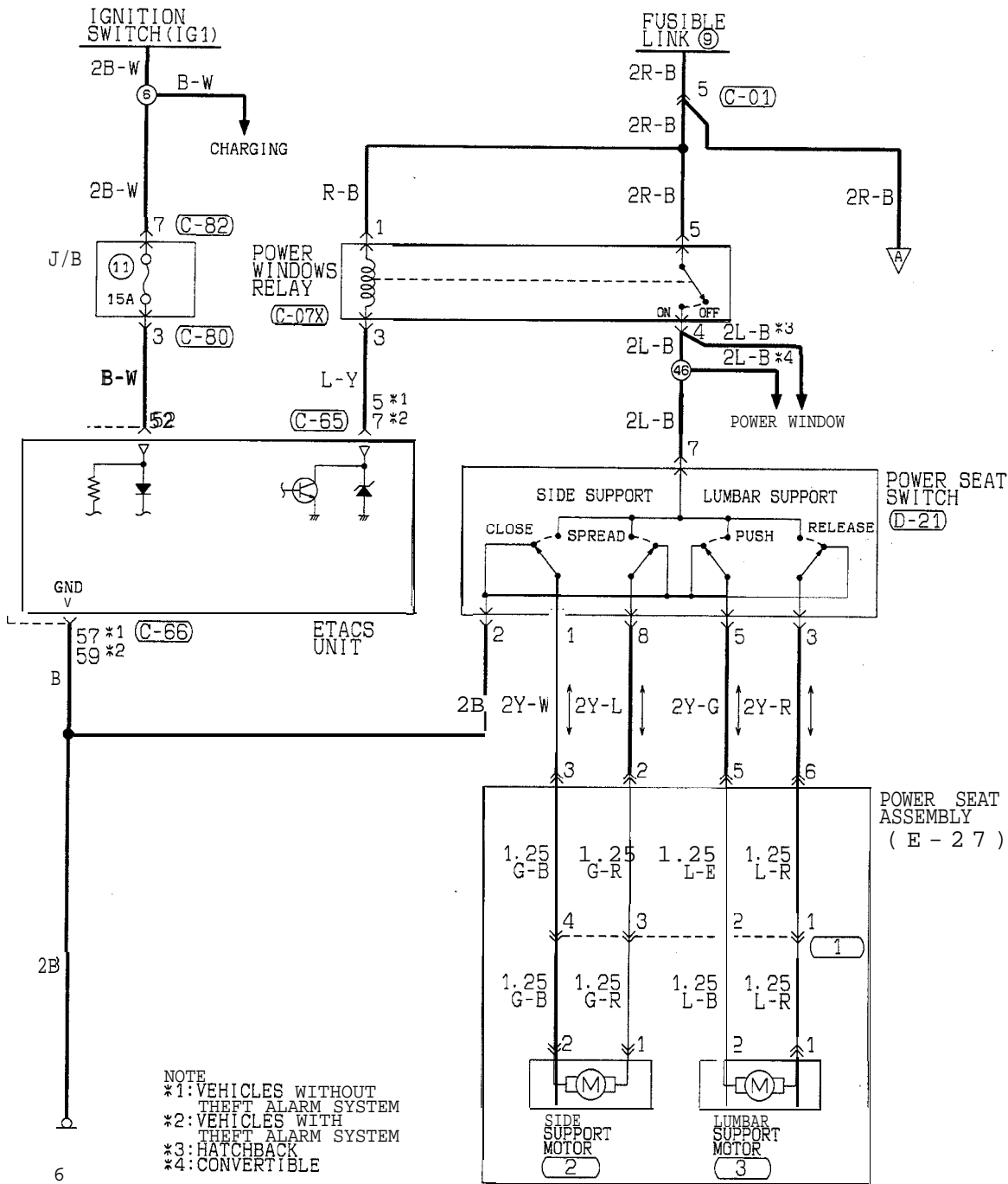

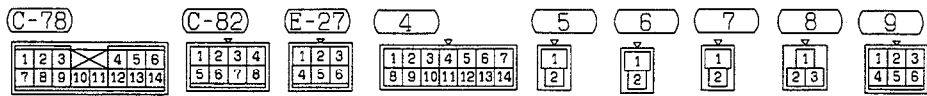
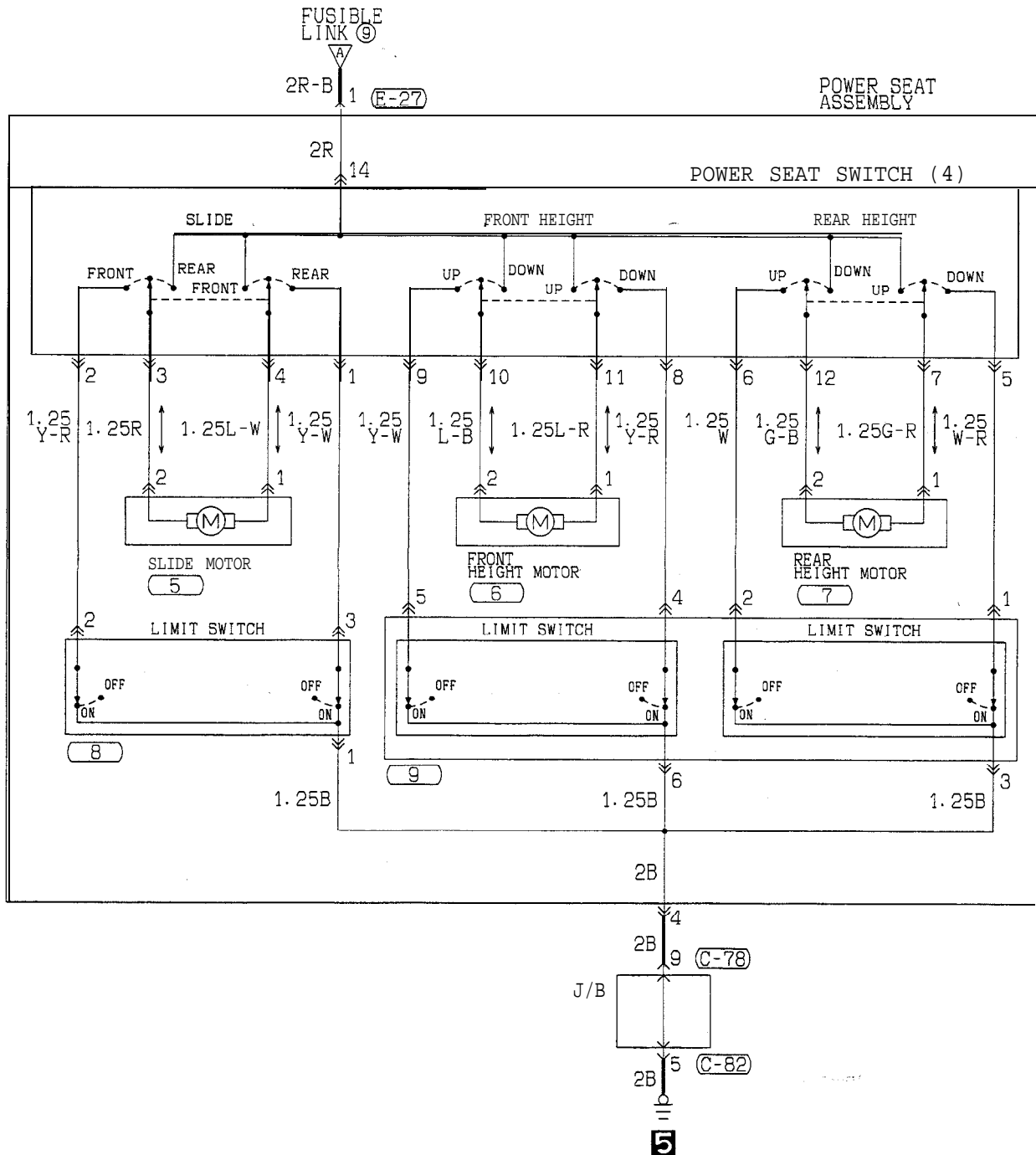

COMPONENT LOCATION

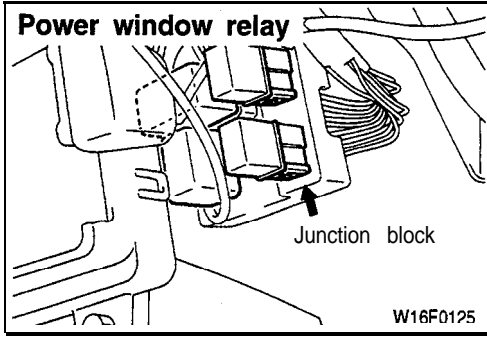

# TENSION-REDUCER TYPE SEAT BELT CIRCUIT (UP TO 1994 MODELS)

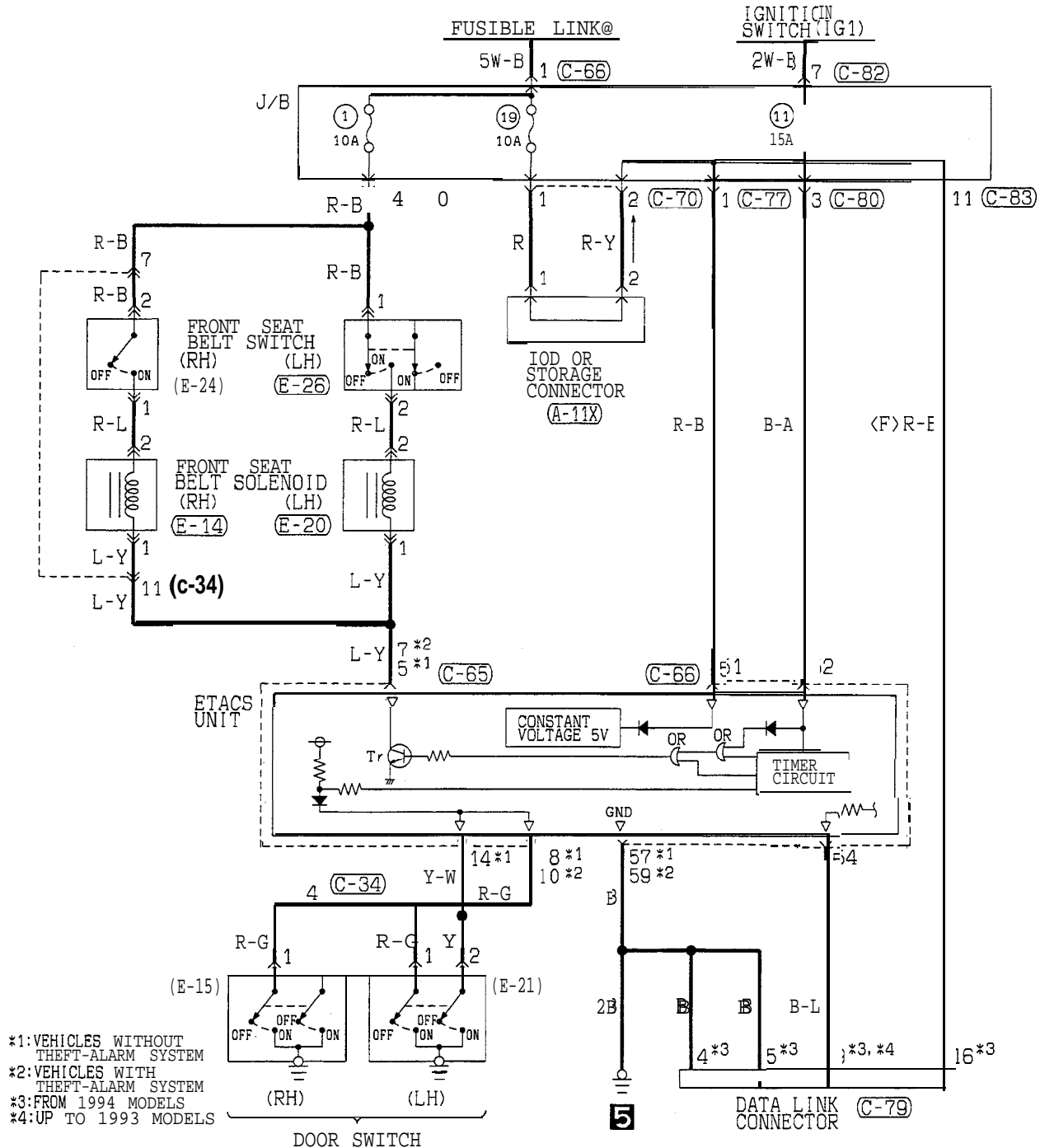

- \*1: VEHICLES WITHOUT THEFT-ALARM SYSTEM
- \*2: VEHICLES WITH THEFT-ALARM SYSTEM
- \*3: FROM 1994 MODELS
- \*4: UP TO 1993 MODELS

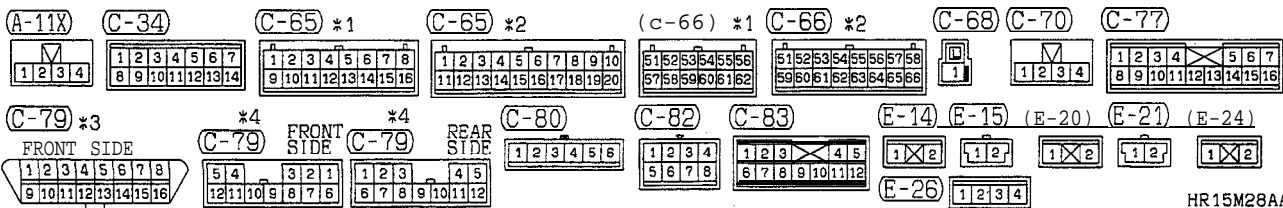

HR15M28AA

**TSB Revision**

**TENSION-REDUCER TYPE SEAT BELT CIRCUIT  
(FROM 1995 MODELS)**

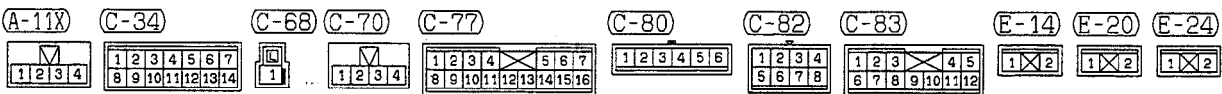
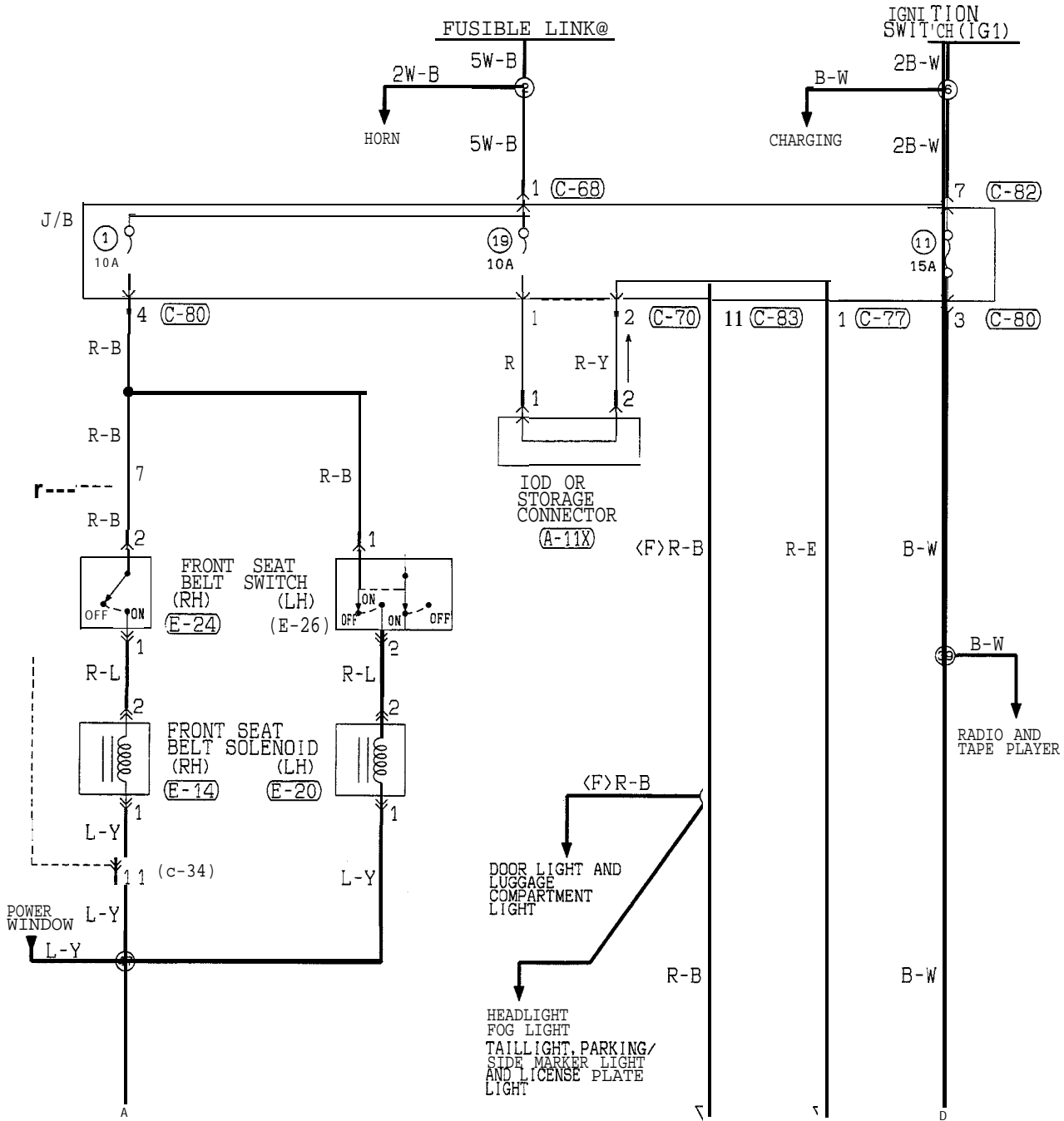

TSB Revision

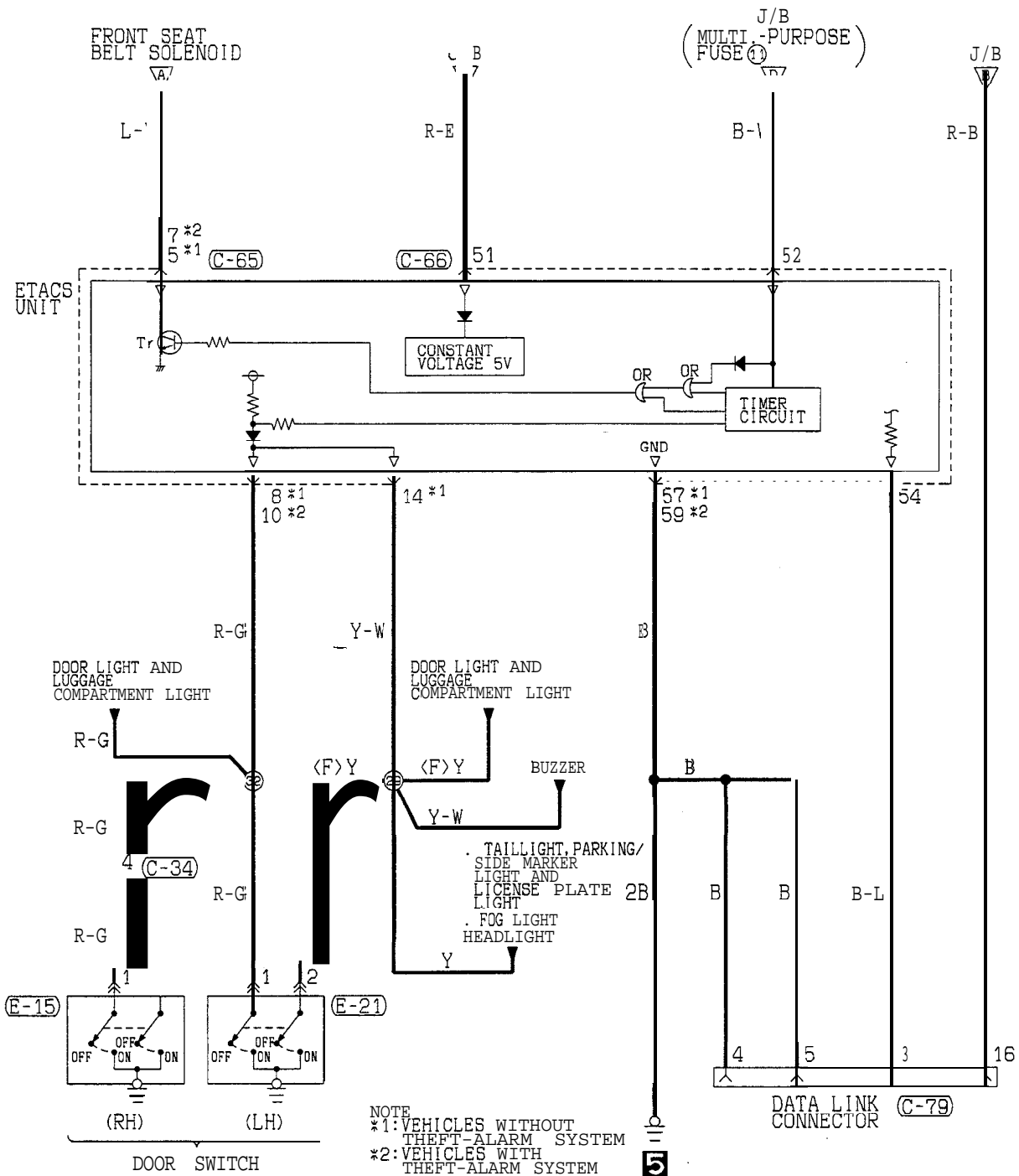

<b>C-34</b>	<b>C-65</b> *1	<b>C-65</b> *2	<b>C-66</b> *1	<b>C-66</b> *2	<b>C-79</b> FRONT SIDE (E-15) (E-21)																																																																																																								
<table border="1"> <tr><td>1</td><td>2</td><td>3</td><td>4</td><td>5</td><td>6</td><td>7</td></tr> <tr><td>8</td><td>9</td><td>10</td><td>11</td><td>12</td><td>13</td><td>14</td></tr> </table>	1	2	3	4	5	6	7	8	9	10	11	12	13	14	<table border="1"> <tr><td>1</td><td>2</td><td>3</td><td>4</td><td>5</td><td>6</td><td>7</td><td>8</td></tr> <tr><td>9</td><td>10</td><td>11</td><td>12</td><td>13</td><td>14</td><td>15</td><td>16</td></tr> </table>	1	2	3	4	5	6	7	8	9	10	11	12	13	14	15	16	<table border="1"> <tr><td>1</td><td>2</td><td>3</td><td>4</td><td>5</td><td>6</td><td>7</td><td>8</td><td>9</td><td>10</td></tr> <tr><td>11</td><td>12</td><td>13</td><td>14</td><td>15</td><td>16</td><td>17</td><td>18</td><td>19</td><td>20</td></tr> </table>	1	2	3	4	5	6	7	8	9	10	11	12	13	14	15	16	17	18	19	20	<table border="1"> <tr><td>51</td><td>52</td><td>53</td><td>54</td><td>55</td><td>56</td><td>57</td><td>58</td></tr> <tr><td>59</td><td>60</td><td>61</td><td>62</td><td>63</td><td>64</td><td>65</td><td>66</td></tr> </table>	51	52	53	54	55	56	57	58	59	60	61	62	63	64	65	66	<table border="1"> <tr><td>51</td><td>52</td><td>53</td><td>54</td><td>55</td><td>56</td><td>57</td><td>58</td></tr> <tr><td>59</td><td>60</td><td>61</td><td>62</td><td>63</td><td>64</td><td>65</td><td>66</td></tr> </table>	51	52	53	54	55	56	57	58	59	60	61	62	63	64	65	66	<table border="1"> <tr><td>1</td><td>2</td><td>3</td><td>4</td><td>5</td><td>6</td><td>7</td><td>8</td></tr> <tr><td>9</td><td>10</td><td>11</td><td>12</td><td>13</td><td>14</td><td>15</td><td>16</td></tr> </table>	1	2	3	4	5	6	7	8	9	10	11	12	13	14	15	16	<table border="1"> <tr><td>1</td><td>2</td></tr> </table>	1	2	<table border="1"> <tr><td>1</td><td>2</td></tr> </table>	1	2
1	2	3	4	5	6	7																																																																																																							
8	9	10	11	12	13	14																																																																																																							
1	2	3	4	5	6	7	8																																																																																																						
9	10	11	12	13	14	15	16																																																																																																						
1	2	3	4	5	6	7	8	9	10																																																																																																				
11	12	13	14	15	16	17	18	19	20																																																																																																				
51	52	53	54	55	56	57	58																																																																																																						
59	60	61	62	63	64	65	66																																																																																																						
51	52	53	54	55	56	57	58																																																																																																						
59	60	61	62	63	64	65	66																																																																																																						
1	2	3	4	5	6	7	8																																																																																																						
9	10	11	12	13	14	15	16																																																																																																						
1	2																																																																																																												
1	2																																																																																																												



COMPONENT LOCATION

Name	Symbol	Name	Symbol
Data link connector (from 1994 models)	C	ETACS unit	A
Data link connector (up to 1993 models)	B	Front seat belt solenoid	D

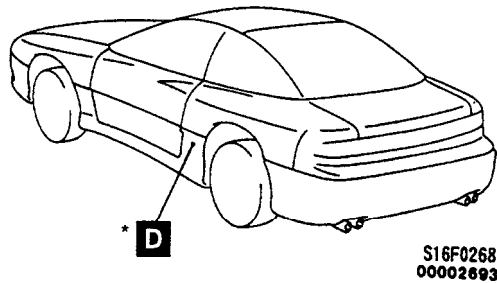
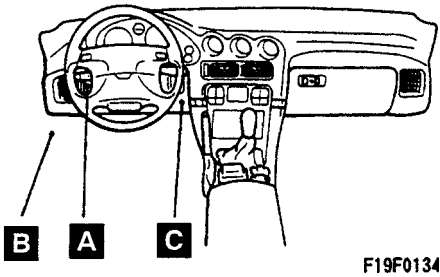

Note: \* indicates that this component is used on the right side as well.

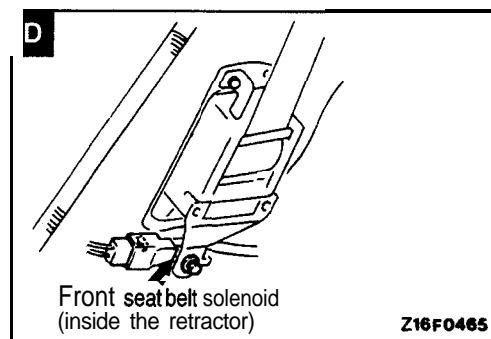
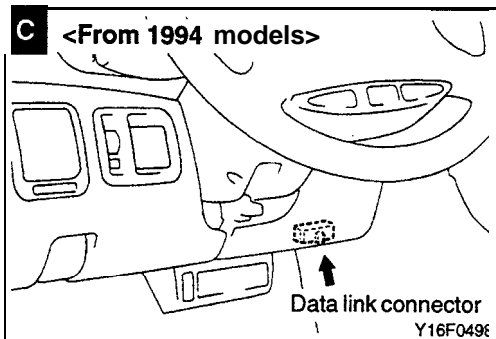
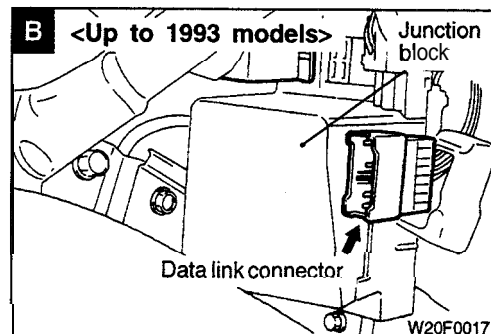
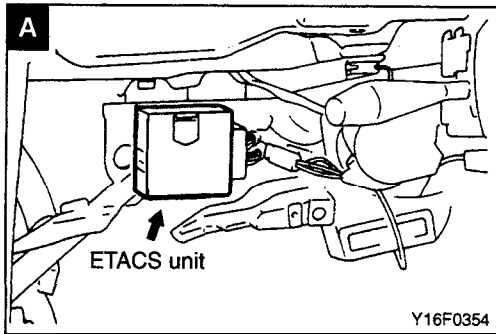

**OPERATION**

- If the driver fastens the seat belt with the ignition switch placed in the “ON” position, the seat belt switch in the seat belt buckle is turned “ON” to operate the seat belt solenoid in the retractor.
- This will reduce the seat belt rewinding torque to minimize a sense of oppression given by the belt.
- Owing to the timer function of the ETACS unit, the seat belt solenoid is kept in operation for 30 seconds after turning off the ignition switch, with due consideration to elimination of the sudden rise in a sense of oppression caused by the belt immediately after the ignition switch is turned off.

**TROUBLESHOOTING HINTS**

Phenomenon	Inspection method
Some of the tension-reducers do not operate.	<ul style="list-style-type: none"> <li>• Check dedicated fuse No. 1 and 19.</li> <li>• Check the inoperative seat belt switch.</li> <li>• Check the inoperative seat belt solenoid.</li> </ul>
The tension-reducer does not operate with the ignition switch placed in the ON position.	<ul style="list-style-type: none"> <li>• Check the ignition switch input signal.</li> <li>• Check the ignition switch. (Refer to GROUP 54–Ignition switch.)</li> </ul>
The tension-reducer is in operation immediately after the ignition switch is turned off, but it does not stop operation even if the door is opened within 30 seconds from the turning-off the ignition switch.	<ul style="list-style-type: none"> <li>• Check the door switch input signal.</li> <li>• Check the door switch. (Refer to GROUP 42–Door Assembly.)</li> </ul>

ACTIVE AERO CIRCUIT (UP TO 1993 MODELS)

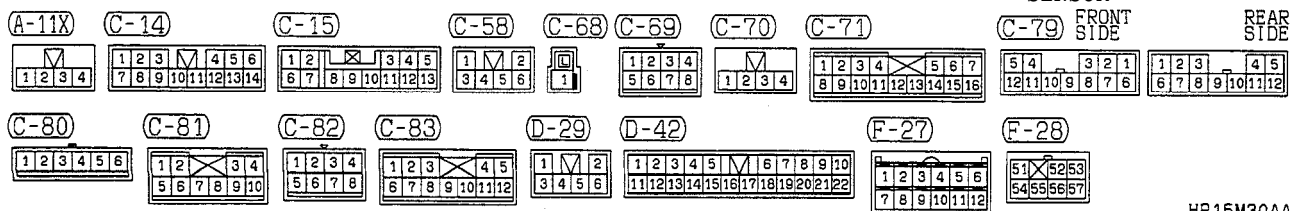
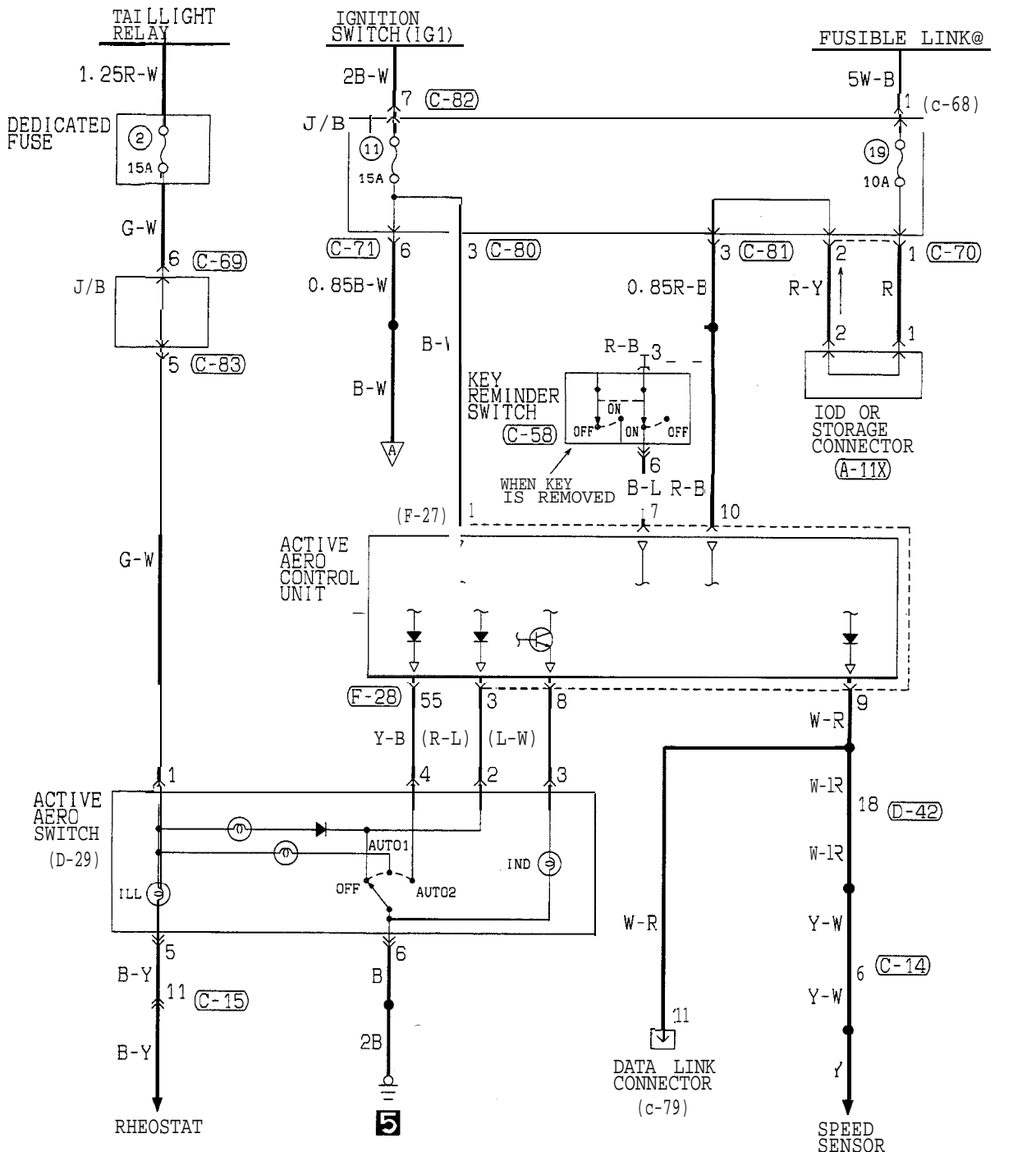

TSB Revision

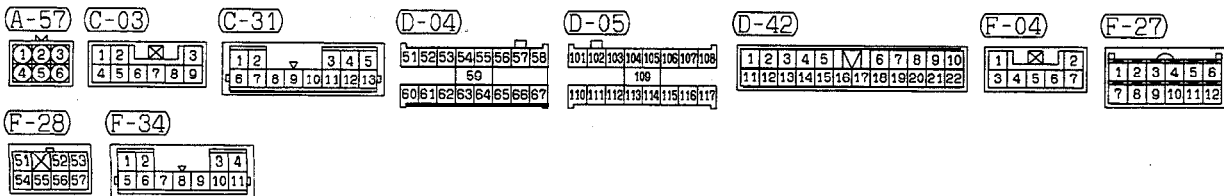
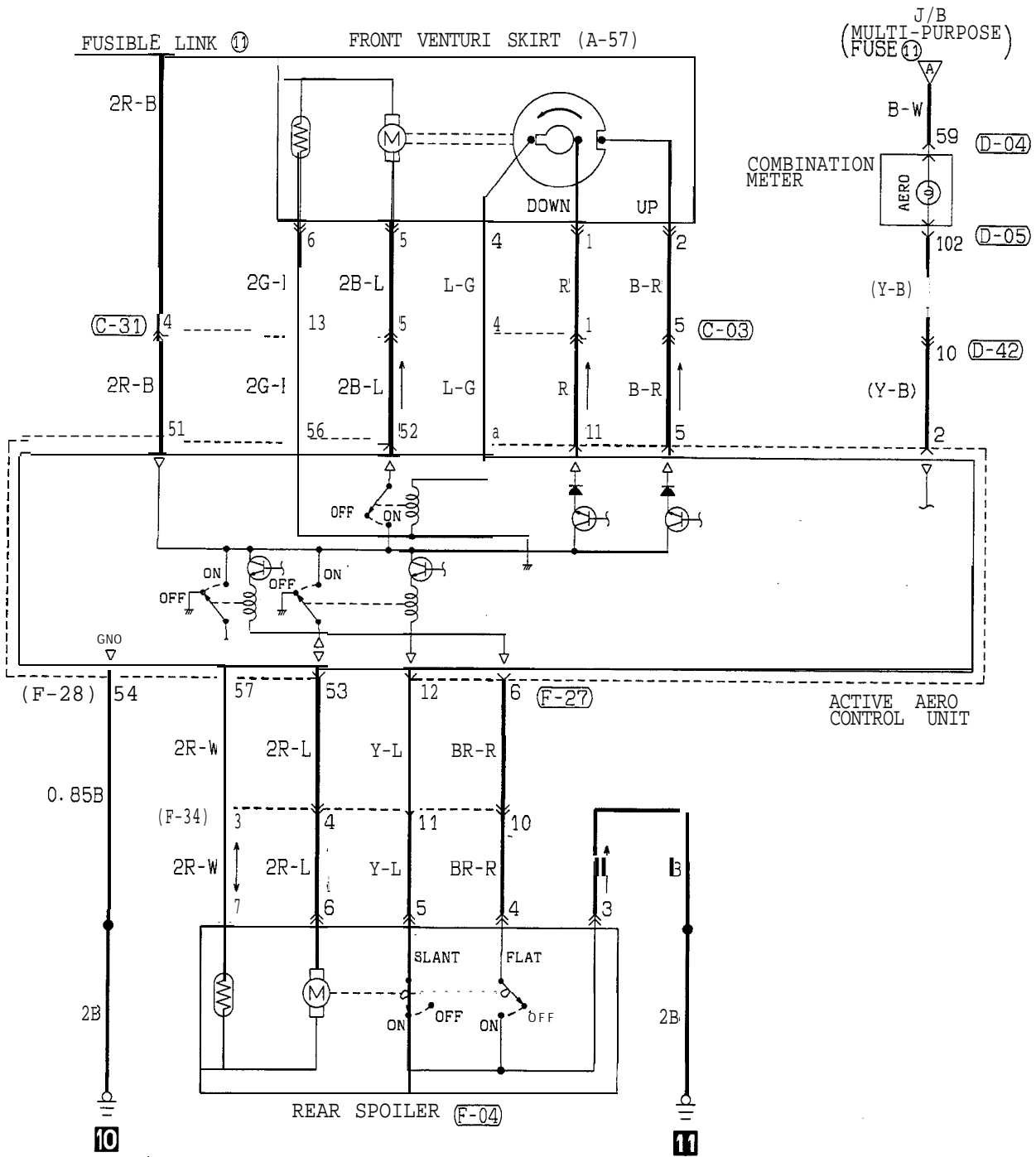

ACTIVE AERO CIRCUIT (FROM 1994 MODELS)

<HATCHBACK>

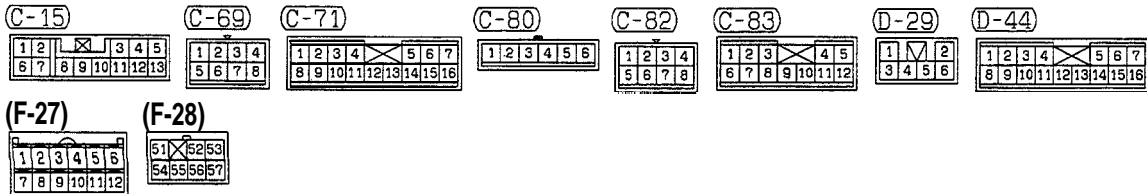
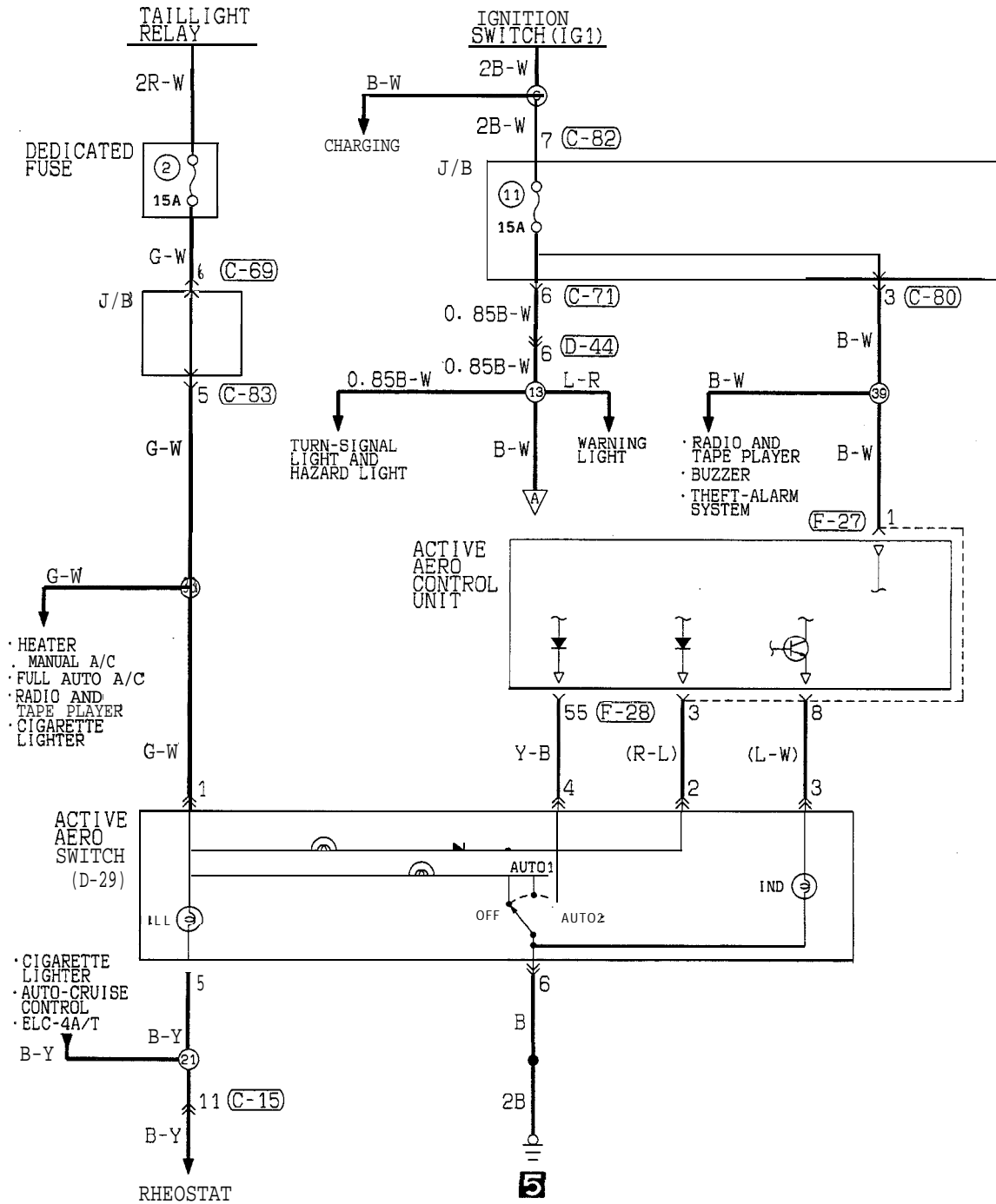

TSB Revision

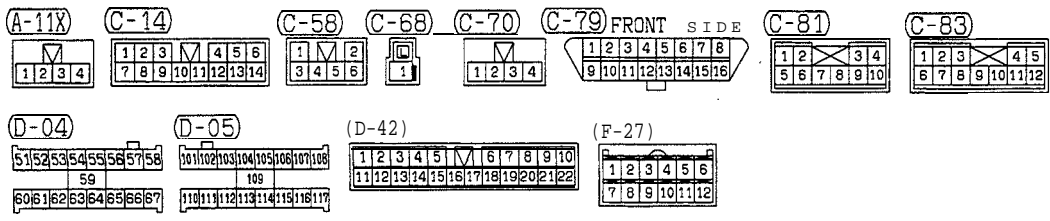
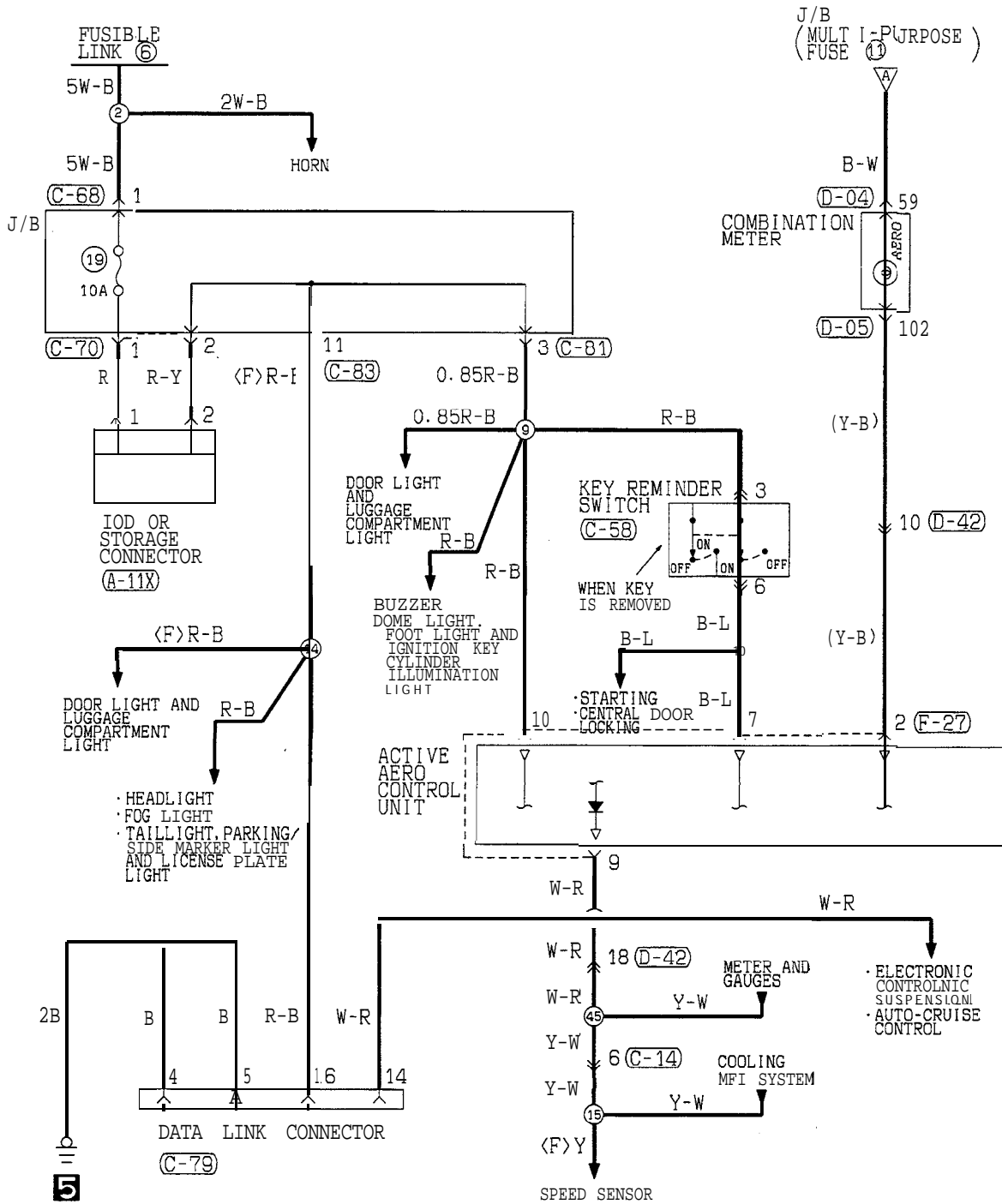

TSB Revision

ACTIVE AERO CIRCUIT (FROM 1994 MODELS) (CONTINUED)

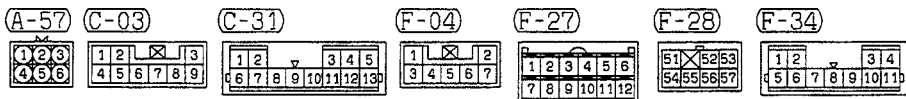
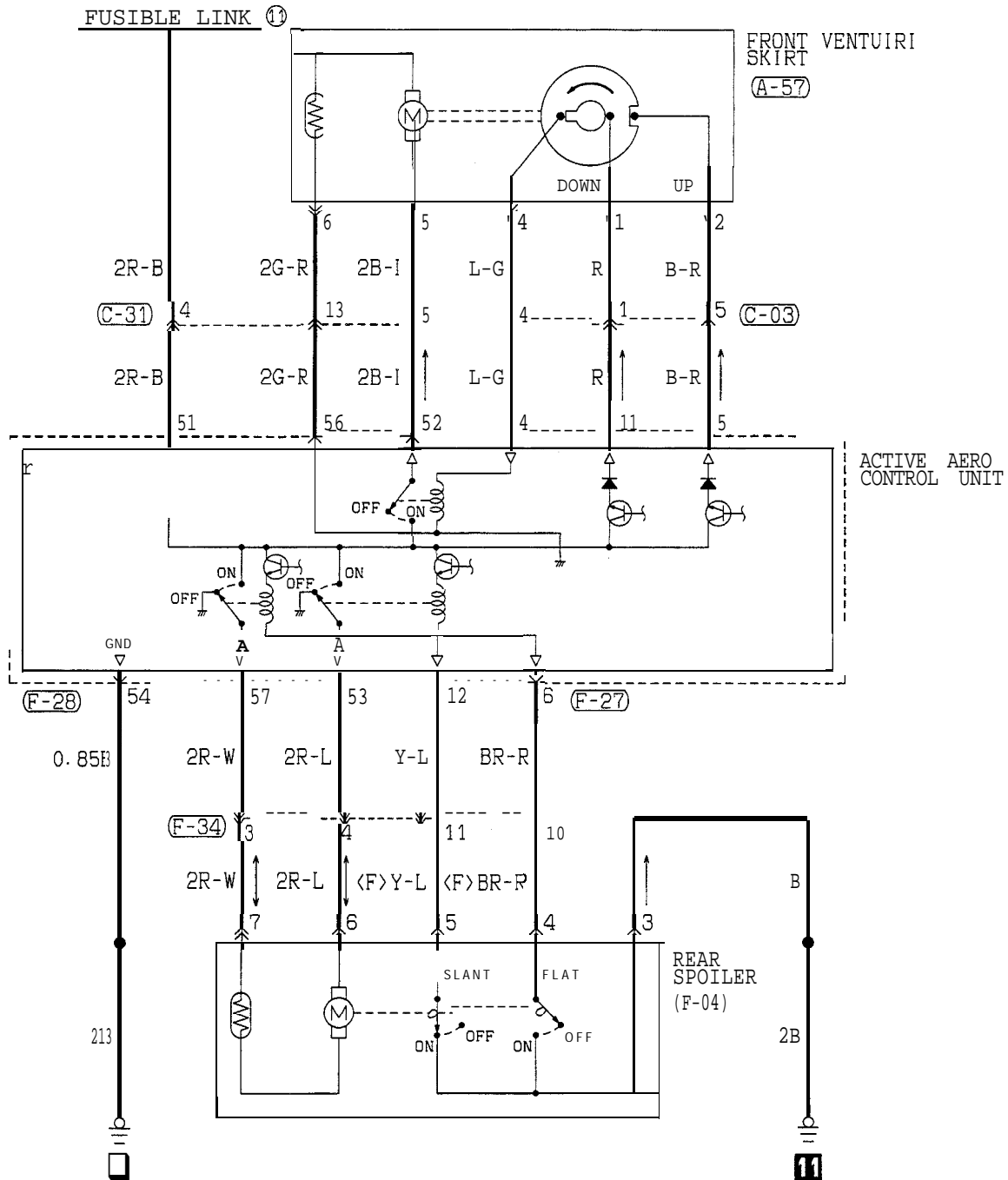

COMPONENT LOCATION

Name	Symbol	Name	Symbol
Active aero control unit	E	Data link connector (from 1994 models)	B
Active aero front venturi skirt	C	Data link connector (up to 1993 models)	A
Active aero rear spoiler	D		

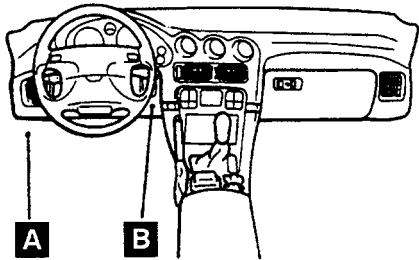

E19F0134

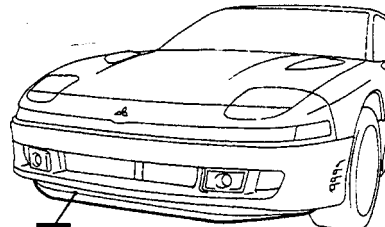

Z18F0325

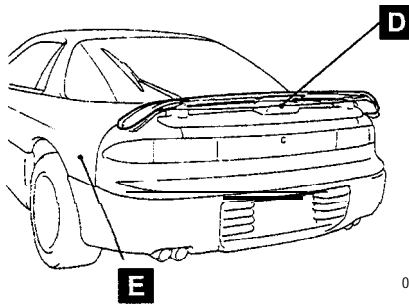

Z18F0233  
00002694

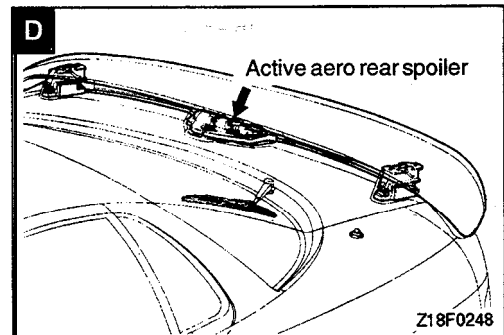
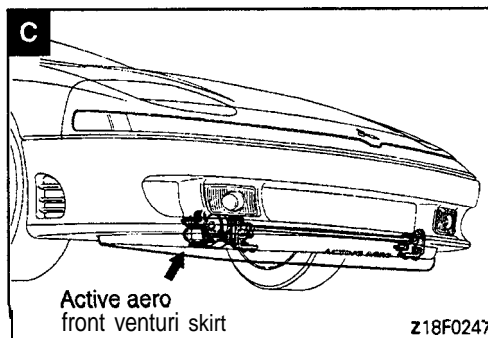
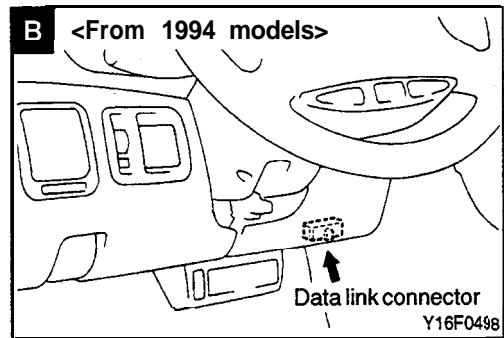
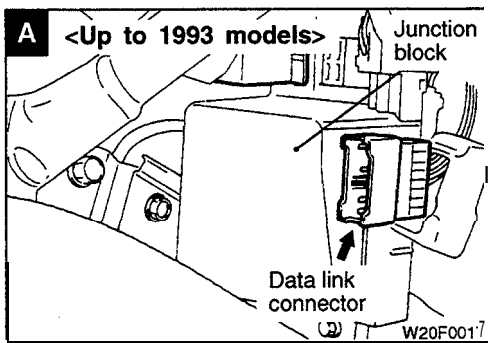



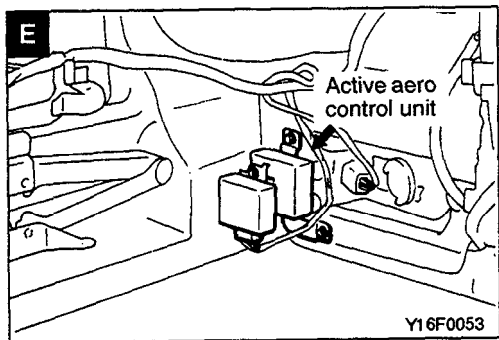

# CAR TELEPHONE CIRCUIT (1992 MODEL)

(VEHICLES HARNESS WITHOUT TELEPHONE COMPONENT)

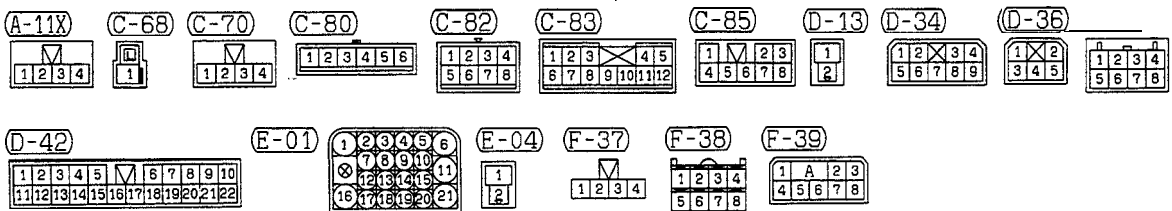
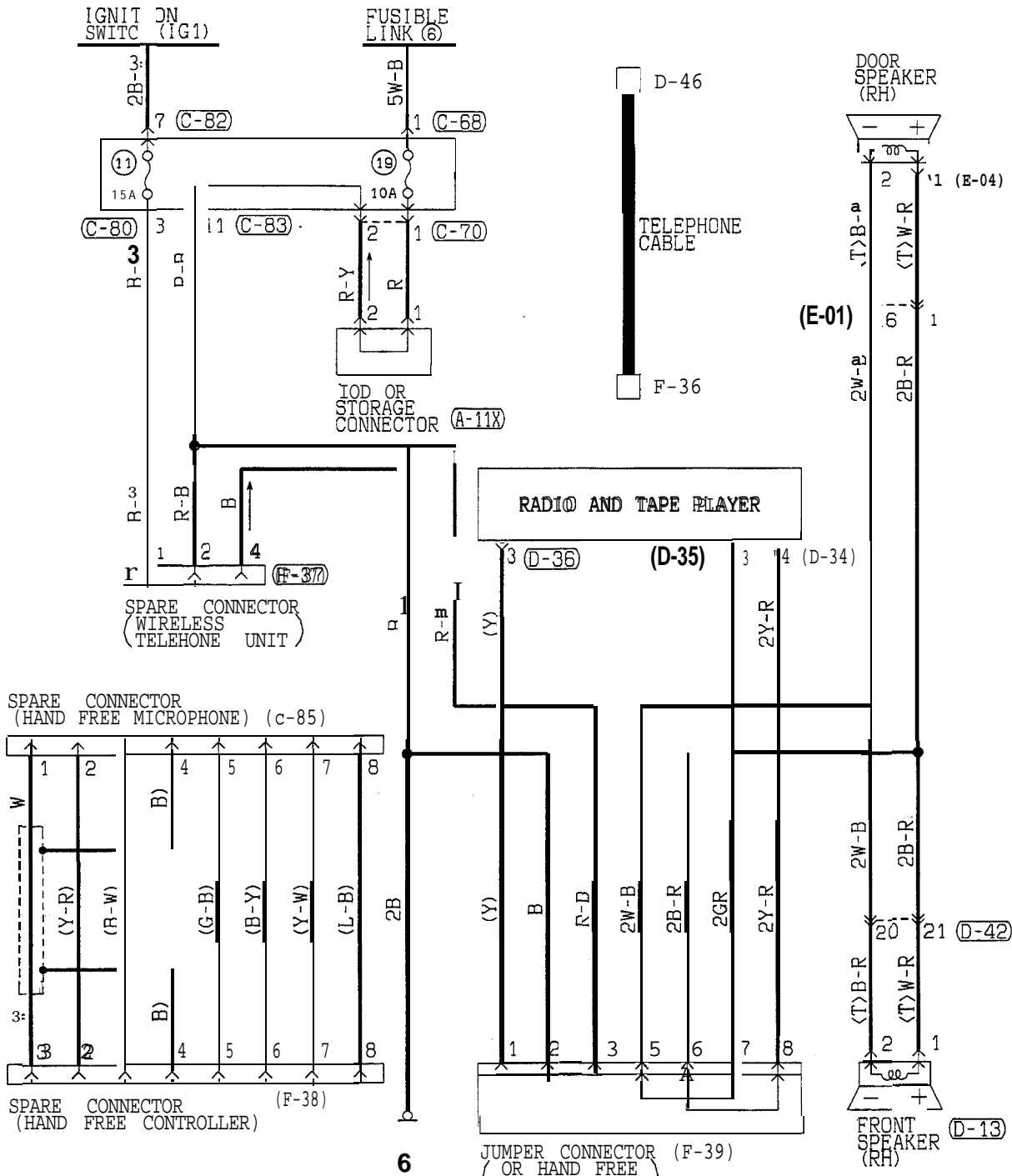

**CAR TELEPHONE CIRCUIT (1993 Models)**

(VEHICLES HARNESS WITHOUT TELEPHONE COMPONENT)

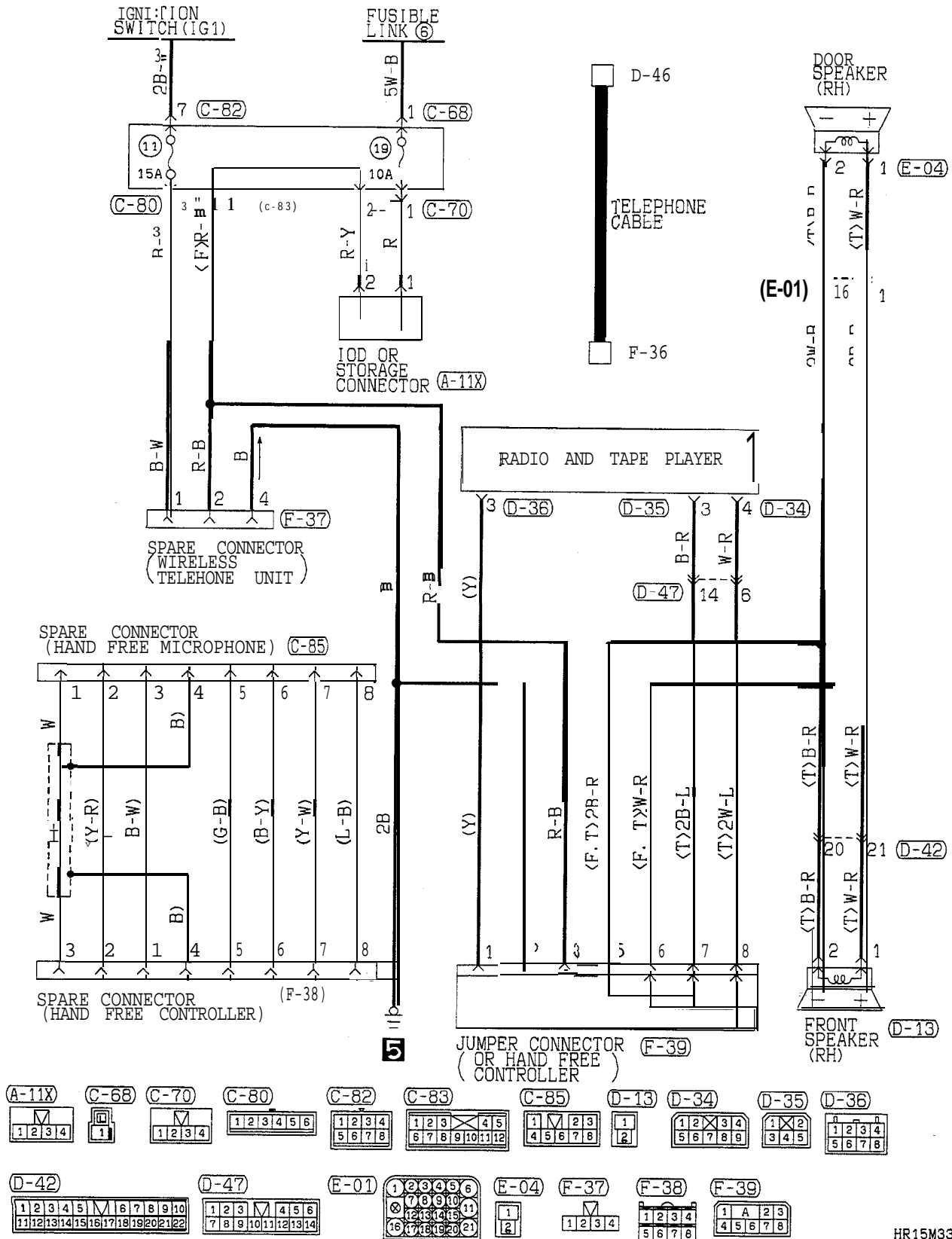

- A-11X  

M			
1	2	3	4
- C-68  

1
---
- C-70  

M			
1	2	3	4
- C-80  

1	2	3	4	5	6
---	---	---	---	---	---
- C-82  

1	2	3	4
5	6	7	8
- C-83  

1	2	3	4	5
6	7	8	9	10
11	12			
- C-85  

1	M	2	3
4	5	6	7
8			
- D-13  

1
2
- D-34  

1	2	3	4
5	6	7	8
9			
- D-35  

1	X	2
3	4	5
- D-36  

1	2	3	4
5	6	7	8
- D-42  

1	2	3	4	5	6	7	8	9	10
11	12	13	14	15	16	17	18	19	20
21	22								
- D-47  

1	2	3	4	5	6
7	8	9	10	11	12
13	14	15			
- E-01  

1	2	3	4	5	6
7	8	9	10	11	12
13	14	15	16	17	18
19	20	21			
- E-04  

1
2
- F-37  

1	2	3	4
---	---	---	---
- F-38  

1	A	2	3
4	5	6	7
8			
- F-39  

1	A	2	3
4	5	6	7
8			

TSB Revision

---

NOTES

TOP STACK CIRCUIT (1995 MODELS)

<CONVERTIBLE>

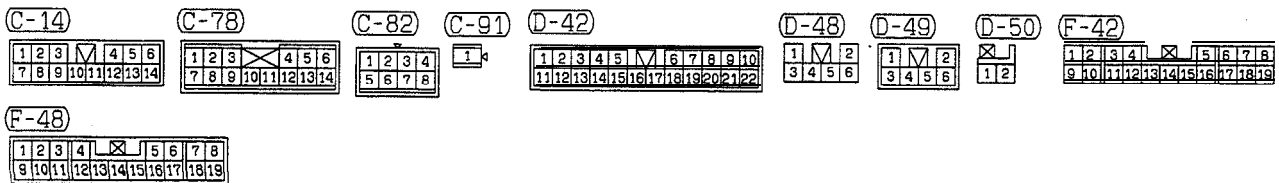
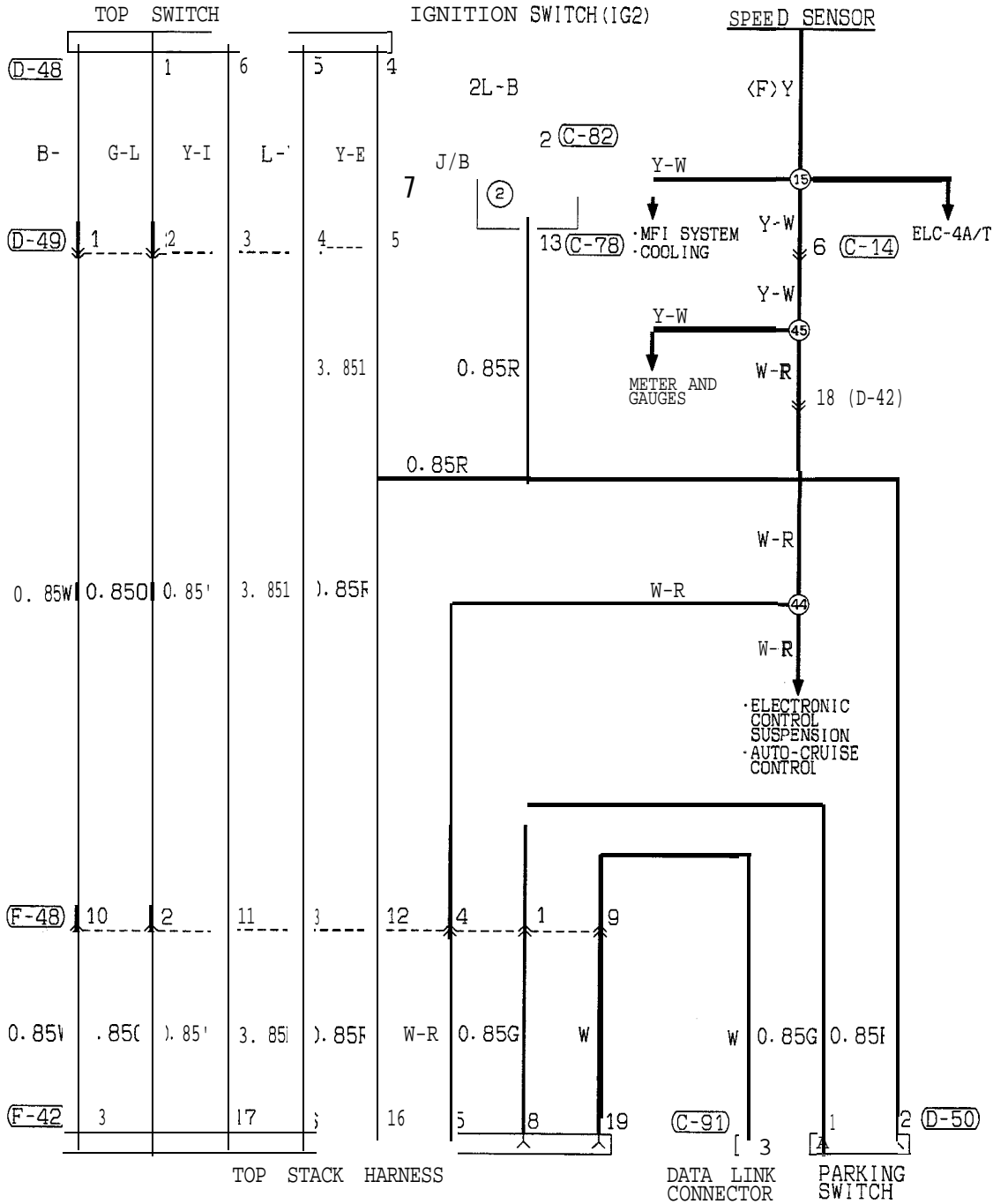

TSB Revision

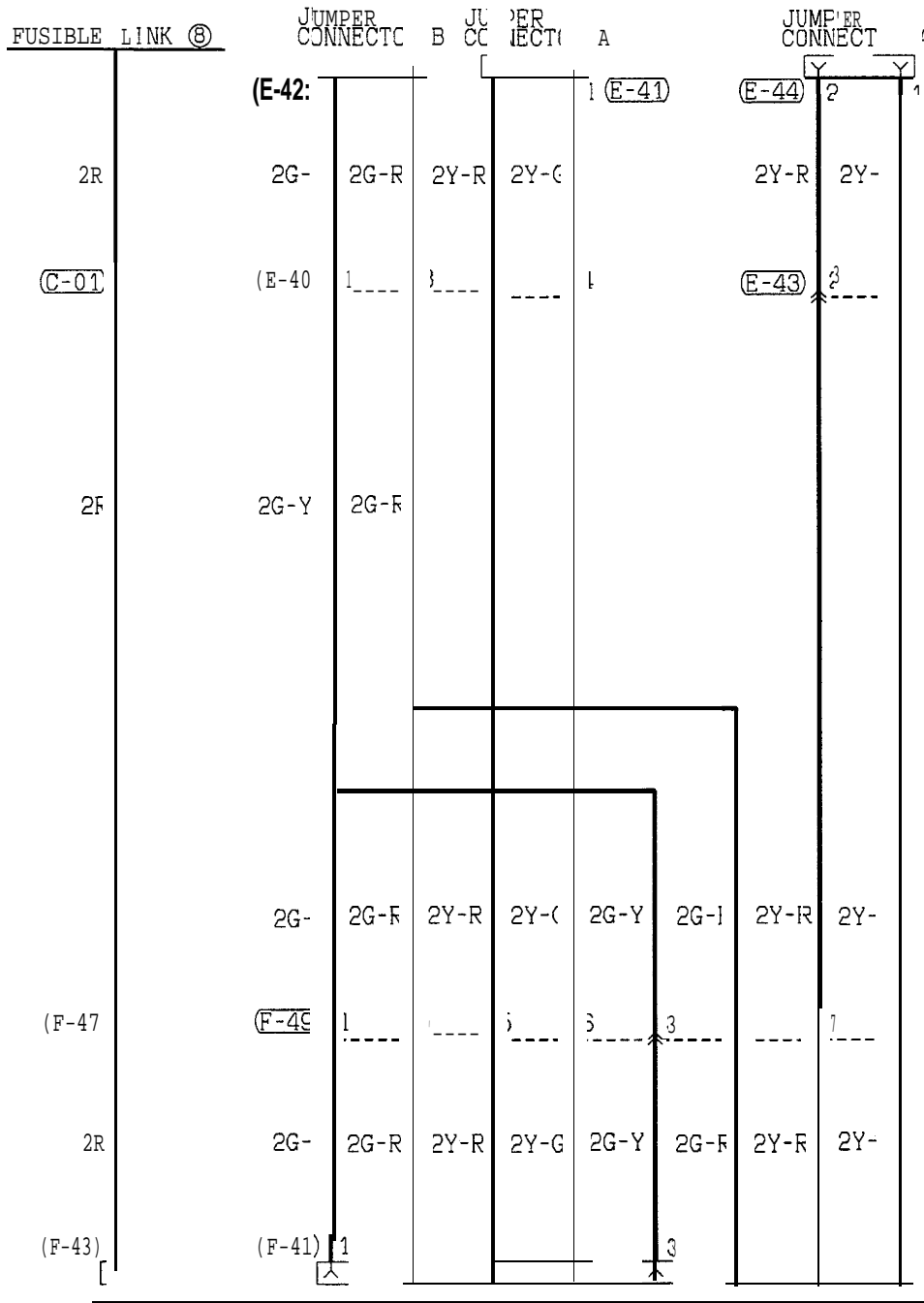

TOP STACK HARNESS

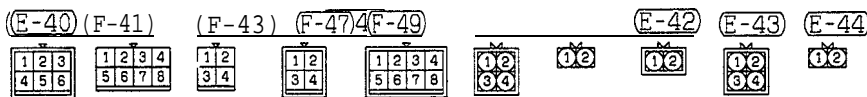

TOP STACK CIRCUIT (FROM 1996 MODELS)

<CONVERTIBLE>

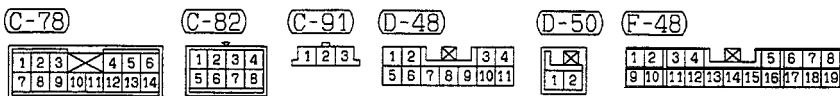
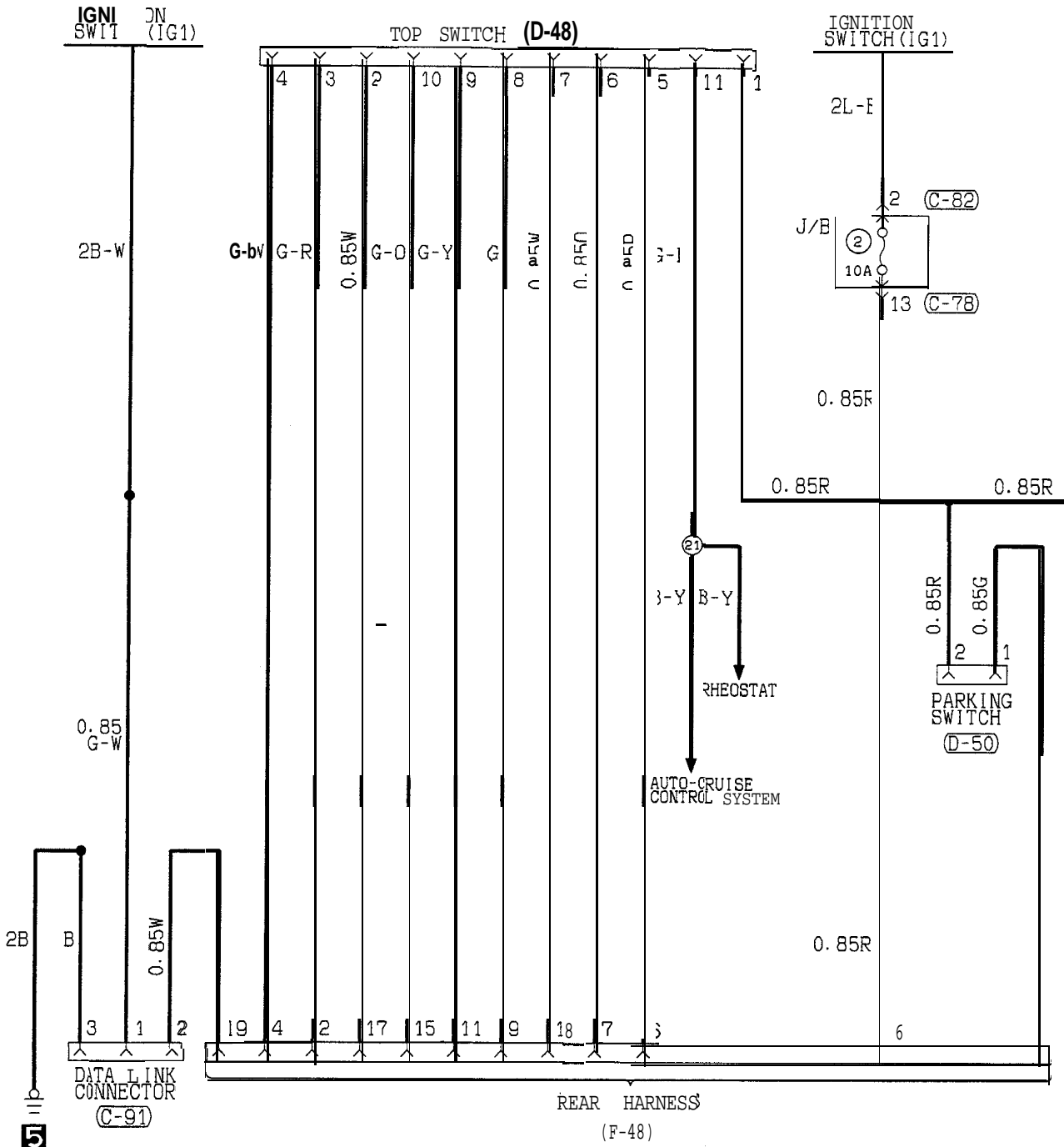

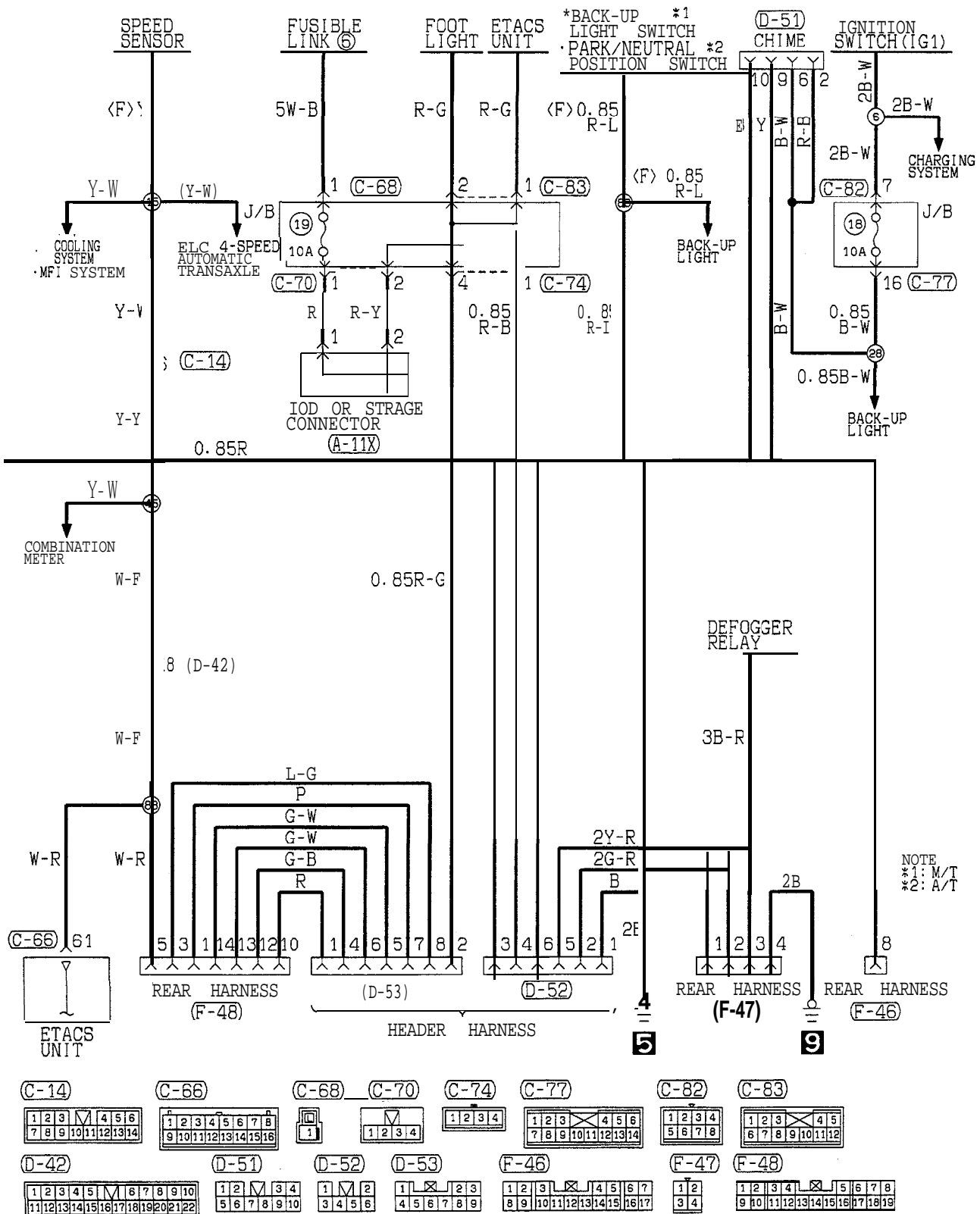

HR15M39AB

TSB Revision



**SUNROOF CIRCUIT (FROM 1995 MODELS)**

<HATCHBACK>

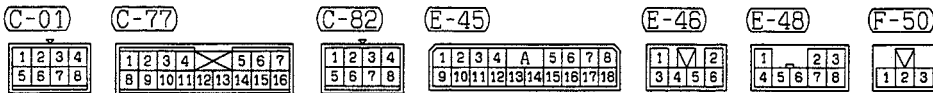
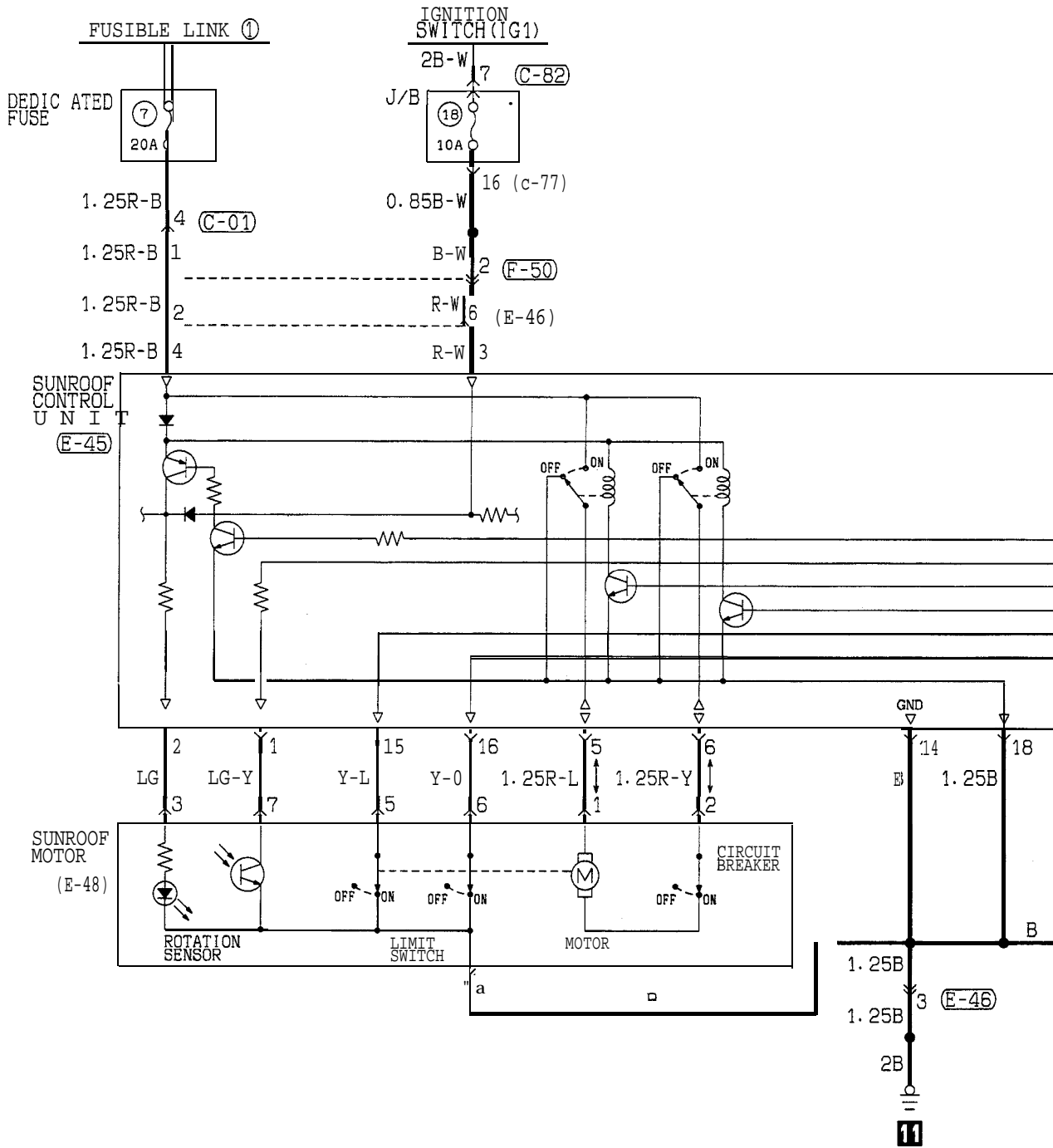

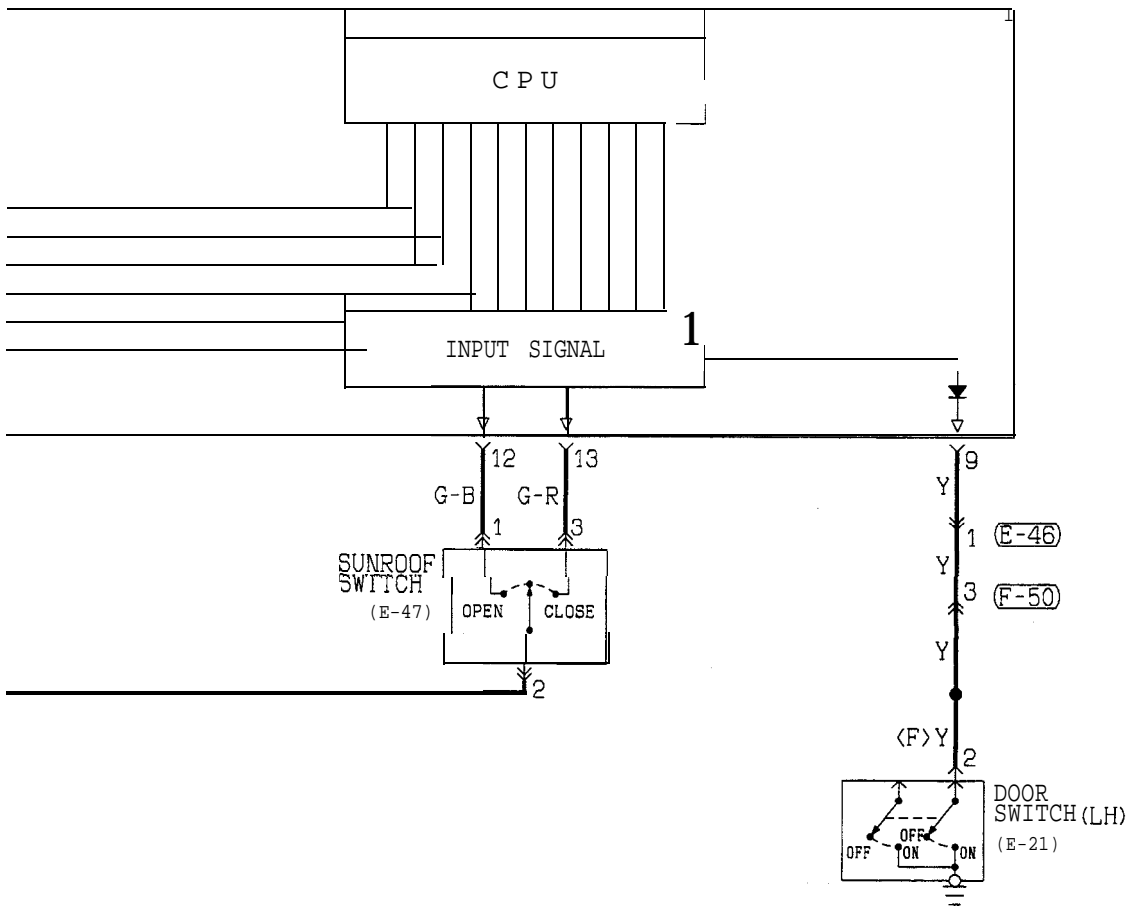

- E-21 

M
1 2
- E-46 

1	M	2
3	4	5 6
- E-47 

L	X	J
1	2	3
- F-50 

M
1 2 3

TSB Revision

---

NOTES



# ENGINE ELECTRICAL

## CONTENTS

<b>CHARGING SYSTEM</b> .....	<b>2</b>		
<b>GENERATOR</b> . . . . *	<b>12</b>		
<b>ON-VEHICLE SERVICE</b> .....	<b>6</b>		
Generator Output Line Voltage Drop Test .....	6		
Output Current Test .....	7		
Regulated Voltage Test .....	9		
Wave-form Check Using An Analyzer .....	10		
<b>SPECIFICATIONS</b> .....	<b>2</b>		
General Specifications .....	2		
Service Specifications .....	2		
<b>TROUBLESHOOTING</b> .....	<b>3</b>		
<b>IGNITION SYSTEM</b> .....	<b>31</b>		
<b>IGNITION SYSTEM</b> .....	<b>45</b>		
<b>ON-VEHICLE SERVICE</b> .....	<b>36</b>		
Crankshaft Position Sensor Check .....	Refer to GROUP 13A (ON-VEHICLE INSPECTION OF MFI COMPONENTS)		
		Ignition Primary Voltage Wave-form Check .....	41
		Ignition Secondary Voltage Wave-form Check .....	37
		Ignition Timing Adjustment . . . Refer to GROUP	11
		Spark Plug Cable Test .....	36
		Spark Plug Test .....	36
		<b>SPECIAL TOOLS</b> .....	<b>31</b>
		<b>SPECIFICATIONS</b> .....	<b>31</b>
		General Specifications .....	31
		Service Specifications .....	31
		<b>TROUBLESHOOTING</b> .....	<b>32</b>
		<b>STARTING SYSTEM</b> .....	<b>19</b>
		<b>SPECIFICATIONS</b> .....	<b>19</b>
		General Specifications .....	19
		Service Specifications .....	19
		<b>STARTER MOTOR</b> .....	<b>23</b>
		<b>TROUBLESHOOTING</b> .....	<b>20</b>

**CHARGING SYSTEM****SPECIFICATIONS****GENERAL SPECIFICATIONS****GENERATOR**

Items	Up to 1995 models	From 1996 models
Type	Battery voltage sensing	Battery voltage sensing
Rated output VIA	12/110	12/95
Voltage regulator	Electronic type	Electronic type

**SERVICE SPECIFICATIONS****GENERATOR**

Items	Standard value	Limit	
Regulated voltage Ambient temp. at voltage regulator V	-20°C (-4°F)	14.2-15.4	-
	20°C (68°F)	13.9-14.9	-
	60°C (140°F)	13.4-14.6	-
	80°C (176°F)	13.1-14.5	-
Slip ring O.D. mm (in.)	26.7 (1.05)	26.1 (1.03)	
Field coil resistance $\Omega$	Approx. 3-5	-	
Output current	-	/ 70% of nominal output current	

**TROUBLESHOOTING  
(UP TO 1993 MODELS)**

**CIRCUIT DIAGRAM**

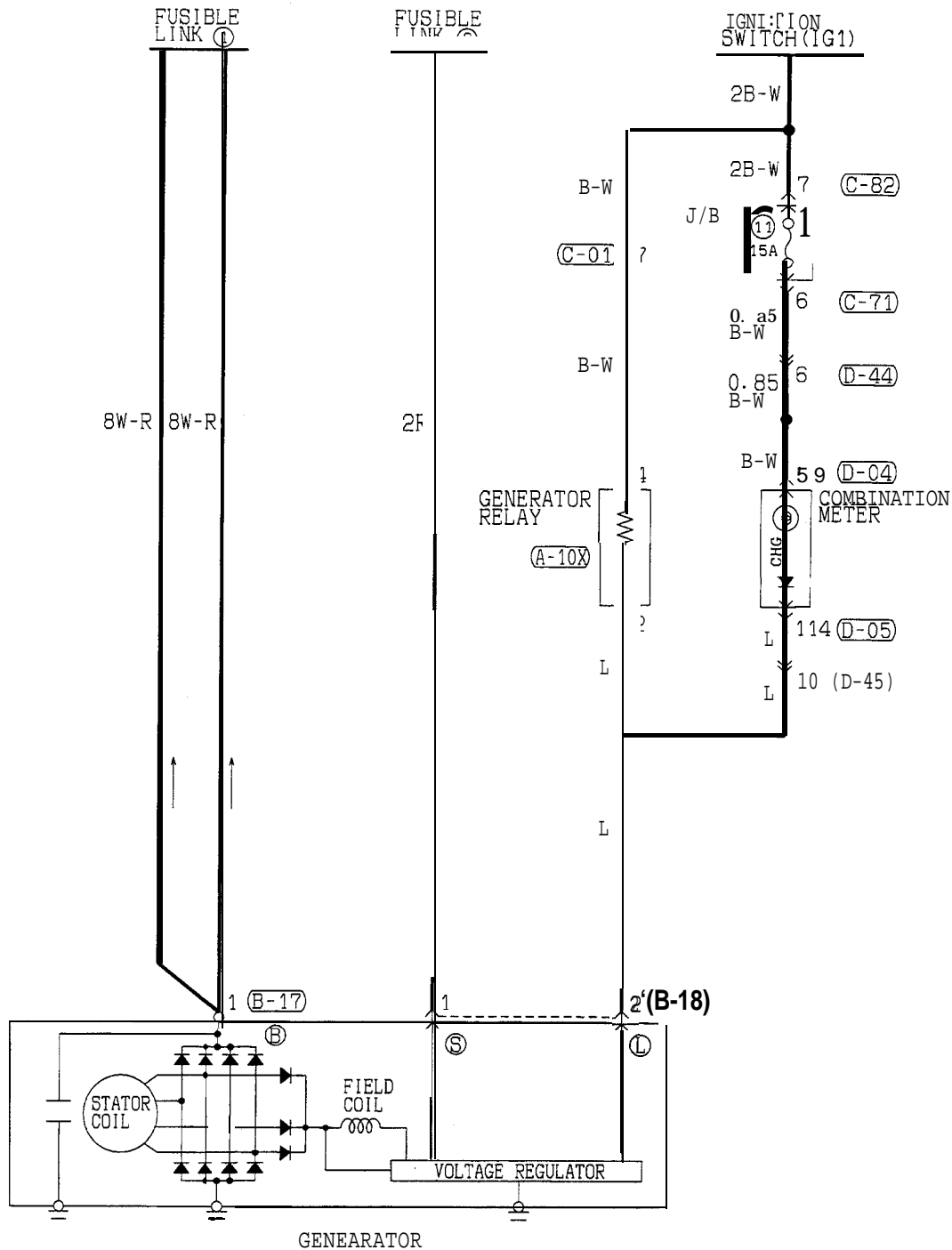

- A-10X  

1	2	3	4
5	6	7	8
- B-17  

1
---
- B-18  

2
---
- C-01  

1	2	3	4
5	6	7	8
- C-71  

1	2	3	4	5	6	7		
8	9	10	11	12	13	14	15	16
- C-82  

1	2	3	4
5	6	7	8
- D-04  

5	15	25	35	45	55	65	75	85
95	105	115	125	135	145	155	165	175
- D-05  

101	102	103	104	105	106	107	108	
109	110	111	112	113	114	115	116	117
- D-44  

1	2	3	4	5	6	7		
8	9	10	11	12	13	14	15	16
- D-45  

1	2	3	4	5	6			
7	8	9	10	11	12	13	14	15

TSB Revision

(FROM 1994 MODELS)

CIRCUIT DIAGRAM

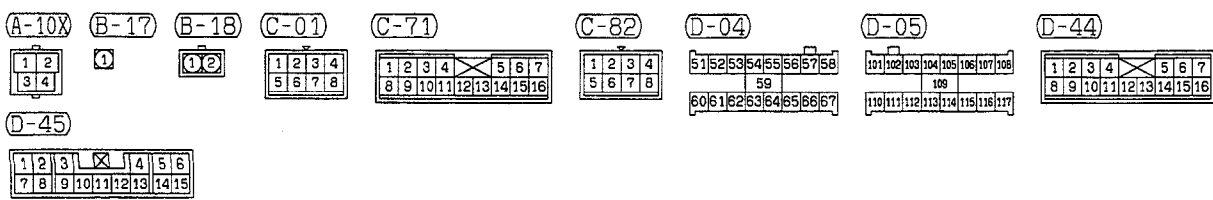
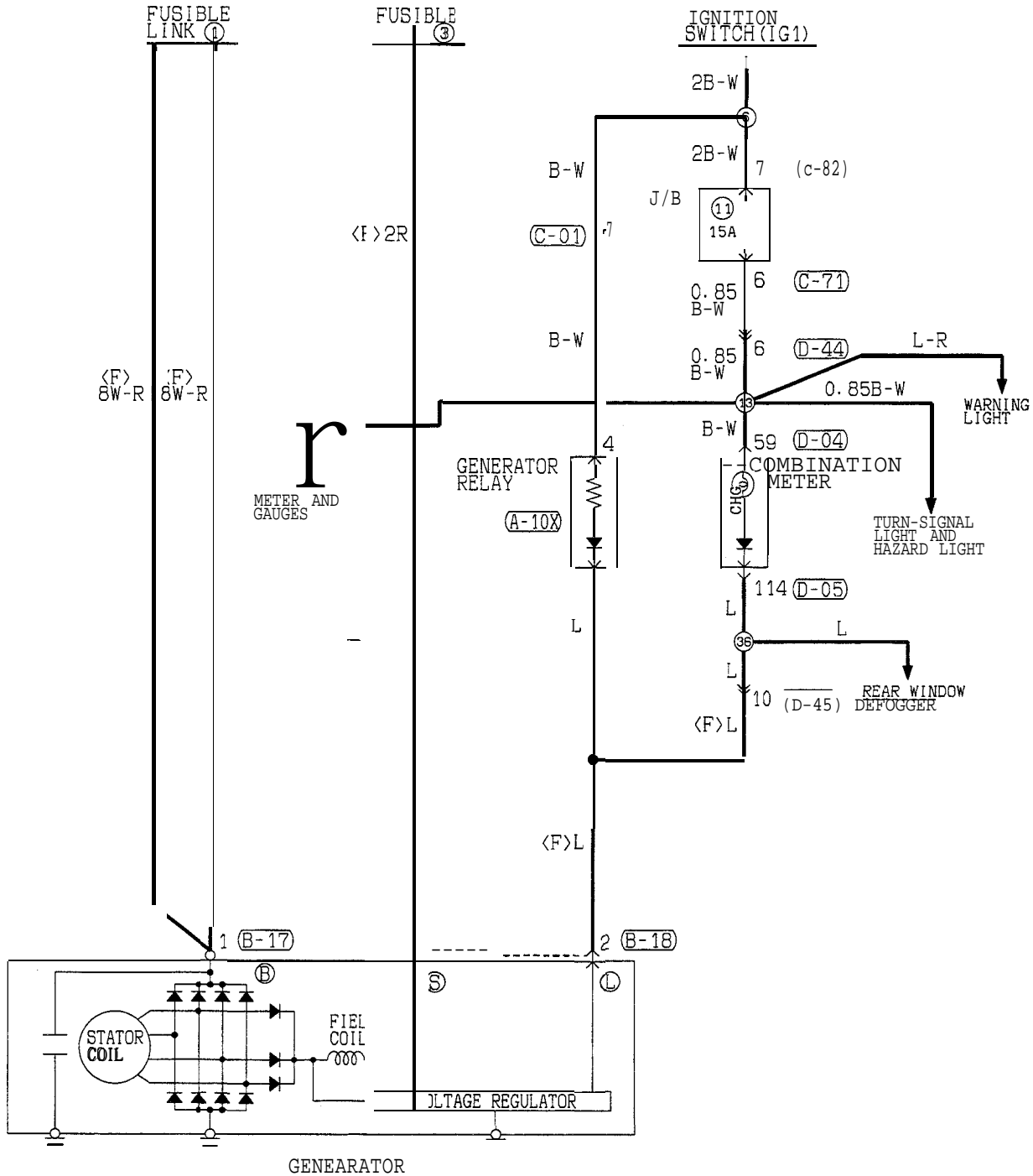

**OPERATION**

**When engine is stopped**

When the ignition switch is switched to the “ON” position, electricity flows from the “L” terminal of the generator to the field coil, and at the same time the charging warning light illuminates.

**When engine is being started/has started**

When the engine is started, charging voltage is applied to the “L” terminal of the generator, with the result that the charging warning light is extinguished. In addition, because battery voltage is applied to the “S” terminal of the generator, this battery voltage is monitored at the IC voltage regulator, thus switching ON and OFF the current to the field coil and thereby controlling the output voltage of the generator.

Power is supplied to each load from the “B” terminal of the generator.

**NOTE**

The generator relay functions as a back-up for the flow of electricity to the field coil if there is a disconnection or damaged wiring of the charging warning light.

**TROUBLESHOOTING HINTS**

1. Charging warning light does not go on when the ignition switch is turned to “ON”, before the engine starts.
  - Check the bulb.
2. Charging warning light fails to go off once the engine starts.
  - Check the IC voltage regulator (located within the generator).
3. Discharged or overcharged battery.
  - Check the IC voltage regulator (located within the generator).
4. The charging warning light illuminates dimly.
  - Check the diode (within the combination meter) for a short-circuit.

**COMPONENT LOCATION**

Name	Symbol
Generator relay	A

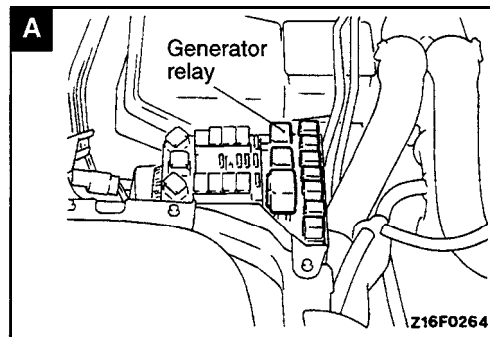
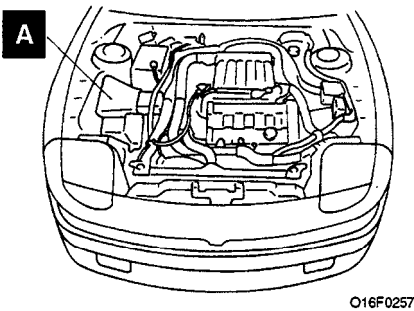



## ON-VEHICLE SERVICE

## GENERATOR OUTPUT LINE VOLTAGE DROP TEST

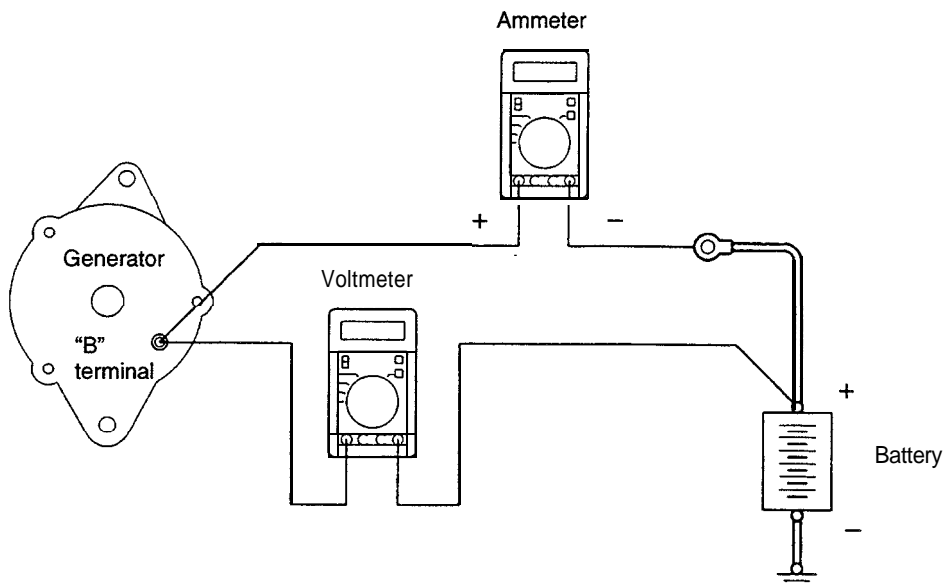

6EN0962

This test determines whether the wiring from the generator "B" terminal to the battery (+) terminal (including the fusible link) is in a good condition or not.

- (1) Always be sure to check the following before the test.
  - Generator installation
  - Generator drive belt tension (Refer to GROUP 00 – Maintenance Service.)
  - Fusible link
  - Abnormal noise from the generator while the engine is running
- (2) Turn the ignition switch to the OFF position.
- (3) Disconnect the negative battery cable.
- (4) Disconnect the generator output wire from the generator "B" terminal and connect a DC test ammeter with a range of 0 – 100 A in series between the "B" terminal and the disconnected output wire. (Connect the (+) lead of the ammeter to the "B" terminal, and then connect the

(–) lead of the ammeter to the disconnected output wire.)

## NOTE

A clamp-type ammeter which enables measurements to be taken without disconnecting the generator output wire is recommended. The reason for this is if a vehicle in which the voltage may have dropped due to an imperfect connection at the generator "B" terminal is being inspected, and the generator "B" terminal is loosened when the test ammeter is connected, the connection will be completed at this time and the possibility of finding problems will be reduced.

- (5) Connect a digital-type voltmeter between the generator "B" terminal and the battery (+) terminal. (Connect the (+) lead of the voltmeter to the "B" terminal, and then connect the (–) lead of the voltmeter to the battery (+) cable.)

- (6) Connect a tachometer. (For the procedure for connecting the tachometer, refer to GROUP 11 – On-vehicle Service.)
- (7) Reconnect the negative battery cable.
- (8) Leave the hood open.
- (9) Start the engine.
- (10) With the engine running at 2500 rpm, turn the headlights and other lights on and off to adjust the generator load so that the value displayed on the ammeter is slightly above 30A.  
Limit value: Max. 0.3 V

**NOTE**

When the generator output is high and the value displayed on the ammeter does not decrease to 30A, set the value to 40A. Read the value displayed on the voltmeter at this time. In this case the limit value becomes max. 0.4V. Adjust the engine speed by gradually decreasing it until the value displayed on the ammeter

is 30A. Take a reading of the value displayed on the voltmeter at this time.

- (11) If the value displayed on the voltmeter is above the limit value, there is probably a malfunction in the generator output wire, so check the wiring between the generator "B" terminal and the battery (+) terminal (including fusible link). If a terminal is not sufficiently tight or if the harness has become discolored due to overheating, repair and then test again.
- (12) After the test, run the engine at idle.
- (13) Turn off all lights and turn the ignition switch to the OFF position.
- (14) Disconnect the negative battery cable.
- (15) Disconnect the ammeter, voltmeter and tachometer.
- (16) Connect the generator output wire to the generator "B" terminal.
- (17) Connect the negative battery cable.

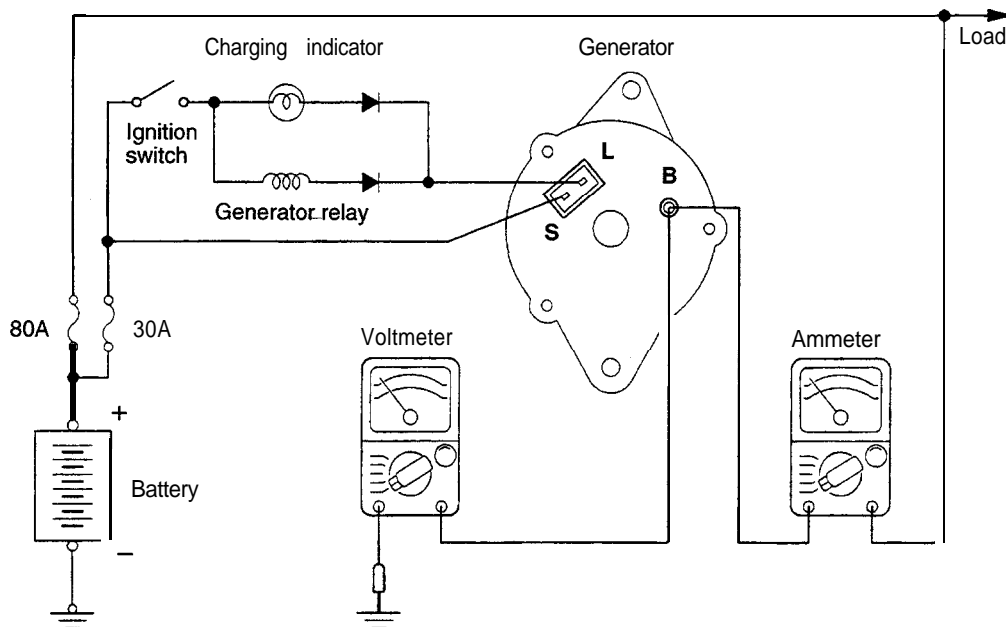
**OUTPUT CURRENT TEST**

6EN0893

This test determines whether the generator outputs normal current.

- (1) Before the test, always be sure to check the following.

- Generator installation
- Battery (Refer to GROUP 54 – Battery.)

**NOTE**

The battery to be used should be slightly discharged. The load in a fully-charged battery will be insufficient and the test may not be able to be carried out correctly.

- Generator drive belt tension (Refer to GROUP 11 – On-vehicle Service.)
- Fusible link
- Abnormal noise from the generator while the engine is running

- (2) Turn the ignition switch to the OFF position.  
 (3) Disconnect the negative battery cable.  
 (4) Disconnect the generator output wire from the generator “B” terminal and connect a DC test ammeter with a range of 0–100 A in series between the “B” terminal and the disconnected output wire. (Connect the (+) lead of the ammeter to the “B” terminal, and then connect the (–) lead of the ammeter to the disconnected output wire.)

**Caution**

**Never use clips but tighten bolts and nuts to connect the line. Otherwise loose connections (e.g. using clips) will lead to a serious accident because of high current.**

**NOTE**

A clamp-type ammeter which enables measurements to be taken without disconnecting the generator output wire is recommended.

- (5) Connect a voltmeter with a range of 0 – 20 V between the generator “B” terminal and the ground. (Connect the (+) lead of the voltmeter to the “B” terminal, and then connect the (–) lead of the voltmeter to the ground.)  
 (6) Connect a tachometer. (For the procedure for connecting the tachometer, refer to GROUP 11 – On-vehicle Service.)  
 (7) Connect the negative battery cable.  
 (8) Leave the hood open.  
 (9) Check to be sure that the reading on the voltmeter is equal to the battery voltage.

**NOTE**

If the voltage is 0 V, the cause is probably an open circuit in the wire or fusible link between the generator “B” terminal and the battery (+) terminal.

- (10) After turning the light switch on and turning on the headlights, start the engine.  
 (11) Immediately after setting the headlights to high beam and turning the heater blower switch to the high revolution position, increase the engine speed to 2,500 r/min and read the maximum current output value displayed on the ammeter.

**Limit value: 70% of nominal current output**

**NOTE**

- For the nominal current output, refer to the Generator Specifications.
  - Because the current from the battery will soon drop after the engine is started, the above step should be carried out as quickly as possible in order to obtain the maximum current output value.
  - The current output value will depend on the electrical load and the temperature of the generator body.
  - If the electrical load is small while testing, the specified level of current may not be output even though the generator is normal. In such cases, increase the electrical load by leaving the headlights turned on for some time to discharge the battery or by using the lighting system in another vehicle, and then test again.
  - The specified level of current also may not be output if the temperature of the generator body or the ambient temperature is too high. In such cases, cool the generator and then test again.
- (12) The reading on the ammeter should be above the limit value. If the reading is below the limit value and the generator output wire is normal, remove the generator from the engine and check the generator.  
 (13) Run the engine at idle speed after the test.  
 (14) Turn the ignition switch to the OFF position.  
 (15) Disconnect the negative battery cable.  
 (16) Disconnect the ammeter, voltmeter and tachometer.  
 (17) Connect the generator output wire to the generator “B” terminal.  
 (18) Connect the negative battery cable.

**REGULATED VOLTAGE TEST**

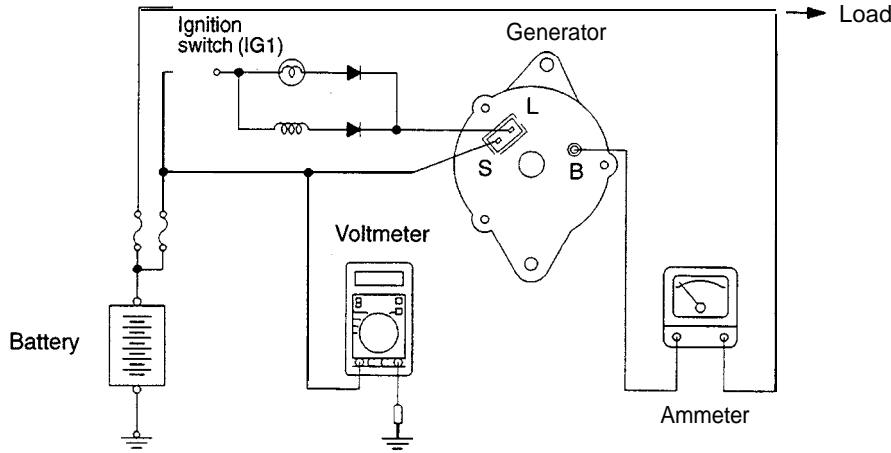

6EN1029

This test determines whether the voltage regulator is correctly controlling the generator output voltage.

- (1) Always be sure to check the following before the test.
  - Generator installation
  - Check to be sure that the battery installed in the vehicle is fully charged. (Refer to GROUP 54 – Battery.)
  - Generator drive belt tension (Refer to GROUP 00 – Maintenance Service.)
  - Fusible link
  - Abnormal noise from the generator while the engine is running
- (2) Turn the ignition switch to the OFF position.
- (3) Disconnect the negative battery cable.
- (4) Connect a digital-type voltmeter between the generator “S” terminal and the ground. (Connect the (+) lead of the voltmeter to the “S” terminal, and then connect the (–) lead of the voltmeter to a secure ground or to the battery (–) terminal.)
- (5) Disconnect the generator output wire from the generator “B” terminal.
- (6) Connect a DC test ammeter with a range of 0–100A in series between the “B” terminal and the disconnected output wire. (Connect the (+) lead of the ammeter to the “B” terminal, and then connect the (–) lead of the ammeter to the disconnected output wire.)
- (7) Connect a tachometer. (Refer to GROUP 11 – On-vehicle Service.)
- (8) Reconnect the negative battery cable.

- (9) Turn the ignition switch to the ON position and check that the reading on the voltmeter is equal to the battery voltage.

**NOTE**

If the voltage is 0 V, the cause is probably an open circuit in the wire or fusible link between the generator “S” terminal and the battery (+) terminal.

- (10) Check to be sure that all lights and accessories are off.
- (11) Start the engine.
- (12) Increase the engine speed to 2,500 r/min.
- (13) Read the value displayed on the voltmeter when the current output by the generator becomes 10A or less.
- (14) If the voltage reading conforms to the value in the voltage regulation table, then the voltage regulator is operating normally. If the voltage is outside the standard value, there is a malfunction of the voltage regulator or of the generator.
- (15) After the test, lower the engine speed to the idle speed.
- (16) Turn the ignition switch to the “OFF” position.
- (17) Disconnect the negative battery cable.
- (18) Disconnect the ammeter, voltmeter and tachometer.
- (19) Connect the generator output wire to the generator “B” terminal.
- (20) Connect the negative battery cable.

**VOLTAGE REGULATION TABLE**

Inspection terminal	Voltage regulator ambient temperature (°C [°F])	Standard value (V)	Inspection terminal	Voltage regulator ambient temperature (°C [°F])	Standard value (V)
Terminal “S”	-20 (-4)	14.2-15.4	Terminal “S”	60 (140)	13.4-14.5
	20 (68)	13.9-14.9		80 (176)	13.1–14.5

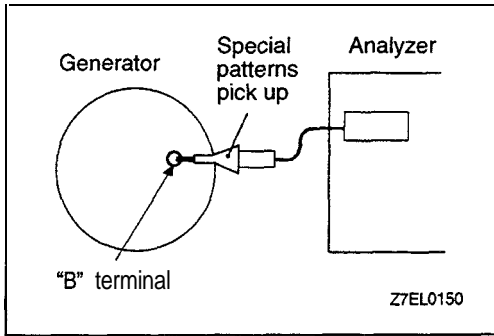

**WAVE-FORM CHECK USING AN ANALYZER MEASUREMENT METHOD**

Connect the analyzer special patterns pick-up to the generator B terminal.

**STANDARD WAVE-FORM Observation Conditions**

FUNCTION	SPECIAL PATTERNS
PATTERN HEIGHT	VARIABLE
VARIABLE Knob	Adjust while viewing the wave-form
PATTERN SELECTOR	RASTER
Engine speed	Curb idle speed

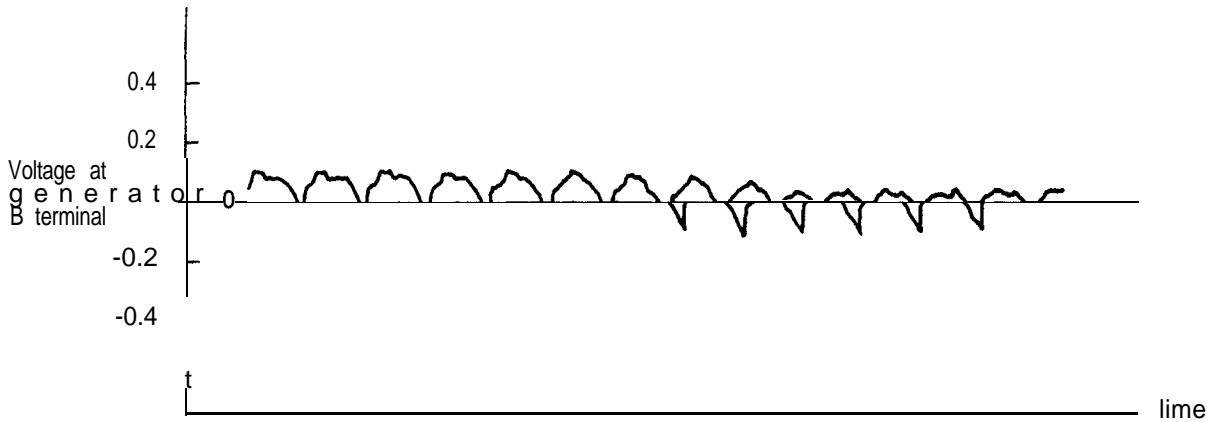

Z7EL0115

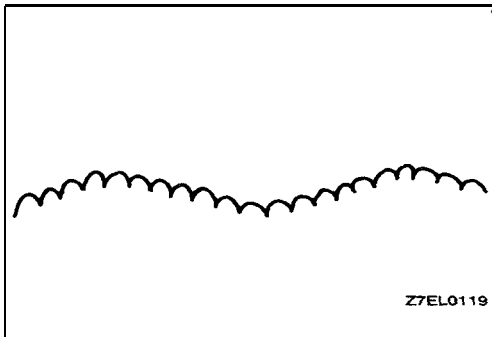





**NOTE**

Furthermore, the voltage wave-form of the generator B terminal can undulate as shown at left. This wave-form is produced when the regulator operates according to fluctuations in the generator load (current), and is normal for the generator.

**ABNORMAL WAVE-FORMS EXAMPLES**

**NOTE**

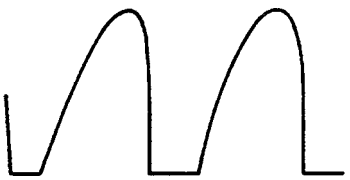
1. The size of the wave-form patterns differs largely depending on the adjustment of the variable knob on the analyzer.
2. Identification of abnormal wave-forms is easier when there is a large output current (regulator is not operating). (Wave-forms can be observed when the headlights are illuminated.)
3. Check the conditions of the charge light (illuminated/not illuminated) also, and carry out a total check.

Abnormal wave-forms	Problem cause
<p>Example 1</p>  <p style="text-align: right;">Z7EL0120</p>	<ul style="list-style-type: none"> <li>● Open diode</li> </ul>
<p>Example 2</p>  <p style="text-align: right;">Z7EL0121</p>	<ul style="list-style-type: none"> <li>● Short in diode</li> </ul>
<p>Example 3</p>  <p style="text-align: right;">Z7EL0122</p>	<ul style="list-style-type: none"> <li>● Broken wire in statorcoil</li> </ul>
<p>Example 4</p>  <p style="text-align: right;">Z7EL0123</p>	<ul style="list-style-type: none"> <li>● Short in stator coil</li> </ul>
<p>Example 5</p>  <p style="text-align: right;">Z7EL0124</p> <p>At this time, the charge light is illuminated.</p>	<ul style="list-style-type: none"> <li>● Open supplementary diode</li> </ul>

## GENERATOR

## REMOVAL AND INSTALLATION

**Pre-removal and Post-installation Operation**

- Removal and Installation of Right Bank Warm Up Three-Way Catalytic Converter  
(Refer to GROUP 15–Exhaust Pipe, Main Muffler and Catalytic Converter.)

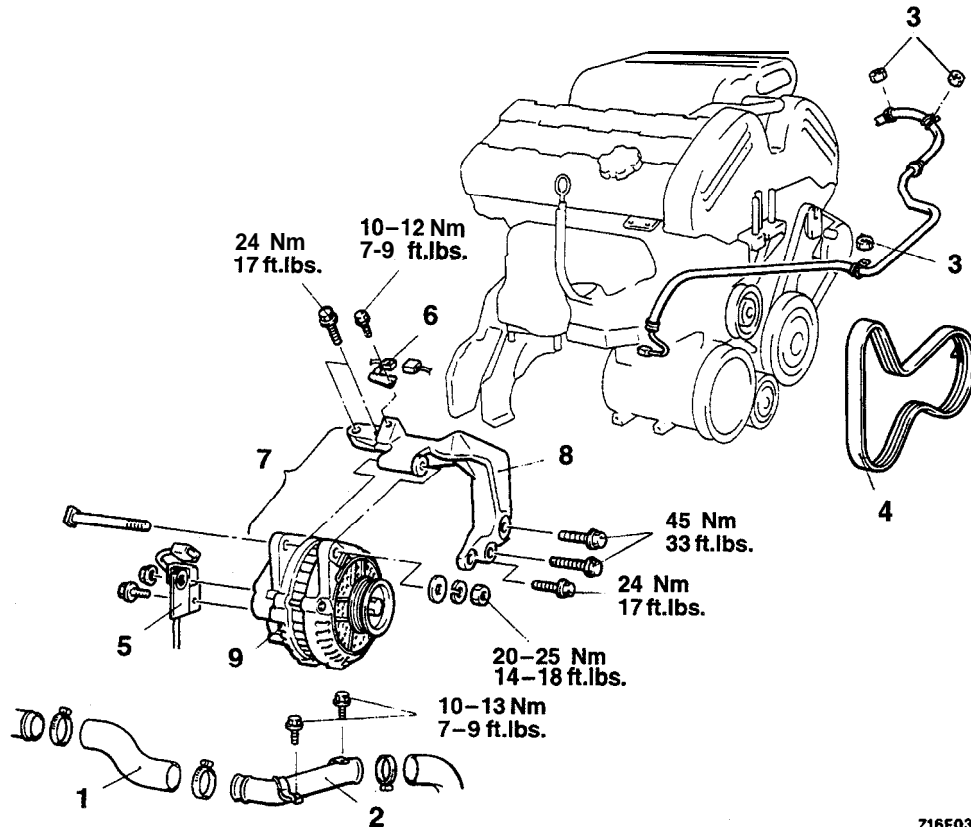

Z16F0346

**Removal steps**

1. Air hose E <Turbo>
2. Air hose C <Turbo>
3. Suction hose clamp nuts  
<Vehicles with air conditioning>
4. Drive belt  
(Refer to GROUP 11 –  
Engine Adjustment.)

5. Generator connector
6. Heated oxygen sensor connector
7. Generator and generator bracket assembly
8. Generator bracket
9. Generator

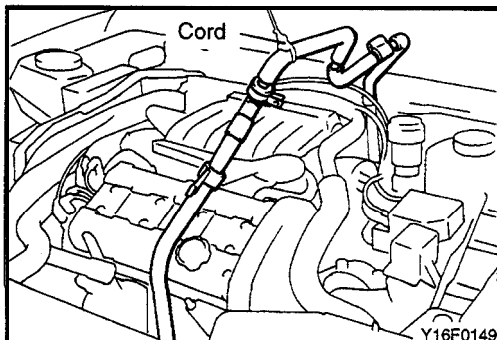
**REMOVAL SERVICE POINT****◀▶ CLAMP NUT REMOVAL**

On vehicles with an air conditioning, remove the clamp nut, raise the suction hose and suspend it from the engine hood using a cord.

**DISASSEMBLY AND REASSEMBLY**  
(Up to 1995 models)

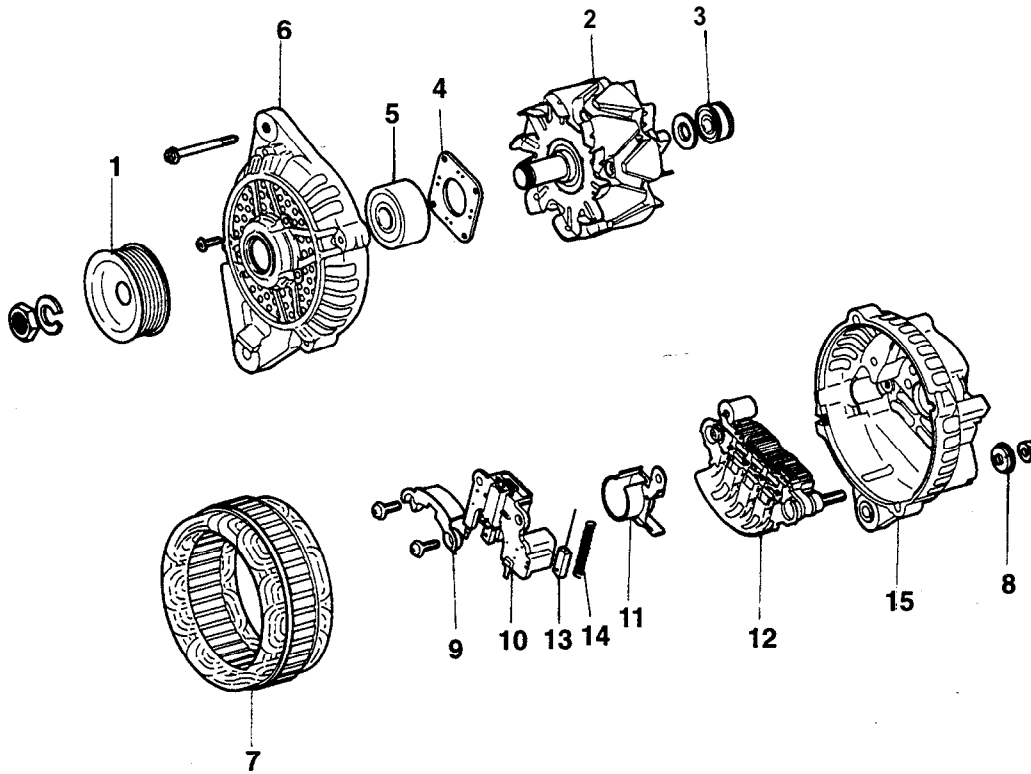

**Disassembly steps**

◀A▶

▶A◀

1. Generator pulley
2. Rotor assembly
3. Rear bearing
4. Bearing retainer
5. Front bearing
6. Front bracket
7. Stator

◀B▶

8. Insulator
9. Plate
10. Regulator and brush holder
11. Slinger
12. Rectifier
13. Brush
14. Brush spring
15. Rear bracket

Z7EL0104



(From 1996 models)

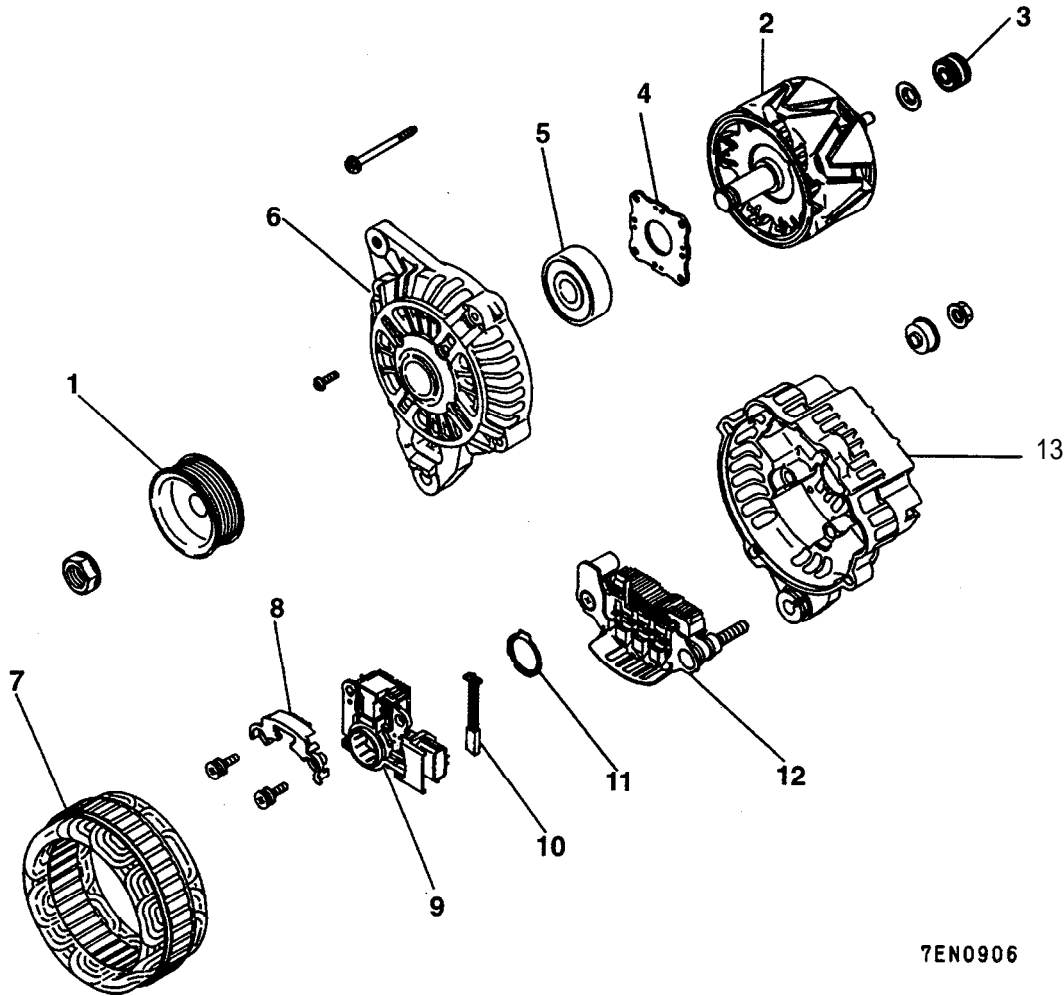

7EN0906

**Disassembly steps**

- ◀A▶ 1. Pulley
- ▶A▶ 2. Rotor assembly
- 3. Rear bearing
- 4. Bearing retainer
- 5. Front bearing
- 6. Front bracket
- ◀B▶ 7. Stator assembly

- ◀B▶ 8. Plate
- 9. Regulator and brush holder
- 10. Brush
- 11. Slinger
- 12. Rectifier assembly
- 13. Rear bracket

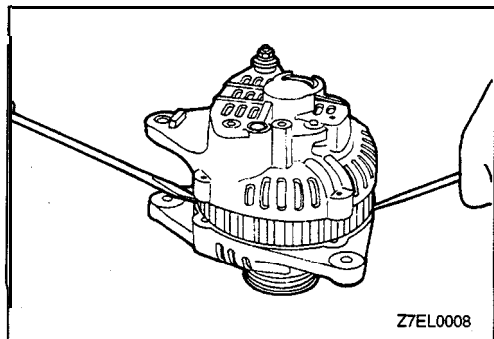

Z7EL0008

**DISASSEMBLY SERVICE POINT**

◀A▶ **GENERATOR PULLEY REMOVAL**

- (1) Remove the bolts.
- (2) Insert plain screwdriver between front bracket and stator core and pry downward.

**Caution**

Do not insert screwdriver too deep, as there is danger of damage to stator coil.

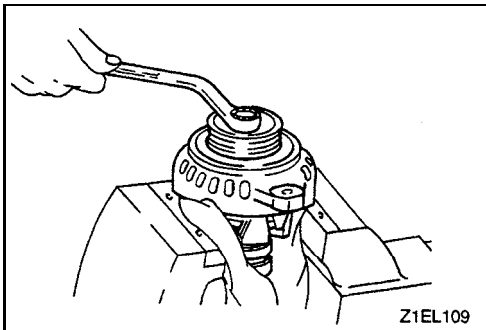

- (3) Clamp the rotor in a vise with soft jaws.
- (4) After removing the nut, remove the pulley and front bracket from the rotor.

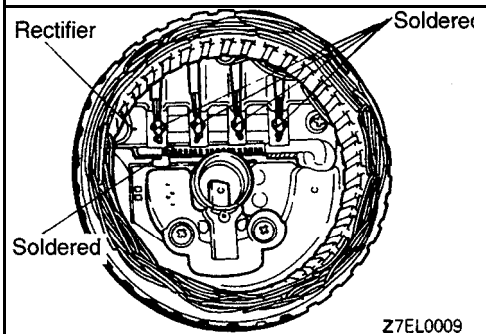

### ◀B▶ STATOR / REGULATOR AND BRUSH HOLDER REMOVAL

- (1) When removing the stator, unsolder stator lead wire from the main diode of the rectifier.
- (2) When removing the brush holder, unsolder it from the rectifier.

#### Caution

- (1) When soldering or unsoldering, be careful to make sure that heat of soldering iron is not transmitted to diodes for a long period. Finish soldering or unsoldering in as short a time as possible.
- (2) Be careful that no undue force is exerted to leads of diodes.

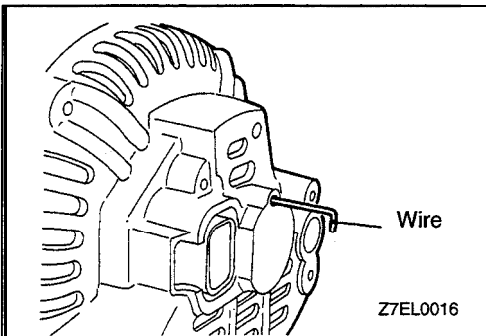

### REASSEMBLY SERVICE POINT

#### ▶A▶ ROTOR ASSEMBLY INSTALLATION

Before rotor is attached to rear bracket, insert wire through small hole made in rear bracket to lift brush. After rotor has been installed, remove the wire.

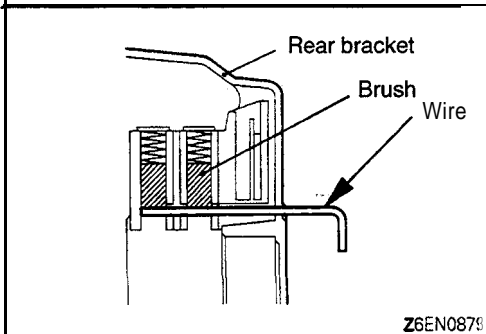

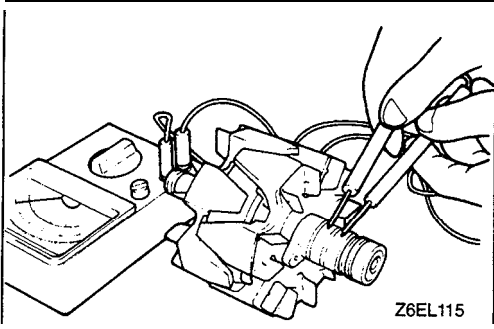
**INSPECTION****ROTOR**

- (1) Check field coil for continuity. Check to ensure that there is continuity between slip rings. If resistance is extremely small, it means that there is a short. If there is no continuity or if there is short circuit, replace rotor assembly.

**Resistance value : Approx. 3–5 Ω**

- (2) Check field coil for grounding. Check to ensure that there is no continuity between slip ring and core. If there is continuity, replace rotor assembly.

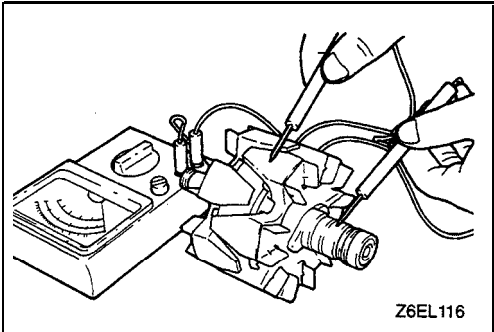
**STATOR**

- (1) Make continuity test on stator coil. Check to ensure that there is continuity between coil leads. If there is no continuity, replace stator assembly.

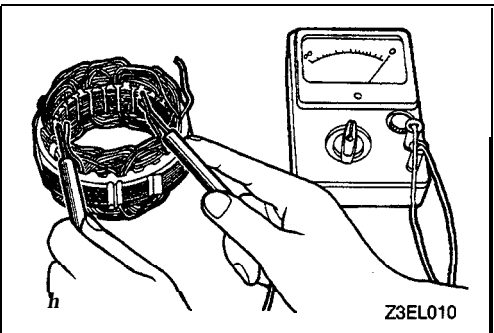

- (2) Check coil for grounding. Check to ensure that there is no continuity between coil and core. If there is continuity, replace stator assembly.

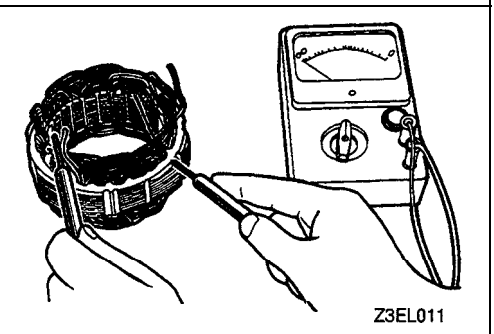
**RECTIFIERS****(1) Positive Rectifier Test**

Check for continuity between positive rectifier and stator coil lead connection terminal with a circuit tester. If there is continuity in both directions, diode is shorted. Replace rectifier assembly.

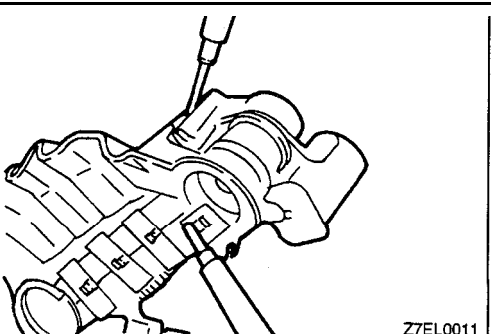

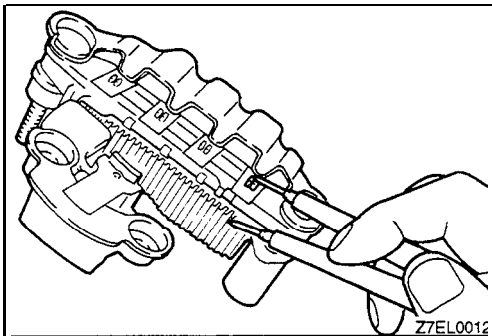
**(2) Negative Rectifier Test**

Check for continuity between negative rectifier and stator coil lead connection terminal. If there is continuity in both directions, diode is shorted, and rectifier assembly must be replaced.

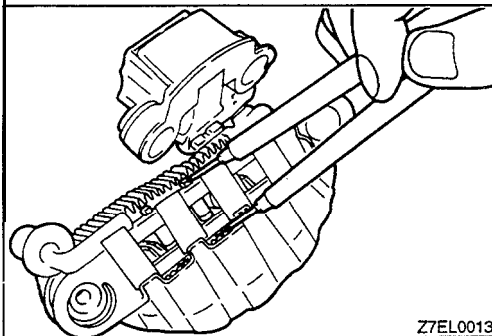
**(3) Diode Trio Test**

Check three diodes for continuity by connecting an ammeter to both ends of each diode. If there is no continuity in both directions, diode is faulty and heatsink assembly must be replaced.

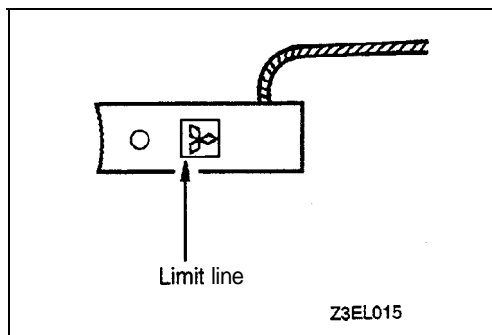
**BRUSH REPLACEMENT <Up to 1995 models>**

- (1) Replace brush by the following procedures if it has been worn to limit line.

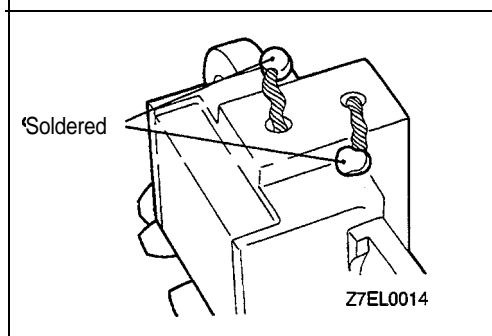

- (2) Unsolder pigtail and remove old brush and spring.

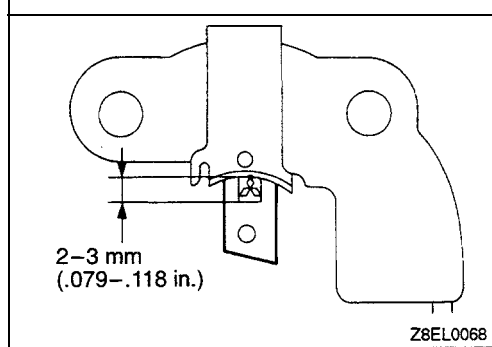

- (3) Install brush spring and new brush in brush holder.
- (4) Insert the brush to where there is a space 2 to 3 mm (.079 to .118 in.) between the limit line and the end of the brush holder.

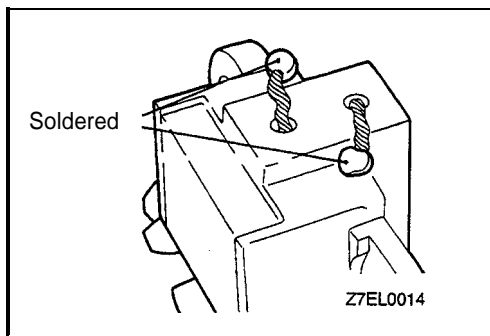

- (5) Solder pigtail to brush holder as shown in the illustration.

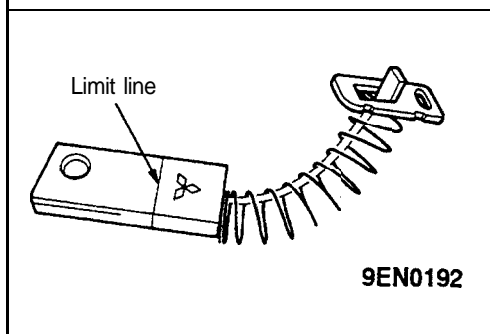

### BRUSH REPLACEMENT <From 1996 models>

- (1) Replace brush by the following procedures if it has been worn to limit line.

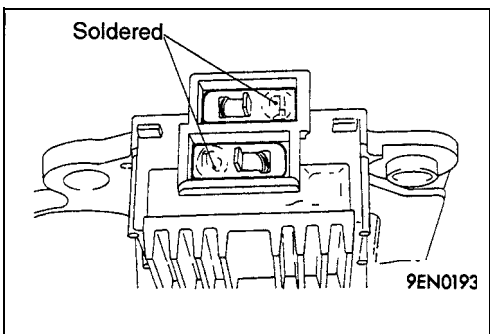

- (2) Unsolder pigtail and remove old brush and spring.

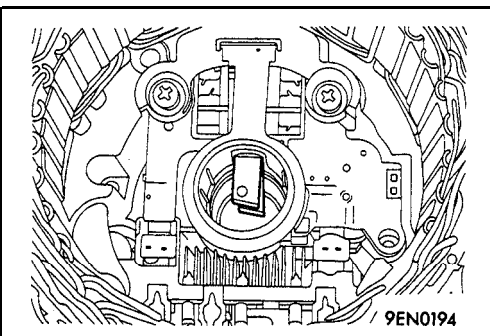

- (3) When installing a new brush, push the brush in the brush holder as shown in the illustration, and solder the lead wire.

**STARTING SYSTEM****SPECIFICATIONS****GENERAL SPECIFICATIONS****STARTER MOTOR**

Items	Specifications
Type	Reduction drive (with planetary gear)
Rated output kW/V	1.2/12
No. of pinion teeth	8

**SERVICE SPECIFICATIONS****STARTER MOTOR**

Items	Standard value	Limit
Free running characteristics	Terminal voltage V	11
	Current A	90 or less
	Speed r/min	3,000 or more
Pinion gap mm (in.)	0.5–2.0 (.020–.079)	
Commutator runout mm (in.)	0.05 (.0020)	0.1 (.004)
Commutator diameter mm (in.)	29.4 (1.158)	28.4 (1.118)
Undercut depth mm (in.)	0.5 (.020)	

**TROUBLESHOOTING**

**CIRCUIT DIAGRAM**

<VEHICLES WITHOUT THEFT-ALARM SYSTEM>

<M/T>

<A/T>

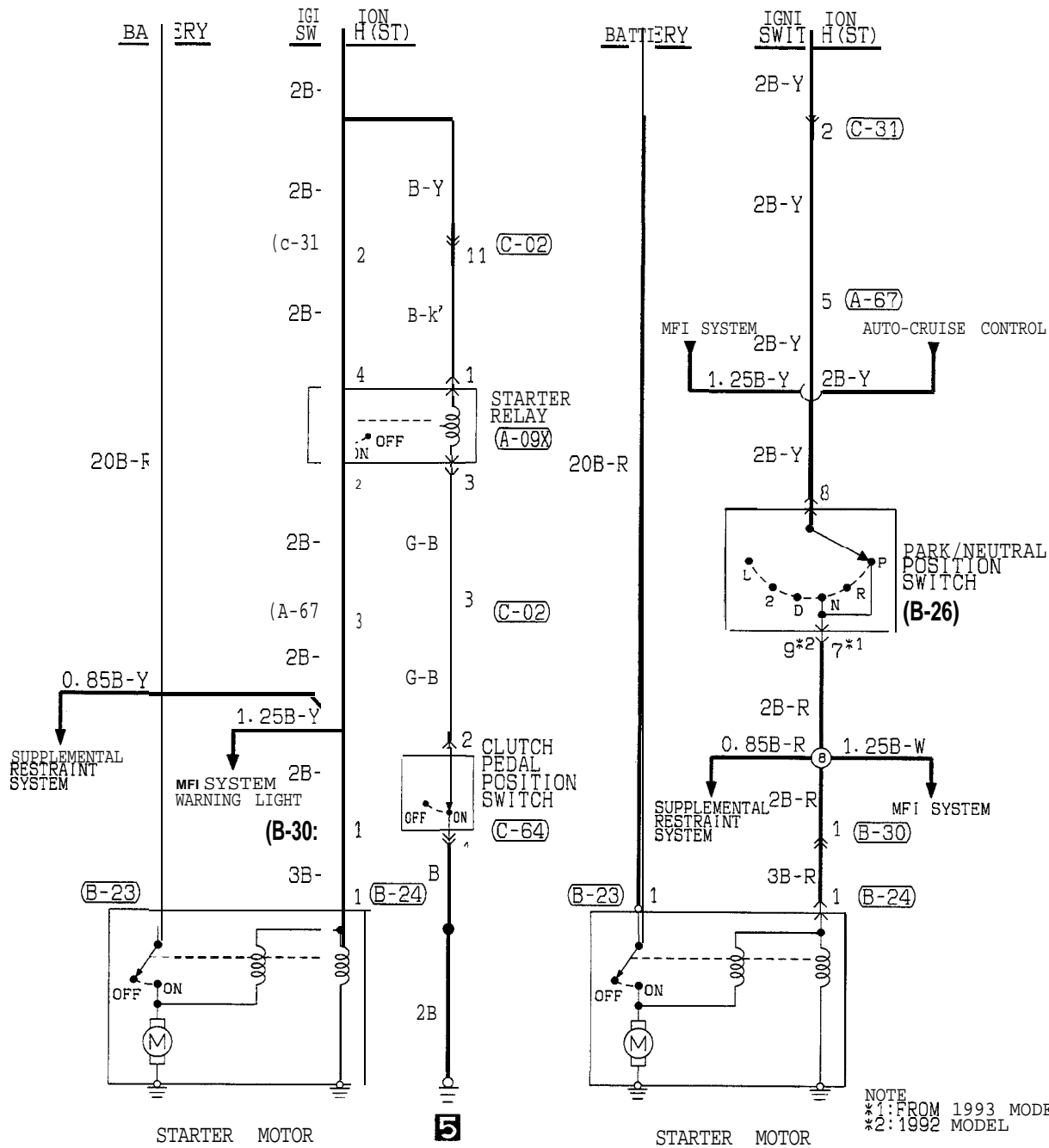

NOTE  
\*1: FROM 1993 MODEL  
\*2: 1992 MODEL

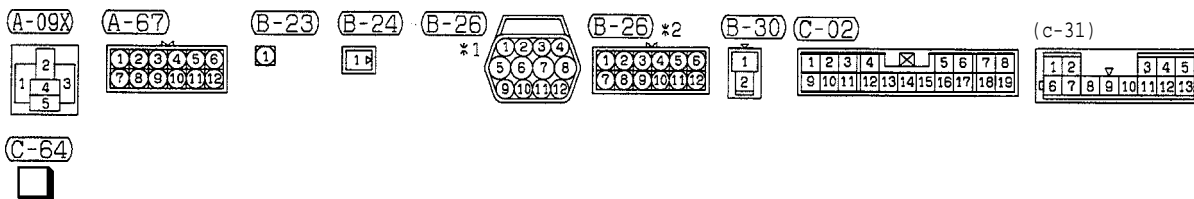

<VEHICLES WITH THEFT-ALARM SYSTEM (M/T)>

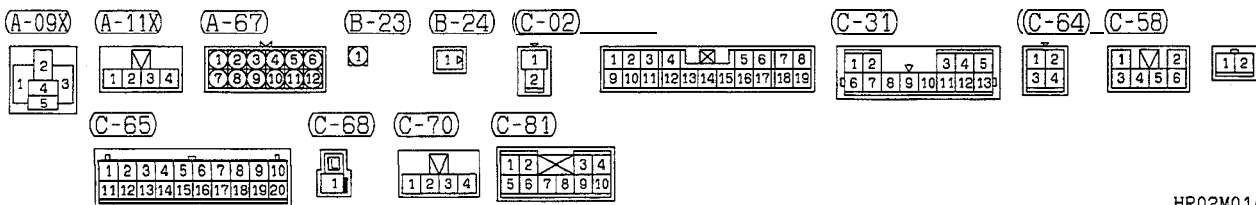
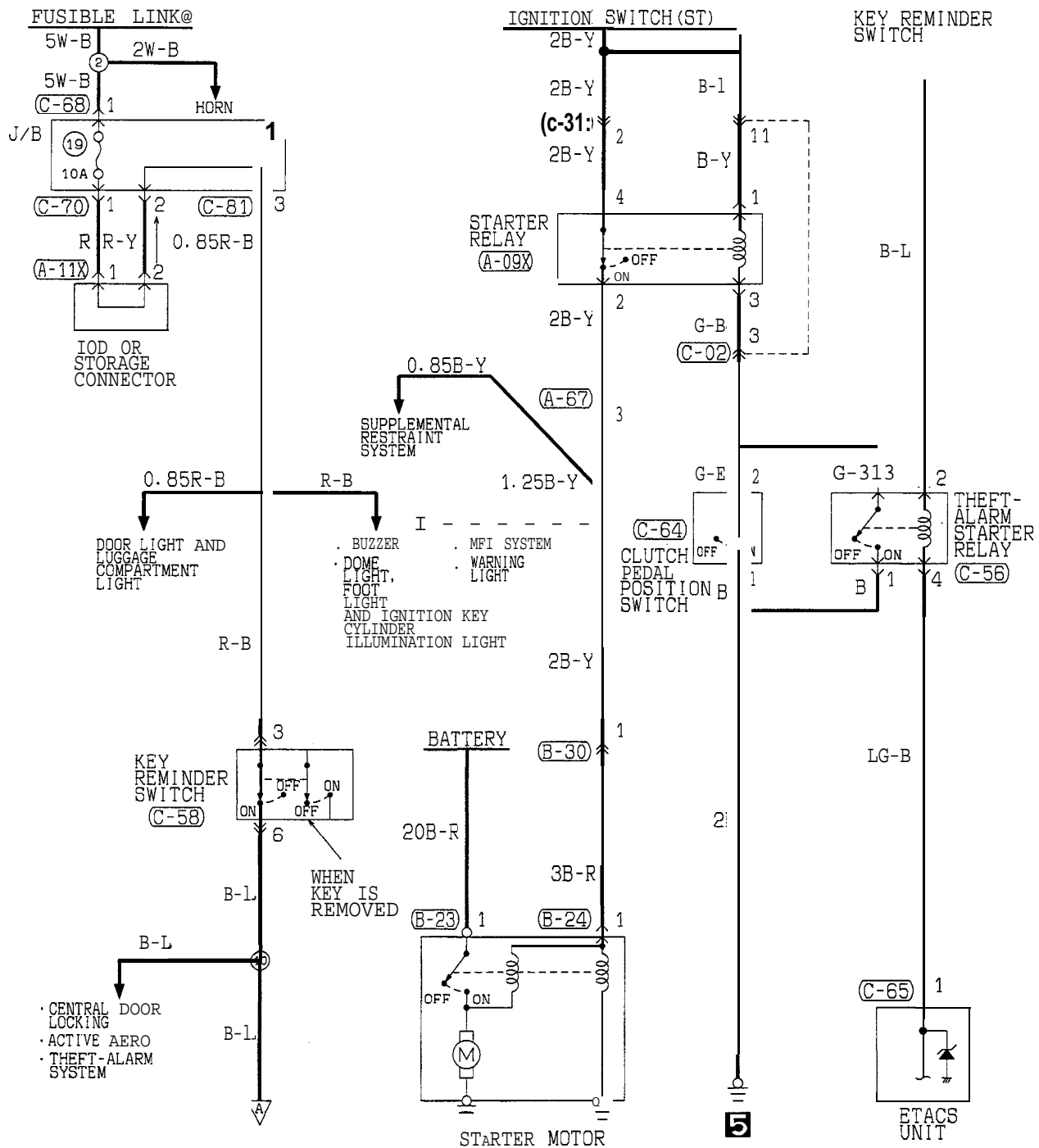

TSB Revision



<VEHICLES WITH THEFT-ALARM SYSTEM (AK)>

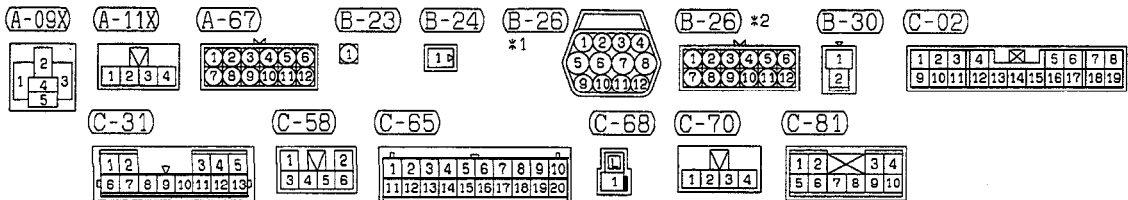
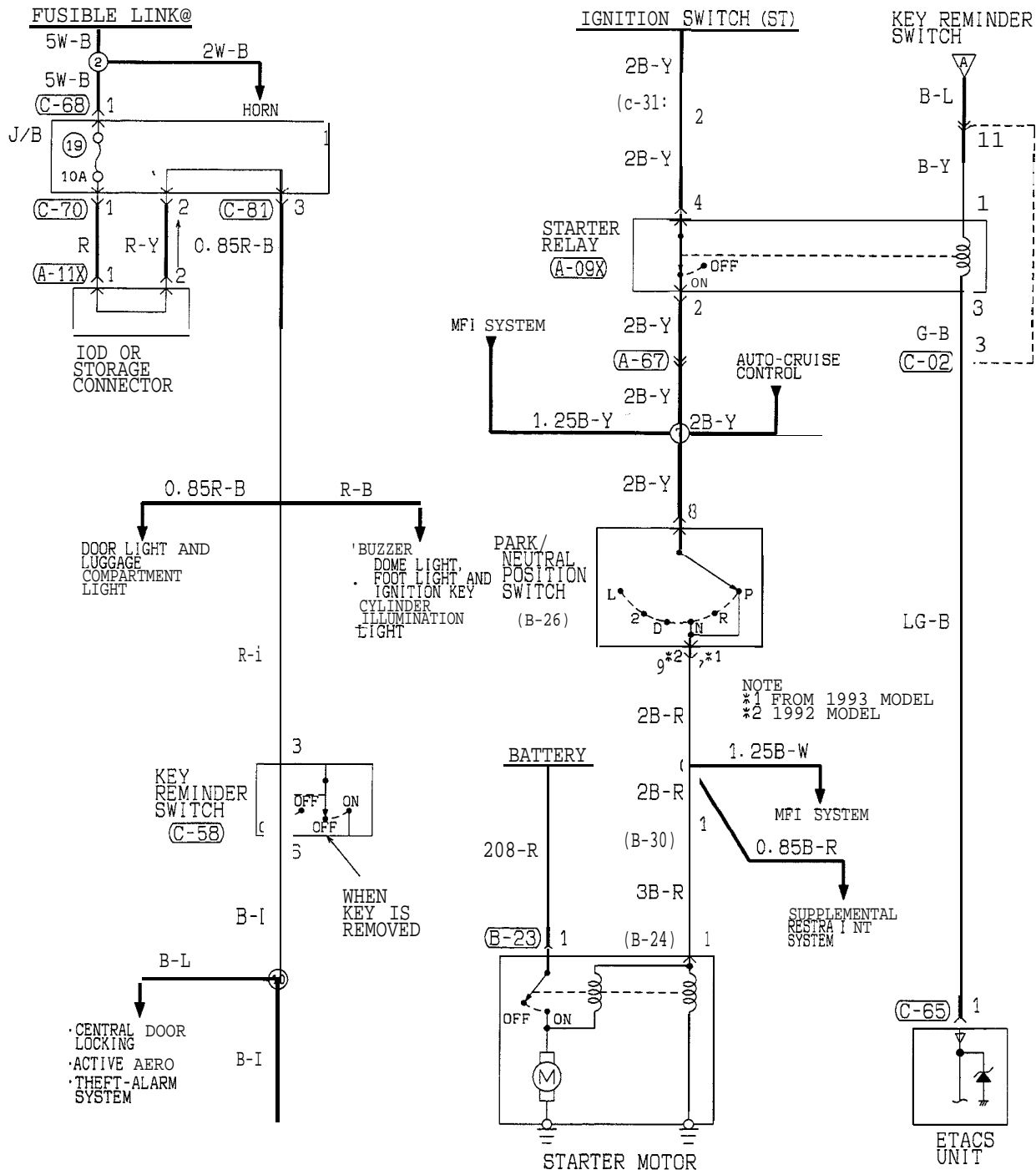

**OPERATION**

- For models equipped with the M/T, the clutch pedal position switch contact is switched OFF when the clutch pedal is depressed; when the ignition switch is then switched to the “ST” position, electricity flows to the starter relay and the starter motor, the contact (magnetic switch) of the starter is switched ON and the starter motor is activated.

**NOTE**

If the ignition switch is switched to the “ST” position without the clutch pedal being depressed, electricity flows to the starter relay (coil), the clutch pedal position switch (contacts) and to ground, with the result that the contacts of the starter relay are switched OFF, and, because the power to the starter motor is thereby interrupted, the starter motor is not activated.

- For models equipped with the A/T, when the ignition switch is switched to the “ST” position while the selector lever is at the “P” or “N” position, the contact (magnetic switch) of the starter is switched ON and the starter motor is activated.

**TROUBLESHOOTING HINTS**

The starter motor does not operate at all.

- Check the starter (coil).
- Check for poor contact at the battery terminals and starter.
- Check Park/Neutral position switch.
- Check clutch pedal position switch.
- Check starter relay.
- Check theft-alarm starter relay.
- Check key reminder switch.

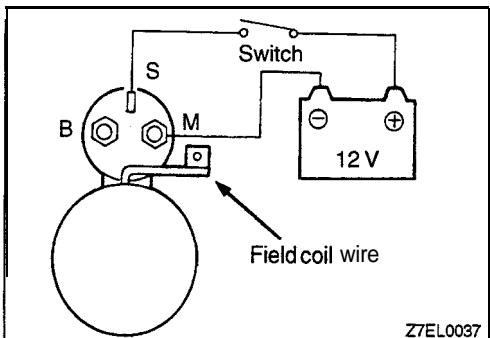
**STARTER MOTOR****REMOVAL AND INSTALLATION**

Refer to GROUP 22 – Manual Transaxle, or GROUP 23 – Automatic Transaxle.

**INSPECTION****PINION GAP ADJUSTMENT**

- Disconnect field coil wire from M-terminal of magnetic switch.
- Connect a 12 V battery between S-terminal and M-terminal.
- Set switch to “ON”, and pinion will move out.

**Caution**

**This test must be performed quickly (in less than 10 seconds) to prevent coil from burning.**

- Check pinion to stopper clearance (pinion gap) with a feeler gauge.

**Standard value: 0.5-2.0 mm (.020-.079 in.)**

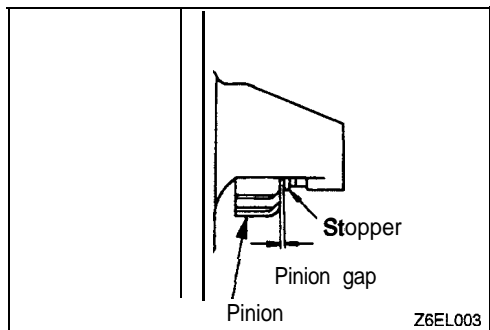

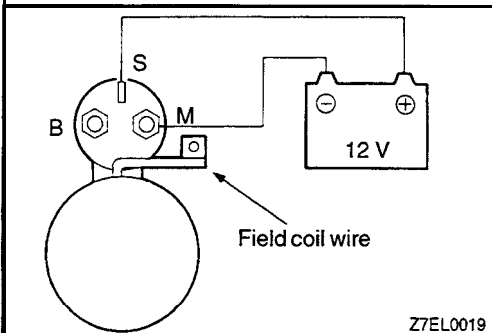
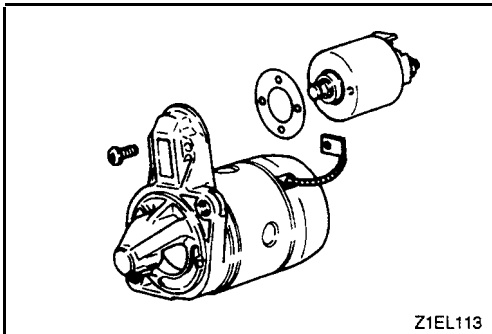

- (5) If pinion gap is out of specification, adjust by adding or removing gaskets between magnetic switch and front bracket.

### MAGNETIC SWITCH PULL-IN TEST

- (1) Disconnect field coil wire from M-terminal of magnetic switch.
- (2) Connect a 12 V battery between S-terminal and M-terminal.

#### Caution

**This test must be performed quickly (in less than 10 seconds) to prevent coil from burning.**

- (3) If pinion moves out, then pull-in coil is good. If it doesn't, replace magnetic switch.

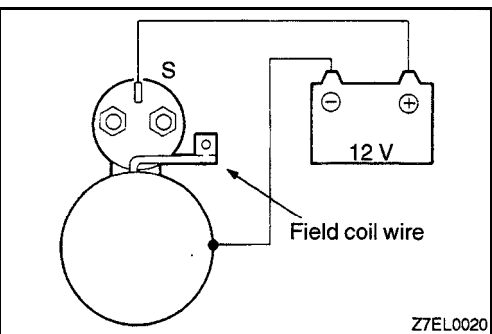

### MAGNETIC SWITCH HOLD-IN TEST

- (1) Disconnect field coil wire from M-terminal of magnetic switch.
- (2) Connect a 12 V battery between S-terminal and body.

#### Caution

**This test must be performed quickly (in less than 10 seconds) to prevent coil from burning.**

- (3) Pull out the pinion by hand until it comes into contact with the pinion stopper.
- (4) If pinion remains out, everything is in order. If pinion moves in, hold-in circuit is open. Replace magnetic switch.

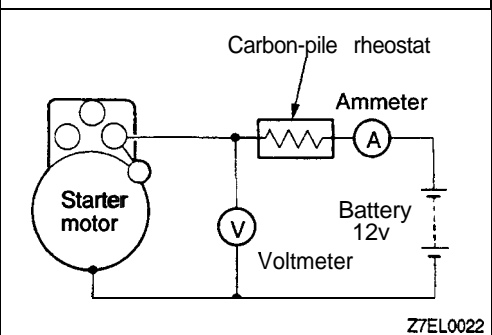

### FREE RUNNING TEST

- (1) Place starter motor in a vise equipped with soft jaws and connect a fully-charged 12-volt battery to starter motor as follows:
- (2) Connect a test ammeter (100-ampere scale) and carbon pile rheostat in series with battery positive post and starter motor terminal.
- (3) Connect a voltmeter (15-volt scale) across starter motor.
- (4) Rotate carbon pile to full-resistance position.
- (5) Connect battery cable from battery negative post to starter motor body.
- (6) Adjust rheostat until the battery voltage shown by the voltmeter is 11 V.
- (7) Confirm that the maximum amperage is within the specifications and that the starter motor turns smoothly and freely.

**Current: Max. 90 Amps**

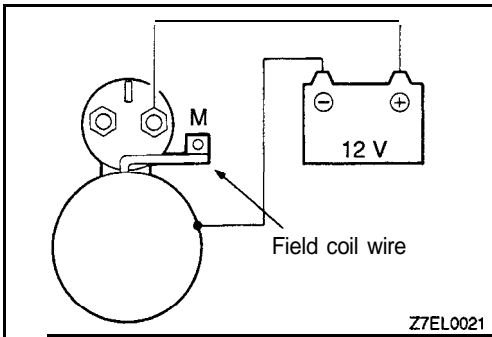

**MAGNETIC SWITCH RETURN TEST**

- (1) Disconnect field coil wire from M-terminal of magnetic switch.
- (2) Connect a 12 V battery between M-terminal and body.

**Caution**

**This test must be performed quickly (in less than 10 seconds) to prevent coil from burning.**

- (3) Pull pinion out and release. If pinion quickly returns to its original position, everything is in order. If it doesn't, replace magnetic switch.

**Caution**

**When pulling out the pinion, be careful not to have your finger pinched.**

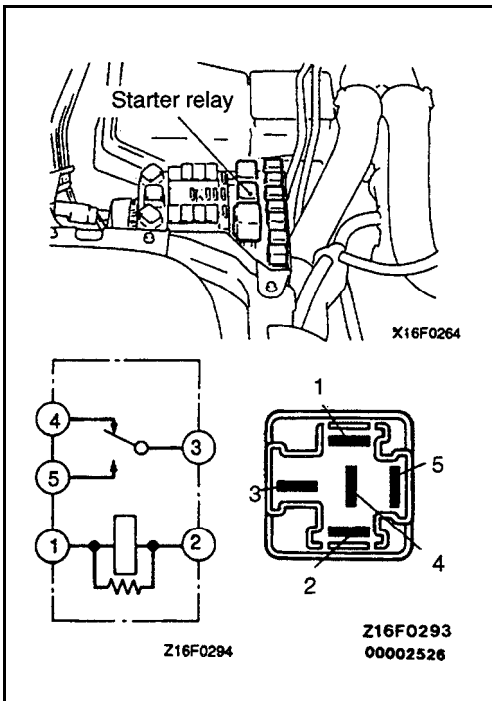

**STARTER RELAY**

- (1) Remove the starter relay from the relay box.
- (2) Connect battery to terminal 2 and check continuity between terminals with terminal 4 grounded.

Power is supplied	3-4 terminals	No continuity
	3-5 terminals	Continuity
Power is not supplied	3-4 terminals	Continuity
	3-5 terminals	No continuity
	1-2 terminals	Continuity

DISASSEMBLY AND REASSEMBLY

<EXCEPT FROM 1994 CALIFORNIA VERSION>

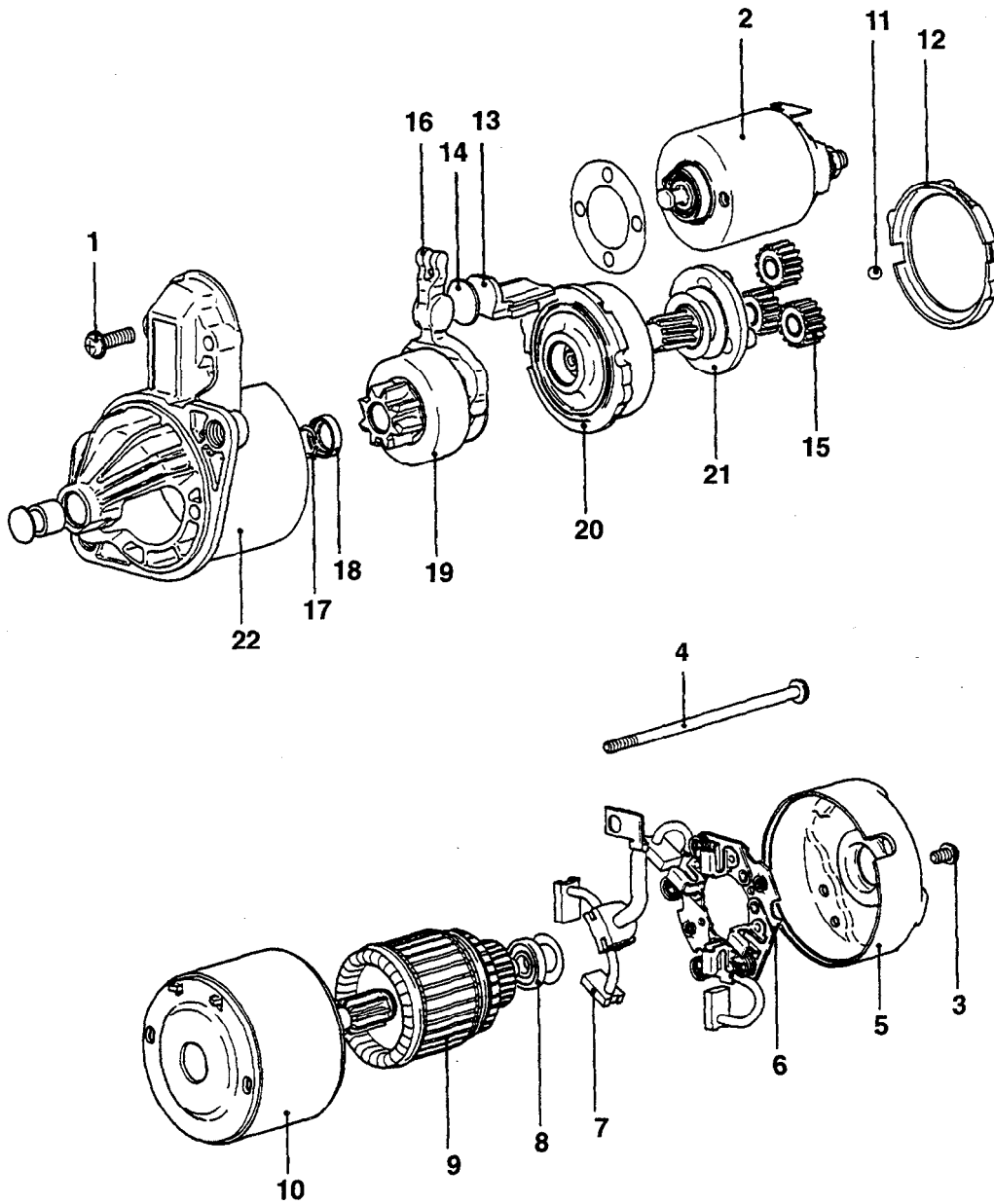

Z6EL199

Disassembly steps

- 1. Screw
- 2. Magnetic switch
- 3. Screw
- 4. Screw
- 5. Rear bracket
- 6. Brush holder
- 7. Brush
- 8. Rear bearing
- 9. Armature
- 10. Yoke assembly
- 11. Ball

- 12. Packing A
- 13. Packing B
- 14. Plate
- 15. Planetary gear
- 16. Lever
- 17. Snap ring
- 18. Stop ring
- 19. Overrunning clutch
- 20. Internal gear
- 21. Planetary gear holder
- 22. Front bracket



<FROM 1994 CALIFORNIA VERSION>

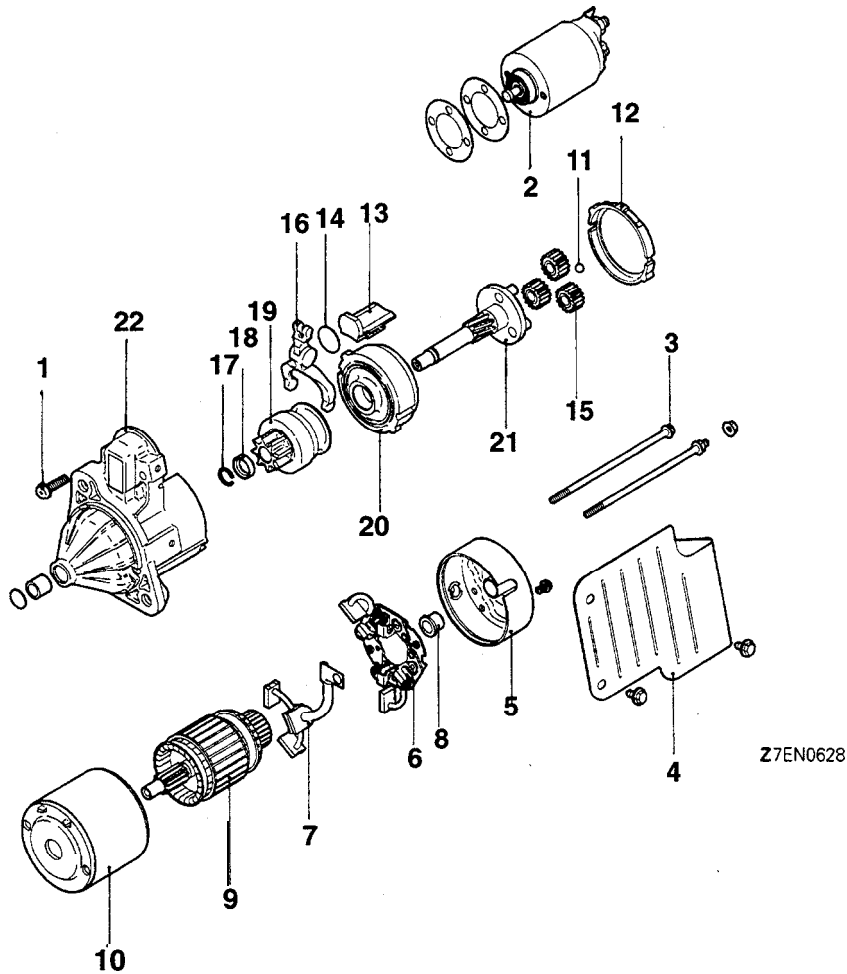

Z7EN0628

**Disassembly steps**

- |   |   |
|---|---|
| <ul style="list-style-type: none"> <li>1. Screw</li> <li>2. Magnetic switch</li> <li>3. Screw</li> <li>4. Starter cover</li> <li>5. Rear bracket</li> <li>6. Brush holder</li> <li>7. Brush</li> <li>8. Bush</li> <li>9. Armature</li> <li>10. Yoke assembly</li> <li>11. Ball</li> </ul> | <ul style="list-style-type: none"> <li>12. Packing A</li> <li>13. Packing B</li> <li>14. Plate</li> <li>15. Planetary gear</li> <li>16. Lever</li> <li>17. Snap ring</li> <li>18. Stop ring</li> <li>19. Overrunning clutch</li> <li>20. Internal gear</li> <li>21. Planetary gear holder</li> <li>22. Front bracket</li> </ul> |
|---|---|



**DISASSEMBLY SERVICE POINTS**

**◀A▶ ARMATURE / BALL REMOVAL**

**Caution**

When removing the armature, be careful not to lose the ball (which is used as a bearing) in the armature end.

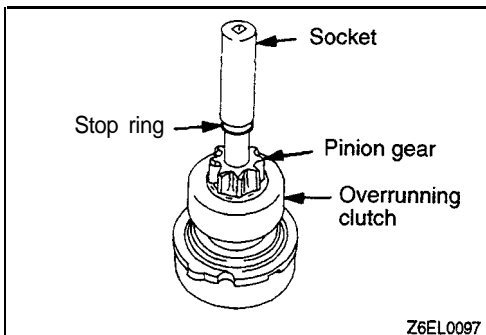

### ◀B▶ SNAP RING / STOP RING REMOVAL

(1) Press the stop ring, by using an appropriate socket, wrench, to the snap ring side.

(2) After removing the snap ring (by using snap-ring pliers), remove the stop ring and the overrunning clutch.

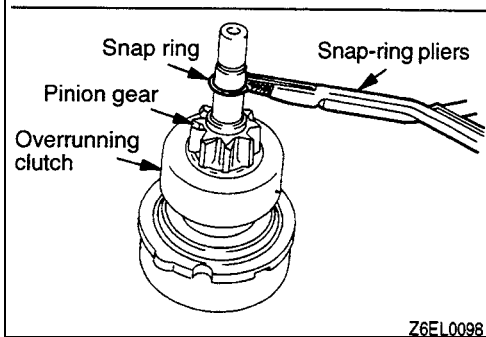

### STARTER MOTOR PARTS CLEANING

1. Do not immerse parts in cleaning solvent. Immersing the yoke and field coil assembly and/or armature will damage insulation. Wipe these parts with a cloth only.
2. Do not immerse drive unit in cleaning solvent. Overrunning clutch is pre-lubricated at the factory and solvent will wash lubrication from clutch.
3. The drive unit may be cleaned with a brush moistened with cleaning solvent and wiped dry with a cloth.

### REASSEMBLY SERVICE POINT

#### ▶A◀ STOP RING / SNAP RING INSTALLATION

Using a suitable pulling tool, pull overrunning clutch stop ring over snap ring.

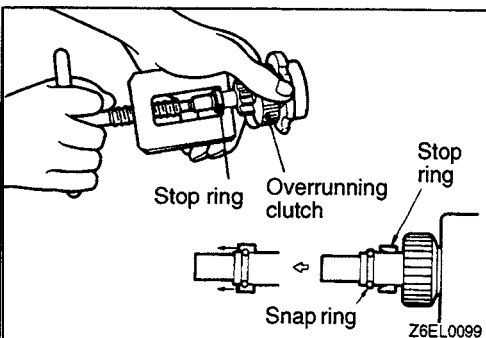

### INSPECTION

#### COMMUTATOR INSPECTION

(1) Place the armature on a pair of V-blocks, and check the deflection by using a dial gauge.

**Standard value: 0.05 mm (.0020 in.)**

**Limit: 0.1 mm (.004 in.)**

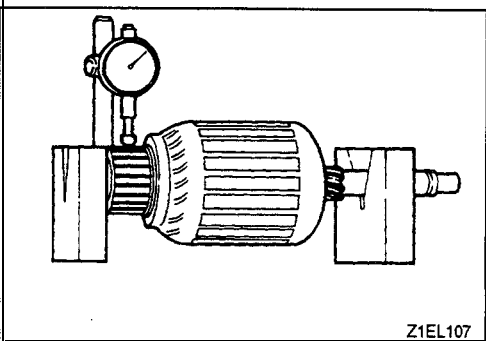

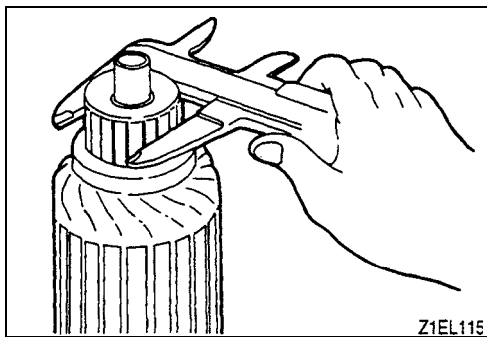

- (2) Check the outer diameter of the commutator.

**Standard value: 29.4 mm (1.158 in.)**

**Limit: 28.4 mm (1.118 in.)**

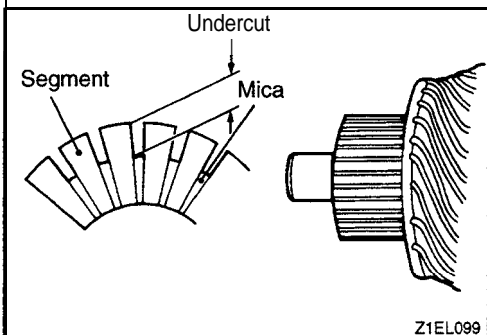

- (3) Check the depth of the undercut between segments.

**Standard value: 0.5 mm (.020 in.)**

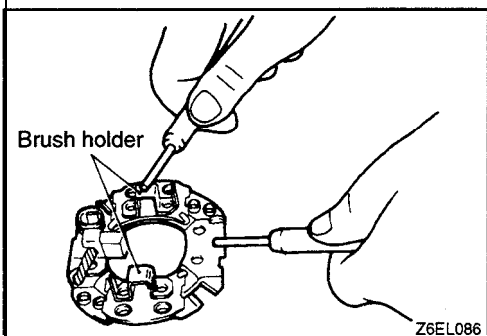

#### BRUSH HOLDER

Check for continuity between brush holder plate and brush holder.

The normal condition is non-continuity.

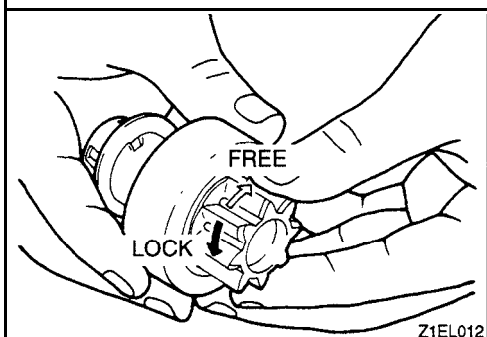

#### OVERRUNNING CLUTCH

1. While holding clutch housing, rotate the pinion. Drive pinion should rotate smoothly in one direction, but should not rotate in opposite direction. If clutch does not function properly, replace overrunning clutch assembly.
2. Inspect pinion for wear or burrs. If pinion is worn or burred, replace overrunning clutch assembly. If pinion is damaged, also inspect ring gear for wear or burrs.

#### FRONT AND REAR BRACKET BUSHING

Inspect bushing for wear or burrs. If bushing is worn or burred, replace front bracket assembly or rear bracket assembly.



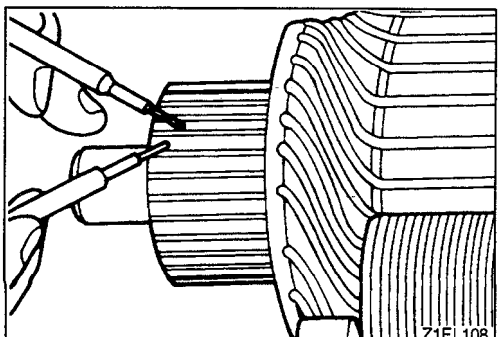
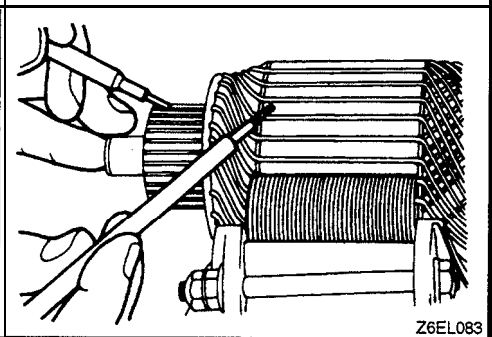
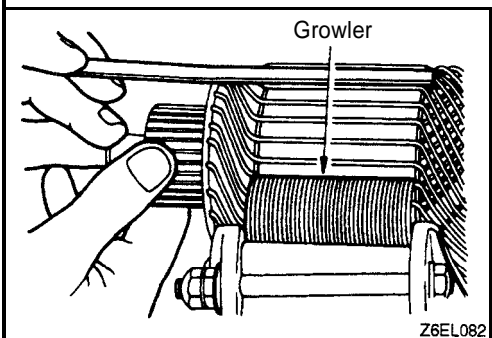
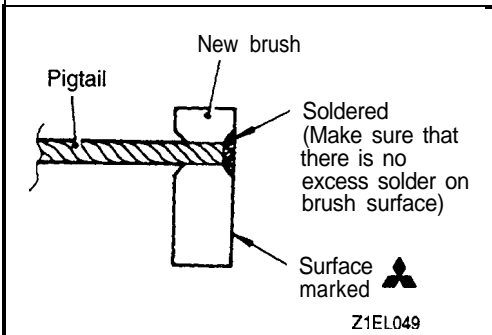
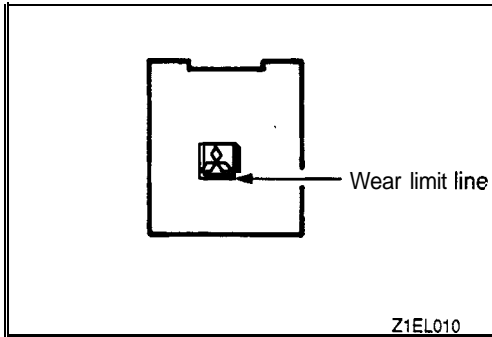

## BRUSHES AND SPRINGS REPLACEMENT

1. Brushes that are worn beyond wear limit line, or oil-soaked, should be replaced.
2. When replacing field coil brushes, crush worn brush with pliers, being careful not to damage pigtail.

3. Sand pigtail end with sandpaper to ensure good soldering.
4. Insert pigtail into hole provided in new brush and solder it.  
Make sure that pigtail and excess solder do not come out onto brush surface.
5. When replacing ground brush, slide the brush from brush holder by prying retaining spring back.

## ARMATURE TEST

### ARMATURE SHORT-CIRCUIT TEST

1. Place armature in a growler.
2. Hold a thin steel blade parallel and just above while rotating armature slowly in growler. A shorted armature will cause blade to vibrate and be attracted to the core. Replace shorted armature.

### ARMATURE GROUNDING TEST

Check the insulation between the armature coil cores and the commutator segments. They are normal if there is no continuity.

### ARMATURE COIL OPEN-CIRCUIT CHECK

Check for continuity between segments. The condition is normal if there is continuity.

# IGNITION SYSTEM

## SPECIFICATIONS

### GENERAL SPECIFICATIONS

#### CRANK ANGLE SENSOR <Up to 1992 model>

Items	Specifications
Type	Contact pointless type
Identification No.	T1 T49371
Part No.	MD1 53464
Advance mechanism	Controlled by engine control unit
Firing order	1 - 2 - 3 - 4 - 5 - 6

### IGNITION COIL

Items	Specifications
Type	Mold 3-coil
Identification No.	F-536
Part No.	MD152648

### SPARK PLUG

Items	Specifications
NGK	PFR6J-11
NIPPON DENSO	PK20PR-P11

### SERVICE SPECIFICATIONS

Items	Standard value	Limit
Ignition coil	Primary coil resistance at 20°C (68°F) $\Omega$	0.67–0.81
	Secondary coil resistance at 20°C (68°F) $k\Omega$	11.3–15.3
Spark plug gap mm (in.)	1.0–1.1 (0.39-0.43)	1.3 (.051)
Spark plug cable $k\Omega$		Max. 22

### SPECIAL TOOLS

Tool number and name	Supersession	Application
 MD998464 Harness connector (4 pin, square)		Check of ignition primary voltage (connection of ignition coil connector)

**TROUBLESHOOTING (UP TO 1993 MODELS)**

**CIRCUIT DIAGRAM**

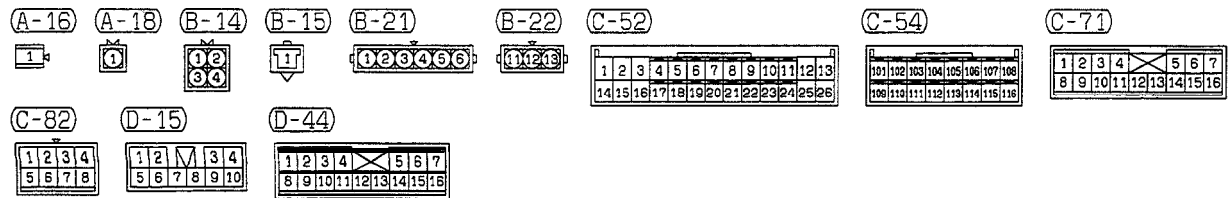
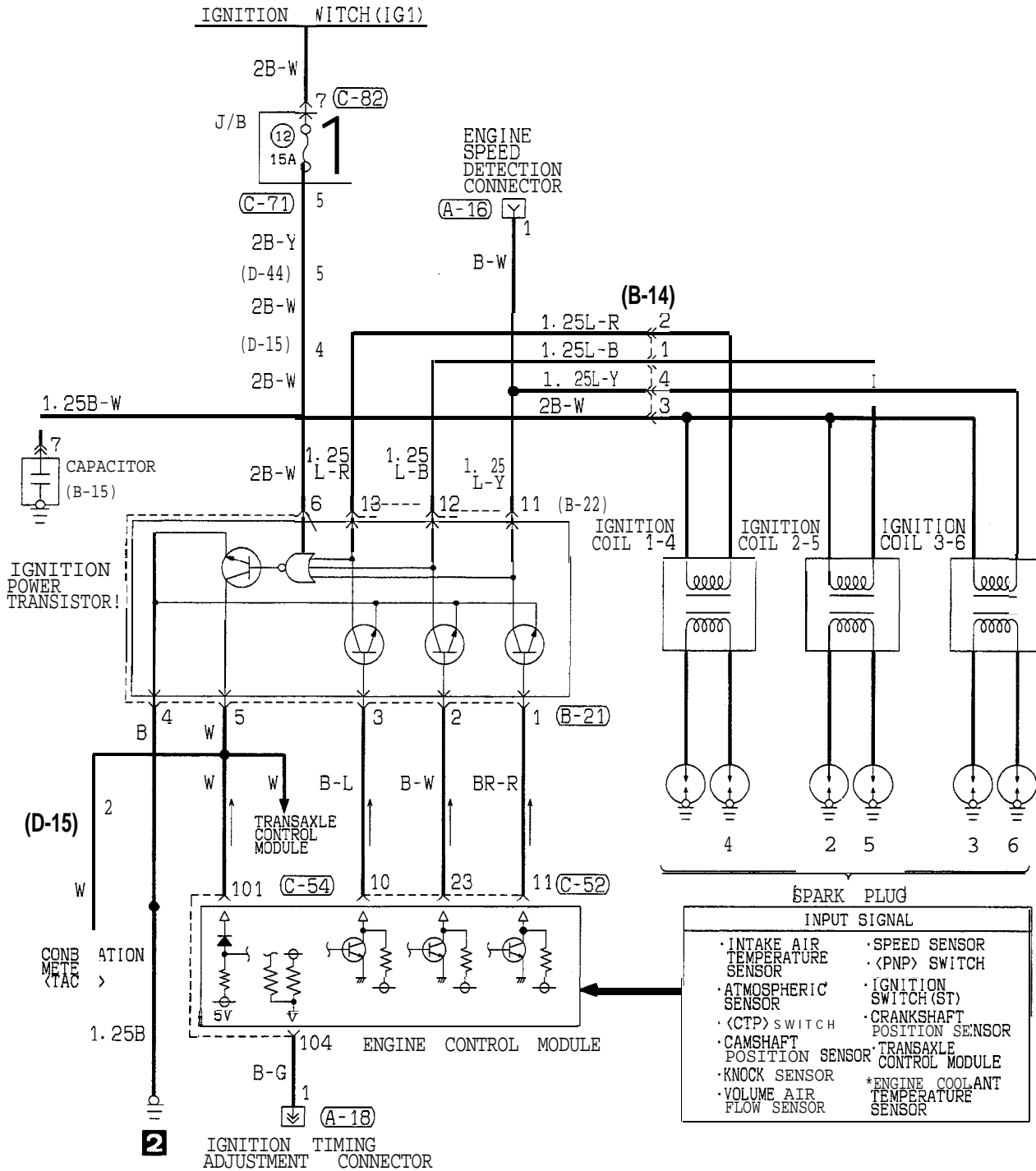

(UP TO 1995 MODELS)

CIRCUIT DIAGRAM

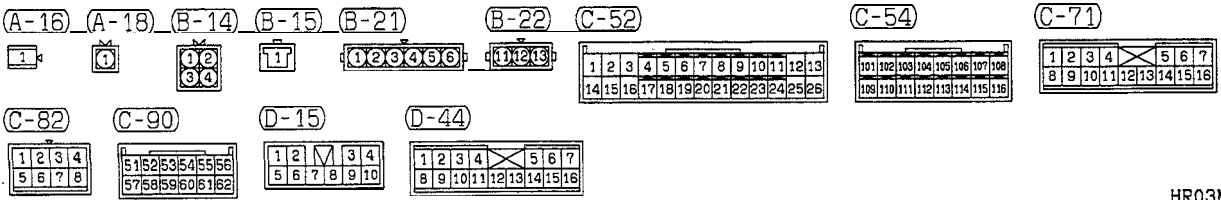
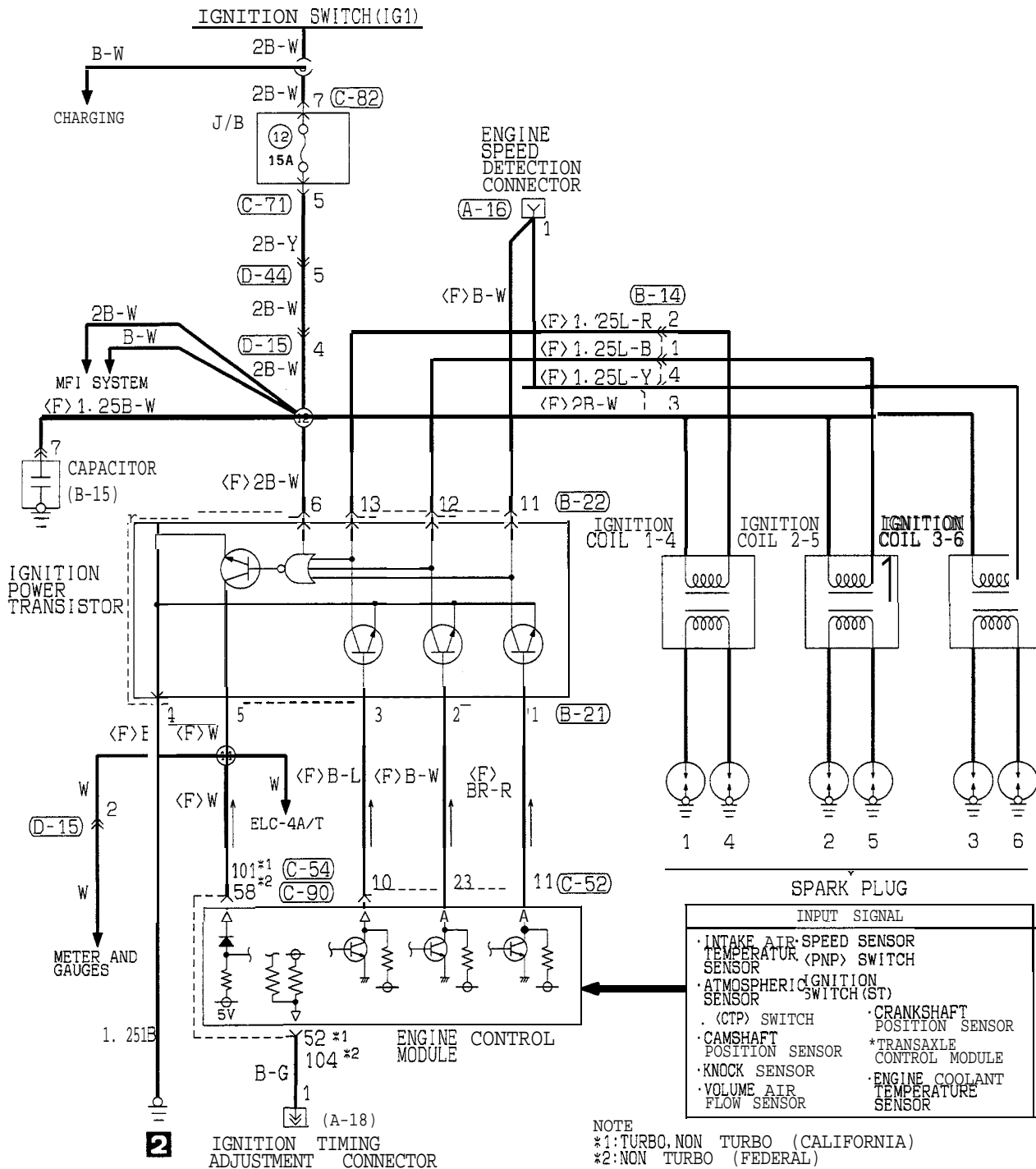

HR03M01AA

(FROM 1996 MODELS)

CIRCUIT DIAGRAM

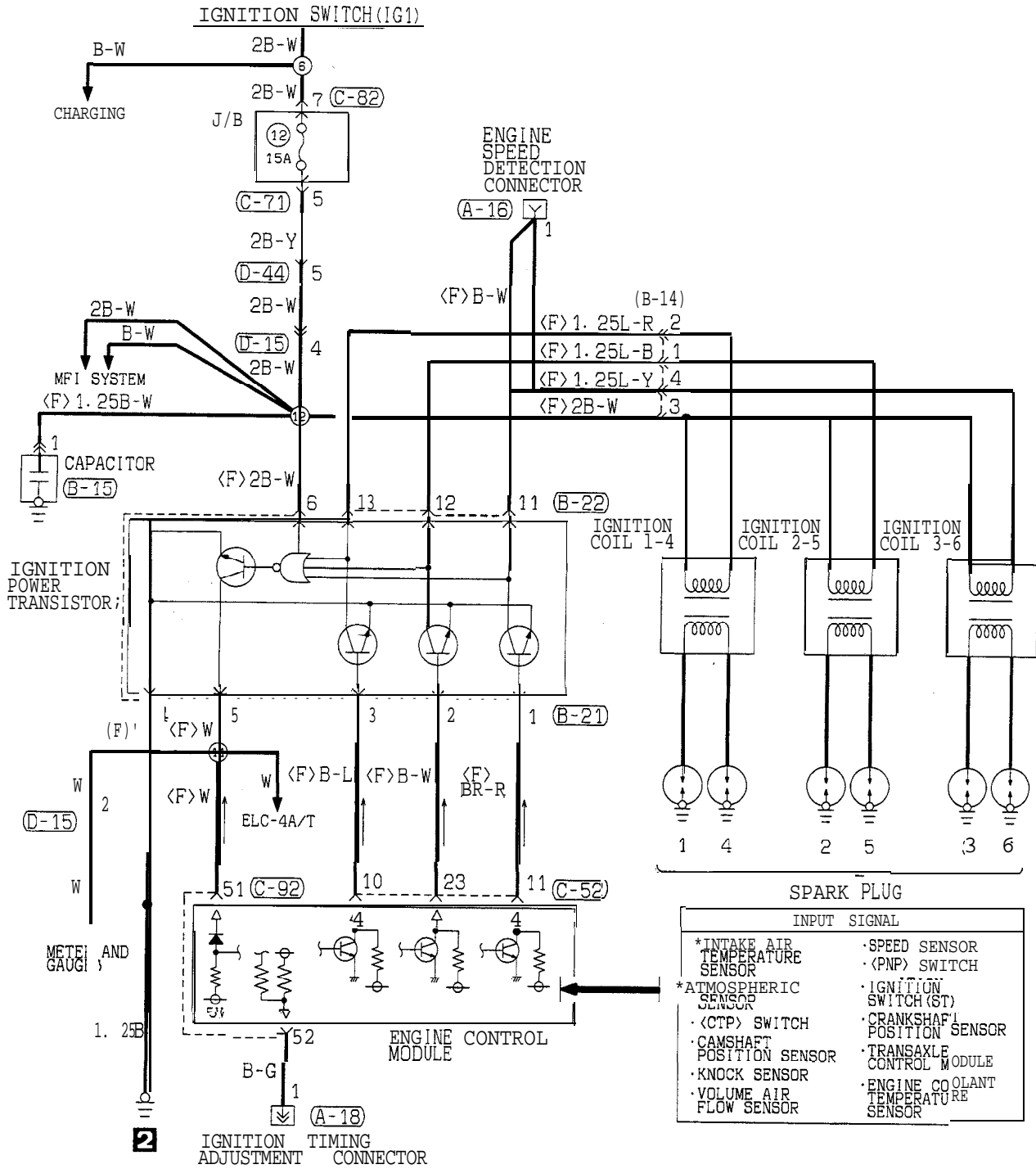

- | INPUT SIGNAL                   |                                    |
|--------------------------------|------------------------------------|
| *INTAKE AIR TEMPERATURE SENSOR | ·SPEED SENSOR                      |
| *ATMOSPHERIC SENSOR            | ·(PNP) SWITCH                      |
| ·(CTP) SWITCH                  | ·IGNITION SWITCH (ST)              |
| ·CAMSHAFT POSITION SENSOR      | ·CRANKSHAFT POSITION SENSOR        |
| ·KNOCK SENSOR                  | ·TRANSAXLE CONTROL MODULE          |
| ·VOLUME AIR FLOW SENSOR        | ·ENGINE COOLANT TEMPERATURE SENSOR |

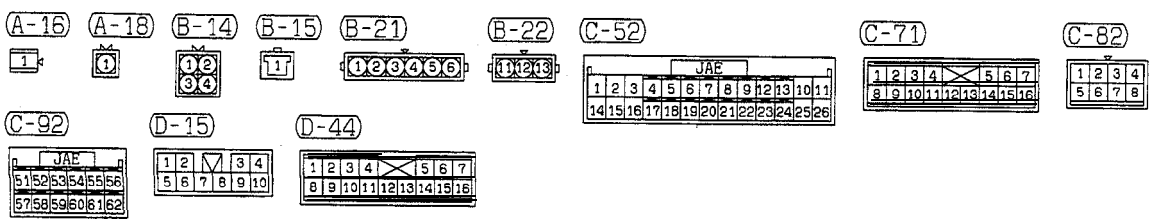

**OPERATION**

- Turn ignition switch to .“ON” position, and battery voltage will be applied to primary winding of ignition coil.
- When crankshaft position sensor and camshaft position sensor signal is input to engine control module, engine control module makes ON-OFF control of power transistors one by one.
- When power transistor is turned on, current flows from ignition coil (primary winding) to ground through power transistor.
- When power transistor A is turned from ON to OFF, the spark plugs of No. 1 and No. 4 cylinders spark. Turning of power transistor B from ON to OFF will produce sparking in spark plugs of No. 2 and No. 5 cylinders. Furthermore, when power transistor C is turned from ON to OFF, sparking is produced in spark plugs of No. 3 and No. 6 cylinders.

**TROUBLESHOOTING HINTS**

1. Engine cranks, but does not start.
  - (1) Spark is insufficient or does not occur at all (on spark plug).
    - Check ignition coil.
    - Check camshaft position sensor and crankshaft position sensor
    - Check power transistor.
    - Check spark plugs.
    - Check spark plug cable.
  - (2) Spark is good.
    - Check ignition timing.
2. Engine idles roughly or stalls.
  - Check spark plugs.
  - Check ignition timing.
  - Check ignition coil.
  - Check spark plug cable.
3. Poor acceleration
  - Check ignition timing.
  - Check spark plug cable.
  - Check ignition coil.

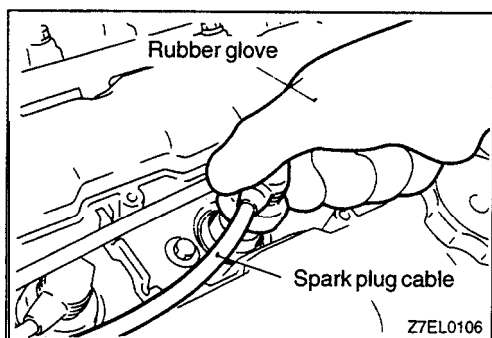

## ON-VEHICLE SERVICE

### SPARK PLUG CABLE TEST

- (1) Disconnect, one at a time, each of the spark plug cables while the engine is idling to check whether the engine's running performance changes or not.

#### Caution

**Wear rubber gloves while doing so.**

- (2) If the engine performance does not change, check the resistance of the spark plug cable, and check the spark plug itself.

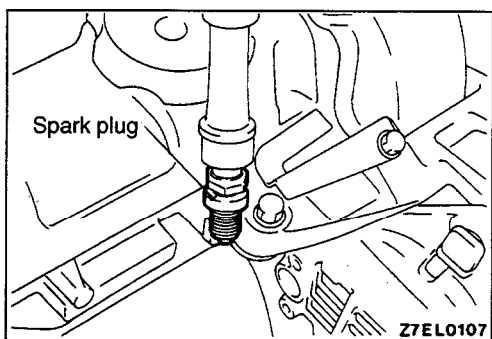

### SPARK PLUG TEST

- (1) Remove the spark plug and connect to the spark plug cable.
- (2) Ground the spark plug outer electrode (body), and crank the engine.  
Check to be sure that there is an electrical discharge between the electrodes at this time.

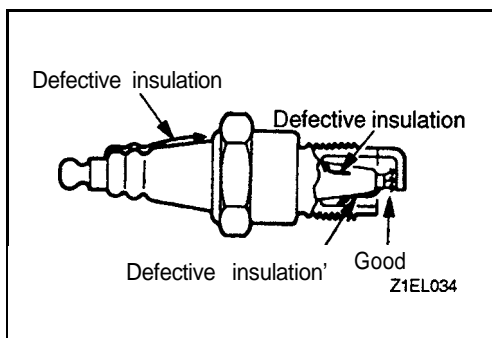

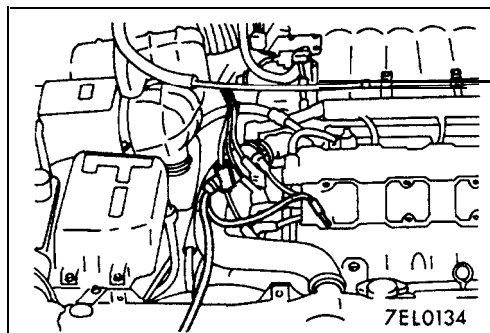

## IGNITION SECONDARY VOLTAGE WAVE-FORM CHECK

### MEASUREMENT METHOD

- (1) Clamp SECONDARY PICKUP around spark plug cable.

#### NOTE

1. The ignition voltage peak appears reversely between when the spark plug cables of the cylinders No.4, No. 5 and No. 6 are clamped and when those of the cylinders No. 1, No. 2 and No. 3 are clamped.
2. Since the 2-cylinder simultaneous ignition system is employed, the wave-form for two cylinder appears group by group when the wave-form is observed. (Cylinder No. 1 – cylinder No. 4, cylinder No. 2 – cylinder No. 5 and cylinder No. 3 – cylinder No. 6 as the respective groups) Here, the wave-form is observed for the cylinder whose spark plug cable is clamped with the secondary pickup.

- (2) Clamp the spark plug cable with the trigger pickup.

#### NOTE

1. Clamp the spark plug cable of the cylinders No.1, No. 2 or No. 3 which belongs to the same group of the cylinders clamped with the secondary pickup.
2. Though it is difficult to isolate the cylinder of the wave-form, the wave-form of the cylinders clamped with the secondary pickup is stable. Use this as a reference for isolation.



STANDARD WAVE-FORM

Observation Conditions

FUNCTION	SECONDARY
PATTERN HEIGHT	HIGH (or LOW)
PATTERN SELECTOR	RASTER
Engine revolutions	Curb idle speed

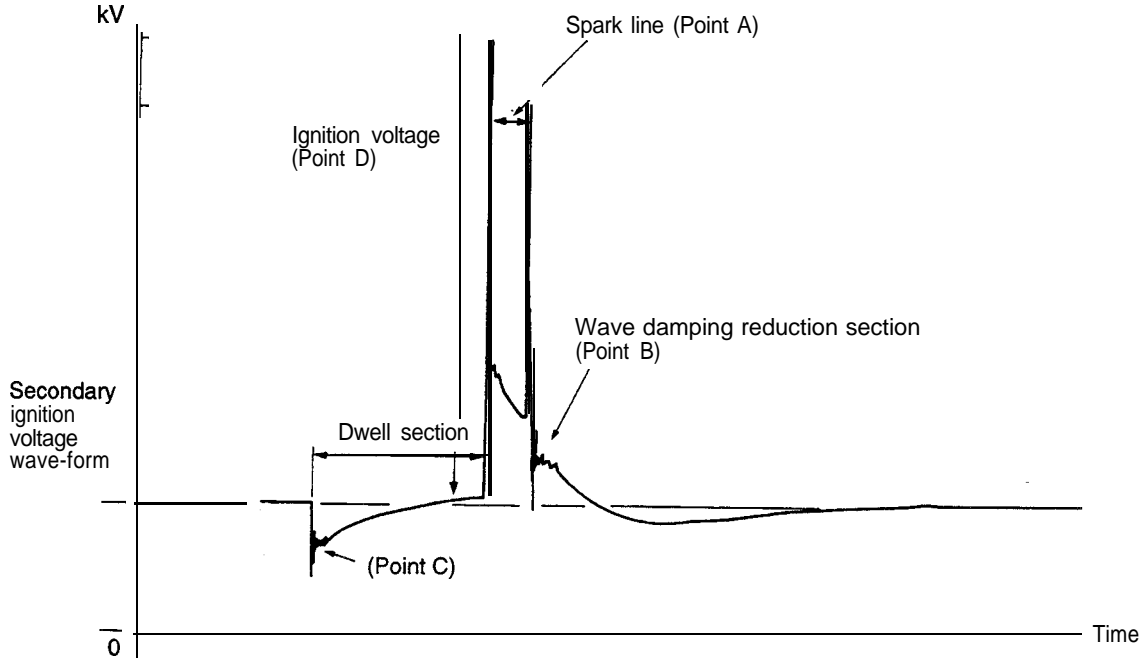

7EL0147

Observation conditions (Only PATTERN SELECTOR below changes from the above conditions)

PATTERN SELECTOR	DISPLAY
------------------	---------

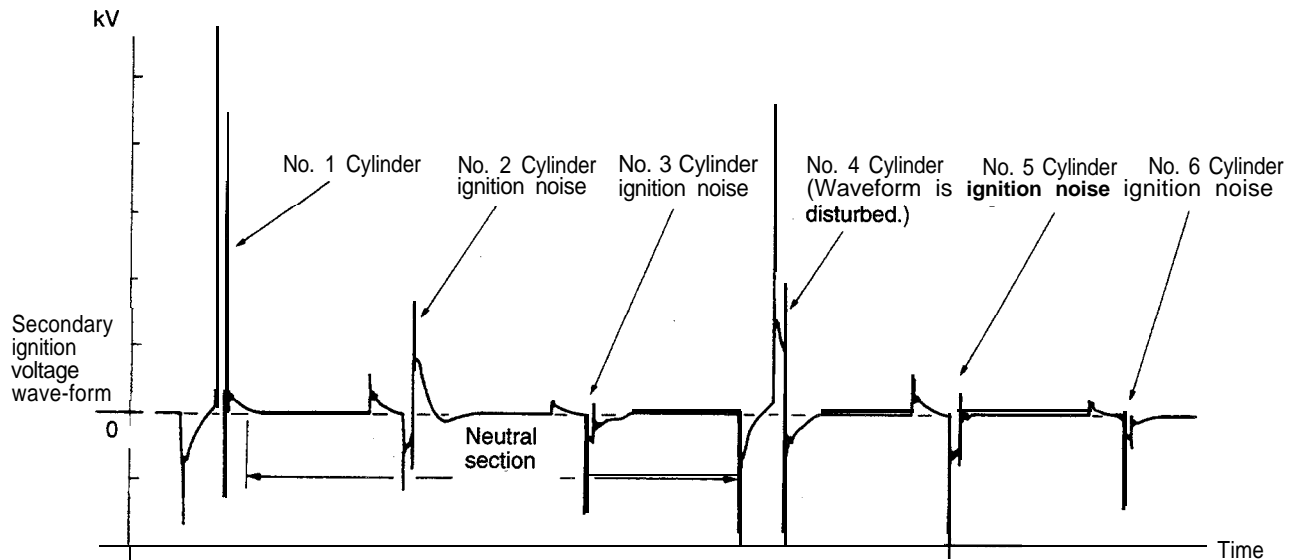

7EL0148

**Wave-form Observation Points**

Point A: The height, length and slope of the spark line (refer to abnormal wave-form examples 1, 2, 3 and 4) show the following trends.

Spark line		Plug gap	Condition of electrode	Compression force	Concentration of air mixture	Ignition timing	Spark plug cable
Length	Long	Small	Normal.	Low	Rich	Advanced	Leak
	Short	Large	Large wear	High	Lean	Retarded	High resistance
Height	High	Large	Large wear	High	Lean	Retarded	High resistance
	Low	Small	Normal	Low	Rich	Advanced	Leak
Slope		Large	Plug is fouled	–			

Point B: Number of vibrations in reduction vibration section (Refer to abnormal wave-form example 5)

Number of vibrations	Coil and condenser
Three or more	Normal
Except above	Abnormal



Point C: Number of vibrations at beginning of dwell section (Refer to abnormal wave-form example 5)

Number of vibrations	Coil
5 – 6 or higher	Normal
Except above	Abnormal

Point D: Ignition voltage height (distribution per each cylinder) shows the following trends.

Ignition voltage	Plug gap	Condition of electrode	Compression force	Concentration of air mixture	Ignition timing	Spark plug cable
High	Large	Large wear	High	Lean	Retarded	High resistance
Low	Small	Normal	Low	Rich	Advanced	Leak

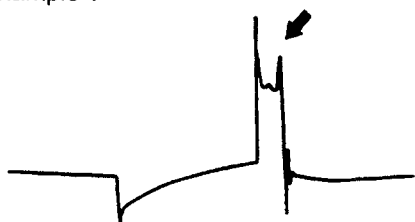
EXAMPLES OF ABNORMAL WAVE-FORMS

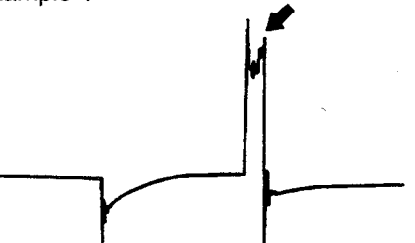
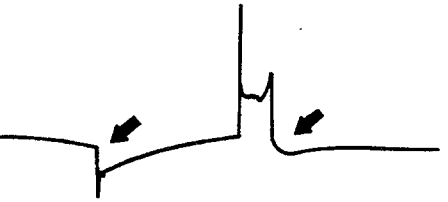
Abnormal wave-form	Wave characteristics	Cause of problem
<p>Example 1</p>  <p>Z01P0215</p>	<p>Spark line is high and short.</p>	<p>Spark plug gap is too large.</p>
<p>Example 2</p>  <p>Z01P0216</p>	<p>Spark line is low and long, and is sloping. Also, the second half of the spark line is distorted. This could be a result of misfiring.</p>	<p>Spark plug gap is too small.</p>
<p>Example 3</p>  <p>Z01P0217</p>	<p>Spark line is low and long, and is sloping. However, there is almost no spark line distortion.</p>	<p>Spark plug gap is fouled.</p>
<p>Example 4</p>  <p>Z01P0218</p>	<p>Spark line is high and short. Difficult to distinguish between this and abnormal wave-form example 1.</p>	<p>Spark plug cable is nearly falling off. (Causing a dual ignition)</p>
<p>Example 5</p>  <p>Z01P0219</p>	<p>No waves in wave damping section.</p>	<p>Rare short in ignition coil.</p>

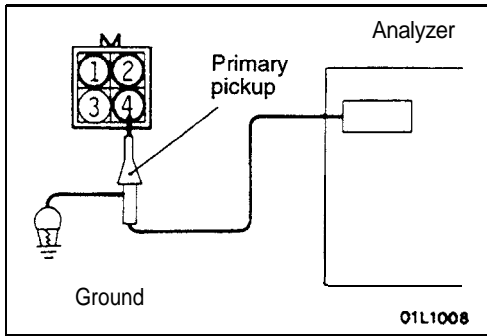

### IGNITION PRIMARY VOLTAGE WAVE-FORM CHECK

#### MEASUREMENT METHOD

- (1) Remove the ignition coil connector and connect the special tool (harness connector: MD998464) in between.
- (2) When observing the No. 1 – No. 4 cylinder group, connect the primary pickup of the analyzer probe to the ignition coil side connector terminal No. 2 (black clip on the special tool).  
For the No. 2 – No. 5 cylinder group, connect to terminal No. 1 (red clip), and for the No. 3 – No. 6 cylinder group, connect to terminal No. 4 (white clip).
- (3) Ground the primary pickup ground terminal.
- (4) Clamp the spark plug cable with the trigger pickup.

#### NOTE

- (1) Clamp the spark plug cable of cylinder No. 1, No. 2 or No. 3 which belongs to the same group of the cylinder to which the primary pickup is connected.
- (2) The wave-form of any cylinder in the same group is displayed on the left side of the screen.

### STANDARD WAVE-FORM

#### Observation Conditions

FUNCTION	PRIMARY
PATTERN HEIGHT	HIGH (or LOW)
PATTERN SELECTOR	RASTER
Engine revolutions	Curb idle speed

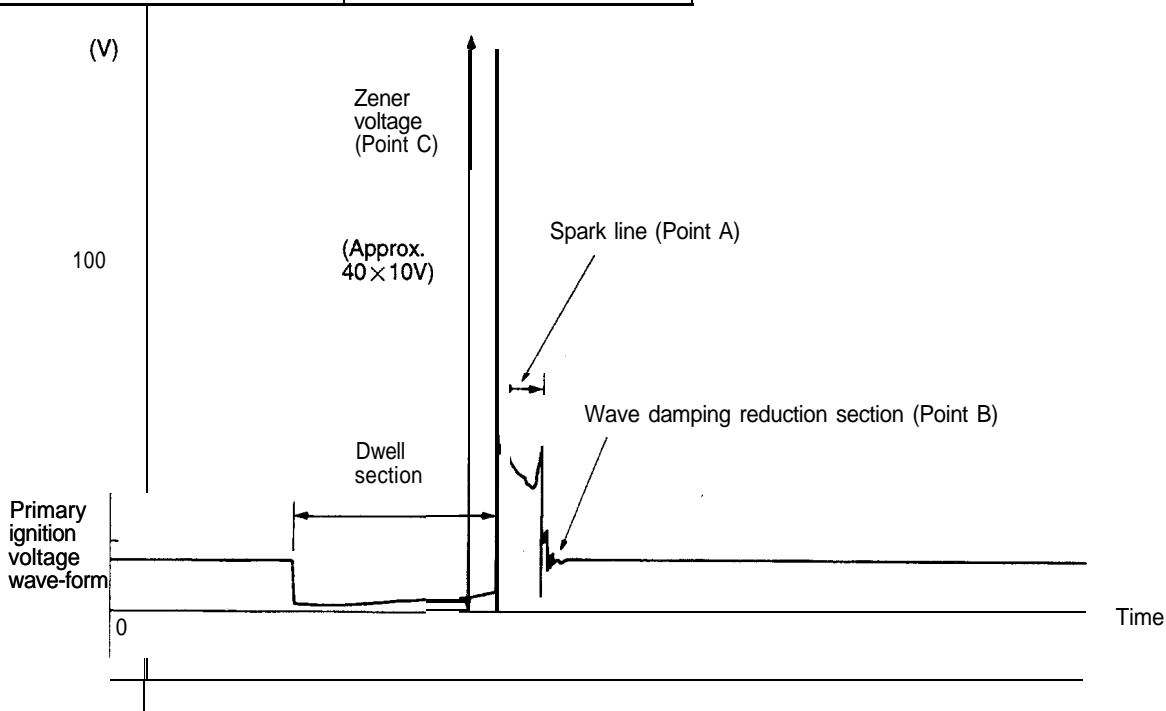

7EL0149

Observation conditions (Only PATTERN SELECTOR below changes from the above conditions.)

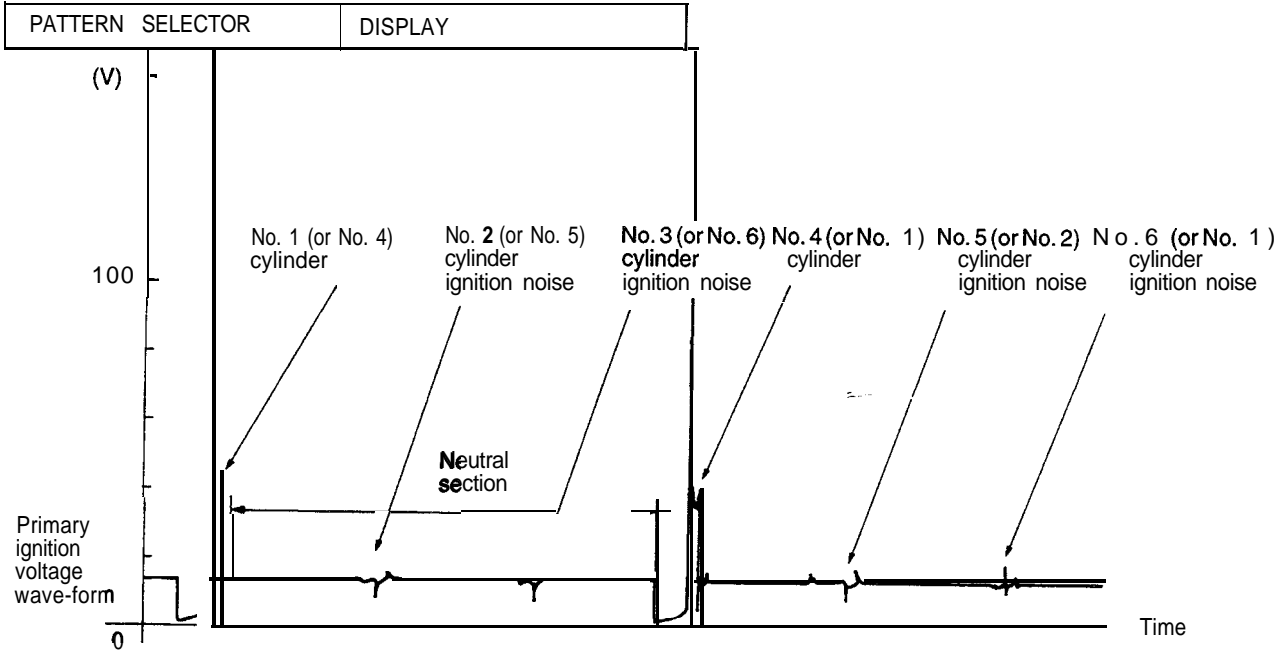

7E0151

**Wave-form Observation Points**

Point A: The height, length and slope of the spark line (refer to abnormal wave-form examples 1, 2, 3 and 4) show the following trends.

Spark line		Plug gap	Condition of electrode	Compression force	Concentration of air mixture	Ignition timing	High tension cable
Length	Long	Small	Normal	Low	Rich	Advanced	Leak
	Short	Large	Large wear	High	Lean	Retarded	High resistance
Height	High	Large	Large wear	High	Lean	Retarded	High resistance
	Low	Small	Normal	Low	Rich	Advanced	Leak
Slope		Large	Plug is fouled	–			



Point B: Number of vibrations in reduction vibration section (Refer to abnormal wave-form example 5)

Number of vibrations	Coil and condenser
3 or higher	Normal
Except above	Abnormal

Point C: Height of Zener voltage

Height of Zener voltage	Probable cause
Higher	Problem in Zener diode
Lower	Abnormal resistance in primary coil circuit

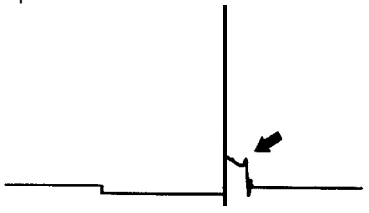
EXAMPLES OF ABNORMAL WAVE-FORMS

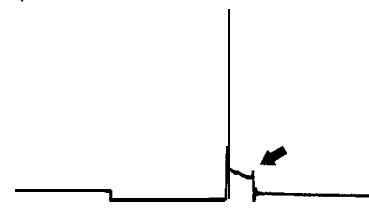
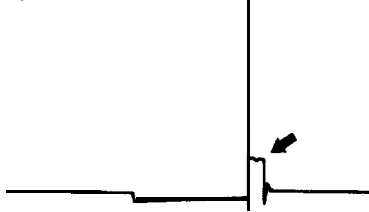
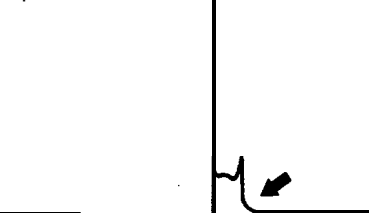
Abnormal wave-form	Wave characteristics	Cause of problem
<p>Example 1</p>  <p>Z01P0210</p>	<p>Spark line is high and short.</p>	<p>Spark plug gap is too large.</p>
<p>Example 2</p>  <p>Z01P0211</p>	<p>Spark line is low and long, and is sloping. Also, the second half of the spark line is distorted. This could be a result of misfiring.</p>	<p>Spark plug gap is too small.</p>
<p>Example 3</p>  <p>Z01P0212</p>	<p>Spark line is low and long, and is sloping. However, there is almost no spark line distortion.</p>	<p>Spark plug gap is fouled.</p>
<p>Example 4</p>  <p>Z01P0213</p>	<p>Spark line is high and short.</p>	<p>Spark plug cable is nearly falling off. (Causing a dual ignition)</p>
<p>Example 5</p>  <p>Z01P0214</p>	<p>No waves in wave damping section.</p>	<p>Rare short in ignition coil.</p>

# IGNITION SYSTEM

## REMOVAL AND INSTALLATION

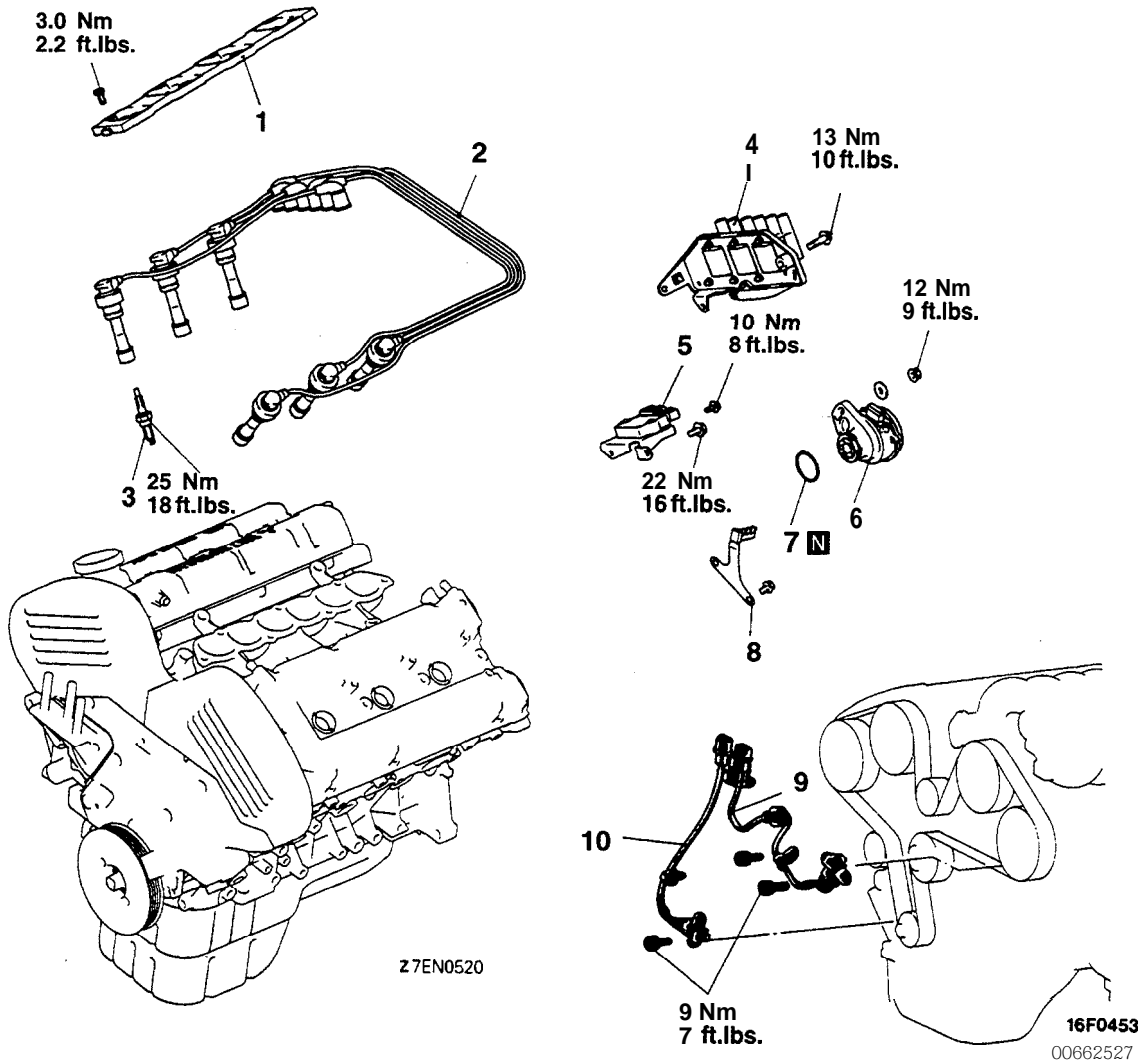

### Removal steps

- Intake manifold plenum (Refer to GROUP 15 – Intake Manifold.)

►B◄

1. Center cover
2. Spark plug cable
3. Spark plug
4. Ignition coil

►A◄

5. Ignition power transistor
6. Crankshaft position sensor  
<1 992 models>

7. O-ring <1992 models>
8. Clamp <From 1993 models>  
Camshaft position sensor, Crankshaft position sensor removal steps <From 1993 models>
  - Timing belt cover (Refer to GROUP 11 – Timing Belt)
9. Camshaft position sensor
10. Crankshaft position sensor



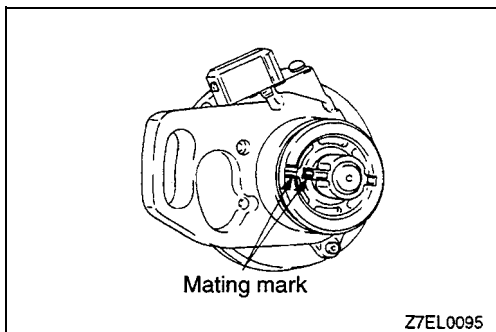

### INSTALLATION SERVICE POINTS

#### ▶A◀CRANKSHAFT POSITION SENSOR INSTALLATION <Up to 1992 model>

- (1) Turn the crankshaft so that the No. 1 cylinder is at compression top dead center.

#### Caution

Be careful not to turn it to the No. 4 cylinder compression top dead center by mistake.

- (2) Install, lining up the matchmarks on the crankshaft position sensor housing and the coupling.

#### ▶B◀SPARK PLUG CABLE INSTALLATION

Improper arrangement of spark plug cables will induce voltage between the cables, causing miss firing and developing a surge at acceleration in high-speed operation. Therefore, be careful to arrange the spark plug cables properly by the following procedure.

1. install the spark plug cable clamps as shown in the illustration.
2. The numerals on the support and clamp indicate the spark plug cable No.
3. Pay attention to the following items when the spark plug cables are installed.
  - (1) Install the cables securely to avoid possible contact with metal parts.
  - (2) Install the cables neatly, ensuring they are not too tight, loose, twisted or kinked.

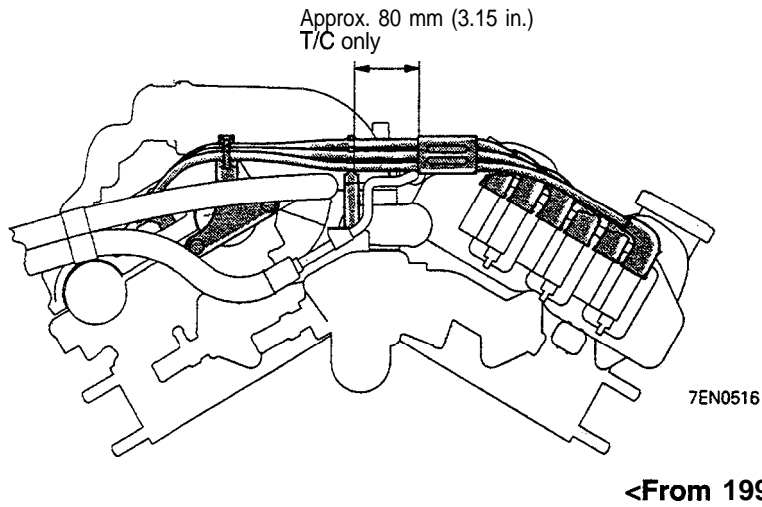
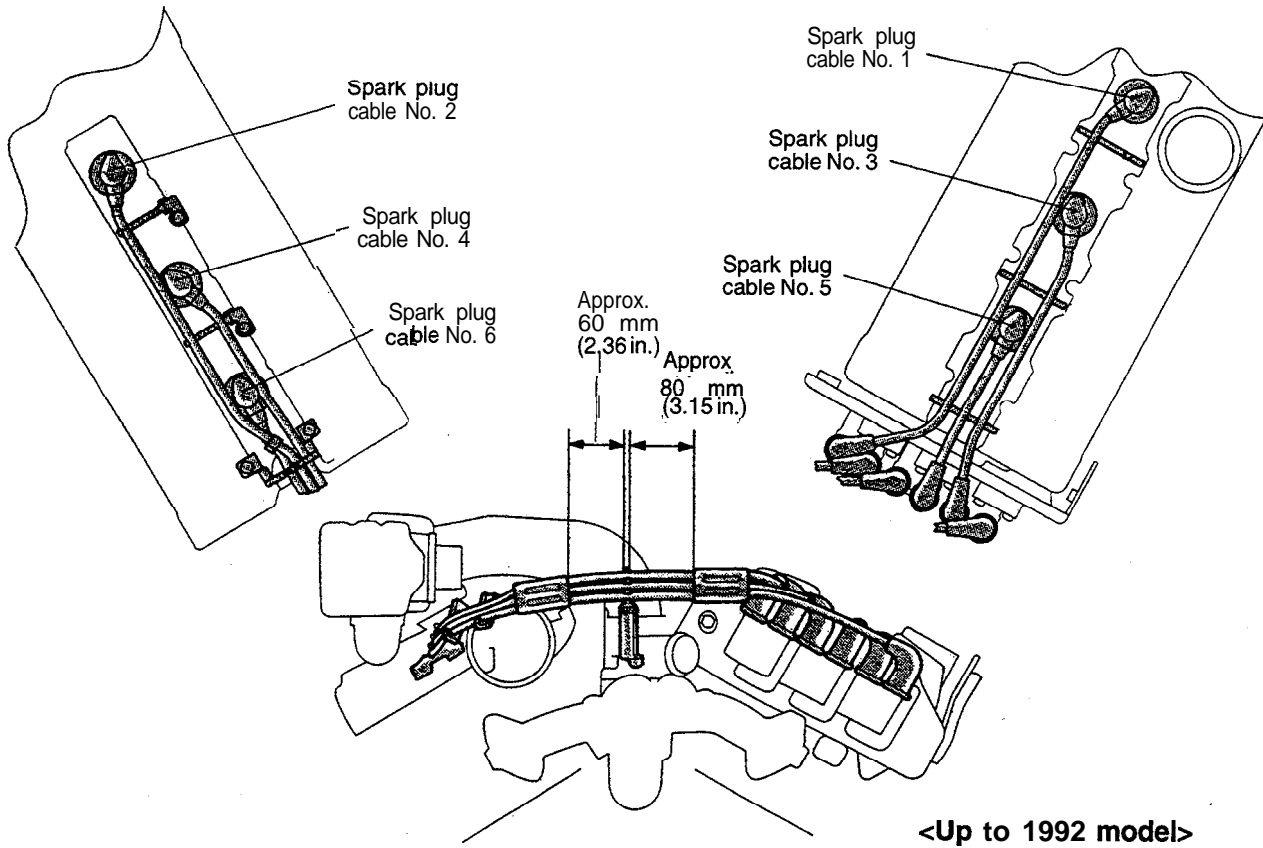

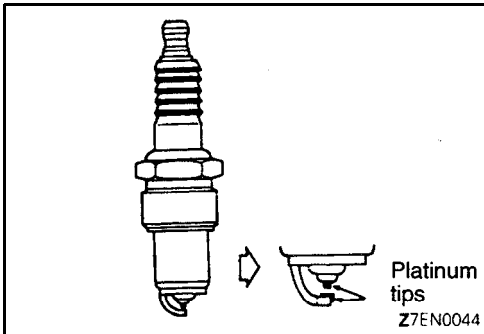

**INSPECTION  
SPARK PLUG**

Check the plug gap and replace if the limit is exceeded.

**Standard value: 1.0–1.1 mm (.039–.043 in.)**

**Limit: 1.3 mm (.051 in.)**

**Caution**

1. Do not attempt to adjust the gap of the platinum plug.
2. Cleaning of the platinum plug may damage the platinum tip. Therefore, if carbon deposits must be removed, use a plug cleaner and complete cleaning within 20 seconds for protection of the electrode. Do not use wire brushes.

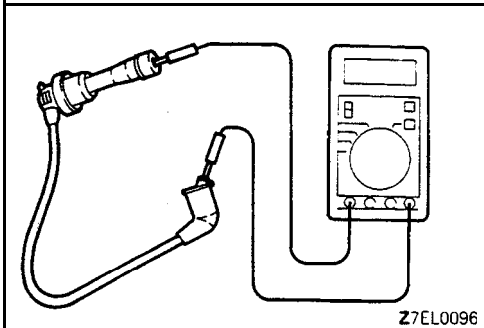

**SPARK PLUG CABLE**

- (1) Check cap and coating for cracks.
- (2) Measure resistance.

**Limit: Max. 22 kΩ**

**IGNITION POWER TRANSISTOR**

**NOTE**

An analog-type circuit tester should be used.

**No. 1-No. 4 coil side**

- (1) Connect the negative (–) terminal of the 1.5 V power supply to terminal (4) of the ignition power transistor; then check whether there is continuity between terminal (13) and terminal (4) when terminal (3) and the positive (+) terminal are connected and disconnected.

**N O T E**

Connect the (–) probe of the circuit tester to terminal (13).

Terminal 3 and (+) terminal	Terminal 13 and terminal 4
Connected	Continuity
Unconnected	No continuity

- (2) Replace the ignition power transistor if there is a malfunction.

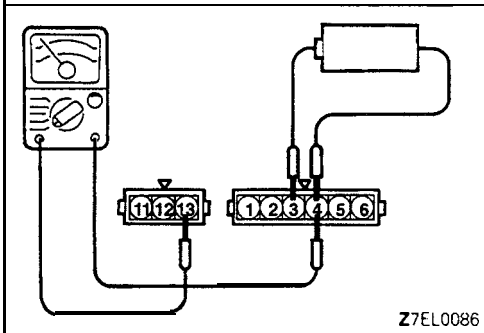

**No. 2–No. 5 coil side**

- (1) Connect the negative (–) terminal of the 1.5 V power supply to terminal (4) of the ignition power transistor; then check whether there is continuity between terminal (12) and terminal (4) when terminal (2) and the positive (+) terminal are connected and disconnected.

**NOTE**

Connect the (–) probe of the circuit tester to terminal (12).

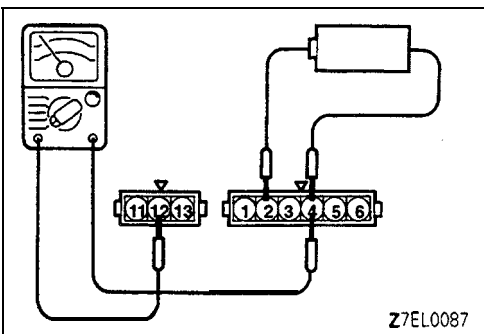

Terminal 2 and (+) terminal	Terminal 12 and terminal 4
Connected	Continuity
Unconnected	No continuity

- (2) Replace the ignition power transistor if there is a malfunction.

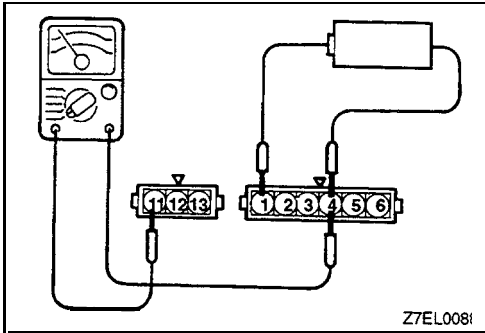

**No. 3–No. 6 coil side**

- (1) Connect the negative (–) terminal of the 1.5 V power supply to terminal (4) of the ignition power transistor; then check whether there is continuity between terminal (11) and terminal (4) when terminal (1) and the positive (+) terminal are connected and disconnected.

**NOTE**

Connect the (–) probe of the circuit tester to terminal 11.

Terminal 1 and (+) terminal	Terminal 11 and terminal 4
Connected	Continuity
Unconnected	No continuity

- (2) Replace the ignition power transistor if there is a malfunction.

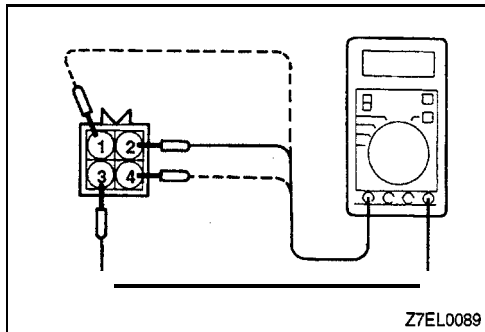

**IGNITION COIL**

**Primary Coil Resistance**

Measure the resistance between connector terminal (3) (power) and each coil terminal.

**Measuring point:**

- Coil A (No.1–No.4 cylinder side coil) . . . . . (2)–(3)
- Coil B (No.2–No.5 cylinder side coil) . . . . . (1)–(3)
- Coil C (No.3–No.6 cylinder side coil) . . . . . (4)–(3)

**Standard value: 0.67-0.81 Ω**

**Secondary Coil Resistance**

Measure the resistance between each coil high voltage terminals.

**Measuring point:**

- Coil A (No. 1–No. 4 cylinder side coil)
- Coil B (No. 2–No. 5 cylinder side coil)
- Coil C (No. 3–No. 6 cylinder side coil)

**Standard value: 11.3-15.3 kΩ**

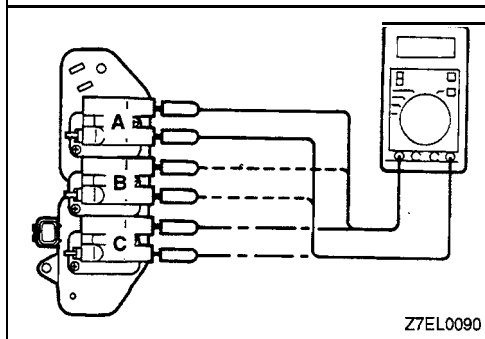

---

NOTES



# CHASSIS ELECTRICAL

## CONTENTS

<b>AERO PARTS (ACTIVE AERO) . . . . .</b>	Refer to GROUP 51	<b>CRUISE CONTROL SYSTEM . . . . .</b>	Refer to GROUP 17
<b>ANTI-LOCK BRAKING SYSTEM . . . . .</b>	Refer to GROUP 35	<b>DOOR GLASS AND REGULATOR (POWER WINDOWS) . . . . .</b>	Refer to GROUP 42
<b>BATTERY . . . . .</b>	3	<b>DOOR HANDLE AND LATCH (CENTRAL DOOR LOCKING) . . . . .</b>	Refer to GROUP 42
<b>ON-VEHICLE SERVICE . . . . .</b>	3	<b>DOOR MIRROR (ELECTRONIC CONTROLLED MIRROR). . . . .</b>	Refer to GROUP 51
Battery Charging . . . . .	4	<b>ELECTRONIC CONTROL SUSPENSION . . . . .</b>	Refer to GROUP 33B
Battery Inspection . . . . .	3	<b>FRONT SEAT (POWER SEAT) . . . . .</b>	Refer to GROUP 52A
Battery Testing Procedure . . . . .	5	<b>HEATER AND AIR CONDITIONING . . . . .</b>	Refer to GROUP 55
<b>SPECIFICATIONS . . . . .</b>	3	<b>HORN . . . . .</b>	115
General Specifications . . . . .	3	<b>HORN SWITCH* . . . . .</b>	118
<b>CIGARETTE LIGHTER . . . . .</b>	119	<b>RELAY . . . . .</b>	118
<b>CIGARETTE LIGHTER . . . . .</b>	123	<b>SPECIFICATIONS . . . . .</b>	115
<b>SPECIFICATIONS . . . . .</b>	119	General Specifications . . . . .	115
General Specifications . . . . .	119	<b>TROUBLESHOOTING . . . . .</b>	115
<b>TROUBLESHOOTING . . . . .</b>	120	<b>KEYLESS ENTRY SYSTEM (CENTRAL DOOR LOCKING) . . . . .</b>	Refer to GROUP 42
<b>COLUMN SWITCH . . . . .</b>	111	CONTINUED ON NEXT PAGE	
<b>COLUMN SWITCH* . . . . .</b>	112		
<b>SPECIAL TOOL . . . . .</b>	111		
<b>SPECIFICATIONS . . . . .</b>	111		
General Specifications . . . . .	111		

### WARNINGS REGARDING SERVICING OF SUPPLEMENTAL RESTRAINT SYSTEM (SRS) EQUIPPED VEHICLES

#### WARNING!

- (1) Improper service or maintenance of any component of the SRS, or any SRS-related component, can lead to personal injury or death to service personnel (from inadvertent firing of the air bag) or to the driver and passenger (from rendering the SRS inoperative).
- (2) Service or maintenance of any SRS component or SRS-related component must be performed only at an authorized MITSUBISHI dealer.
- (3) MITSUBISHI dealer personnel must thoroughly review this manual, and especially its GROUP 52B – Supplemental Restraint System (SRS) and GROUP 00 -Maintenance Service before beginning any service or maintenance of any component of the SRS or any SRS-related component.

#### NOTE

The SRS includes the following components: impact sensors, SRS diagnosis unit, SRS warning light, air bag module, clock spring and interconnecting wiring. Other SRS-related components (that may have to be removed/installed in connection with SRS service or maintenance) are indicated in the table of contents by an asterisk (\*).

IGNITION SWITCH* .....	6	REAR WINDOW DEFOGGER .....	192
IGNITION SWITCH .....	-	DEFOGGER RELAY .....	204
SPECIAL TOOL .....	6	ON-VEHICLE SERVICE .....	203
		REAR WINDOW DEFOGGER SWITCH .....	203
LIGHTING SYSTEM .....	35	SPECIAL TOOLS.. .....	192
FOG LIGHT .....	105	TROUBLESHOOTING .....	193
FRONT COMBINATION LIGHT AND OPTICAL HORN LENS .....	106	REAR WIPER AND WASHER .....	Refer to GROUP 51
HAZARD SWITCH .....	110	SEAT BELT (BUZZER).. .....	Refer to GROUP 52A
HEADLIGHT .....	103	SEAT BELT (TENSION-REDUCER TYPE SEAT BELT) .....	Refer to GROUP 52A
HIGH MOUNTED STOP LIGHT .....	107	SUPPLEMENTAL RESTRAINT SYSTEM (SRS) .....	Refer to GROUP 52B
ON-VEHICLE SERVICE .....	100		
POP-UP SWITCH AND FOG LIGHT SWITCH ....	109	THEFT-ALARM SYSTEM .....	205
REAR COMBINATION LIGHT AND LICENSE PLATE LIGHT .....	106	SPECIAL TOOLS.. .....	205
RELAY .....	108	TROUBLESHOOTING .....	206
RHEOSTAT .....	110		
SPECIAL TOOLS .....	36	WINDSHIELD WIPER AND WASHER .....	Refer to GROUP 51
SPECIFICATIONS .....	35		
General Specifications .....	35		
Service Specifications .....	35		
TROUBLESHOOTING .....	37		
METERS AND GAUGES .....	9		
COMBINATION GAUGES .....	33		
COMBINATION METERS .....	31		
ON-VEHICLE SERVICE .....	26		
SPECIFICATIONS .....	9		
General Specifications .....	9		
Sealant .....	11		
Service Specifications .....	11		
TROUBLESHOOTING .....	12		
RADIO AND TAPE PLAYER .....	124		
CD AUTO CHANGER .....	191		
RADIO AND TAPE PLAYER WITH ANTI-THEFT SYSTEM .....	156		
MOTOR ANTENNA/ANTENNA FEEDER CABLE/AMPLIFIER .....	188		
RADIO AND TAPE PLAYER .....	186		
RADIO REMOTE-CONTROL* .....	186		
SPEAKER .....	187		
TROUBLESHOOTING .....	124		

# BATTERY

## SPECIFICATIONS

### GENERAL SPECIFICATIONS

Items	Up to 1993 models	From 1994 models
Type	75D26R-MF	75D23R-MF
Ampere hours (5HR) Ah	52	52
Cranking rating [at $-18^{\circ}\text{C}$ ( $0^{\circ}\text{F}$ )] A	490	520
Reserve capacity min.	123	118

### NOTES

1. CRANKING RATING is the current a battery can deliver for 30 seconds and maintain a terminal voltage of 7.2 volts or greater at a specified temperature.
2. RESERVE CAPACITY RATING is the amount of time a battery can deliver 25A and maintain a minimum terminal voltage of 10.5 at  $27^{\circ}\text{C}$  ( $80^{\circ}\text{F}$ ).

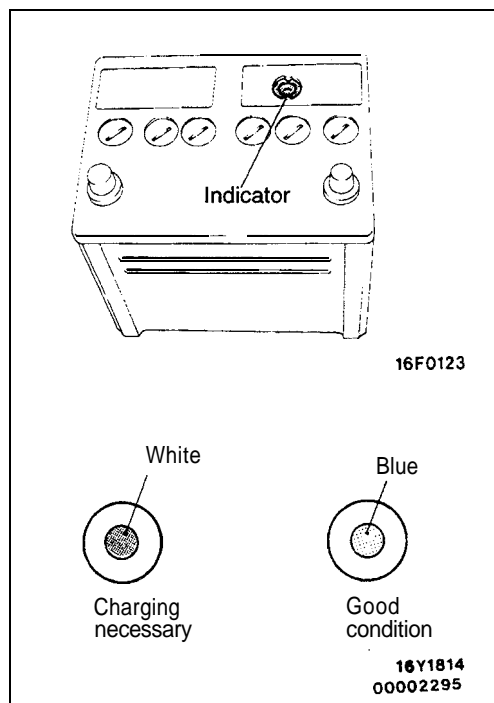

## ON-VEHICLE SERVICE

### BATTERY INSPECTION

#### BATTERY VISUAL CHECK (1)

The battery contains a visual test indicator which gives blue signal when an adequate charge level exists, and white signal when charging is required.

#### BATTERY VISUAL CHECK (2)

Make sure ignition switch is in Off position and all battery feed accessories are Off.

1. Disconnect ground cable from battery before disconnecting (+) cable.
2. Remove battery from vehicle.

#### Caution

**Care should be taken in the event battery case is cracked or leaking to protect hands from the electrolyte. A suitable pair of rubber gloves (not the household type) should be worn when removing battery by hand.**

3. Inspect battery carrier for damage caused by loss of acid from battery. If acid damage is present, it will be necessary to clean area with a solution of clean warm water and baking soda. Scrub area with a stiff bristle brush and wipe off with a cloth moistened with ammonia or baking soda in water.



4. Clean top of battery with same solutions as described in step (3).
5. Inspect battery case and cover for cracks. If cracks are present, battery must be replaced.
6. Clean the battery post with a suitable battery post cleaning tool.
7. Clean the inside surfaces of the terminal clamps with a suitable battery terminal cleaning tool. Replace damaged or frayed cables and broken terminal clamps.
8. Install the battery in vehicle.
9. Connect (+) and (-) cables to battery in the order of mention.
10. Tighten the clamp nut securely.

### BATTERY CHARGING

#### Caution

**When batteries are being charged, an explosive gas forms beneath the cover of each cell. Do not smoke near batteries on charge or which have recently been charged. Do not break live circuits at the terminals of the batteries on charge. A spark will occur where the live circuit is broken. Keep all open flames away from the battery.**

Battery electrolyte temperature may temporarily be allowed to rise to 55°C (131°F). Increase of electrolyte temperature above 55°C (131 °F) is harmful to the battery, causing deformation of battery cell, decrease in life of battery, etc.

#### CHARGE RATE

If the test indicator is white, the battery should be charged as outlined below.

When the dot appears or when maximum charge shown below is reached, charging should be stopped.

#### NOTE

When the charging is performed at 5 amps, charging is virtually 100% three hours after the indicator's indication changes from white to green.

Use fast charging only in an emergency.

If the indicator does not turn to green even after the battery is charged, the battery should be replaced; do not overcharge.

#### Charge Rate Chart

Battery	Slow Charging		Fast Charging	
	5 amps 15 hrs.	10 amps 7.5 hrs	20 amps 3.75 hrs	30 amps 2.5 hrs.
75D26R-MF (490 amps)				
75D23R-MF (520 amps)				

**BATTERY TESTING PROCEDURE**

**TEST STEP**

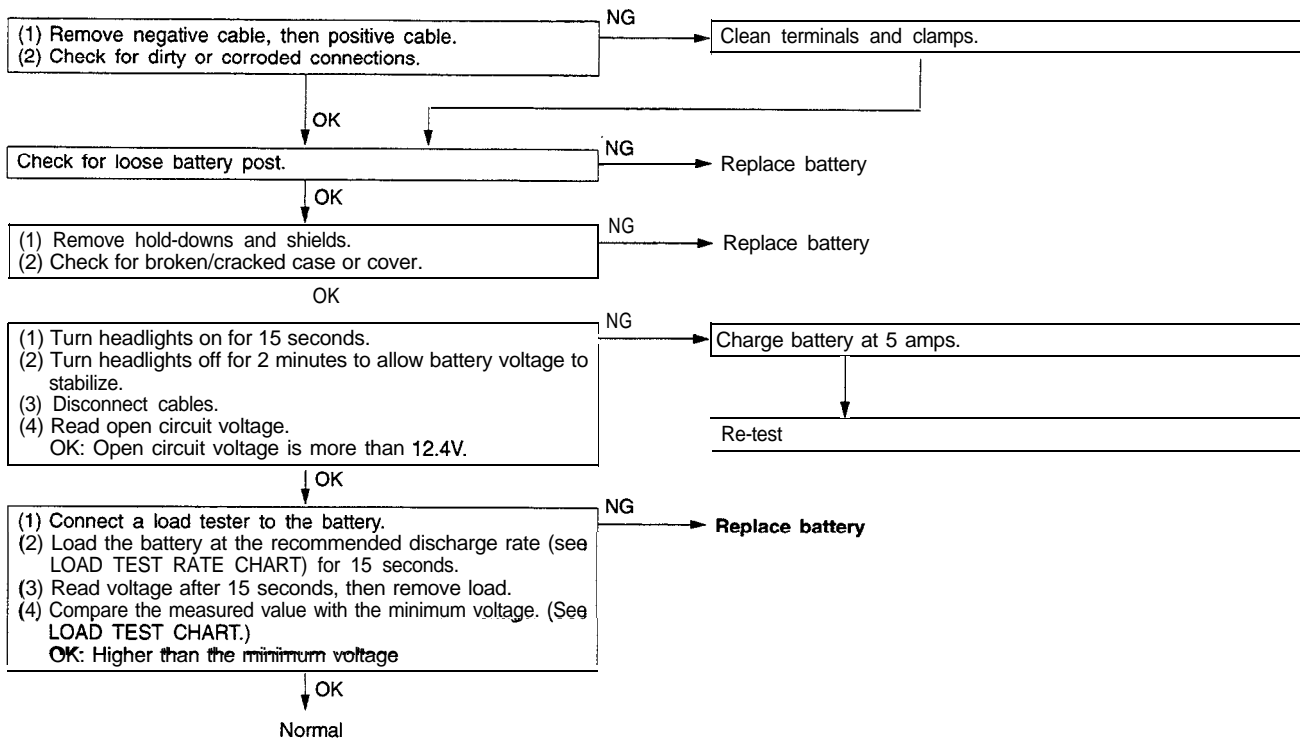

**LOAD TEST CHART**

Temperature °C (°F)	21 (70) and above	16 (60)	10 (50)	4 (40)	-1 (30)	-7 (20)	-12 (10)	-18 (0)
Minimum voltage	9.6	9.5	9.4	9.3	9.1	8.9	8.7	8.5

**LOAD TEST RATE CHART**

Load test (Amps)	Cranking rating (0°F)	Reserve capacity	Application
240 amps	490 amps	123 minutes	75D26R-MF
240 amps	520 amps	123 minutes	75D23R-MF

# IGNITION SWITCH

## SPECIAL TOOL

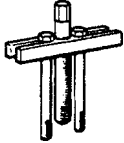
Tool	Tool number and name	Supersession	Application
	MB990803 Steering wheel puller	General service tool	Removal of steering wheel

# IGNITION SWITCH

## REMOVAL AND INSTALLATION

**CAUTION: SRS**

Before removal of air bag module, refer to GROUP 52B – Service Precautions and Air Bag Module and Clock Spring.

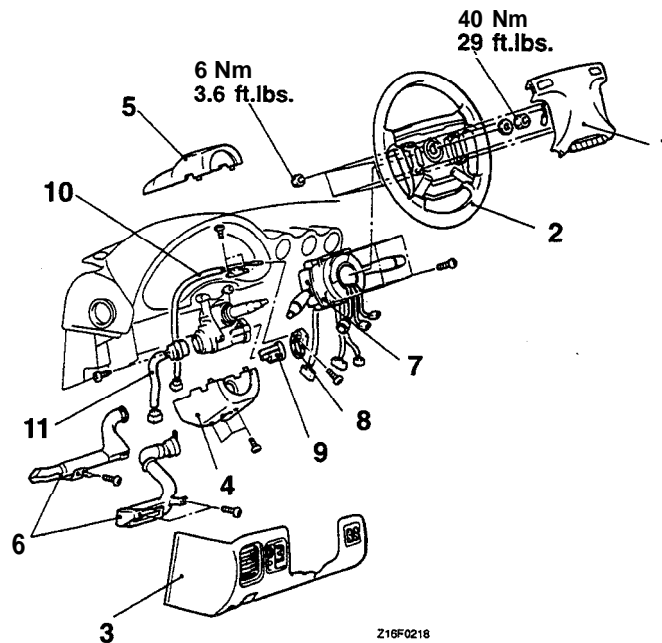

Z16F0218

### Steering lock cylinder removal steps

1. Air bag module (Refer to GROUP 52B – Air Bag Module and Clock Spring.)
2. Steering wheel
3. Knee protector (Refer to GROUP 52A – Instrument Panel.)
4. Column cover, lower
5. Column cover, upper
6. Lap cooler duct and foot shower duct
7. Column switch and clock spring assembly
8. Ignition key illumination ring
9. Steering lock cylinder

### Ignition switch segment removal steps

3. Knee protector (Refer to GROUP 52A – Instrument Panel.)
4. Column cover, lower
5. Column cover, upper
6. Lap cooler duct and foot shower duct
10. Key reminder switch segment
11. Ignition switch segment

TSB Revision

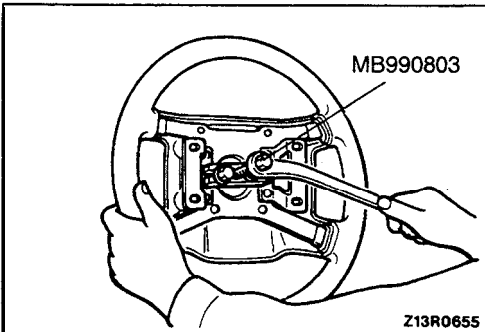
**REMOVAL SERVICE POINTS****◀A▶ STEERING WHEEL REMOVAL**

Remove the steering wheel by using the special tool.

**Caution**

Do not hammer on the steering wheel to remove it; doing so may damage the collapsible mechanism.

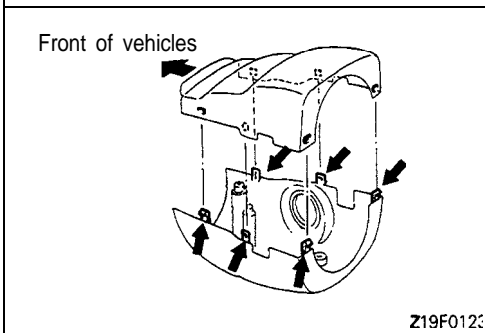
**◀B▶ COLUMN COVER LOWER / COLUMN COVER UPPER REMOVAL**

After the screws have been removed, remove the covers, while making sure not to break the grippers.

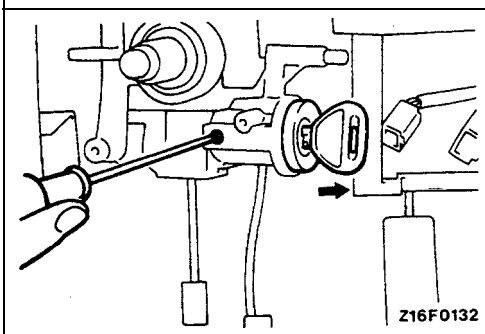
**◀C▶ STEERING LOCK CYLINDER REMOVAL**

- (1) Insert the ignition key into the steering lock cylinder and place the key in the ACC position.
- (2) Press the lock pin down with a Phillips head screwdriver (small-size one) to remove the steering lock cylinder.

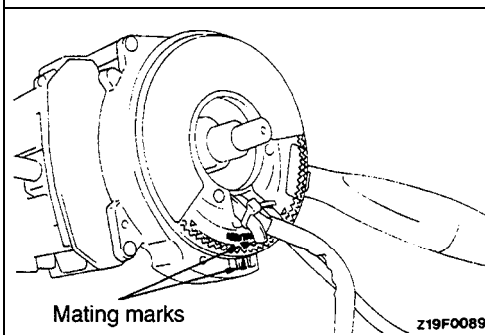
**INSTALLATION SERVICE POINT****▶A◀ COLUMN SWITCH AND CLOCK SPRING ASSEMBLY INSTALLATION**

Line up the "NEUTRAL" mark of the clock spring with the mating mark to center the clock spring.

**Caution**

If the clock spring is not centered, problems such as intermediate failure of the steering wheel to turn, broken ribbon cable in the clock spring, or the like could occur. As a result, they might hinder proper operation of the SRS, resulting in serious injury.

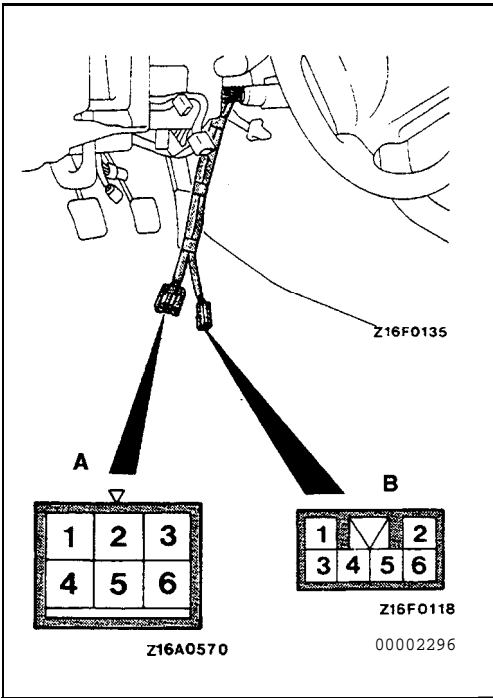

**INSPECTION**

**IGNITION SWITCH CHECK**

- (1) Remove the knee protector, the column cover lower and the column cover upper. (Refer to GROUP 52A – Instrument Panel.)
- (2) Disconnect the wiring connector from the ignition switch and key reminder switch, and connect an ohmmeter to the switch side connector.
- (3) Operate the switch, and check the continuity between the terminals.

Position	Key	Connector A						Connector B				Connector B				
		Ignition switch terminal No.						Key reminder switch terminal No.				Ignition key illumination light terminal No.				
		1	2	3	4	5	6	1	2	3	6	4	5			
LOCK	Removed									○	○					
ACC	Installed			○	○	○										
ON				○	○	○	○		○	○						
START			○	○	○	○	○									

# METERS AND GAUGES

## SPECIFICATIONS

### GENERAL SPECIFICATIONS

#### METERS AND GAUGES

Items		Specifications
Speedometer	Type	Mechanical type* <sup>1</sup> Electrical type* <sup>2</sup>
Tachometer	Type	Pulse type
Fuel gauge	Type	Coil type
Fuel gauge unit	Type	Variable resistance type
Engine coolant temperature gauge	Type	Coil type
Engine coolant temperature gauge unit	Type	Thermistor type
Oil pressure gauge	Type	Bi-metal type
Oil pressure gauge unit	Type	Bi-metal type
Pressure gauge <Turbo>	Type	Moving coil type
Voltage gauge <Non-turbo>	Type	Moving iron type

#### NOTE

\*<sup>1</sup> 1992 models

\*<sup>2</sup> 1992 models <Turbo>, and from 1993 models

## INDICATORS AND WARNING LIGHTS

Items	Specifications
Turn signal indicator light W	3.0
High beam indicator light W	1.4 (74)
Charging system warning light W	1.4 (74)
Oil pressure warning light W	1.4 (74)
Door-ajar warning light W	1.4 (74)
Brake warning light W	1.4 (74)
Low fuel warning light W	3.4 (158)
Seat belt warning light W	1.4 (74)
Cruise control indicator light W	1.4 (74)
Engine coolant level warning light W	1.4 (74)
Check engine warning light W	1.4 (74)
Security indicator light* <sup>1</sup> W	1.4 (74)
Power/economy changeover indicator light <A/T> W	1.12
Overdrive indicator light <A/T> W	1.12
Supplemental restraint system warning light W	1.4 (74) × 2
Anti-lock braking system warning light W	1.4 (74)
Active aero system warning indicator light <AWD> W	1.4 (74)
Washer fluid level indicator light W	1.4 (74)
4-wheel steering oil level warning light <AWD> W	1.4 (74)
Cruise control ON indicator light W	1.4 (74)
Tour/sport mode indicator light* <sup>2</sup> W	1.12
Tour mode indicator light* <sup>3</sup> W	1.12

## NOTE

- (1) The values in parentheses denote SAE trade numbers.
- (2) The \*<sup>1</sup> symbol indicates vehicles with theft-alarm system.
- (3) The ● 2 symbol indicates vehicles with Electronic Controlled Suspension.
- (4) The \*<sup>3</sup> symbol indicates vehicles with Active Exhaust System.

**SERVICE SPECIFICATIONS**

Items	Standard values	
Speedometer indication error mph	20	19-22
	40	38-44
	60	57-66
	80	76-88
	100	94-110
Tachometer indication error rpm	1,000	± 100
	3,000	± 150
	5,000	± 250
	6,000	± 300
Fuel gauge unit resistance Ω	Point F	3 ± 2
	Point E	110 ± 7
Fuel gauge unit float height mm (in.)	Point F	18.6-21.6 (.73-.85)
	Point E	193.4-196.4 (7.61-7.73)
Engine coolant temperature gauge unit resistance [at 70°C (158°F)] Ω		104 ± 13.5
Fuel gauge resistance Ω	Between A – B	Approx. 254
	Between A – C	Approx. 101
	Between B – C	Approx. 153
Engine coolant temperature gauge resistance Ω	Between A – B	Approx. 51
	Between A – C	Approx. 139
	Between B – C	Approx. 190
Oil pressure gauge resistance Ω		Approx. 42
Pressure gauge resistance <Turbo> Ω		Approx. 72

**SEALANT**

Items	Specified sealant	Type
Engine coolant temperature gauge unit	3M Nut Locking Part No. 4171 or equivalent	Semi-drying sealant



TROUBLESHOOTING

METERS AND GAUGES CIRCUIT DIAGRAM <UP TO 1993 MODELS>

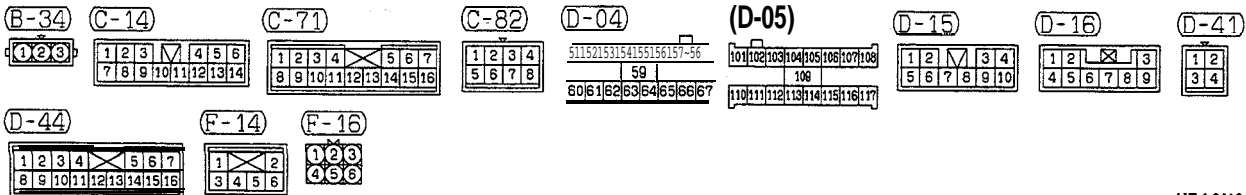
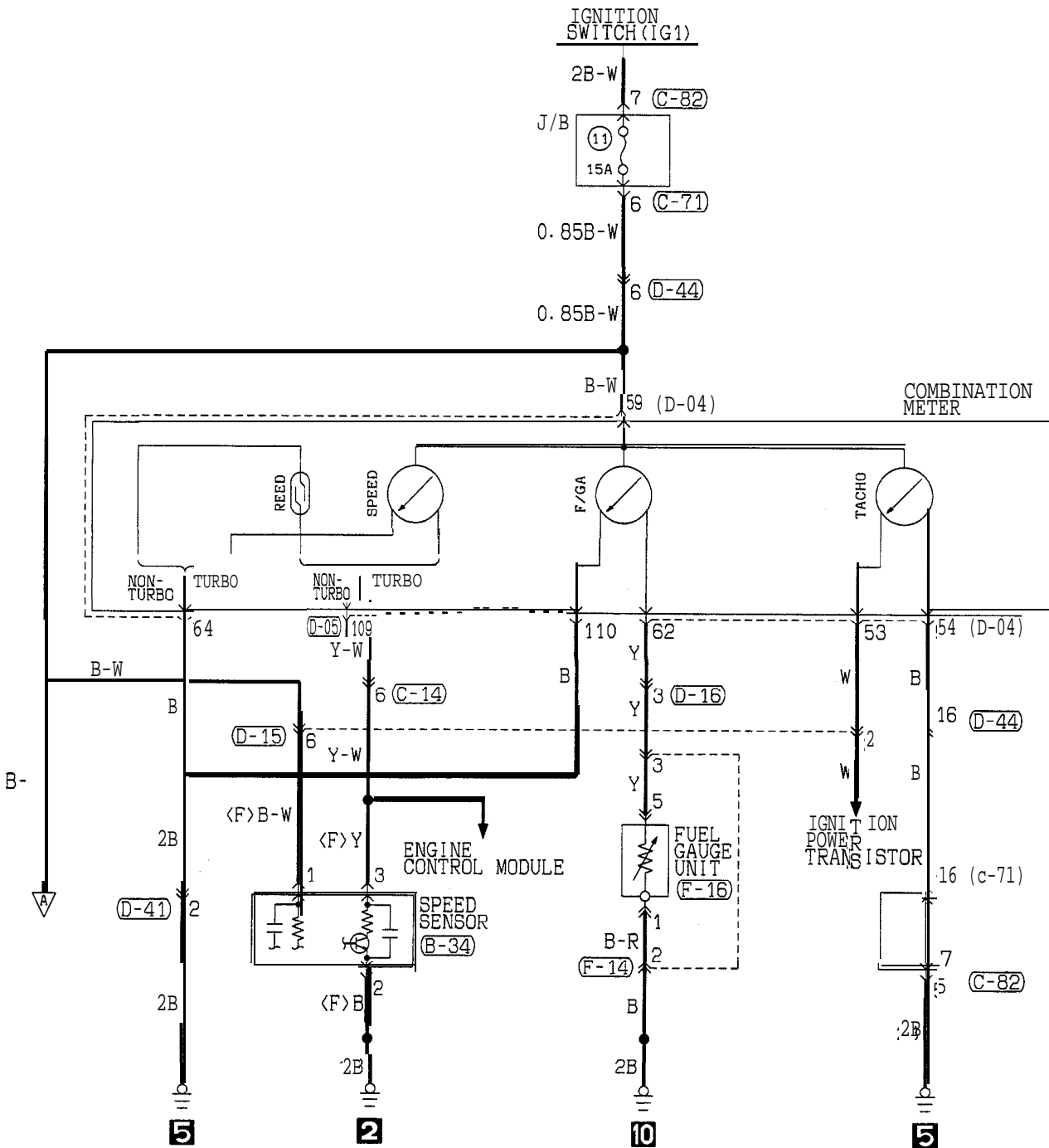

TSB Revision

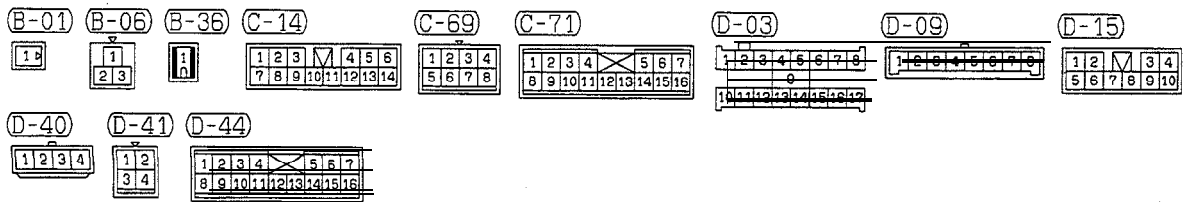
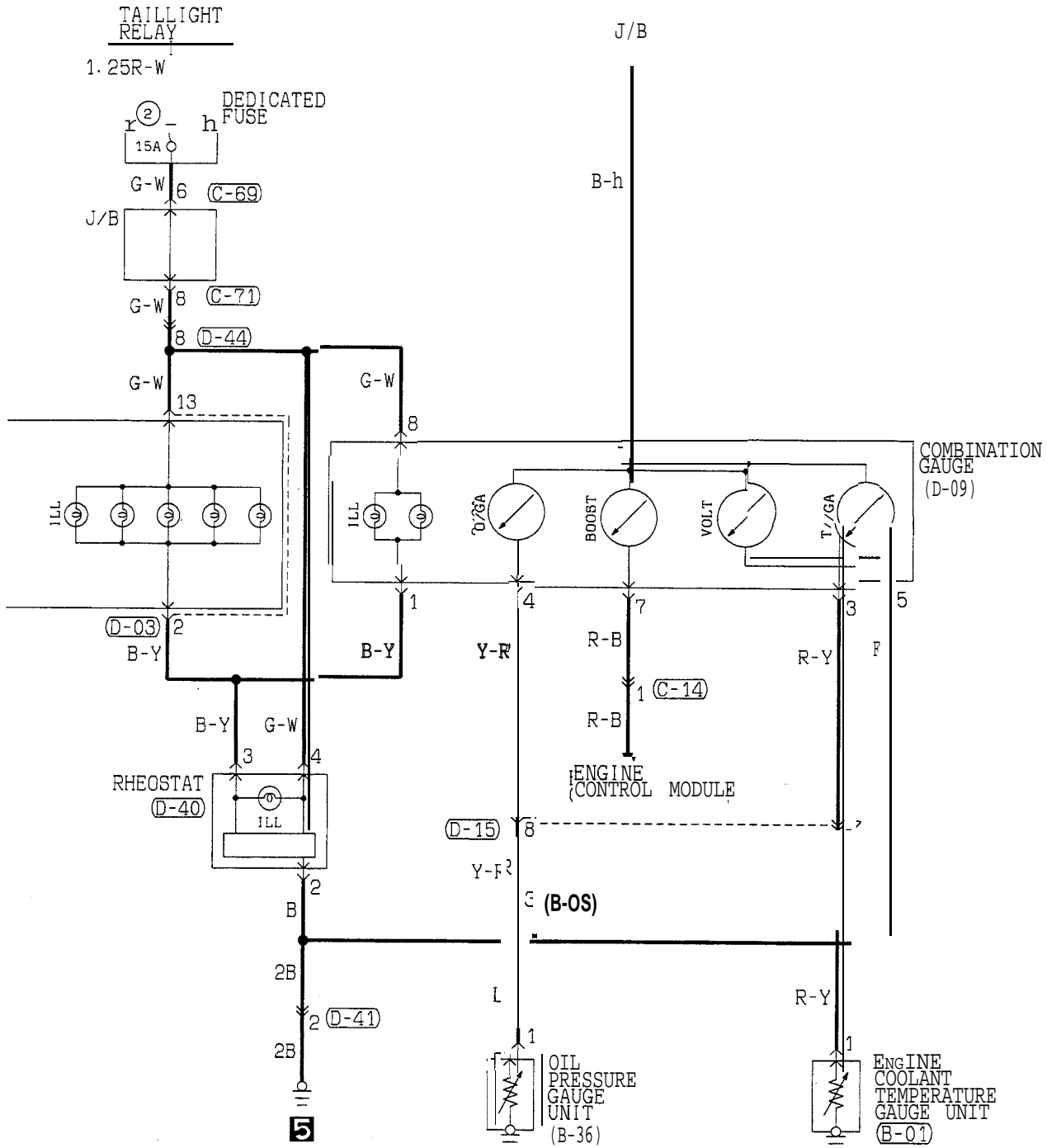

HR10M00AB

TSB Revision

METERS AND GAUGES CIRCUIT DIAGRAM <1994 MODELS>

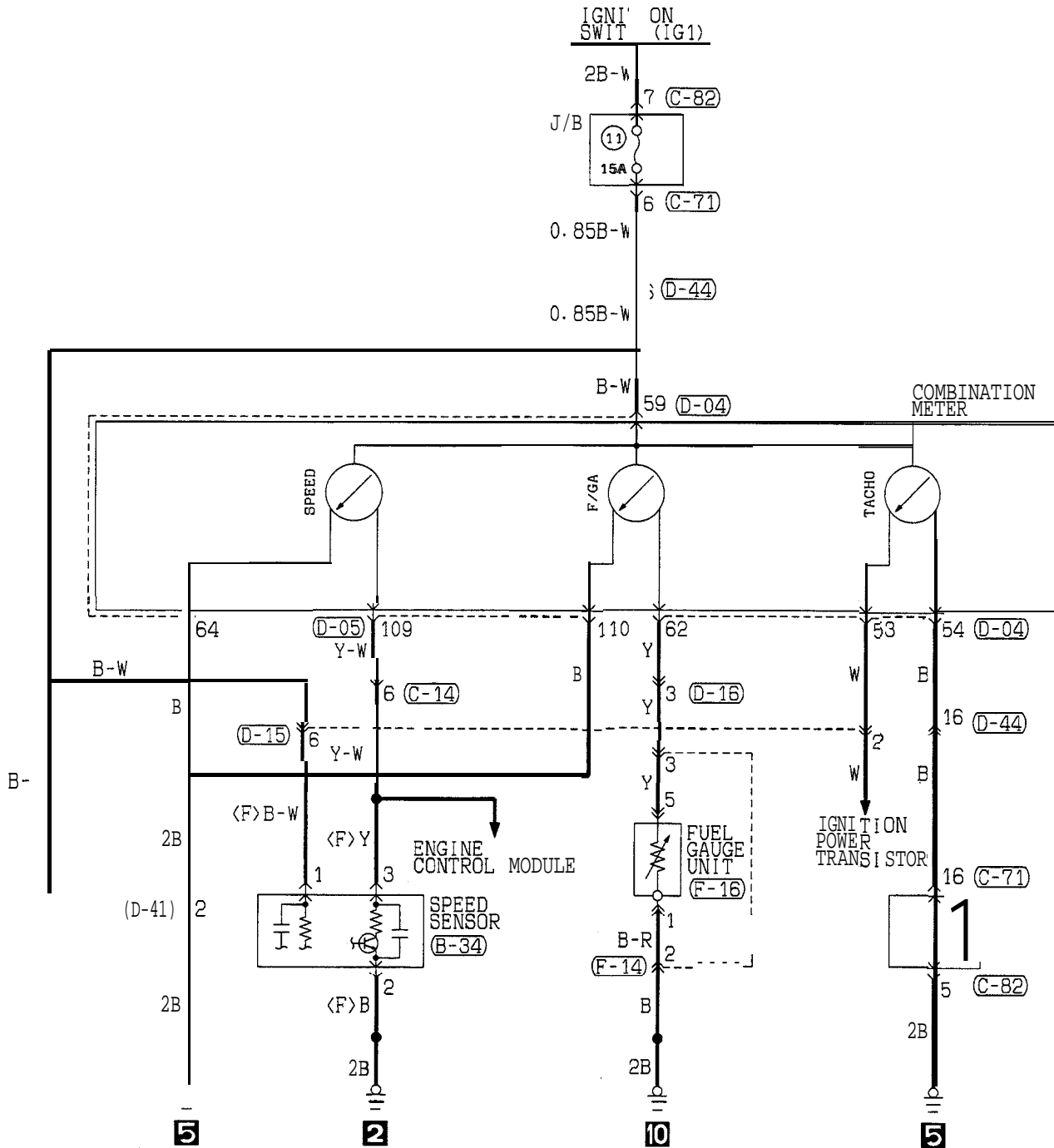

<b>(B-34)</b> 1 2 3 4 5 6 7 8 9 10 11 12 13 14	<b>(C-14)</b> 1 2 3 4 5 6 7 8 9 10 11 12 13 14 15 16	<b>(C-71)</b> 1 2 3 4 5 6 7 8 9 10 11 12 13 14 15 16	<b>(C-82)</b> 1 2 3 4 5 6 7 8	<b>(D-04)</b> 5 1 5 2 5 3 5 4 5 5 5 6 5 7 5 8 59 6 0 6 1 6 2 6 3 6 4 6 5 6 6 6 7	<b>(D-05)</b> 1 0 1 1 0 2 1 0 3 1 0 4 1 0 5 1 0 6 1 0 7 1 0 8 1 0 9 1 1 0 1 1 1 1 1 2 1 1 3 1 1 4 1 1 5 1 1 6 1 1 7	<b>(D-15)</b> 1 2 3 4 5 6 7 8 9 10	<b>(D-16)</b> 1 2 3 4 5 6 7 8 9	<b>(D-41)</b> 1 2 3 4	
<b>(D-44)</b> 1 2 3 4 5 6 7 8 9 10 11 12 13 14 15 16	<b>(F-14)</b> 1 2 3 4 5 6	<b>(F-16)</b> 1 2 3 4 5 6							

TSB Revision

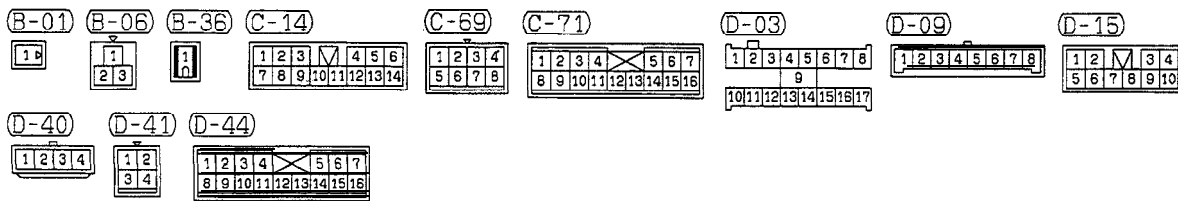
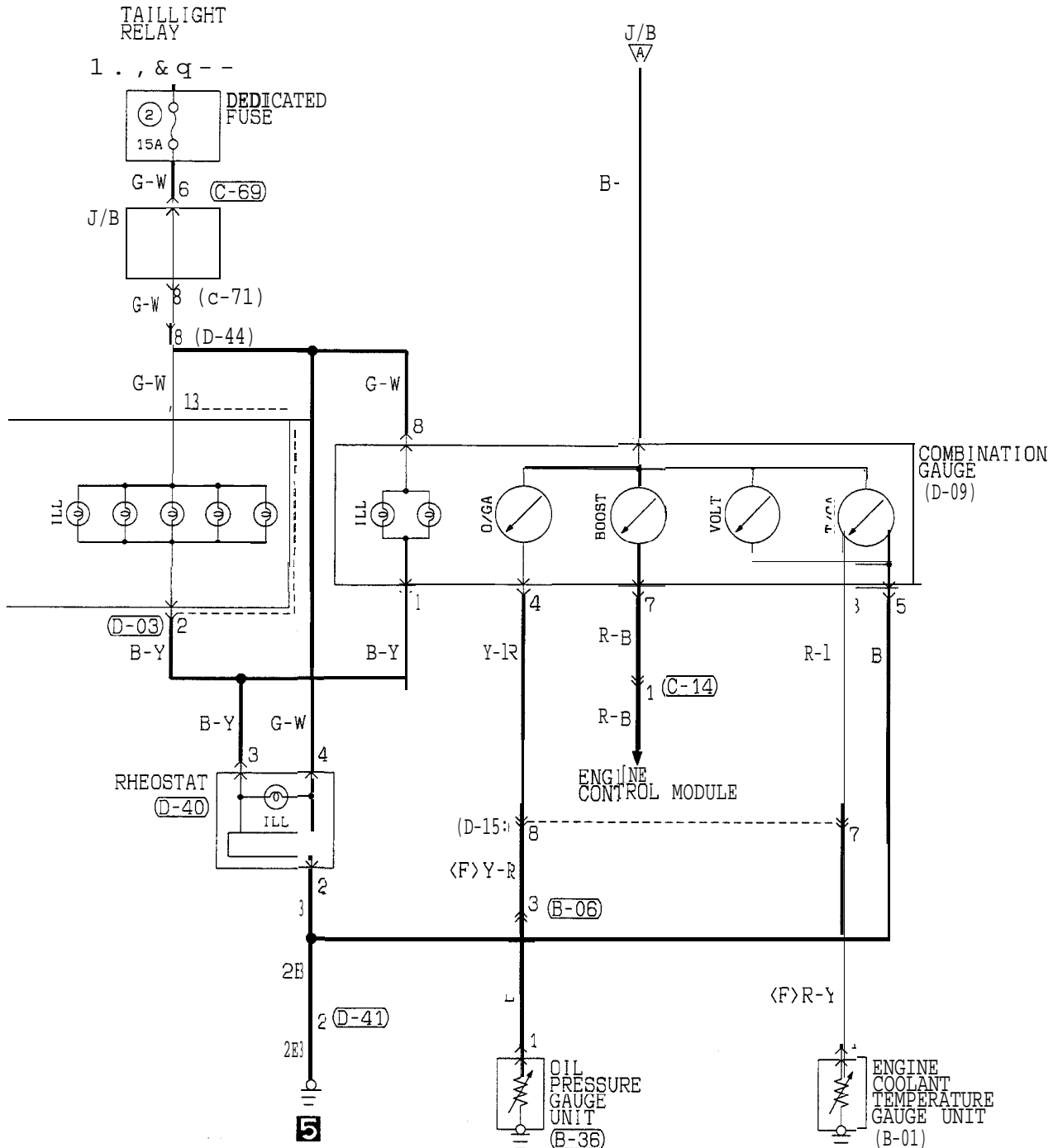

TSB Revision

METERS AND GAUGES CIRCUIT DIAGRAM <FROM 1995 MODELS>

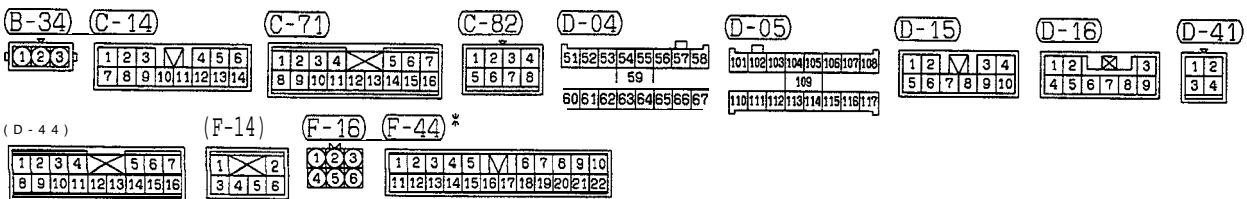
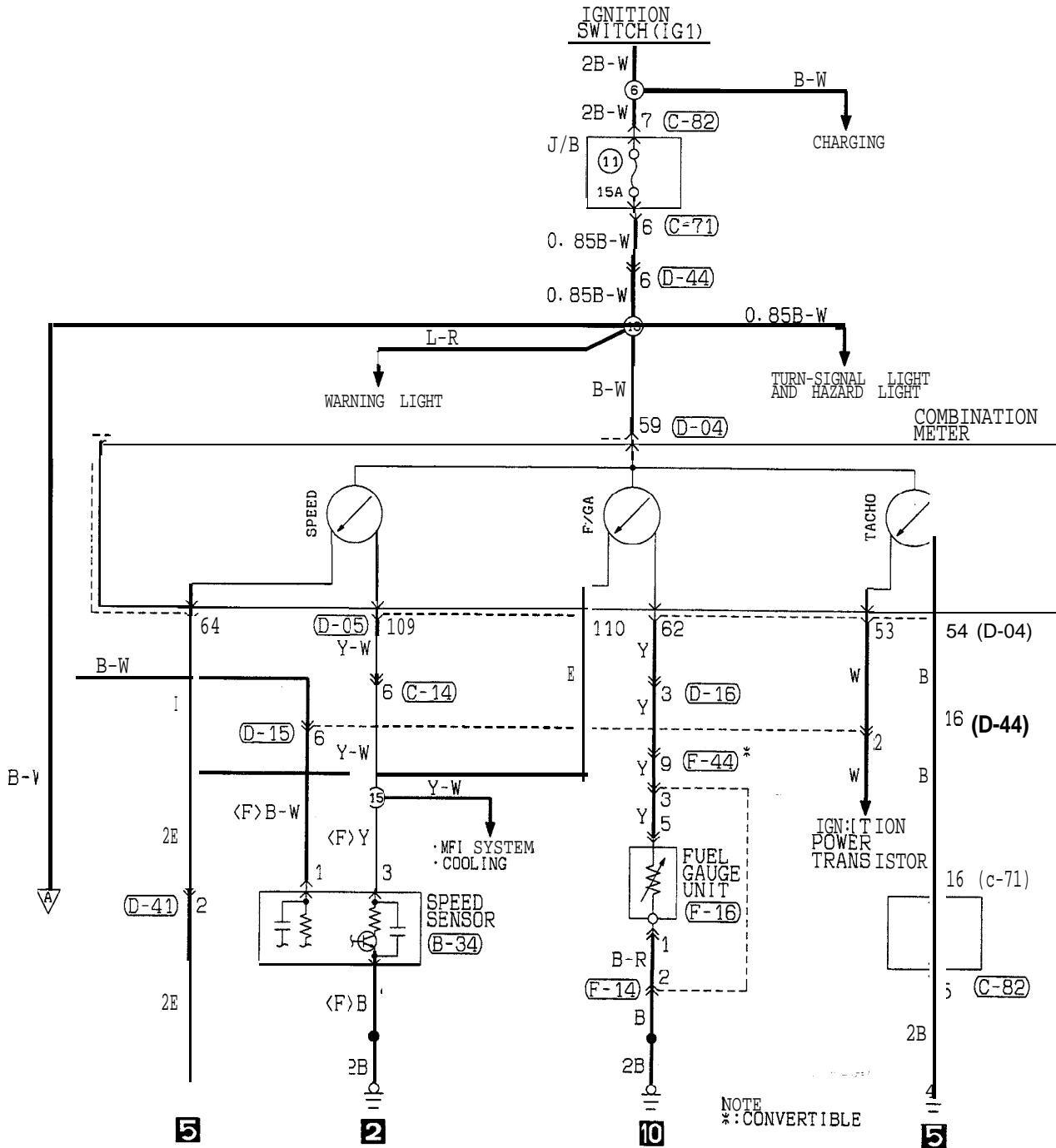

TSB Revision

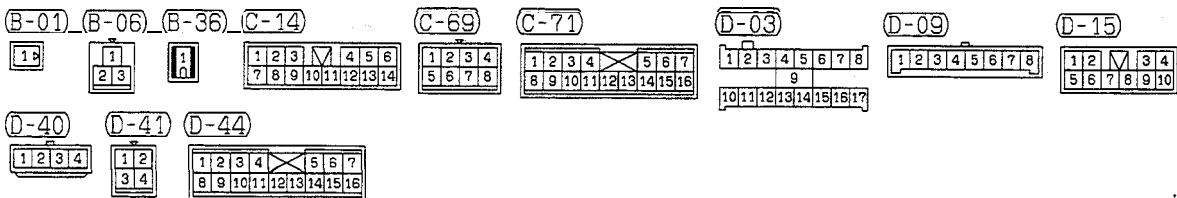
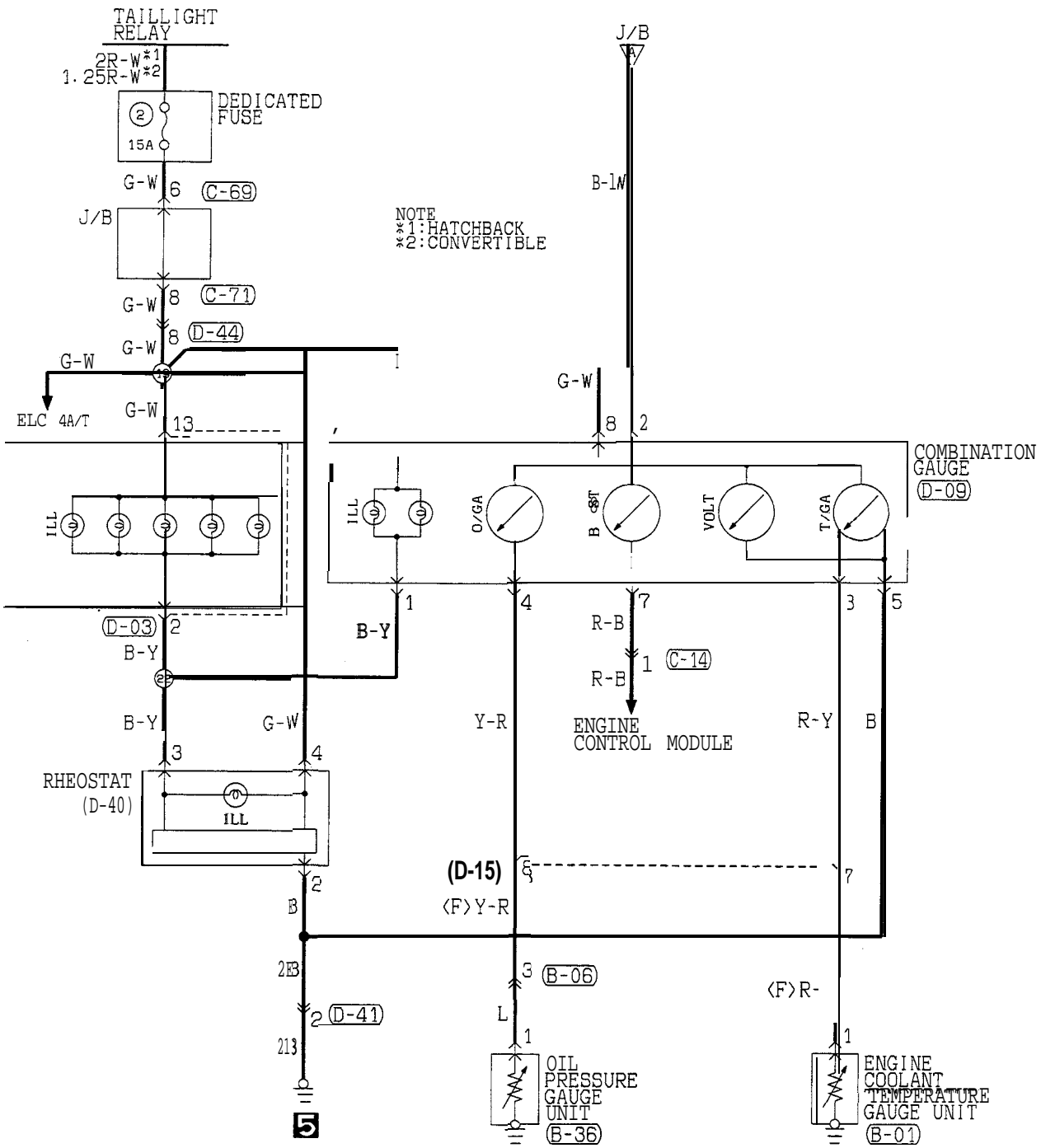

HR10M02AB

TSB Revision

**OPERATION****<Fuel gauge>**

- When the ignition key is at the “ON” position, the fuel gauge is activated.
- When there is much fuel, the unit’s resistance is small and the current flowing in the circuit is great, so the gauge’s indicator indicates in the “F” area.
- When there is little fuel, the unit’s resistance is high and the current flowing in the circuit is small, so the gauge’s indicator indicates in the “E” area.

**<Engine coolant temperature gauge>**

- When the ignition key is at the “ON” position, the engine coolant temperature gauge is activated.
- When the engine coolant temperature is high, the unit’s resistance is low and there is a great flow of current in the circuit, so the gauge’s indicator indicates in the “H” area.
- When the engine coolant temperature is low, the unit’s resistance is high and there is a small flow of current in the circuit, so the gauge’s indicator indicates in the “C” area.

**<Reed switch (mechanical speedometer type) /Speed sensor (electrical speedometer type)>**

- Pulses are produced in accordance with the vehicle speed, and vehicle-speed signals are input to systems (the MFI system, etc.) that regulate according to the vehicle speed.

**TROUBLESHOOTING HINTS**

1. The fuel gauge doesn’t function, or shows the incorrect indication.
  - (1) Disconnect the connector of the fuel pump and gauge unit assembly; the “F” side is indicated when terminal (5) is then grounded.
    - Check the fuel gauge.
2. The engine coolant temperature gauge doesn’t function, or shows the incorrect indication.
  - (1) The “H” side is indicated when the connector of the engine coolant temperature gauge unit is disconnected and then grounded.
    - Check the engine coolant temperature gauge unit.
3. Systems dependent upon control according to the vehicle speed do not function correctly.
  - Check the reed switch (mechanical speedometer type)
  - Check the speed sensor (electrical speedometer type)
4. The oil pressure gauge doesn’t function, or shows the incorrect indication.
  - (1) The “H” side is indicated when the connector of the oil pressure gauge unit is disconnected and then grounded.
    - Check the oil pressure gauge unit.
5. The meter illumination light does not illuminate.
  - (1) The tail lights illuminate.
    - Check the rheostat.
6. The voltage gauge doesn’t function, or shows the incorrect indication.
  - Check the voltage gauge.

**<Oil pressure gauge>**

- When the ignition key is at the “ON” position, the oil pressure gauge is activated.
- When oil pressure is high, the internal contacts of the gauge unit are kept closed for a longer period of time. This causes more current to flow in the circuit, and the gauge pointer swings to the high pressure side.
- When oil pressure is low, the internal contacts of the gauge unit open in a shorter period of time. Therefore, there is less current flowing in the circuit and the gauge pointer swings to the low pressure side.

**<Pressure gauge (TURBO)>**

- When the ignition key is set to the “ON” position, the gauge indicator will be at “0”.
- When the engine is started, the indicator will move from “0” to the minus (–) side, and then, as the boost level increases, it will move to the plus (+) side.

**<Voltage gauge (NON-TURBO)>**

- When the ignition key is placed in the “ON” position, the voltage gauge operates and indicates a battery voltage of approximately 12 V.
- When the engine is started, the voltage gauge indicates a battery voltage of 12 to 16 V, indicating that the battery is on charge.

COMPONENT LOCATION

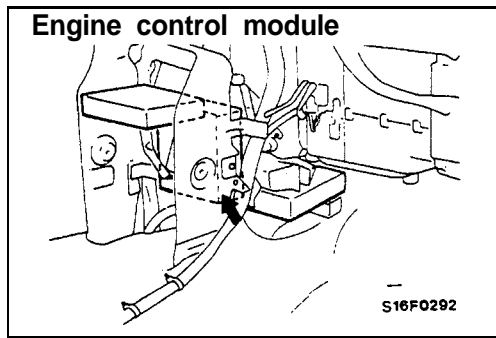



WARNING LIGHT CIRCUIT DIAGRAM <UP TO 1994 MODELS>

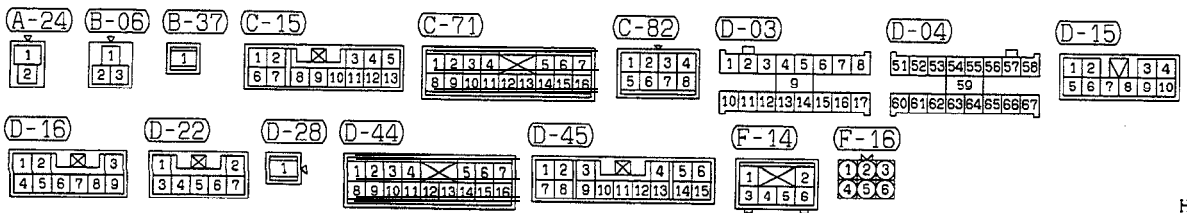
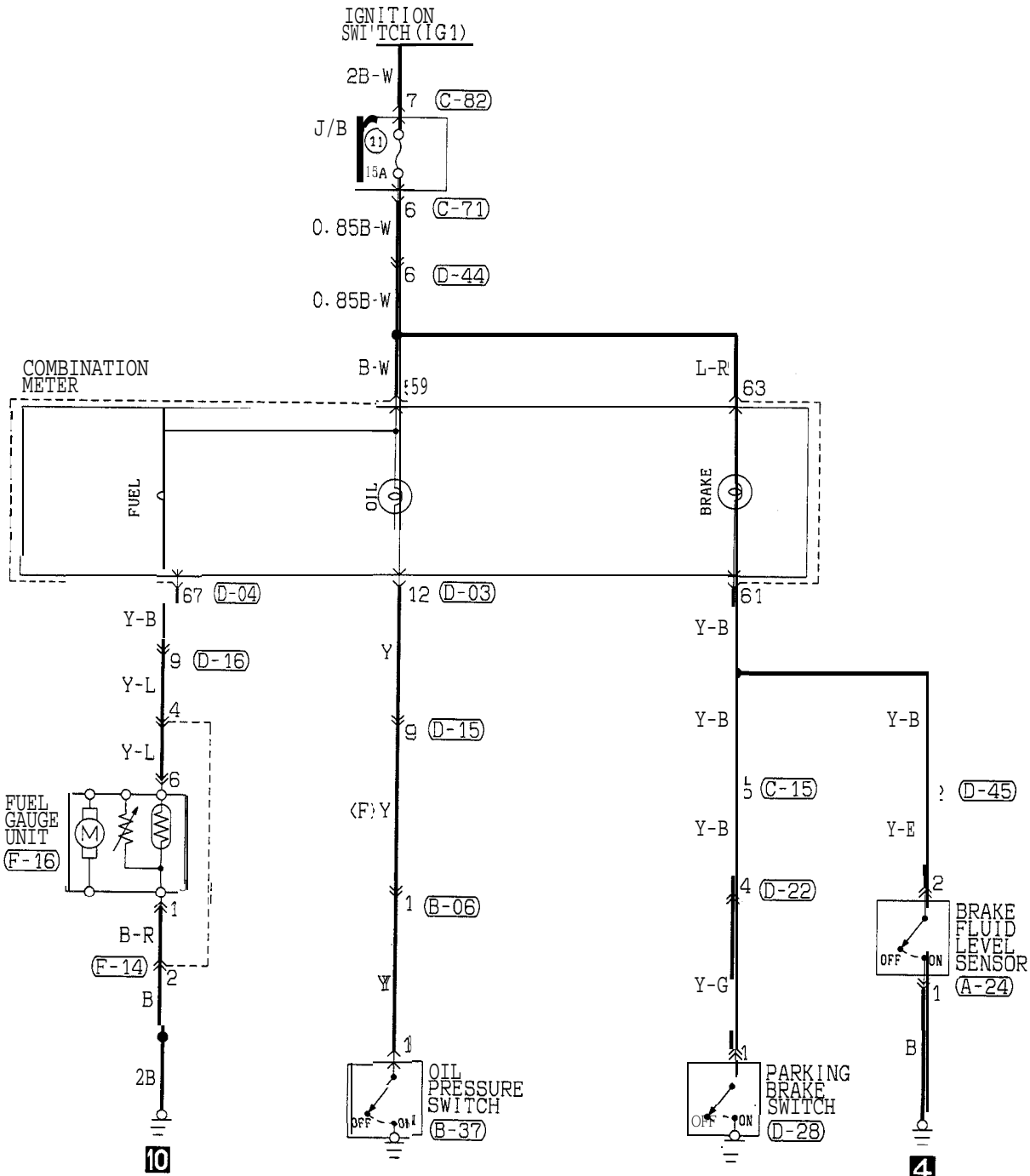

TSB Revision

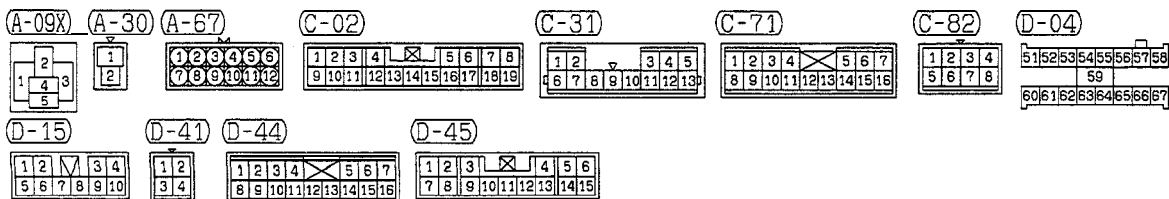
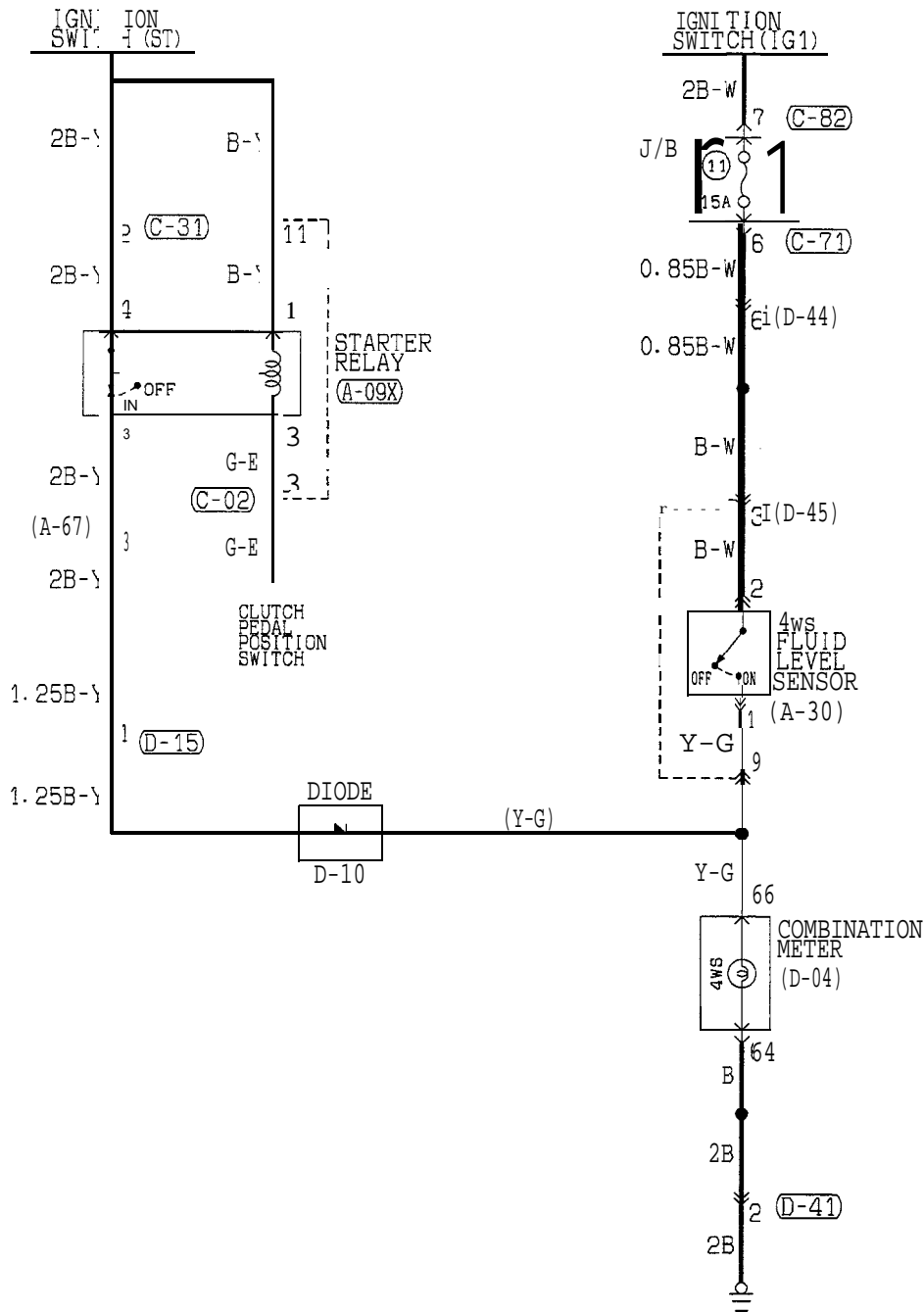

TSB Revision

WARNING LIGHT CIRCUIT DIAGRAM <1995 MODELS>

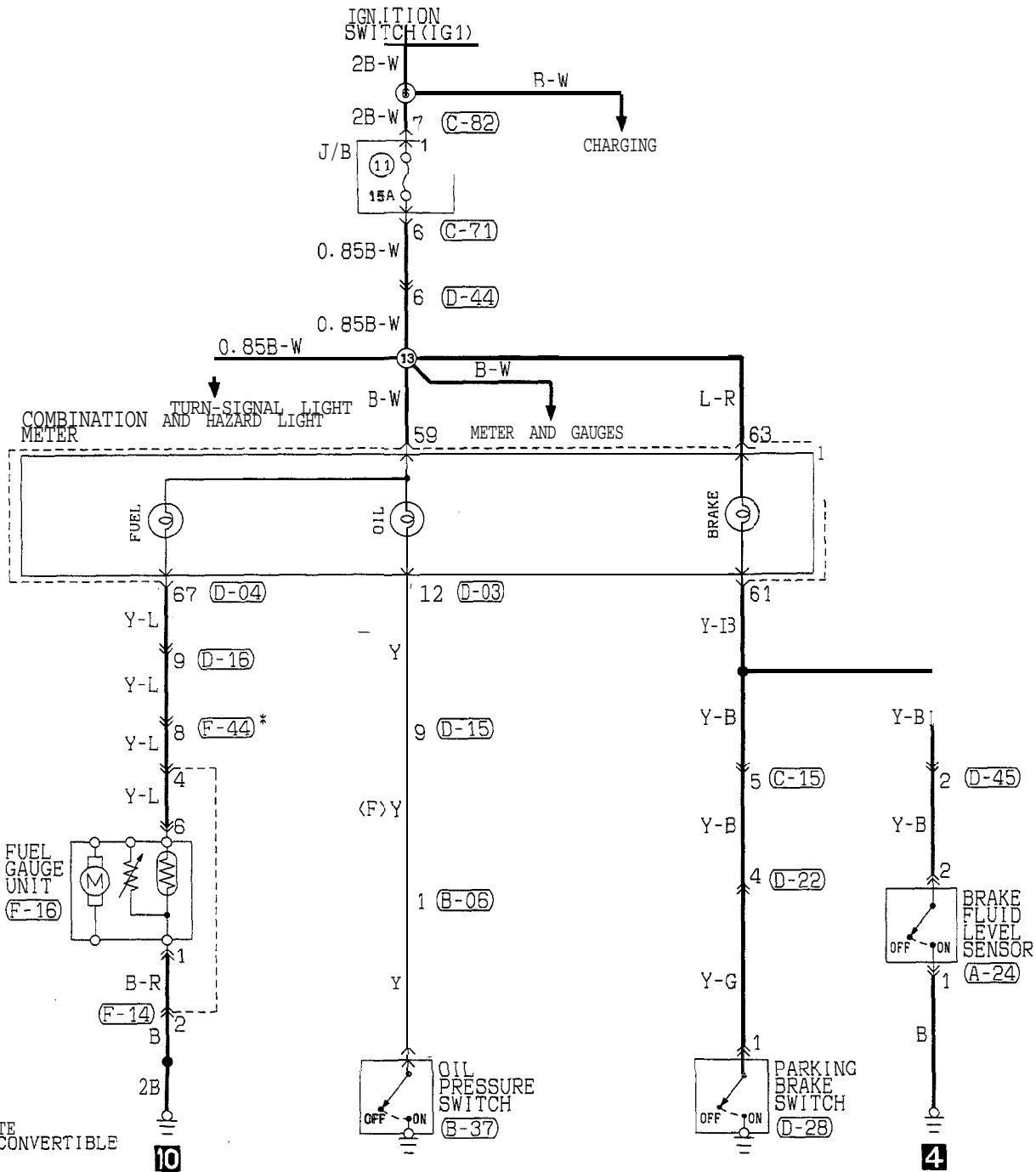

NOTE  
\* : CONVERTIBLE

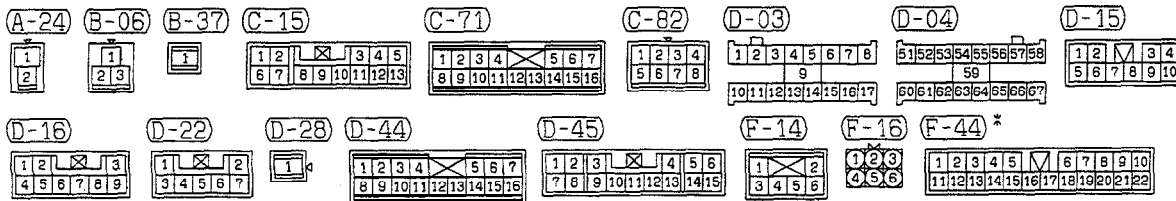

HR10M04AA

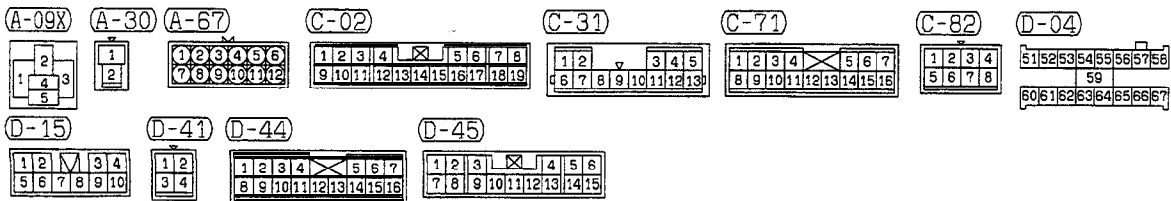
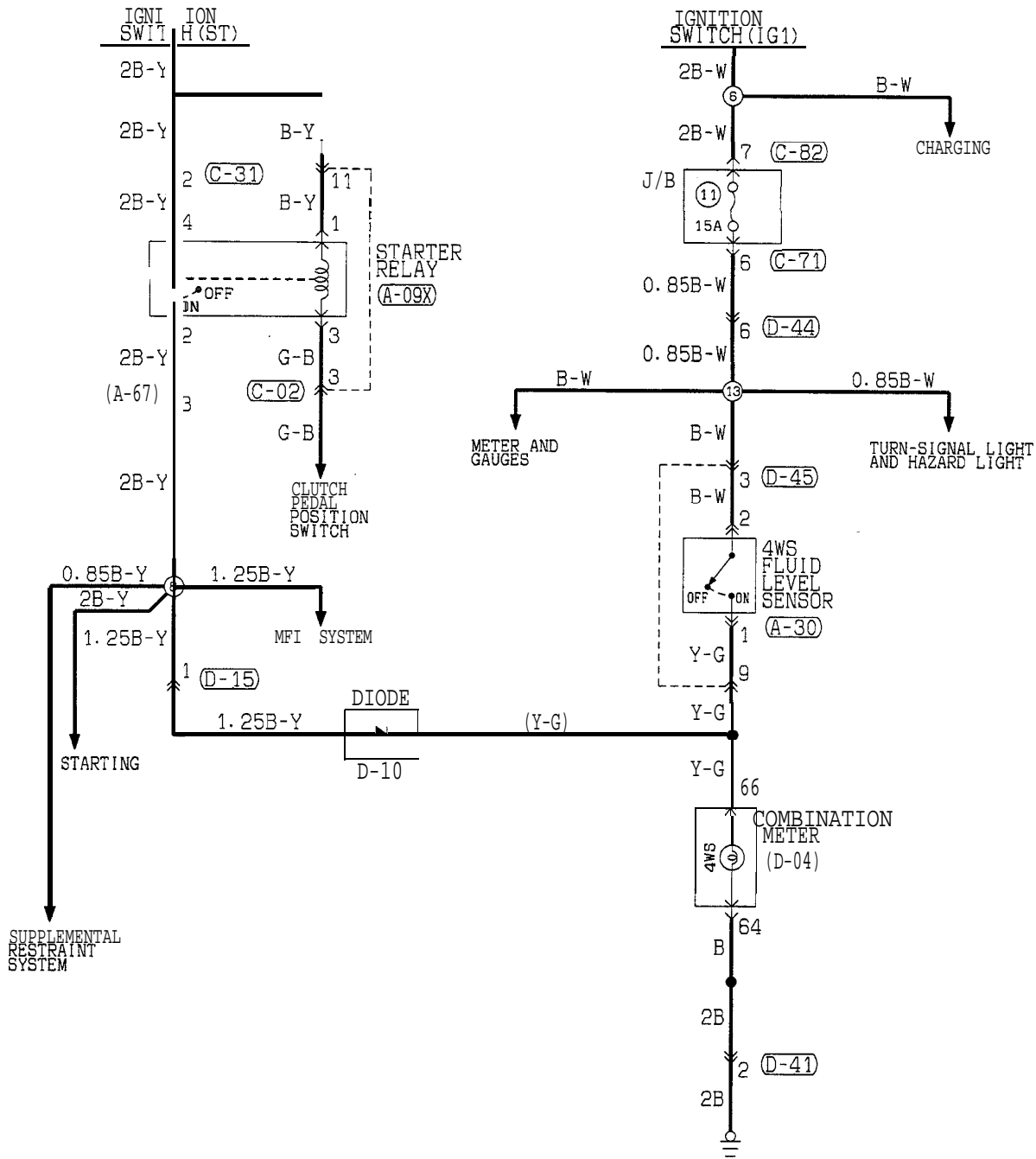

TSB Revision

WARNING LIGHT CIRCUIT DIAGRAM <FROM 1996 MODELS>

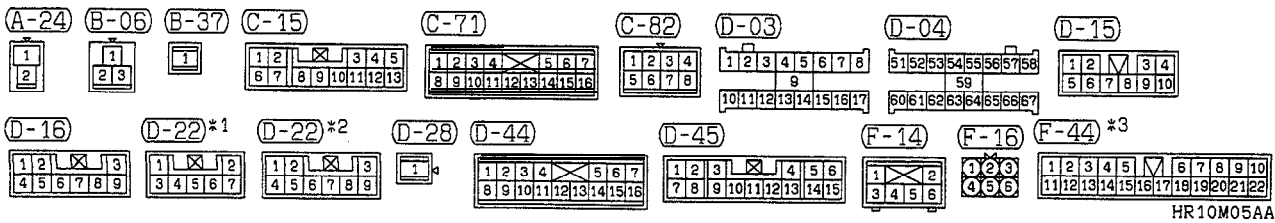
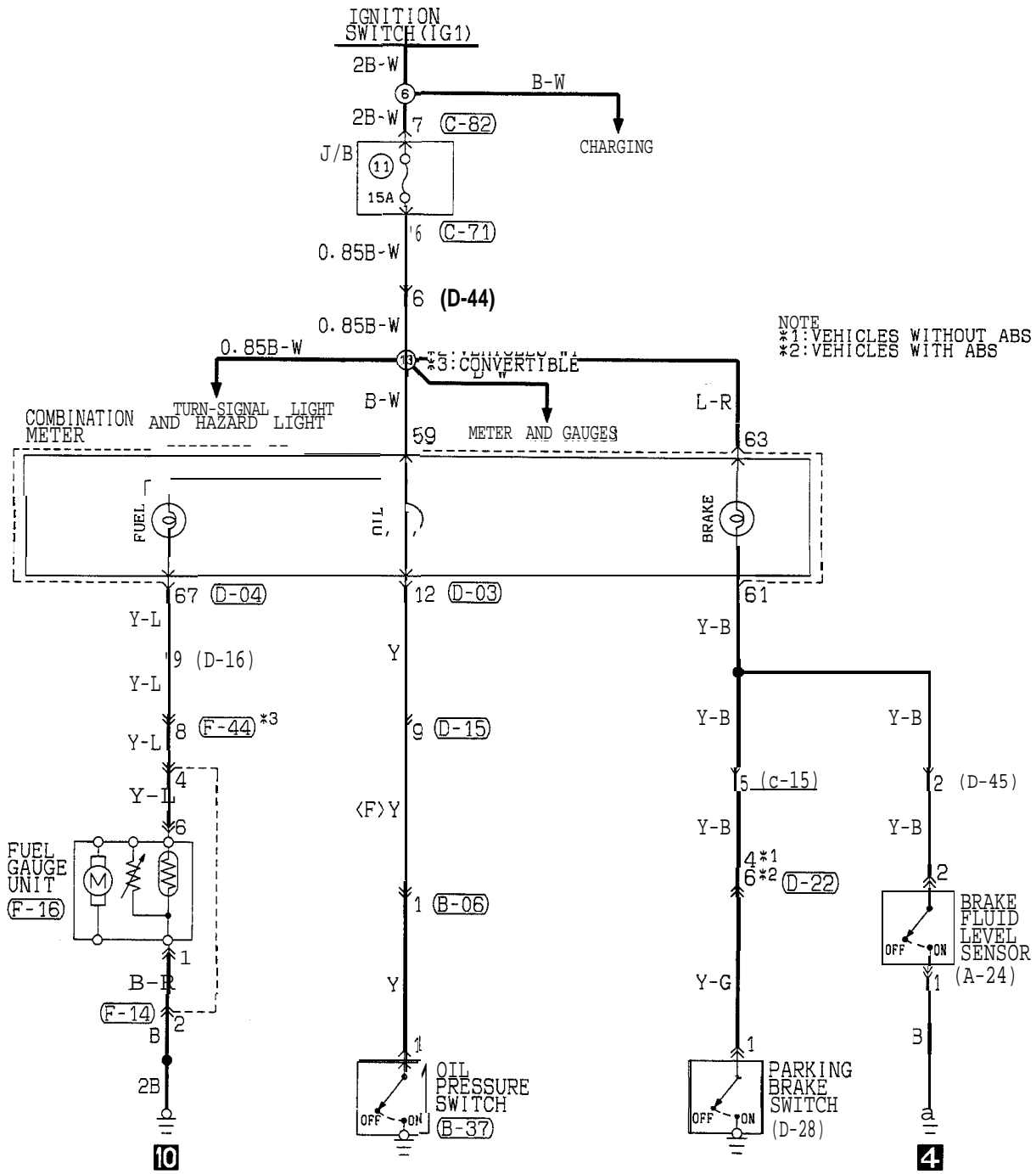

TSB Revision

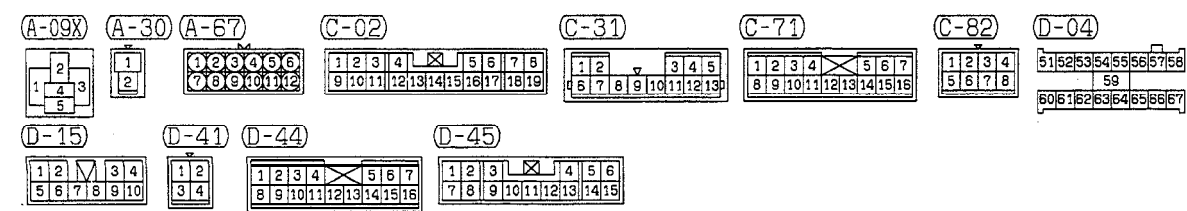
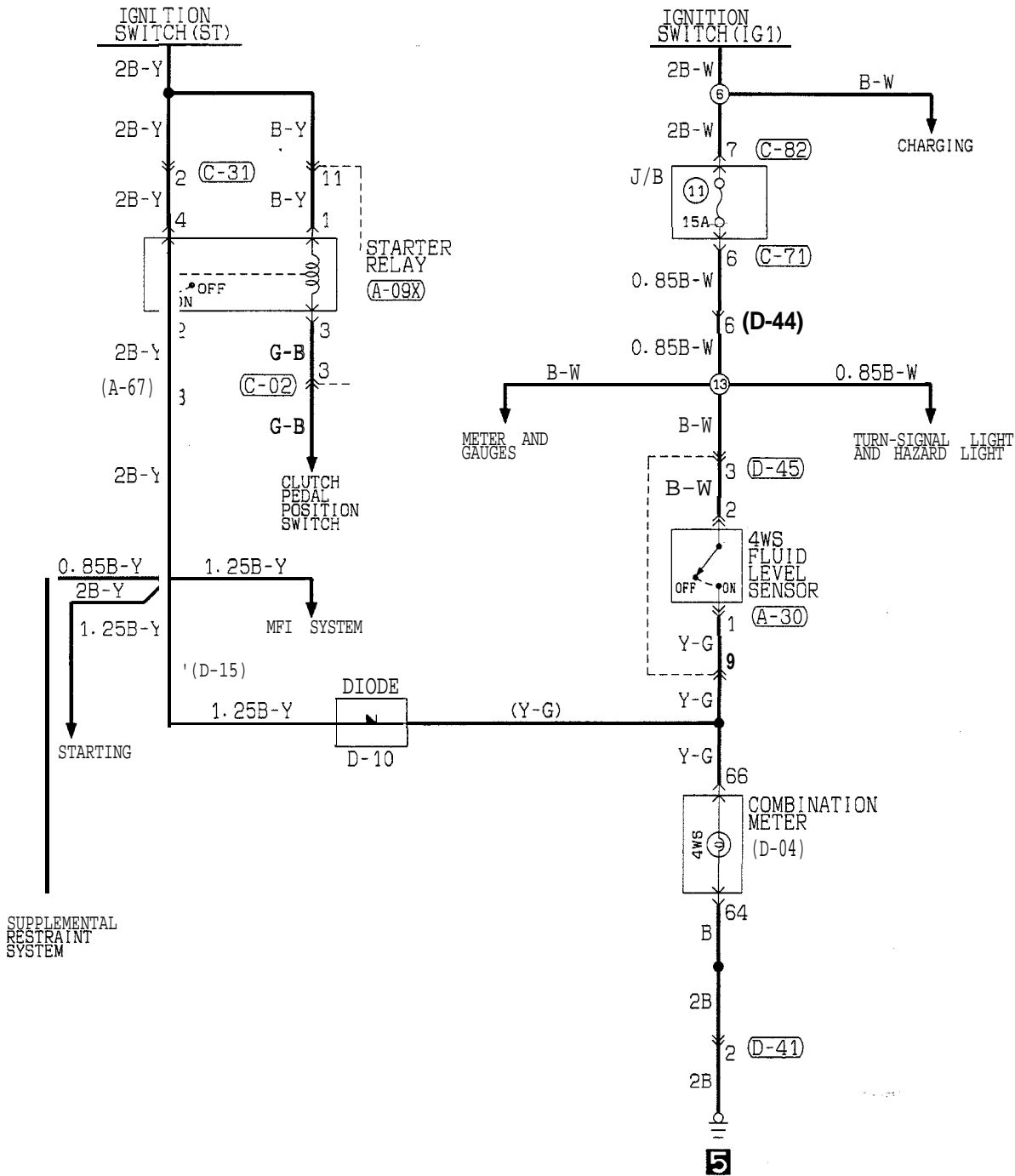

TSB Revision

## &lt;Rear wheels on free rollers&gt;

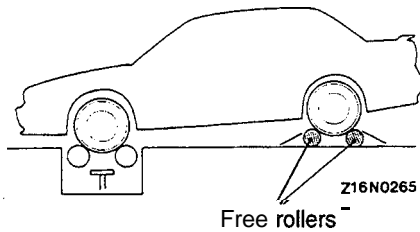

## &lt;Rear wheels raised on jack&gt;

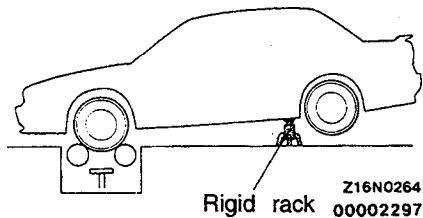
**ON-VEHICLE SERVICE****INSPECTION****SPEEDOMETER CHECK**

- (1) Assure tire pressure at standard value. (Refer to GROUP 31 – Specifications.)
- (2) Set the vehicle on a speedometer tester.
- (3) Set free rollers securely on the floor according to the wheel-base and rear tread of the vehicle (when rear wheels are to be set on free rollers).
- (4) Raise the rear wheels on a jack and place rigid racks to support the specified positions of the side sills (when rear wheels are to be raised on a jack).
- (5) Make sure the parking brake has been set. <FWD>

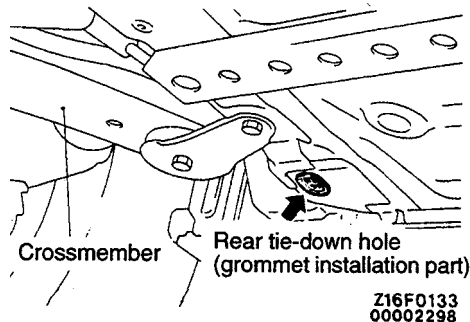
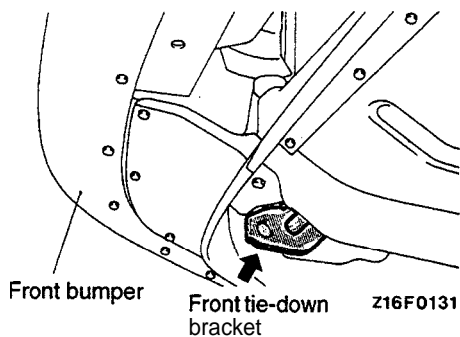
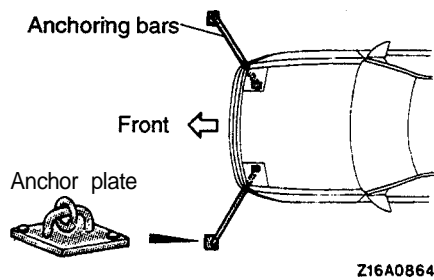

- (6) Attach anchoring bars on the tie-down brackets and secure their ends to the anchor plates.
- (7) Make sure the tension on the right and left bars is the same. Also be sure there is enough tension on each bar.
- (8) Attach a chain or wire to the rear tie-down hole. Make sure the end of the wire or chain is secured firmly.
- (9) Take all other necessary precautions.
- (10) Use a speedometer tester to measure the speedometer's indication error.

**Standard value:**

Standard indication mph	Allowable range mph
20	19-22
40	38-44
80	57-66
<b>80</b>	76-88
<b>100</b>	94-110

**Caution**

Do not operate the clutch or accelerator abruptly or decelerate during the operations.

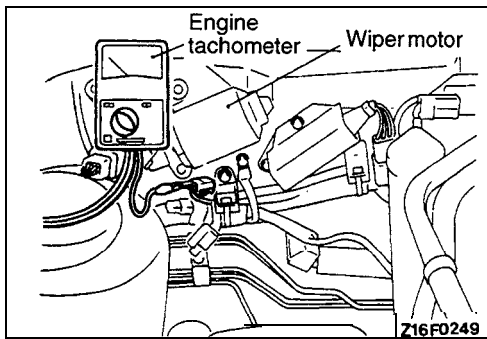

**TACHOMETER CHECK**

- (1) insert paper clip into the engine revolution speed detection terminal provided in the engine compartment, and connect the engine tachometer to the inserted paper clip.

**Caution**

As the tachometer is negative grounded, do not connect battery conversely to prevent damaging transistor and diode.

**NOTE**

For tachometer inspection, use of a fluxmeter-type engine tachometer is recommended. (Because a fluxmeter only needs to be clipped to the high tension cable.)

- (2) Connect the engine tachometer and compare the engine tachometer and tachometer readings. Replace tachometer if difference is excessive.

**Standard value:**

- 1,000 ± 100 rpm
- 3,000 ± 150 rpm
- 5,000 ± 250 rpm
- 6,000 ± 300 rpm

**Caution**

The engine speed signal output from the engine is one-third of the actual speed. When the engine speed is measured, make sure that the engine tachometer is placed in the 2-cylinder range. (The real speed is indicated.)

**FUEL GAUGE SIMPLE CHECK**

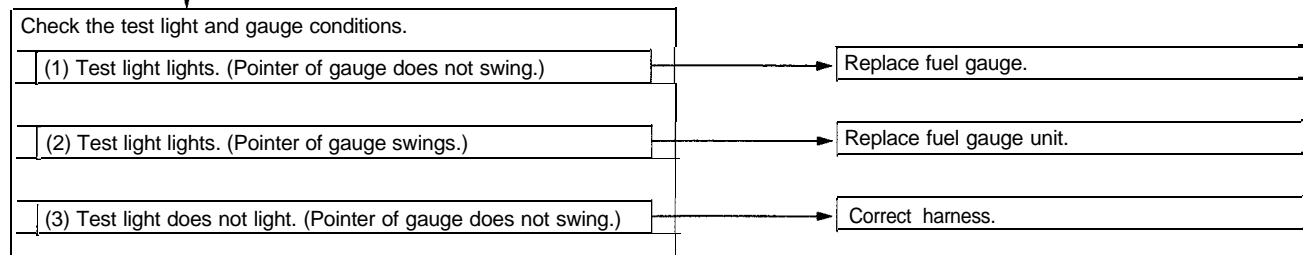
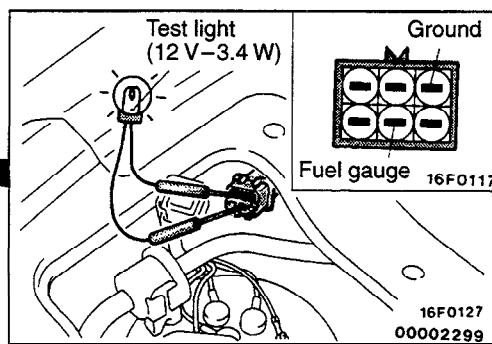
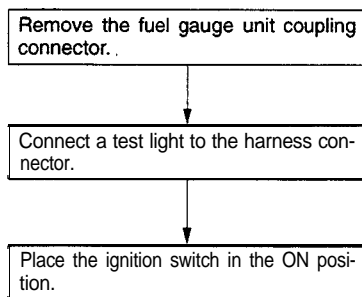

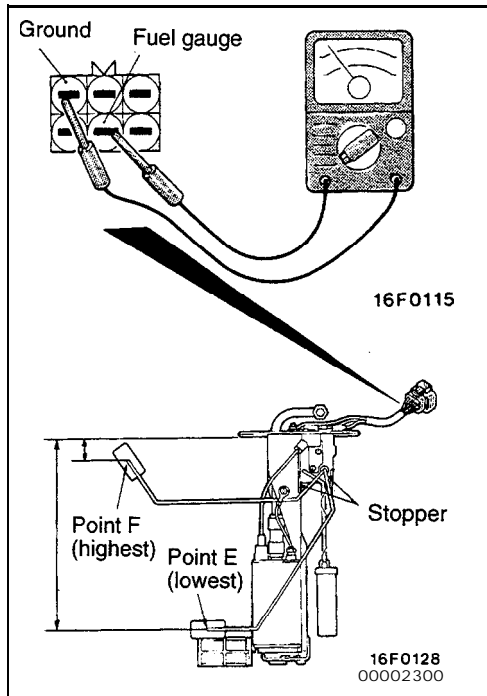

**FUEL GAUGE UNIT CHECK**

To check, remove fuel gauge unit from fuel tank. (Refer to GROUP 13F – Fuel Tank.)

**Fuel Gauge Unit Resistance**

- (1) Check that resistance value between the fuel gauge terminal and ground terminal is at standard value when fuel gauge unit float is at point F (highest) and point E (lowest).

**Standard value:**

**Point F:  $3 \pm 2 \Omega$**

**Point E:  $110 \pm 7 \Omega$**

- (2) Check that resistance value changes smoothly when float moves slowly between point F (highest) and point E (lowest).

**Fuel Gauge Unit Float Height**

Move float and measure the height at point F (highest) and point E (lowest) with float arm touching stopper.

**Standard value:**

**Point F: 18.6-21.6 mm (.73-.85 in.)**

**Point E: 193.4-196.4 mm (7.61-7.73 in.)**

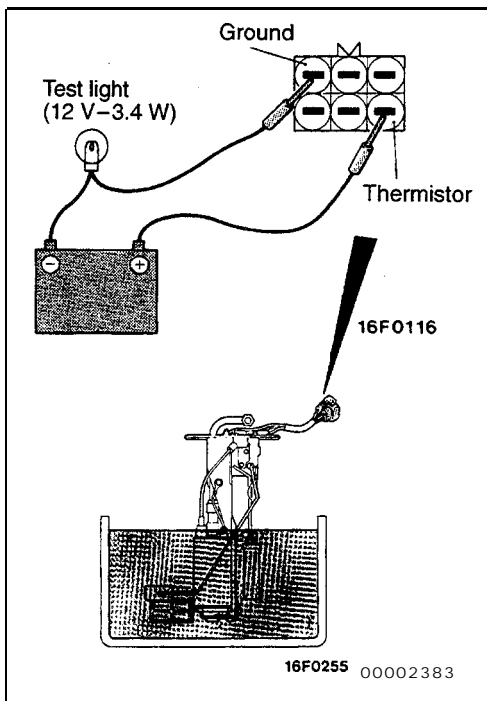
**FUEL SENSOR CHECK**

Connect fuel gauge unit to battery via test light (12 V-3.4 W). Immerse in water. Condition good if light goes off when unit thermistor is in water and lights when unit is removed from water.

**Caution**

**After completing this test, wipe the unit dry and install it in the fuel tank.**

**ENGINE COOLANT TEMPERATURE GAUGE SIMPLE CHECK**

- Remove the water temperature gauge unit coupling connector.
- Connect the harness connector via a test light to the ground.
- Place the ignition switch in the ON position.

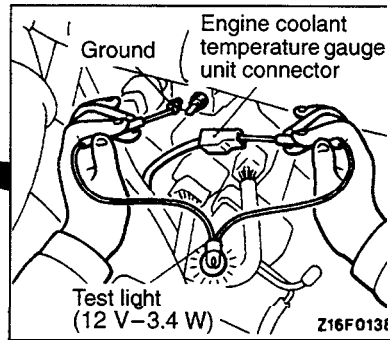

- Check the test light and gauge conditions.
- (1) Test light lights. (Pointer of gauge does not swing.)
  - (2) Test light lights. (Pointer of gauge swings.)
  - (3) Test light does not light. (Pointer of gauge does not swing.)

- Replace water temperature gauge.
- Replace water temperature gauge unit.
- Correct harness.

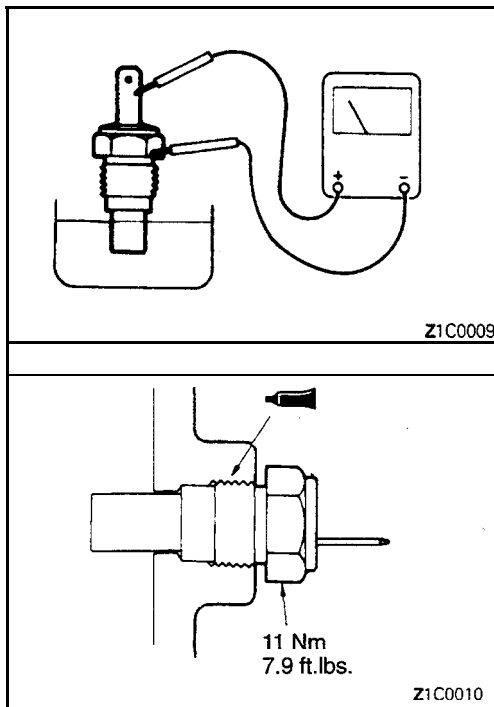

**ENGINE COOLANT TEMPERATURE GAUGE UNIT CHECK**

To check, remove engine coolant temperature gauge unit from the thermostat housing.

**Engine Coolant Temperature Gauge Unit Resistance**

- (1) Immerse unit in 70°C(158°F) water to measure resistance.

**Standard value: 104 ± 13.5 Ω**

- (2) After checking, apply the specified sealant around the thread of engine coolant temperature gauge unit and install on the thermostat housing.

**Specified sealant:**

**3M Nut Locking Part No. 4171 or equivalent**

**OIL PRESSURE GAUGE SIMPLE CHECK**

Remove the oil pressure gauge unit coupling connector.

Connect the harness connector via a test light to the ground.

Place the ignition switch in the ON position.

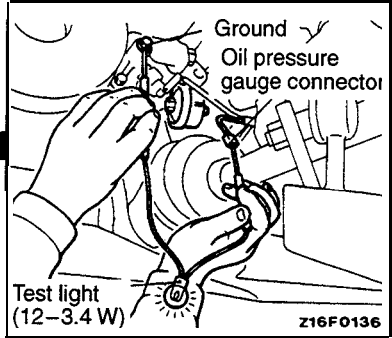

Check the test light and gauge conditions.

(1) Test light lights. (Pointer of gauge does not swing.)
(2) Test light lights. (Pointer of gauge swings.)
(2) Test light does not light. (Pointer of gauge does not swing.)

Replace oil pressure gauge.

Replace oil pressure gauge unit.

Correct harness.

**VOLTAGE GAUGE SIMPLE CHECK**

Start engine and let it idle.

Connect voltmeter to battery.

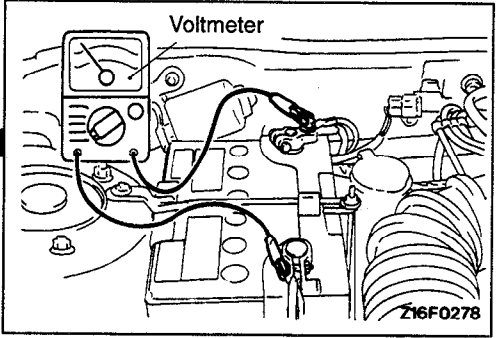

Check voltage gauge for conditions.

(1) Voltage indicated by voltmeter differs from voltage indicated by voltage gauge (position indicated by pointer).
(2) Gauge does not operate.

Replace gauge.

Correct harness or replace gauge.

**COMBINATION METERS**  
**REMOVAL AND INSTALLATION**

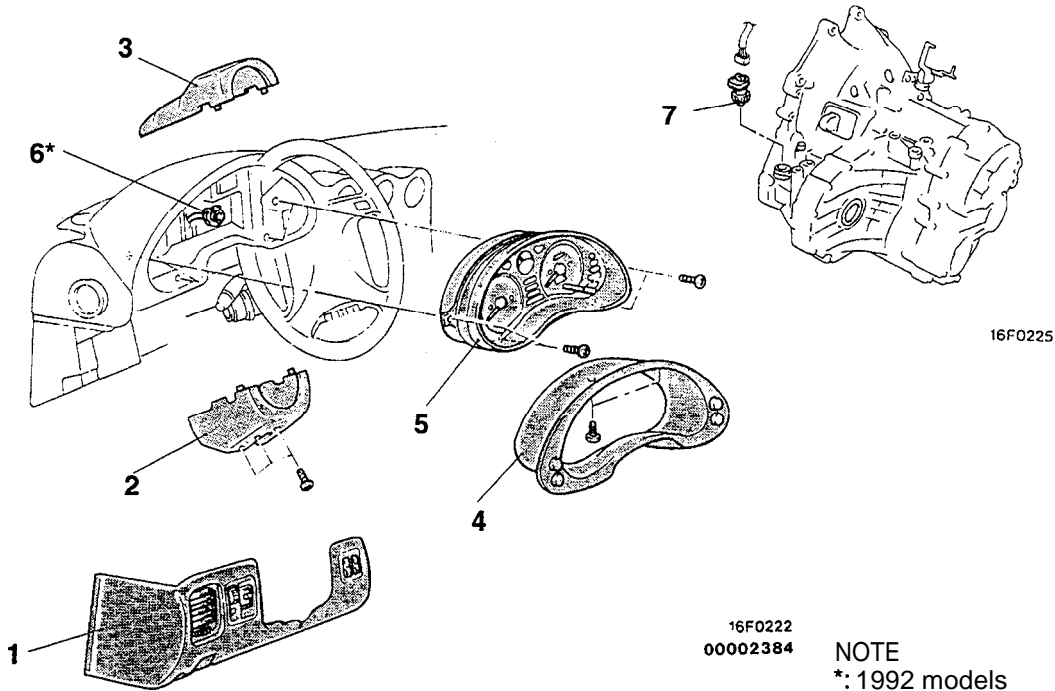

**Removal steps**

- |   |            |  |
|---|------------|--|
| <p>1. Knee protector (Refer to GROUP 52A – Instrument Panel.)</p> <p>2. Column cover, lower</p> <p>3. Column cover, upper</p> <p>4. Meter bezel</p> <p>5. Combination meter</p> | <p>◀B▶</p> | <p>6. Adapter* (Mechanical speedometer type) /Washer tank (Refer to GROUP 51 – Windshield Wiper and Washer.)</p> <p>7. Vehicles speed sensor (Electrical speedometer type)</p> |
|---|------------|--|

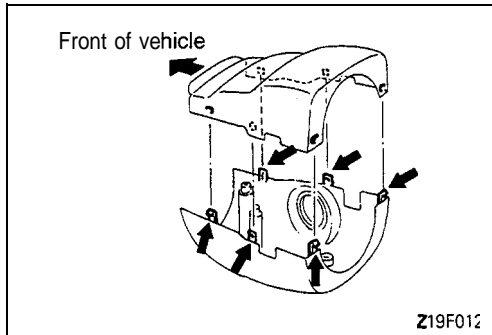

**REMOVAL SERVICE POINTS**

◀A▶ **COLUMN COVER LOWER / COLUMN COVER UPPER REMOVAL**

After the screws have been removed, remove the covers, while making sure not to break the grippers.

◀B▶ **ADAPTER REMOVAL <Mechanical Speedometer Type>**

- (1) Disconnect the speedometer cable at the transaxle end of the cable.
- (2) Pull the speedometer cable slightly toward the vehicle interior, release the lock by turning the adaptor to the left or right, and then remove the adapter.

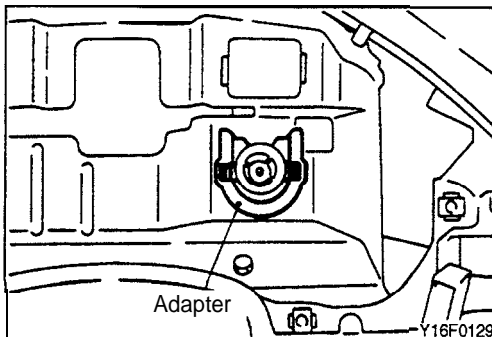

DISASSEMBLY AND REASSEMBLY

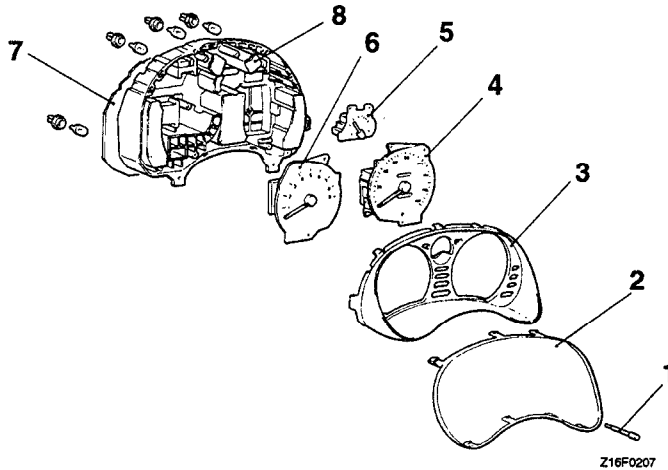

**Disassembly steps**

- |                            |                          |
|----------------------------|--------------------------|
| 1. Trip counter reset knob | 5. Fuel gauge            |
| 2. Meter glass             | 6. Tachometer            |
| 3. Window plate            | 7. Printed-circuit board |
| 4. Speedometer             | 8. Meter case            |

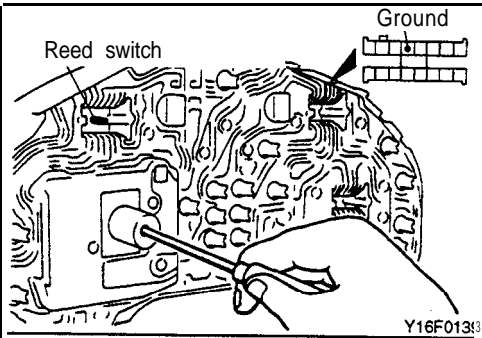

**INSPECTION**

**REED SWITCH CHECK**

**<Mechanical Speedometer Type>**

Use circuit tester to check circuit repeats off/on between terminals when speedometer shaft turned several times.

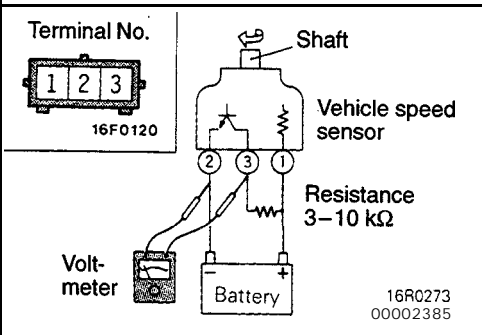

**VEHICLES SPEED SENSOR CHECK**

**<Electrical Speedometer Type>**

- (1) Remove the vehicles speed sensor and connect as shown in the illustration, using a 3–10 kΩ resistance.
- (2) Use a voltmeter to check for voltage at terminals (2) and (3) when the pulse generator shaft is turning. (One revolution is four pulses.)

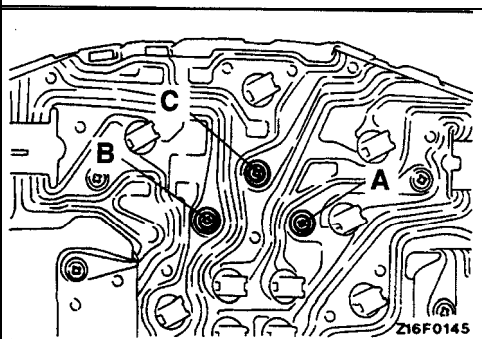

**FUEL GAUGE CHECK**

Measure resistance between terminals with circuit tester.

**Standard value:**

- |            |                      |
|------------|----------------------|
| <b>A-B</b> | <b>Approx. 254 Ω</b> |
| <b>A-C</b> | <b>Approx. 101 Ω</b> |
| <b>B-C</b> | <b>Approx. 153 Ω</b> |

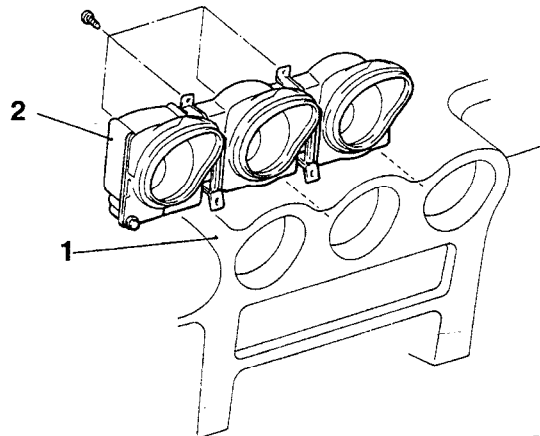
**COMBINATION GAUGES****REMOVAL AND INSTALLATION**

Z16F0211

**Removal steps**

1. Instrument panel  
(Refer to GROUP 52A – Instrument Panel.)

- Distribution duct  
[Refer to GROUP 55 – Ventilators (Instrument Panel).]
2. Combination gauge

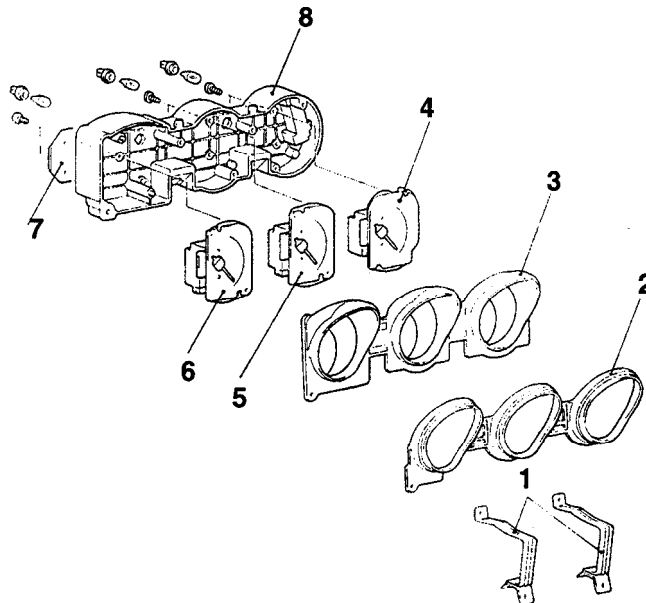
**DISASSEMBLY AND REASSEMBLY**

Z16F0213

**Disassembly steps**

1. Gauge bracket
2. Gauge glass
3. Window plate
4. Voltage gauge <Non-Turbo> or pressure gauge <Turbo>
5. Oil pressure gauge
6. Engine coolant temperature gauge
7. Printed-circuit board
8. Gauge case

TSB Revision
--------------

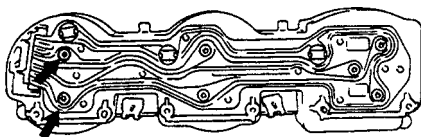

Z16F0143

**INSPECTION****PRESSURE GAUGE CHECK <Turbo>**

Measure resistance between terminals with circuit tester.

**Standard value: Approx. 72  $\Omega$**

**VOLTAGE GAUGE CHECK <Non-Turbo>**

Refer to P.54-30

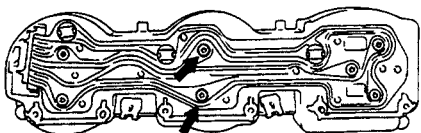

Z16F0142

**OIL PRESSURE GAUGE CHECK**

Measure resistance between terminals with circuit tester.

**Standard value: Approx. 42  $\Omega$**

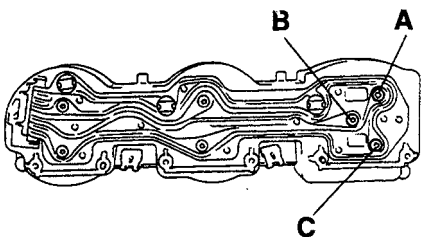

Z16F0141

**ENGINE COOLANT TEMPERATURE GAUGE CHECK**

- (1) Remove the IG terminal screw from area A.
- (2) Measure resistance between terminals with circuit tester.

**Caution**

For inspection, use a circuit tester which uses a measurement current of 4 mA or less.

**Standard value:**

A-B	Approx. 51 $\Omega$
A-C	Approx. 139 $\Omega$
B-C	Approx. 190 $\Omega$

# LIGHTING SYSTEM

## SPECIFICATIONS

### GENERAL SPECIFICATIONS

#### Exterior lights

Items	Specifications
Headlight W	65/45*1, 60/51 *2
Fog light W	55
Front combination light	Turn-signal light / side marker light CP
	27/8 (1157)*1 or 27 (1156)*2
Rear combination light	Turn-signal light / side marker and tail light CP
	32/2 (2057)
	Stop light / side marker and tail light CP
	32/2 (2057)
Back-up light CP	32 (1156)
License plate light CP	3 (168)
High-mounted stop light	Vehicles without rear spoiler CP
	32 (1156)
	Vehicles with fixed rear spoiler W
	4
	Vehicles with active rear spoiler
	LED (Light Emitting Diode)
Engine compartment inspection light W	3.8 (194)

#### Interior lights

Items	Specifications
Foot light W	3.4 (158)
Dome light W	8
Spot light W	8
Door light W	5
Glove compartment light W	3.4 (158)
Luggage compartment light W	5

#### NOTE

The values in parentheses denote SAE trade number.

\*1 Up to 1993 models





\*2 From 1994 models

### SERVICE SPECIFICATIONS

Items	Limit
Headlight intensity	20,000 cd or more

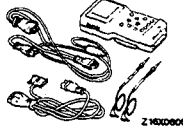

## SPECIAL TOOLS

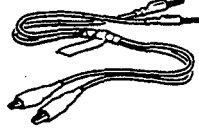
Tool	Tool number and name	Supersession	Application
	MB991341  Scan tool (Multi-use tester <MUT>)	MB991 341 C	Up to 1993 models Checking the lighting system
	ROM Pack (For the number, refer to GROUP 00 – Precautions Before Service)		
	MB991502  Scan tool (MUT-II)	MB991 502	All models Checking the lighting system
 z16X0607	ROM Pack		
	MB991 529 Diagnostic trouble code check harness	MB991 529	From 1994 models Checking the lighting system using a voltmeter

## TROUBLESHOOTING

### HEADLIGHT

#### OPERATION

##### <Headlights ON operation>

- Turn the lighting switch to “HEAD”, and the contact point of the headlight relay will be closed to turn “ON” the headlight relay.
- When the dimmer switch is placed in the LO position, the headlight low-beams go on. On vehicles up to 1993 model, when the switch is placed in the HI position, the headlight high-beams go on. On vehicles from 1994 model, when the switch is placed in the HI position, the headlight high-beams and low-beams go on.

##### <High-beam indicator light>

- When the high-beam is lit or when the passing switch is activated, the high-beam indicator light will be lit.

##### <Light automatic shut-OFF system>

- If the driver's door is opened after the ignition switch is turned to “OFF” or the ignition switch is turned to “OFF” after the driver's door is opened when the headlights are lit, the current which flows to the coil side of the headlight relay will be cut off by the light automatic shut-OFF unit opening the contact point, and the headlight relay will be turned “OFF” to automatically shut off the headlights.
- To turn the headlights on again after they are automatically shut off, turn the lighting switch to “OFF” once and then back to “HEAD”, or turn the ignition switch to “ACC” or “ON”, and the automatic shut-OFF will be cancelled and the current will flow from the light automatic shut-OFF unit to the coil side of the headlight relay again to close the contact point. Thus, the headlight relay will be turned “ON” to turn on the headlights.

#### NOTE

When the lighting switch is at “HEAD”, the light automatic shut-OFF system is valid for tail lights, parking and side marker lights, license plate light, illumination light, etc.

(Refer to P.54-70.)

##### <Pop-up operation—Operation by lighting switch> (Up to 1993 models)

- When the lighting switch is placed in the HEAD position, current flows through multi-purpose fuse (6) to the lighting switch, and the ETACS control unit. Then the UP timer circuit in the ETACS control unit is operated, and current flows from the ETACS control unit to the U con-

tact of the pop-up motor U/D (UP/DOWN) switch, the coil of the pop-up motor relay and ground, causing the contacts of the pop-up motor relay to close.

When the contacts of the pop-up motor relay close, current flows through the contacts of the pop-up motor relay to the pop-up motor and ground, causing the pop-up motor to rotate, which brings the headlights to the UP position. The pop-up motor rotates until the automatic UP stop position is reached, then the contacts of the interlocked U/D (UP/DOWN) switch change from the U to D contacts. As a result, the contacts of the pop-up motor relay open to cut off the current supplied to the pop-up motor. Then the pop-up motor ceases to rotate, holding the headlights in the UP position.

- When the lighting switch is placed in the TAIL or OFF position, current flows through the multi-purpose fuse (6) to the lighting switch, and the ETACS control unit. Then the DOWN timer circuit in the ETACS control unit is operated and current flows from the ETACS control unit to the DOWN contacts of the pop-up motor U/D (UP/DOWN) switch, the coil of the pop-up motor relay and ground, causing the contacts of the pop-up motor relay to close.

When the contacts of the pop-up motor relay close, current flows through the contacts of the pop-up motor relay to the pop-up motor and ground, causing the pop-up motor to rotate, which brings the headlights to the DOWN position.

The pop-up motor rotates until the automatic DOWN stop position is reached, then the contacts of the interlocked U/D (UP/DOWN) switch change from the D to U contacts. As a result, the contacts of the pop-up motor relay open to cut off current supply to the pop-up motor. Then the pop-up motor ceases to rotate, holding the headlights in the DOWN position.

##### <Pop-up operation—Operation by pop-up switch> (Up to 1993 models)

- When the pop-up switch is placed in the UP position, current flows through multi-purpose fuse (6) to the lighting switch, the pop-up switch and the ETACS control unit, which brings the headlights to the UP position and holds them in the UP position just like when they are operated by the lighting switch.
- When the pop-up switch is placed in the DOWN position, current flows through the multi-purpose fuse (6) to the lighting switch, the pop-up switch and the ETACS control unit, which brings the headlights to the DOWN position and holds them in the DOWN position just like when they are operated by the lighting switch.

## TROUBLESHOOTING HINTS

Phenomenon		Checking method
Headlights don't come on.	But the tail lights do illuminate.	Check the headlight relay. (Refer to P.54-108.)
		Check the lighting switch. (Refer to P.54-113.)
		Check the light automatic shut-OFF unit. (Refer to P.54-108.)
	The tail lights also don't illuminate.	Check the fusible link (3).
The low beam at both sides doesn't illuminate.		Check the "LO" contacts of the dimmer switch.
The upper beam at both sides doesn't illuminate.	The passing signal functions OK.	Check the "HI" contacts of the dimmer switch.
	The passing signal doesn't function.	Check the dimmer switch. (Refer to P.54-114.)
One headlight doesn't illuminate.		Check the bulb.
Can't switch from low to high beam or vice versa.		Check the dimmer switch. (Refer to P.54-114.)
The high beam indicator light doesn't illuminate.	The high beam of the headlights is normal.	Check dedicated fuse No. (5).
		Check the bulb.
Headlights are not automatically shut off.	Tail lights are automatically shut off.	Check the light automatic shut-OFF unit. (Refer to P.54-108.)
		Check the driver's side door switch. (Refer to GROUP 52B – Door Assembly.)
		Check the light automatic shut-OFF unit. (Refer to P.54-108.)
Headlights do not rise*.	They rise only when the lighting switch is operated.	Check the pop-up switch input signal. (Refer to P.54-109.)
		Check the pop-up switch. (Refer to P.54-109.)
	They rise only when the pop-up switch is operated.	Check the lighting switch. (Refer to P.54-113.)
Headlights do not retract*.		Check the pop-up switch input signal. (Refer to P.54-109.)
		Check the pop-up switch. (Refer to P.54-109.)
One headlight does not move*.		Check the pop-up motor relay. (Refer to P.54-109.)
		Check the pop-up motor. (Refer to P.54-104.)

## NOTE

(1) \*Up to 1993 models

(2) For information concerning the theft-alarm system, refer to P.54-222.

COMPONENT LOCATION

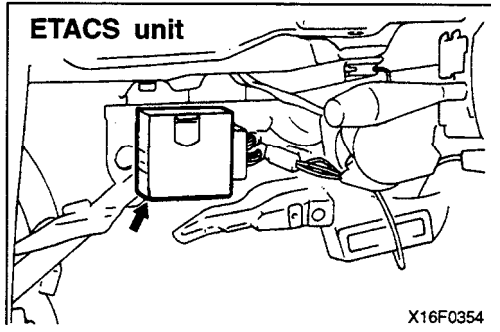
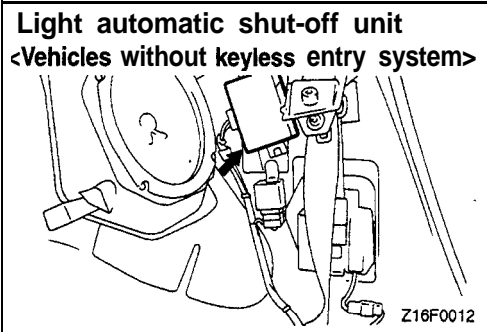
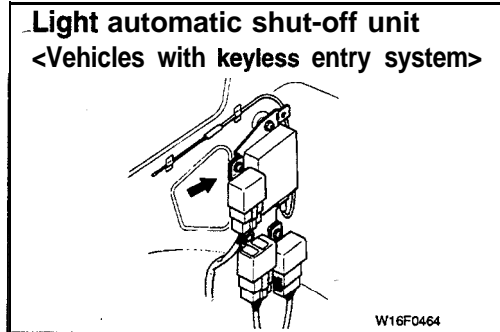
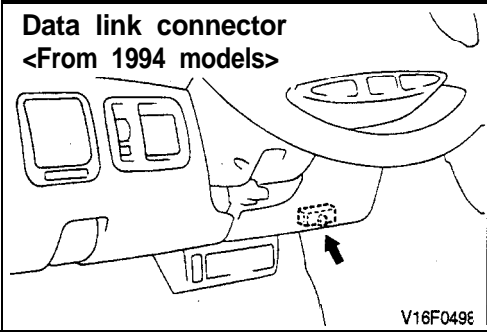
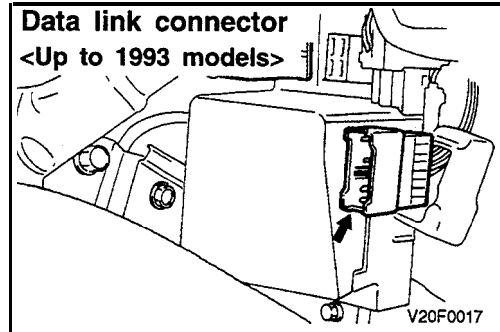
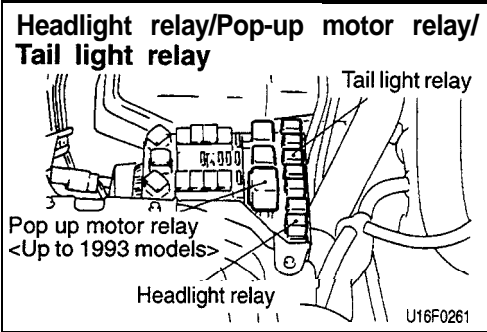

CIRCUIT DIAGRAM <VEHICLES WITHOUT THEFT-ALARM SYSTEM (UP TO 1993 MODELS)>

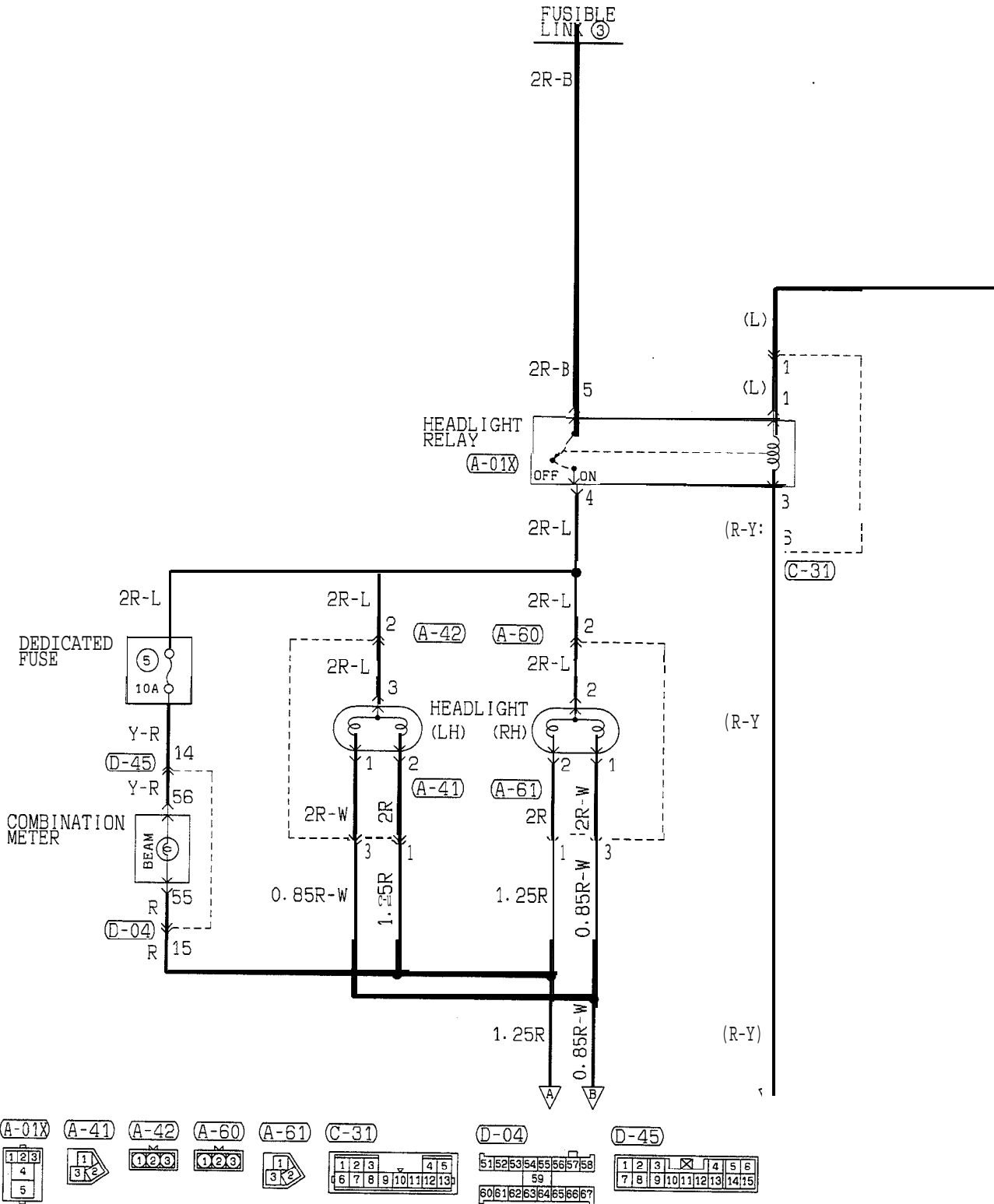

TSB Revision

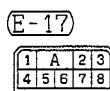
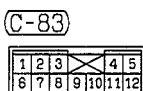
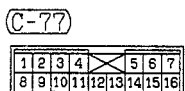
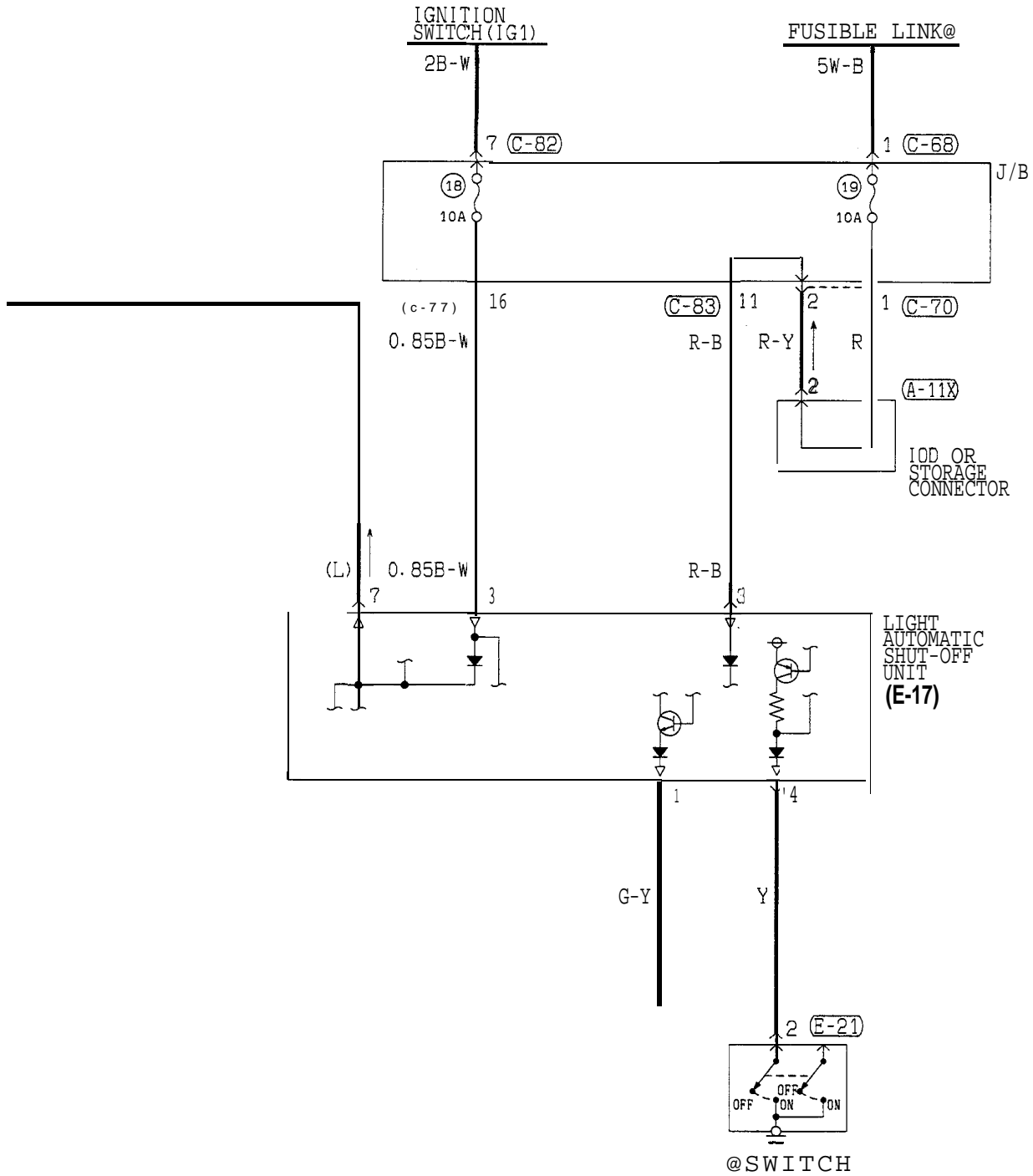

CIRCUIT DIAGRAM <VEHICLES WITHOUT THEFT-ALARM SYSTEM (UP TO 1993 MODELS)>  
(CONTINUED)

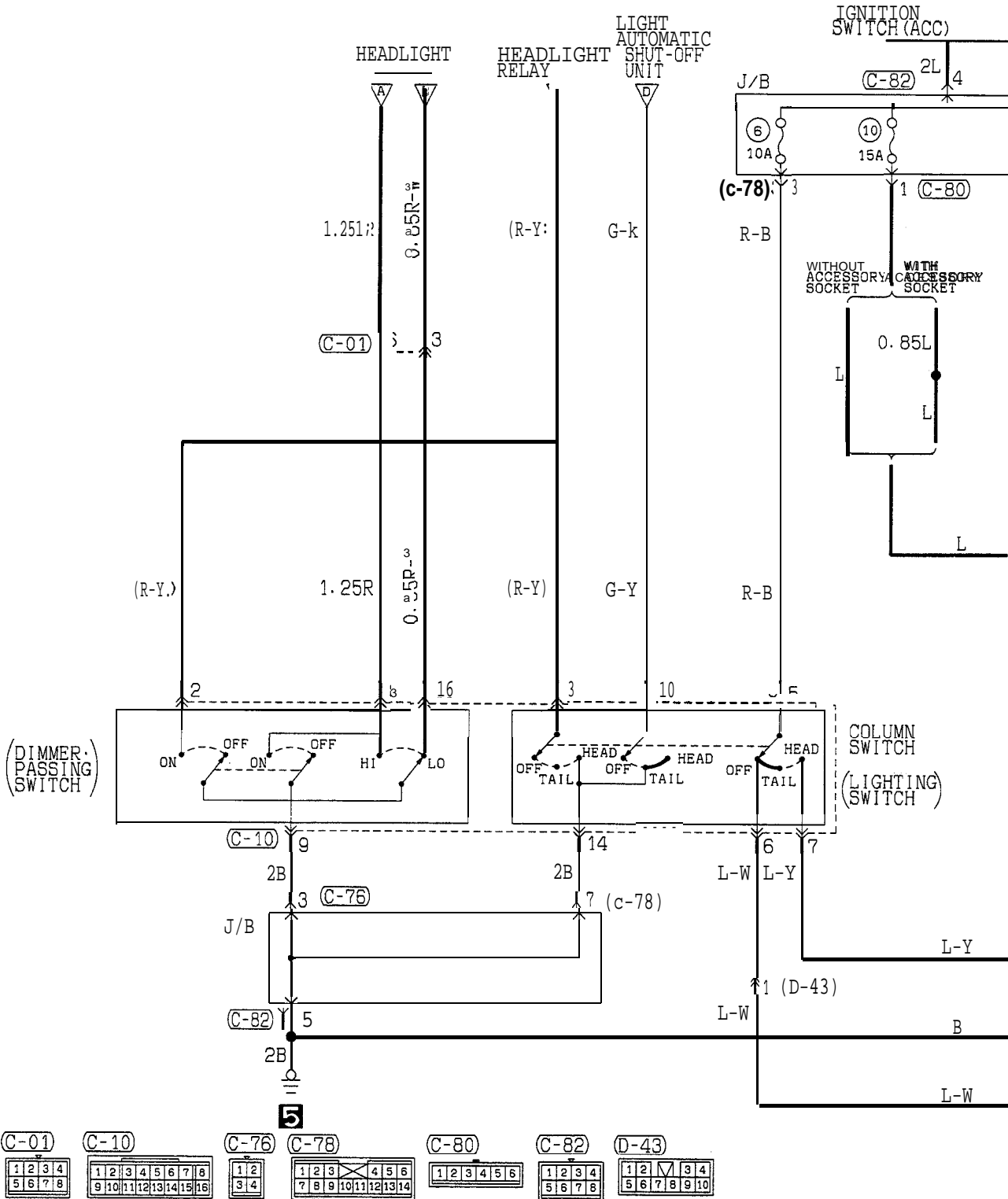

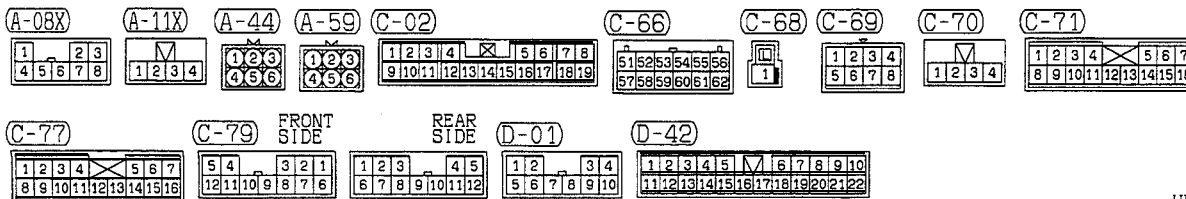
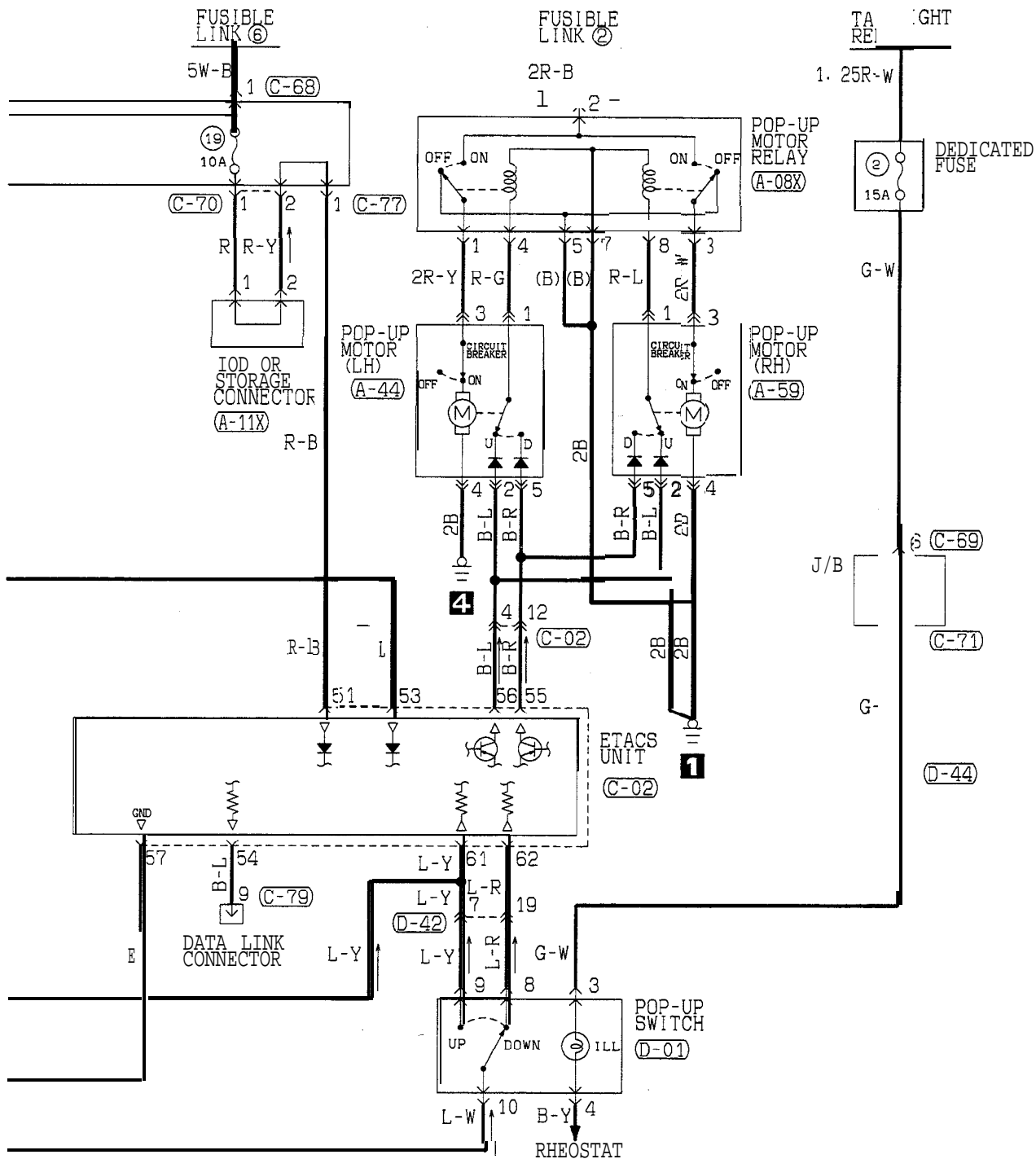

HR08M00BB

TSB Revision



CIRCUIT DIAGRAM <VEHICLES WITH THEFT-ALARM SYSTEM (UP TO 1993 MODELS)>

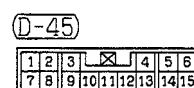
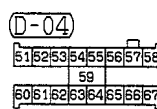
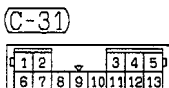
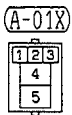
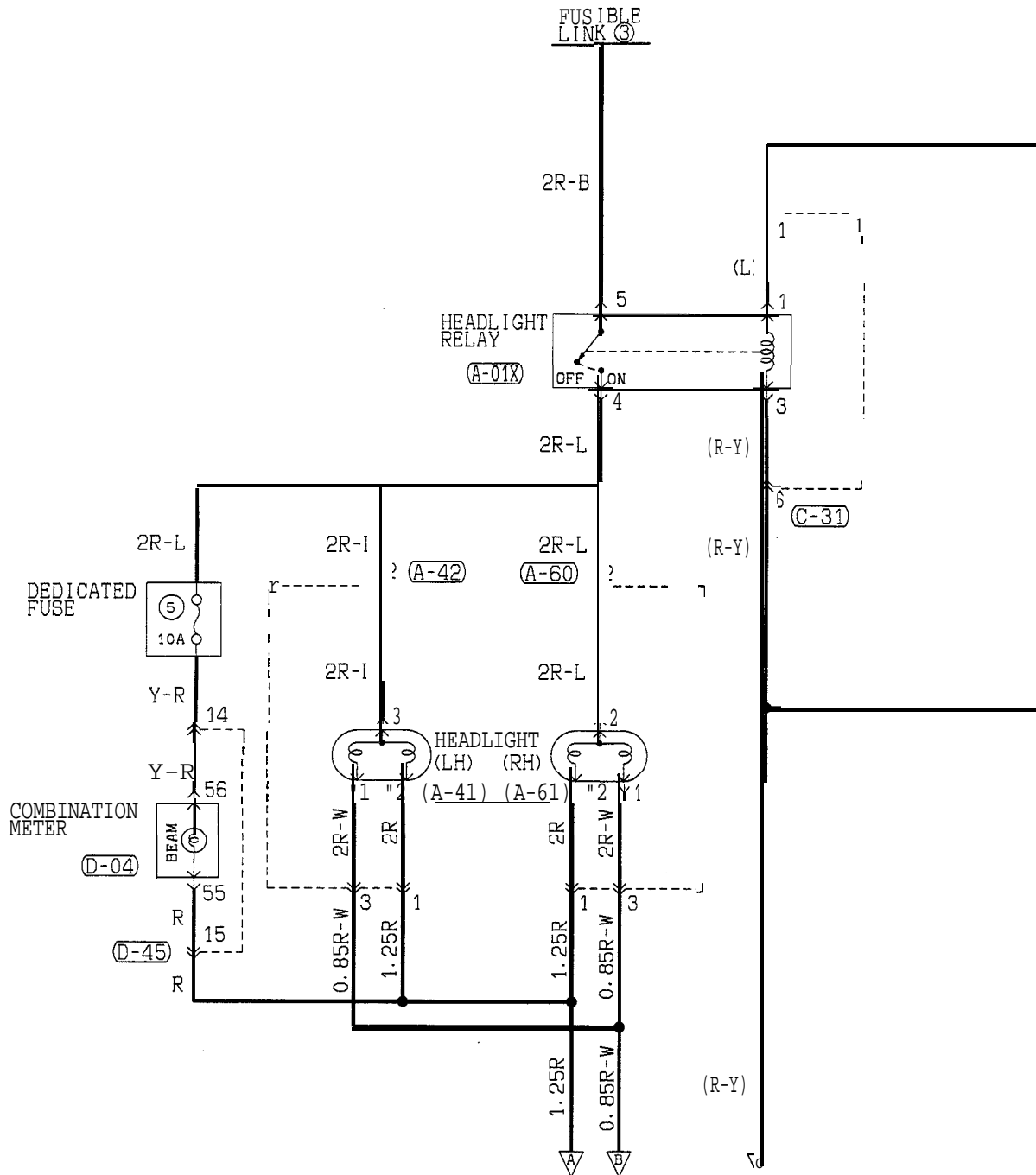

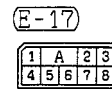
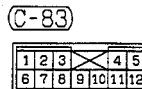
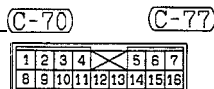
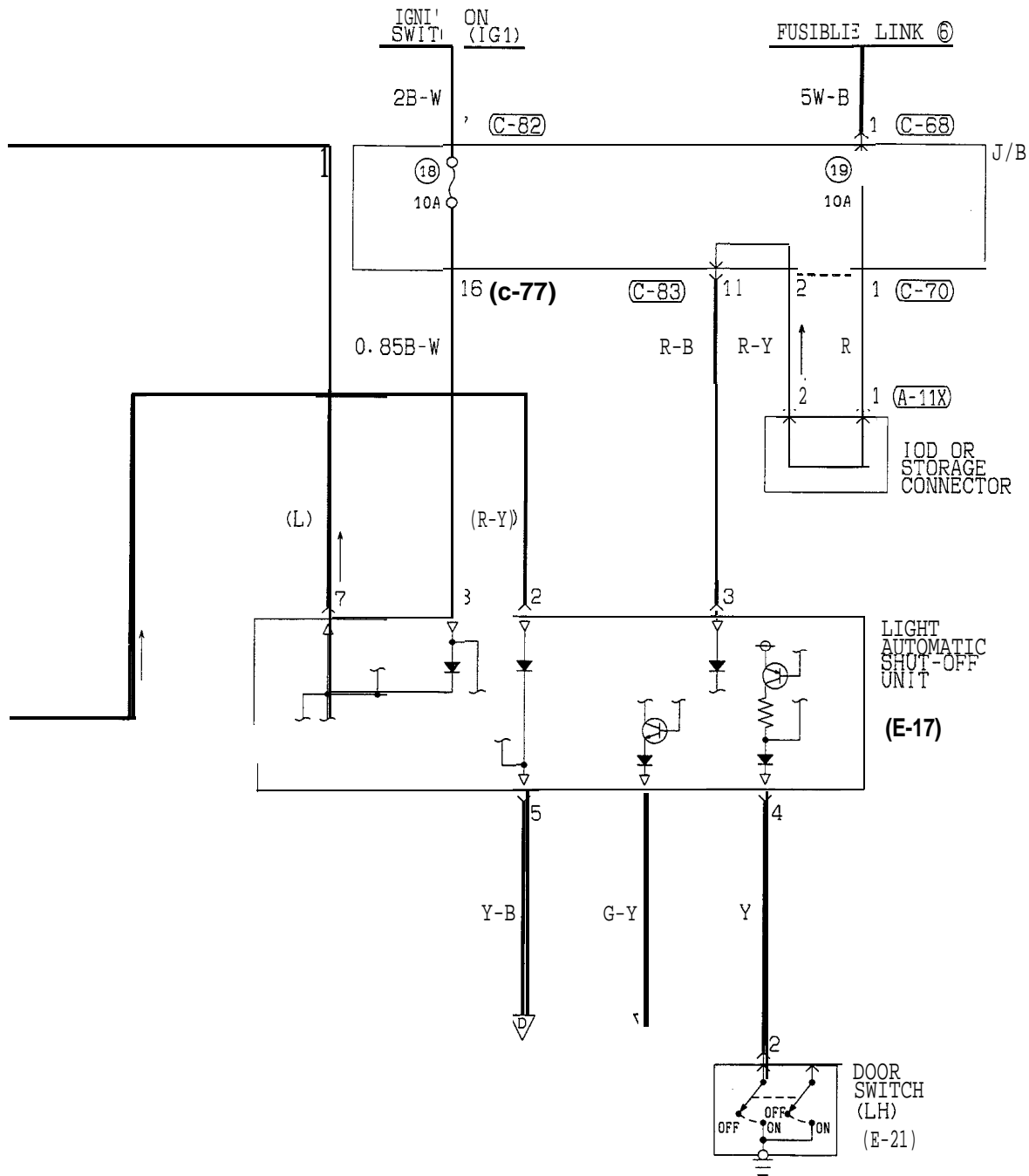

TSB Revision

CIRCUIT DIAGRAM <VEHICLES WITH THEFT-ALARM SYSTEM (UP TO 1993 MODELS)> (CONTINUED)

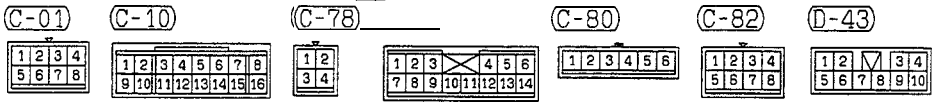
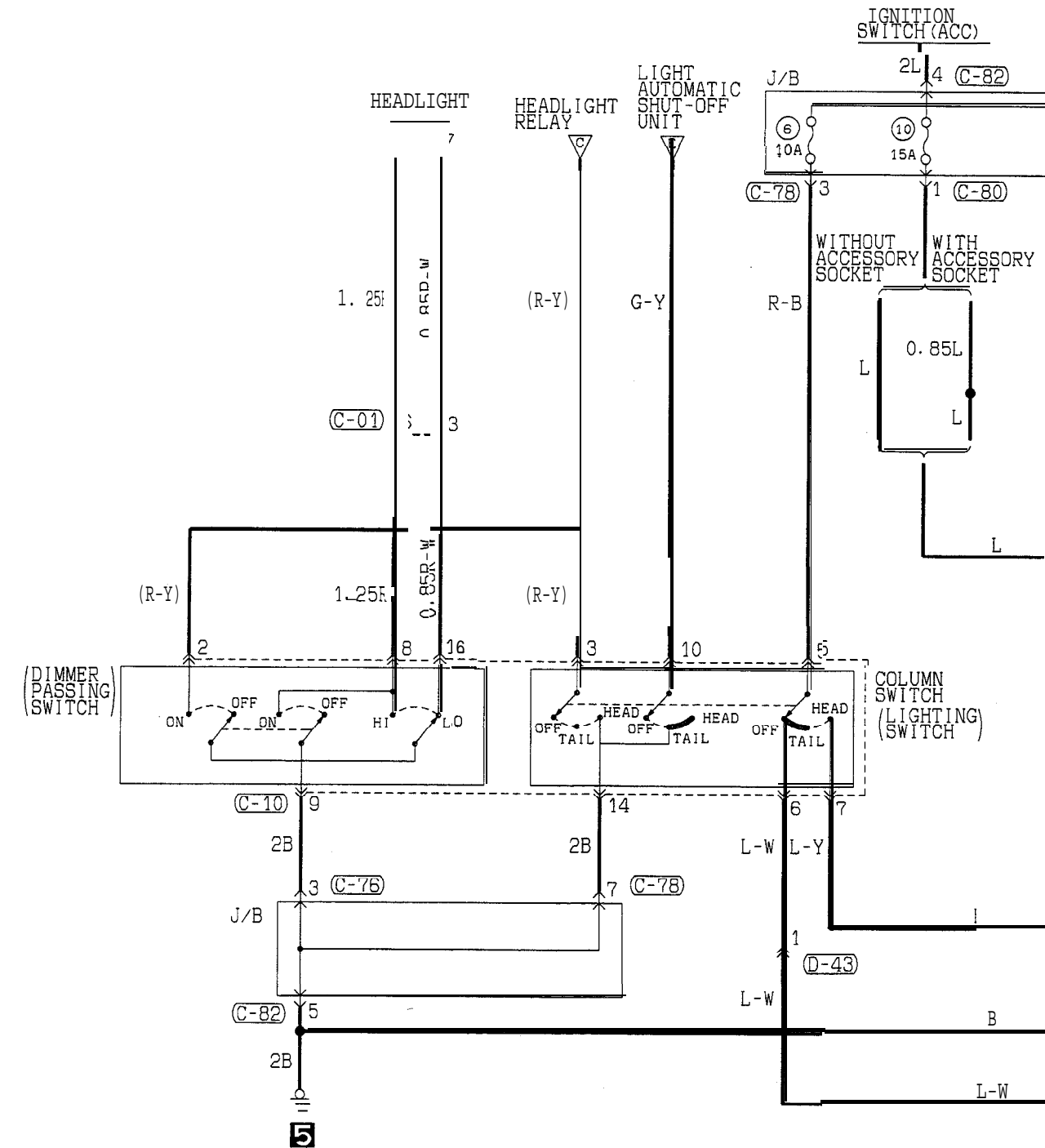

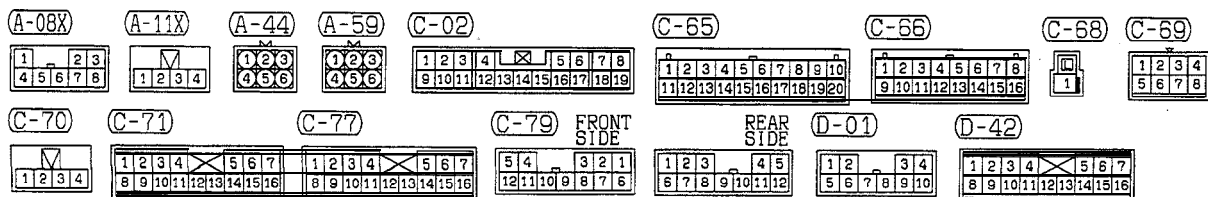
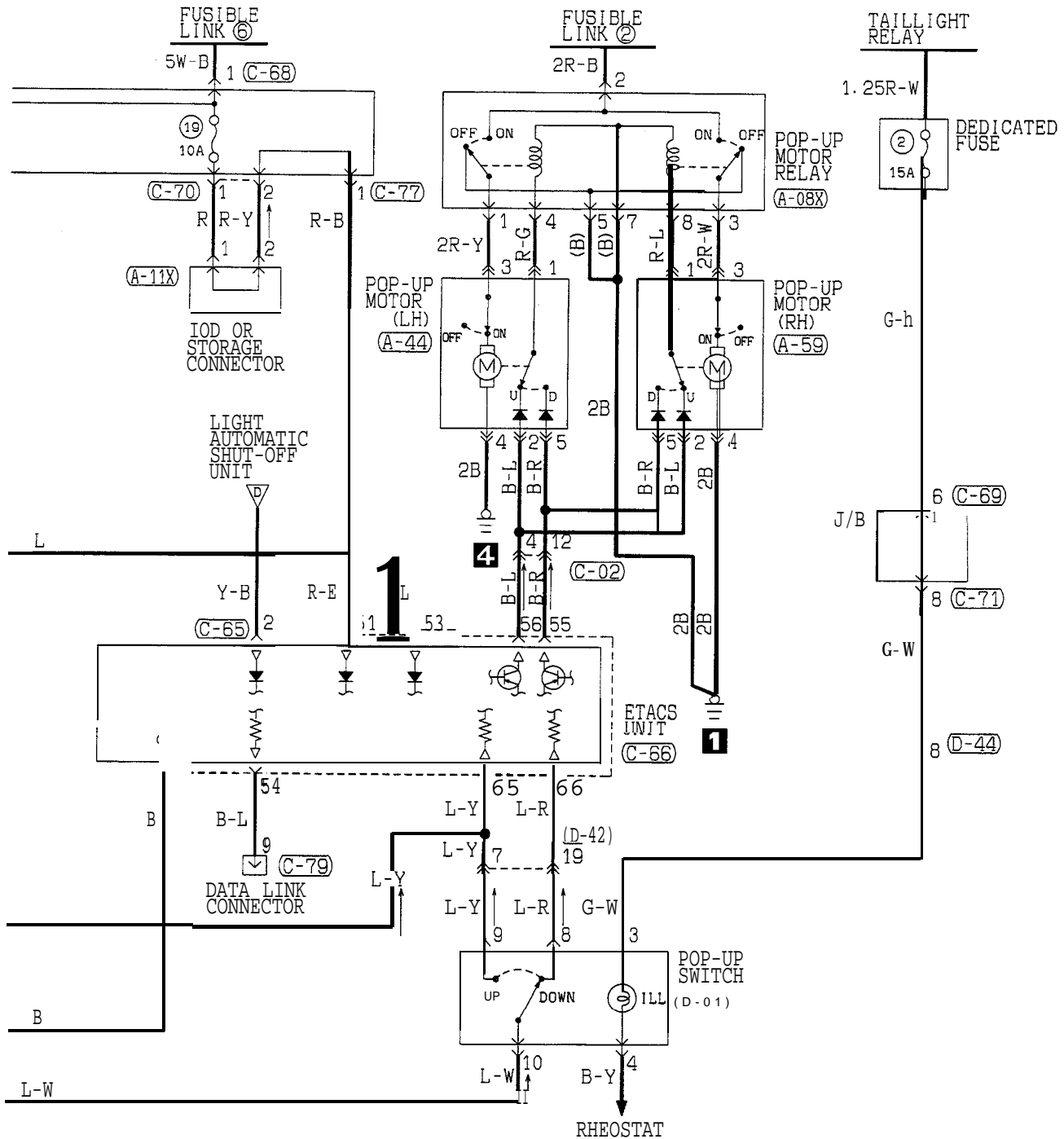

TSB Revision

CIRCUIT DIAGRAM <VEHICLES WITHOUT THEFT-ALARM SYSTEM (FROM 1994 MODELS)>

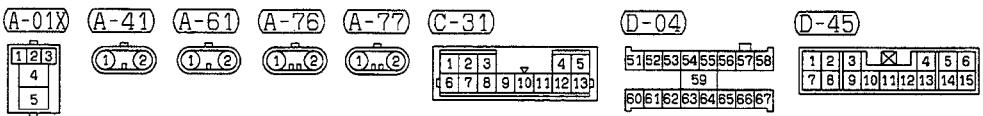
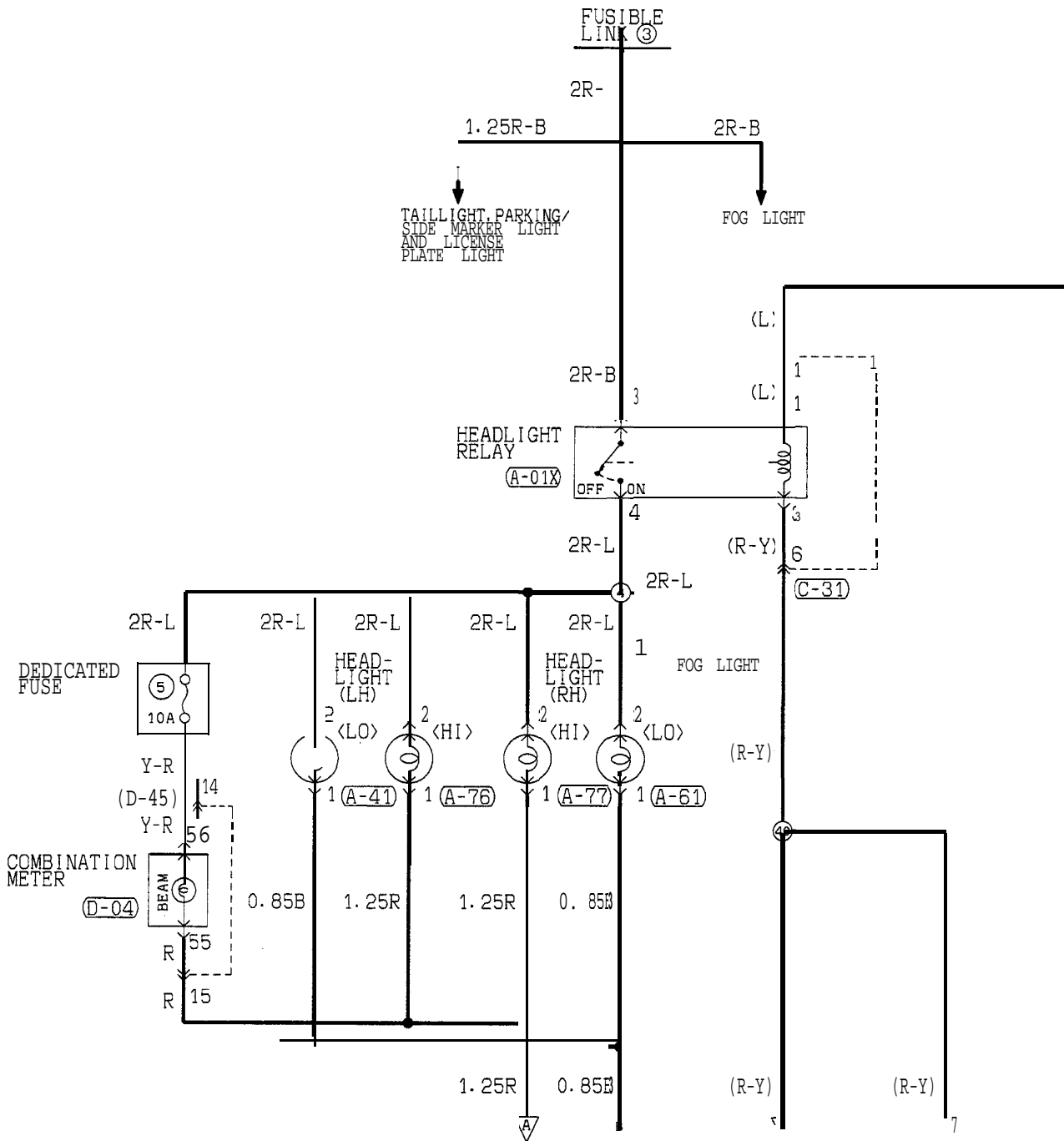

TSB Revision

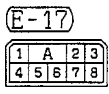
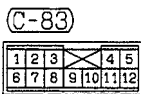
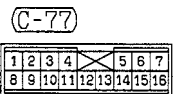
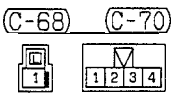
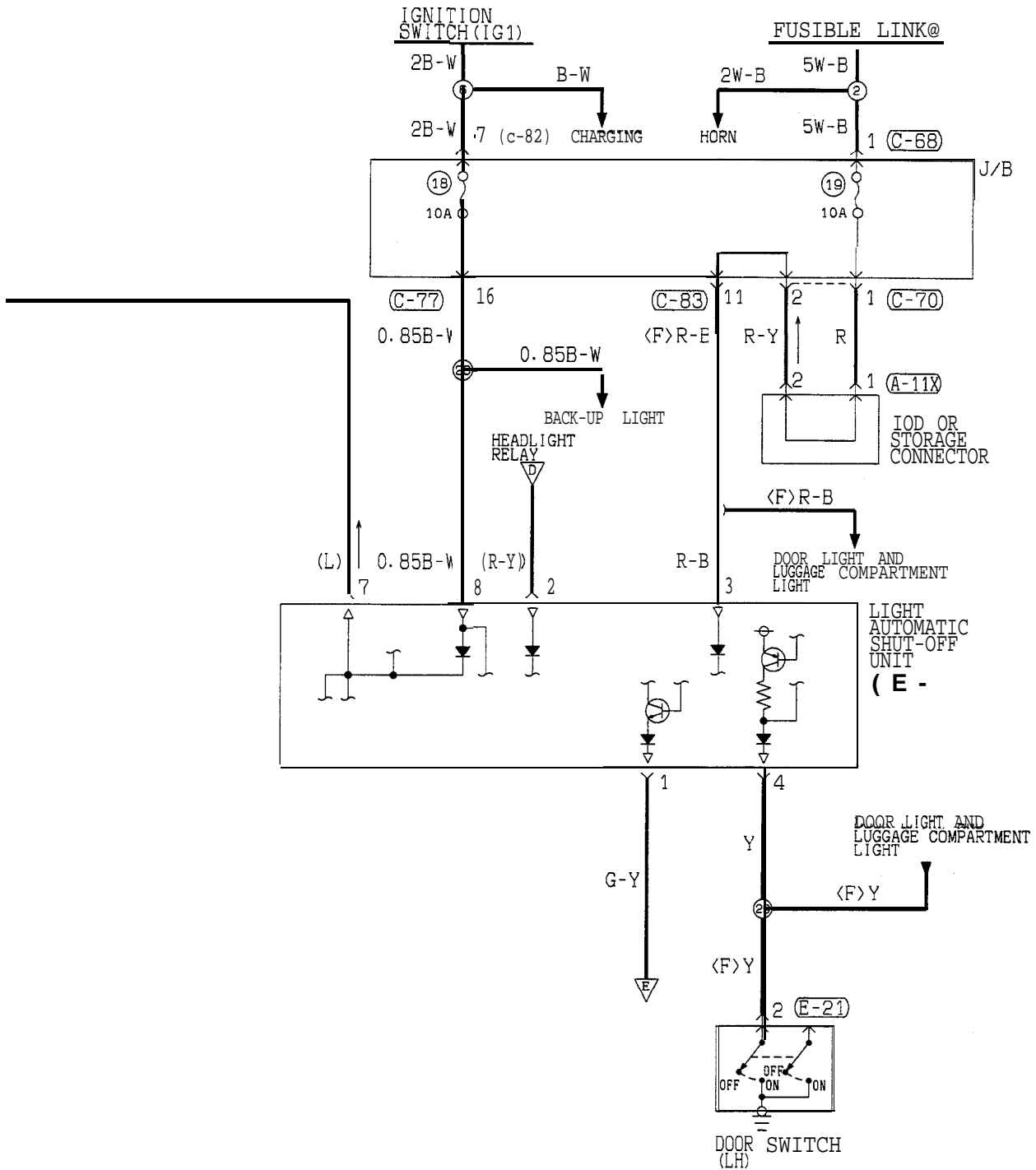

TSB Revision

CIRCUIT DIAGRAM <VEHICLES WITHOUT THEFT-ALARM SYSTEM (FROM 1994 MODELS)>  
(CONTINUED)

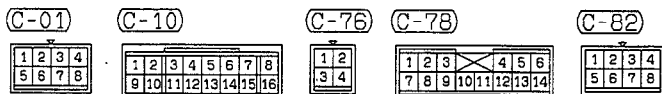
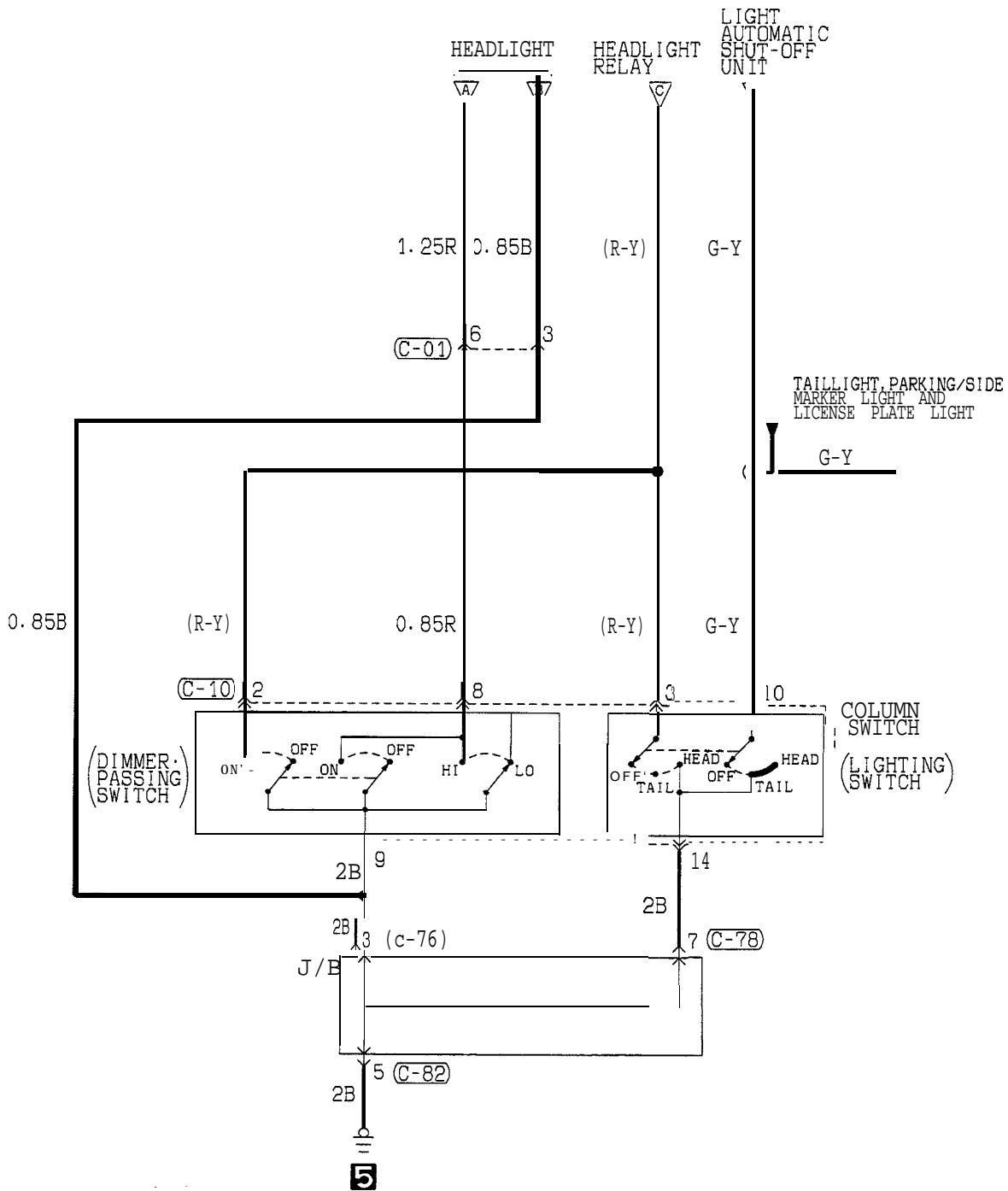

TSB Revision

NOTES



CIRCUIT DIAGRAM <VEHICLES WITH THEFT-ALARM SYSTEM (FROM 1994 MODELS)>

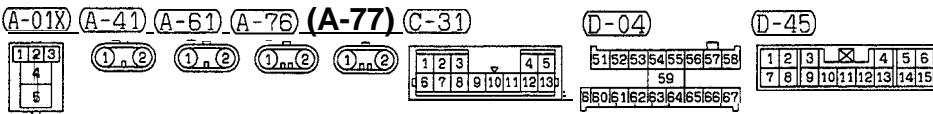
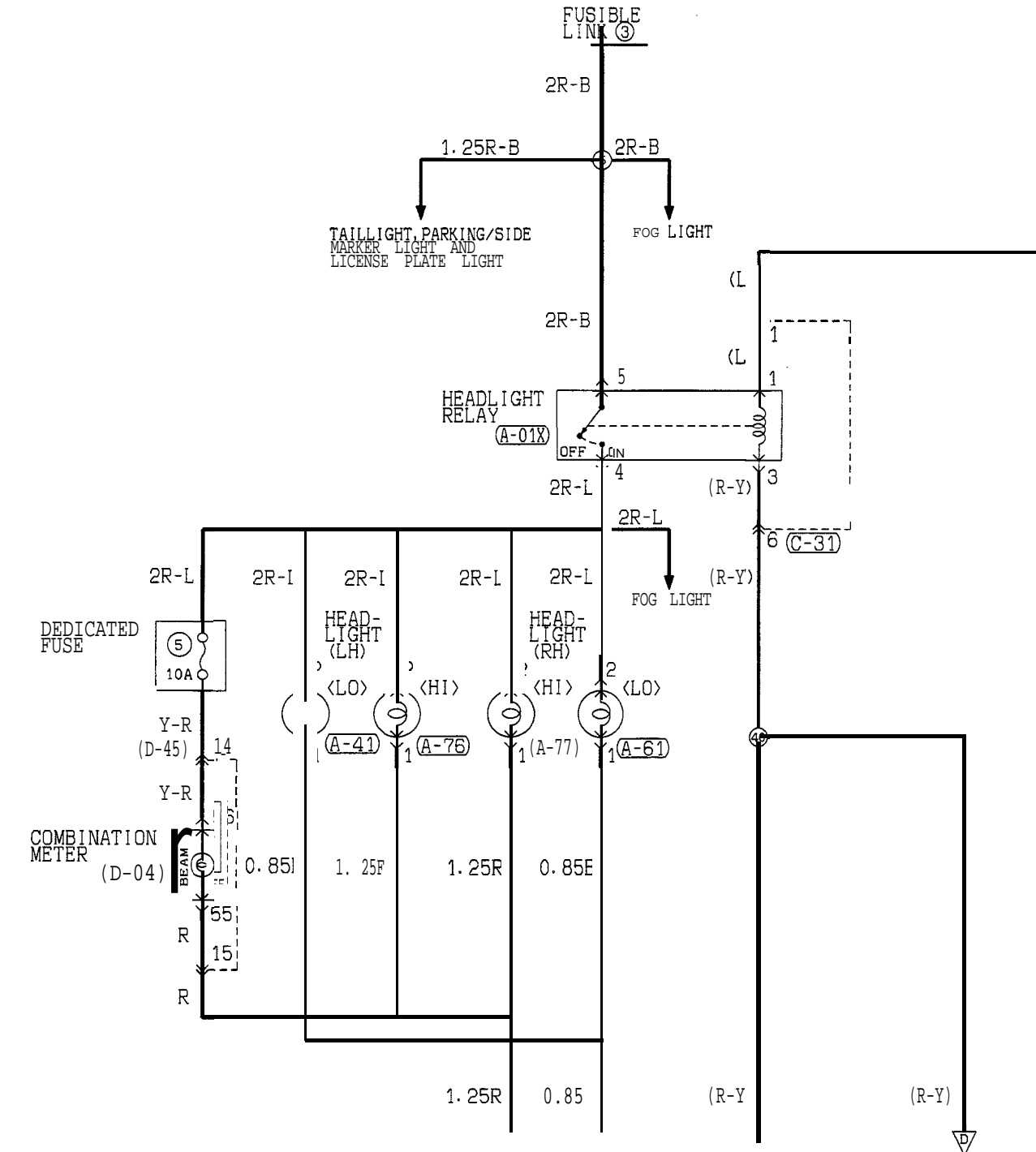

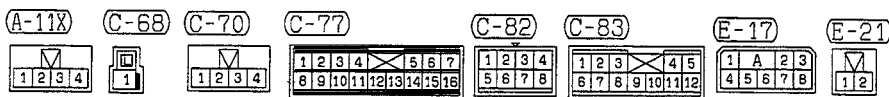
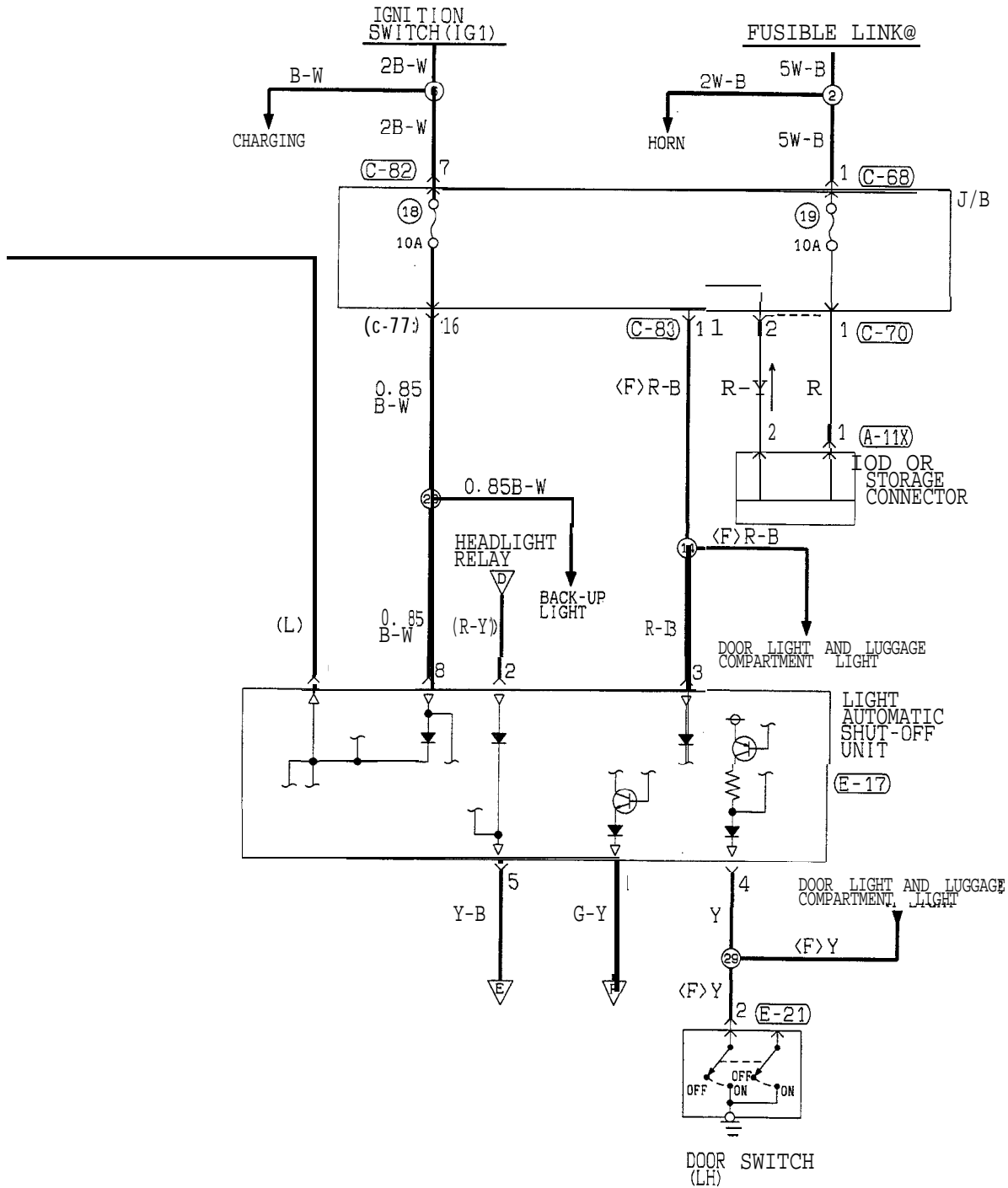

TSB Revision

CIRCUIT DIAGRAM <VEHICLES WITH THEFT-ALARM SYSTEM (FROM 1994 MODELS)> (CONTINUED)

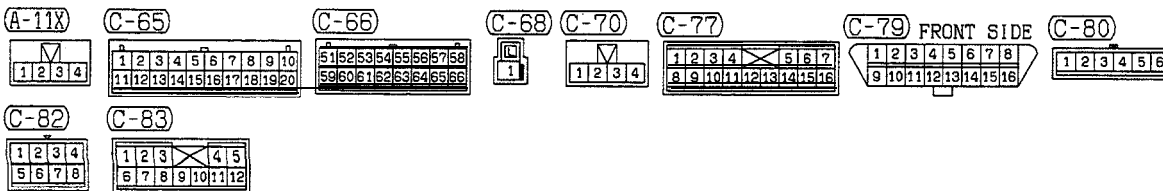
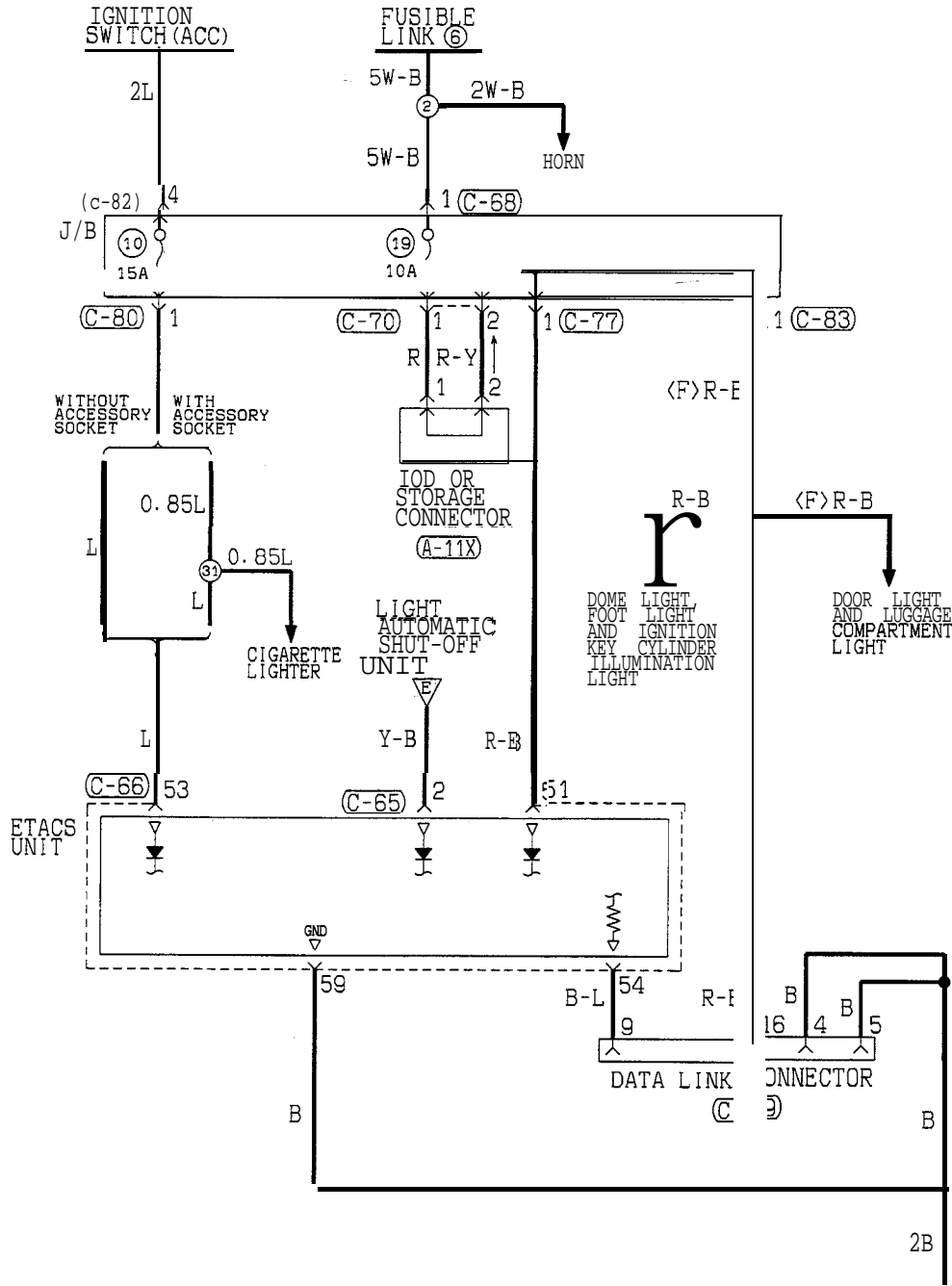

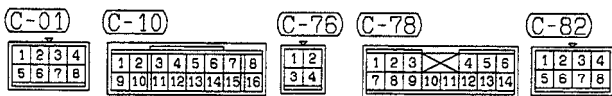
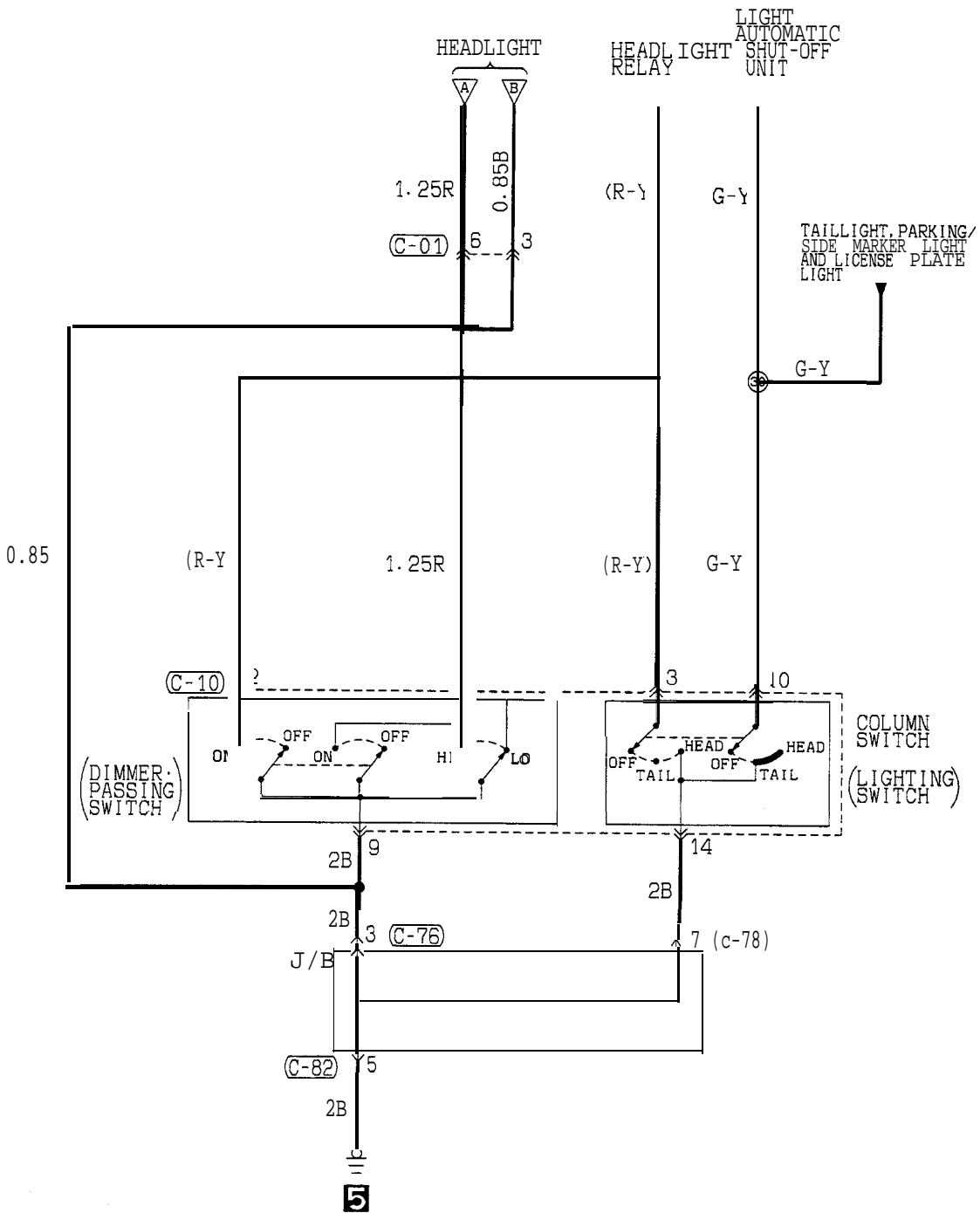

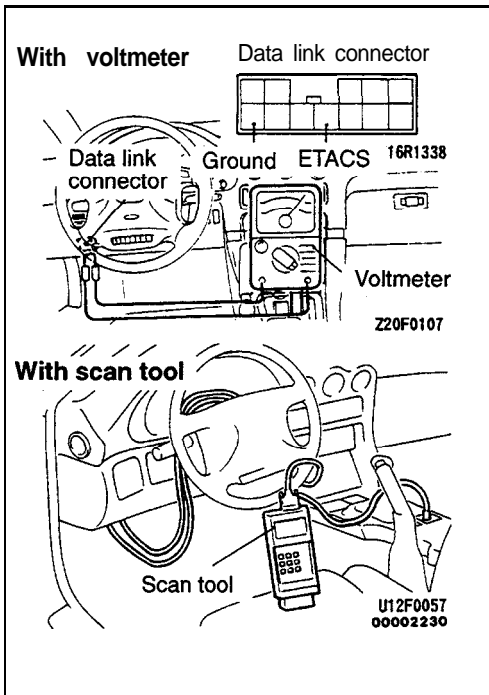
**INPUT SIGNAL****<Up to 1993 models>****When using the scan tool (MUT) or voltmeter**

Using the scan tool or voltmeter, check whether or not the input signals from each switch are being input to the ETACS unit.

- (1) Connect the scan tool to the data link connector located at the right side of the junction block or connect the voltmeter between the ETACS terminal and the ground terminal.
- (2) Check if the buzzer of the scan tool sounds or the needle of the voltmeter moves when each switch is operated. If the buzzer sounds or the needle moves, the input signals are being input to the ETACS unit, so that switch can be considered to be functioning normally. If not, the switch or switch input circuit is faulty. Check the switch and the switch input circuit.

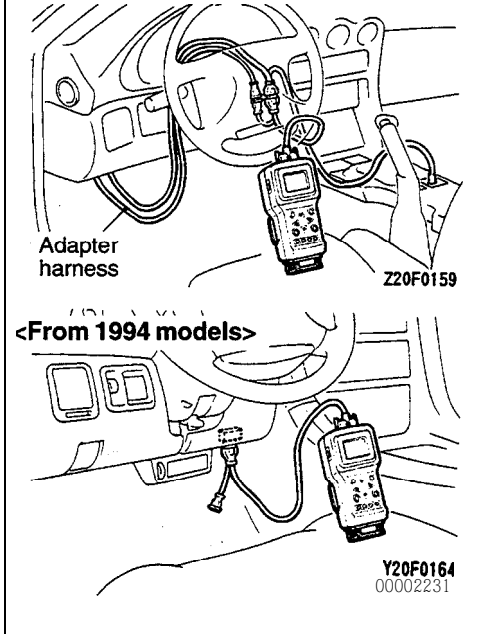
**When using the MUT-II  
<Up to 1993 models>****<All models>****When using the scan tool (MUT-II)**

- (1) Connect the scan tool to the data link connector. When connecting the scan tool to a vehicle up to 1993 models, use the adapter harness supplied together.

**Caution**

**Turn off the ignition switch beforehand whenever the scan tool is connected or disconnected.**

- (2) If the scan tool makes a peep sound when each switch is operated (turned ON/OFF), the input signal to ECU is normally sent from the switch circuit system.

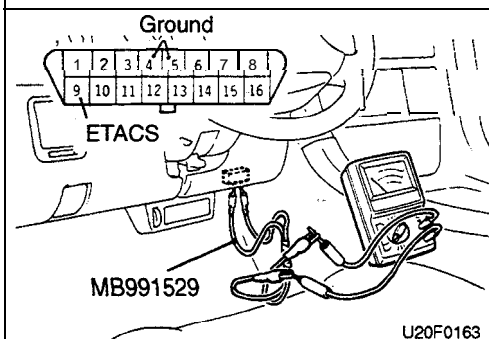
**<From 1994 models>****When using the voltmeter**

- (1) Connect a voltmeter to the ETACS terminal and the ground terminal of the data link connector using the special tool.
- (2) If the voltmeter pointer deflects once when each switch is operated (turned ON/OFF), the input signal to ECU is normally sent from the switch circuit system.

---

NOTES

FOG LIGHT CIRCUIT  
CIRCUIT DIAGRAM (UP TO 1993 MODELS)

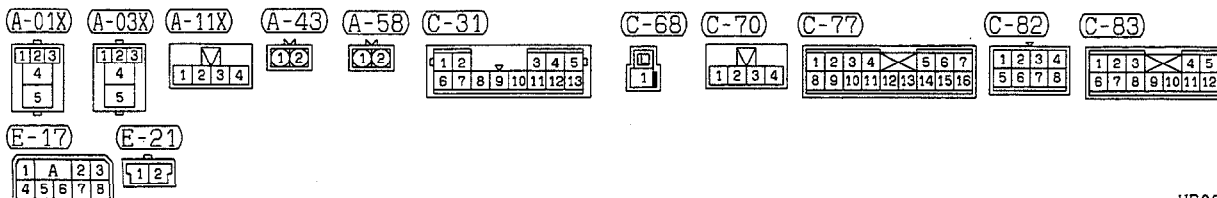
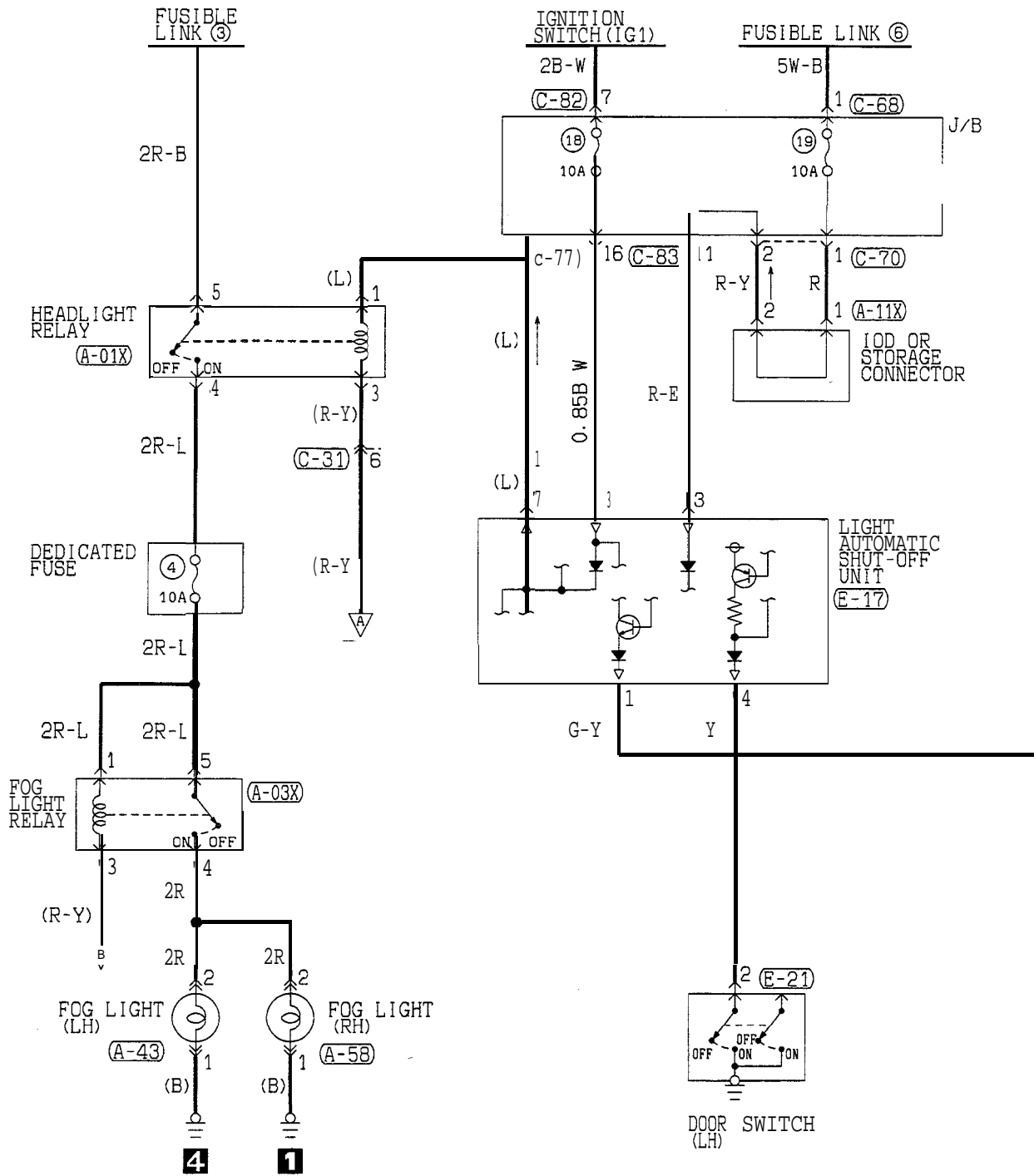

TSB Revision

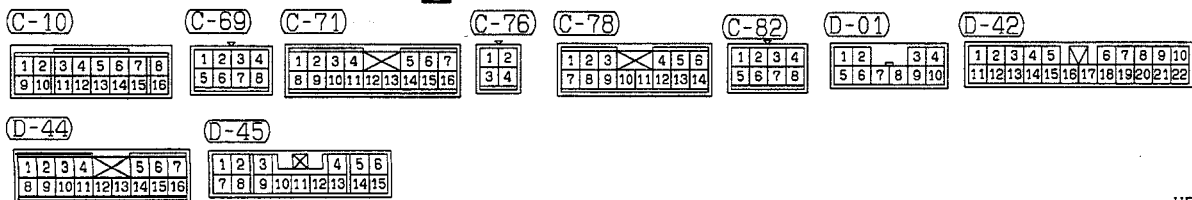
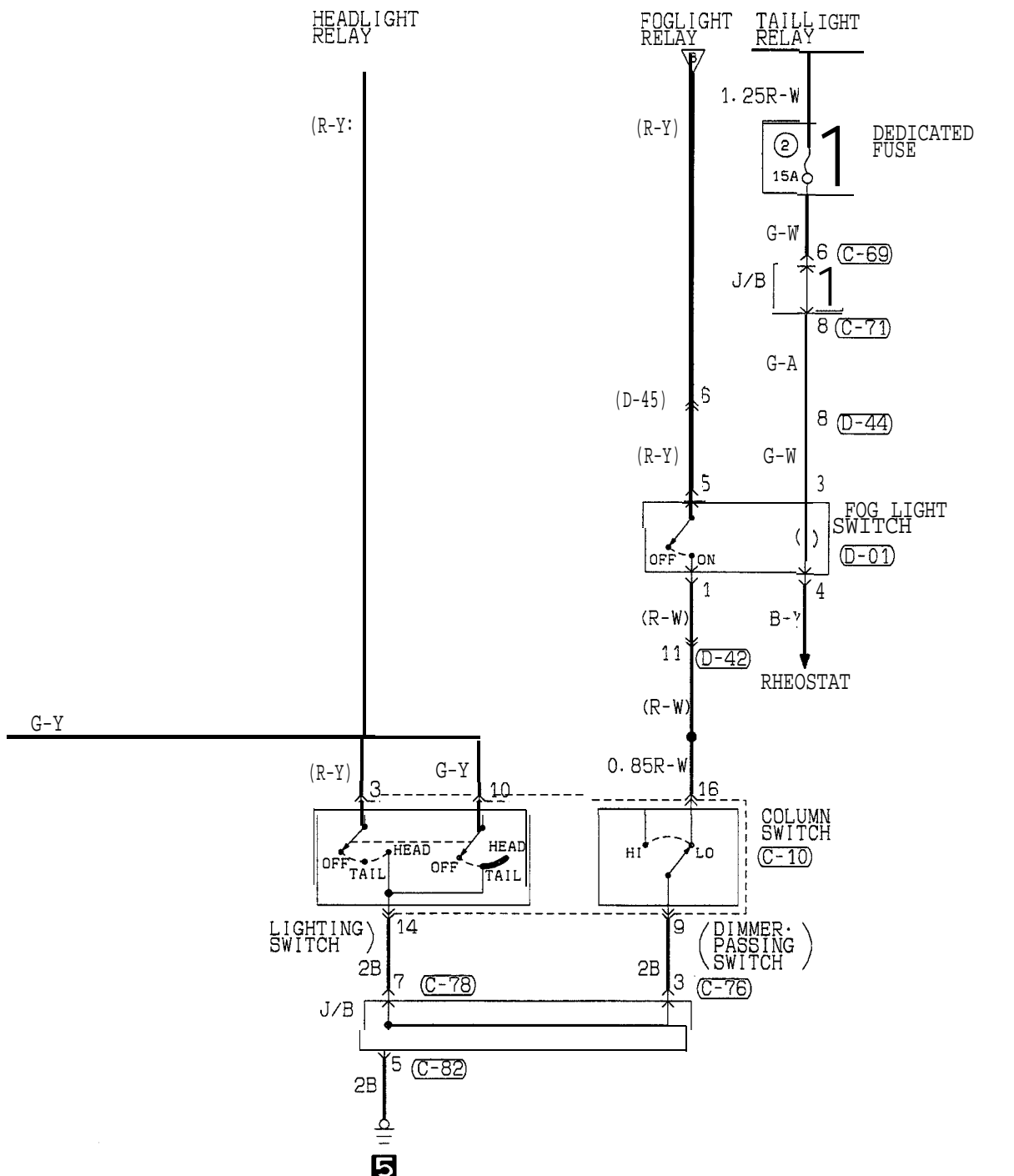

HR08M07AB

TSB Revision



CIRCUIT DIAGRAM (FROM 1994 MODELS)

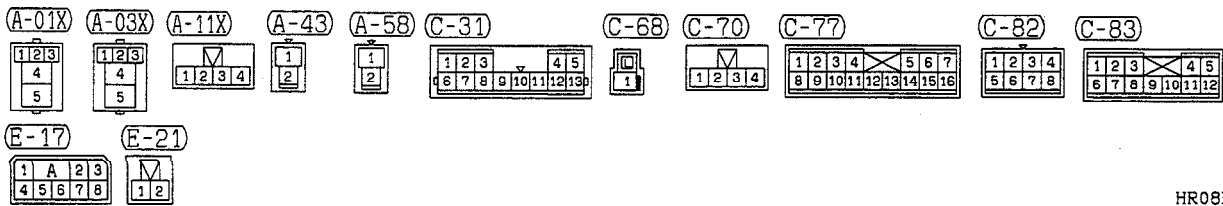
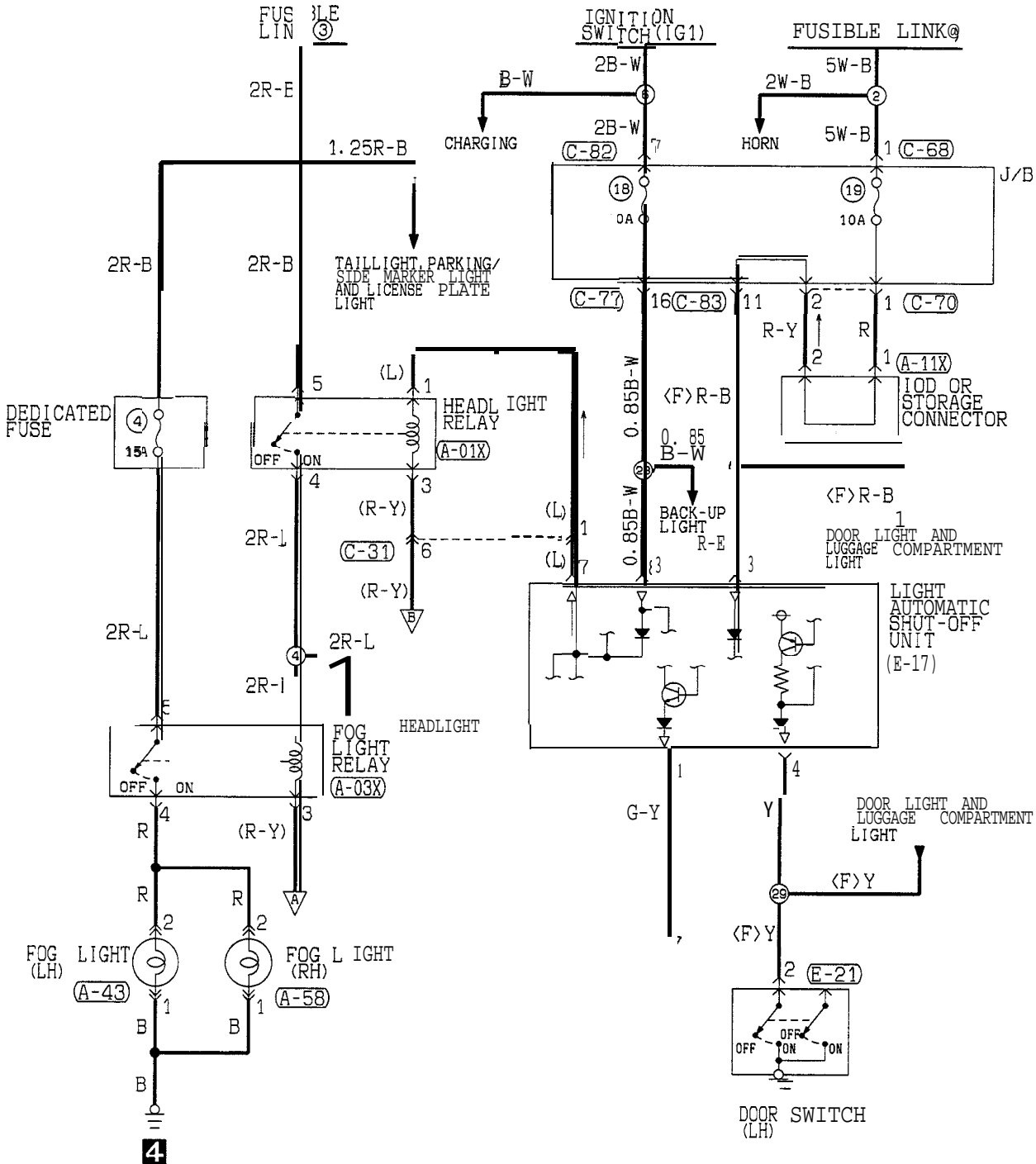

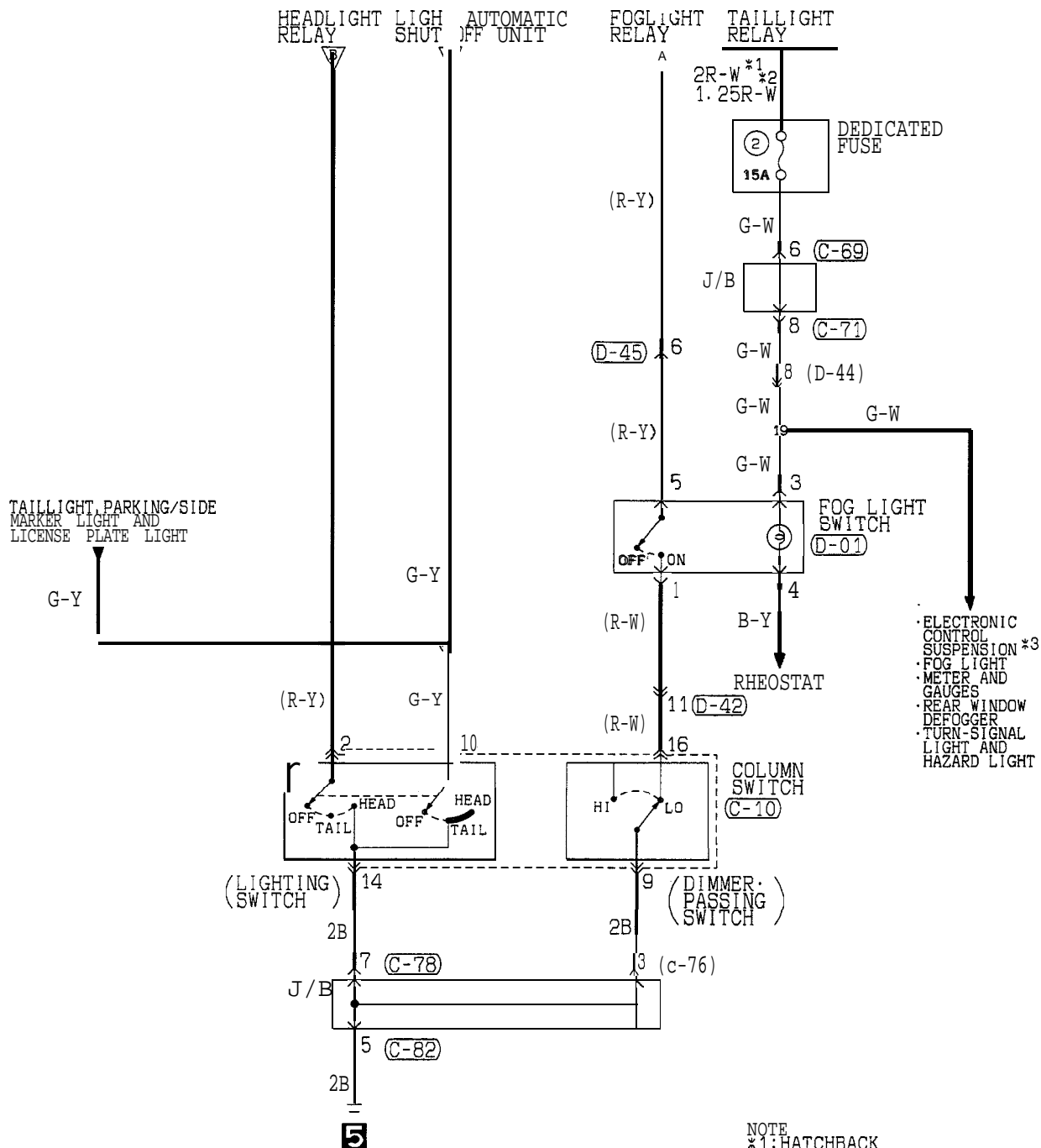

NOTE  
 \*1: HATCHBACK  
 \*2: CONVERTIBLE  
 \*3: UP TO 1995 MODELS

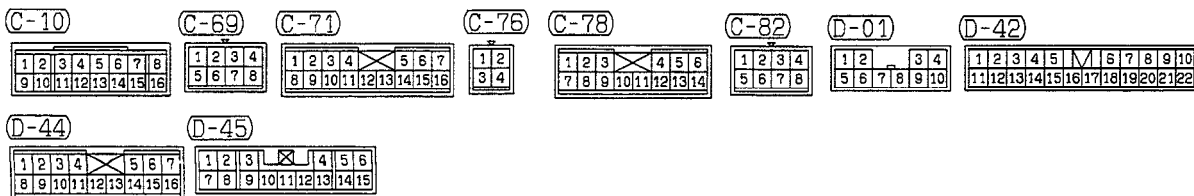

**OPERATION**

- When the fog light switch is placed in the ON position with the lighting switch in the HEAD position and the dimmer switch in the LO position, current flows through the dedicated fuse (4) to the coil of the fog light relay, the fog light switch, the dimmer switch and ground, causing the contacts of the fog light relay to close.  
When the contacts of the fog light relay close, current flows through the dedicated fuse (4) to the contacts of the fog light relay, the fog lights and ground, causing the fog lights to come on.
- When the dimmer switch is placed in the HI position or the lighting switch is placed in the TAIL or OFF position while the fog lights are ON, current supply to the fog light relay or headlight relay is cut off. As a result, the contacts of the fog light relay open, and the fog lights go out.

**NOTE**

The fog lights are included in the light automatic shut-OFF system. (Refer to P.54-37). The indicator lights are also included in the same system.

**Fog Lights Operation Conditions**

Fog light switch	Lighting switch	Dimmer switch	Fog lights
ON position	OFF position or TAIL position	LO position	OFF
		HI position	OFF
	HEAD position	LO position	ON
		HI position	OFF

**TROUBLESHOOTING HINTS**

1. The right or left fog lights only go on.
  - Check the bulb.
2. Fog lights do not go on when the fog light switch is set at ON.
  - Check the dedicated fuse (4).
  - Check the fog light relay. (Refer to P.54-108).
  - Check the fog light switch.

**NOTE**

For the light automatic shut-OFF system troubleshooting hints, refer to P.54-38.

COMPONENT LOCATION

Headlight relay / Foglight relay

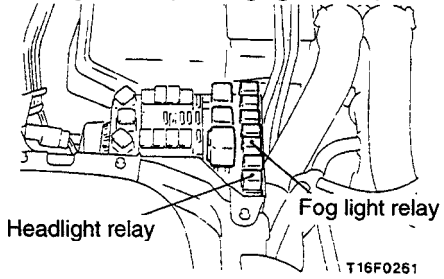

Light automatic shut-off unit  
<Vehicles without keyless entry system>

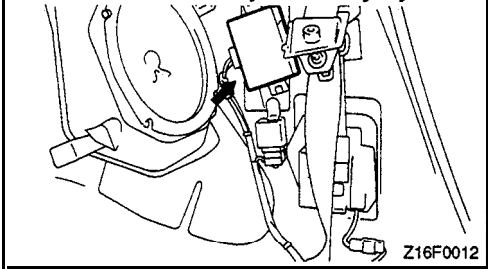

Light automatic shut-off unit  
<Vehicles with keyless entry system>

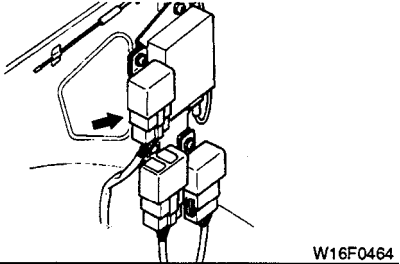

TAIL LIGHT, PARKING/SIDE MARKER LIGHT AND LICENSE PLATE LIGHT  
CIRCUIT DIAGRAM (UP TO 1993 MODELS)

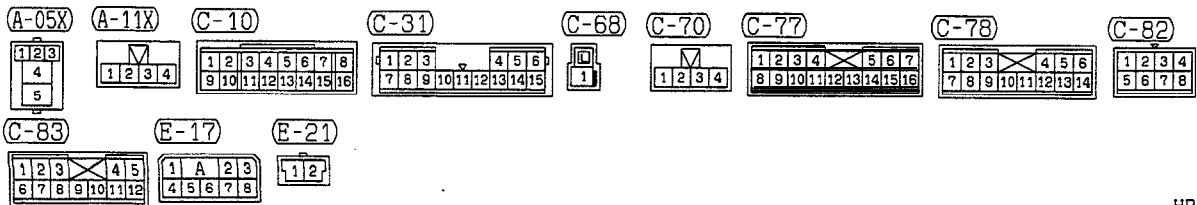
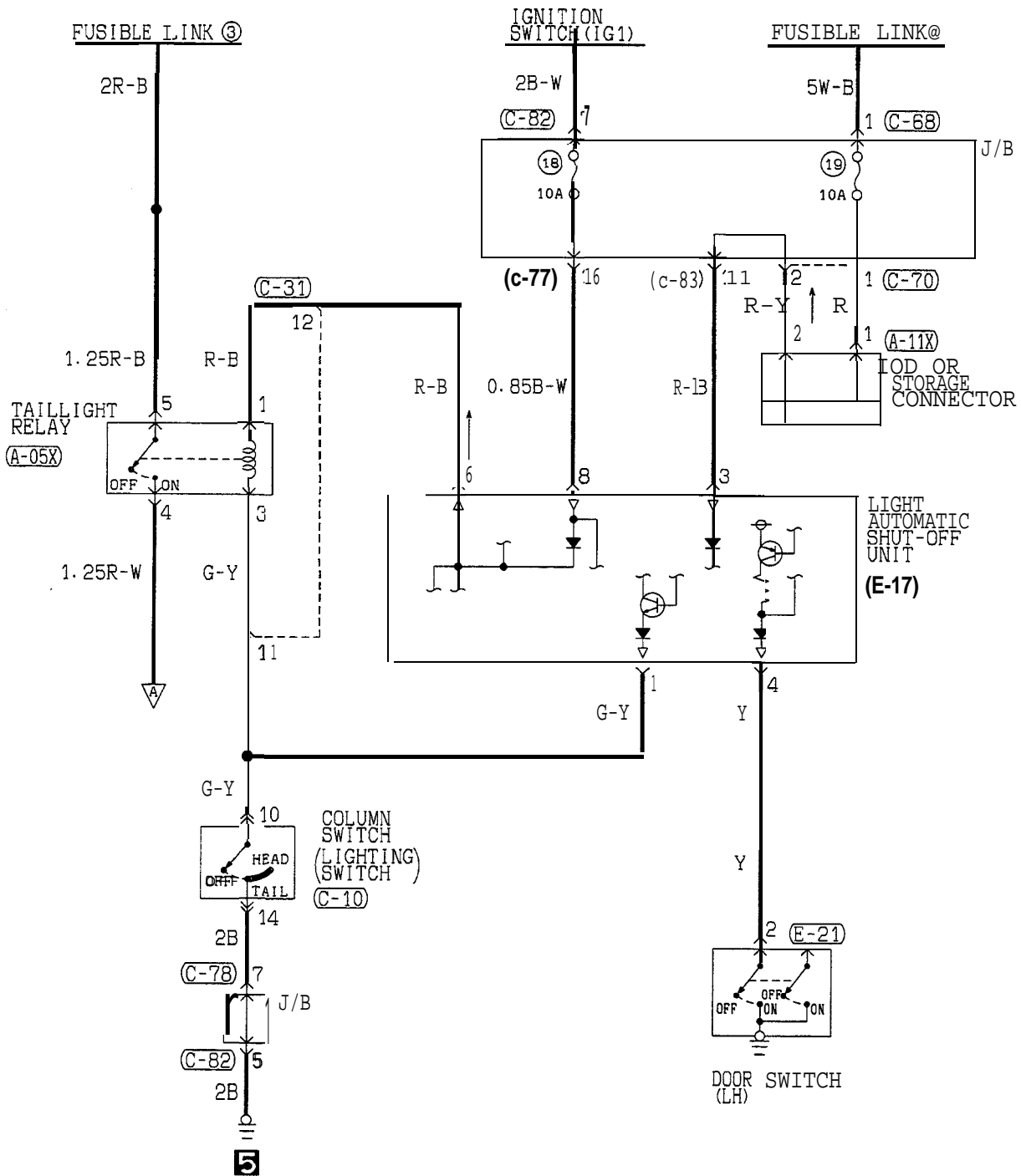

TSB Revision

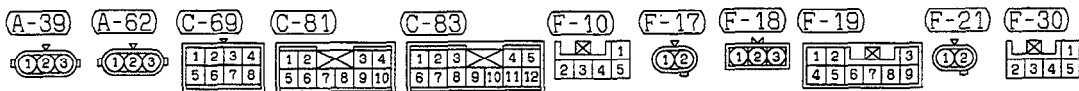
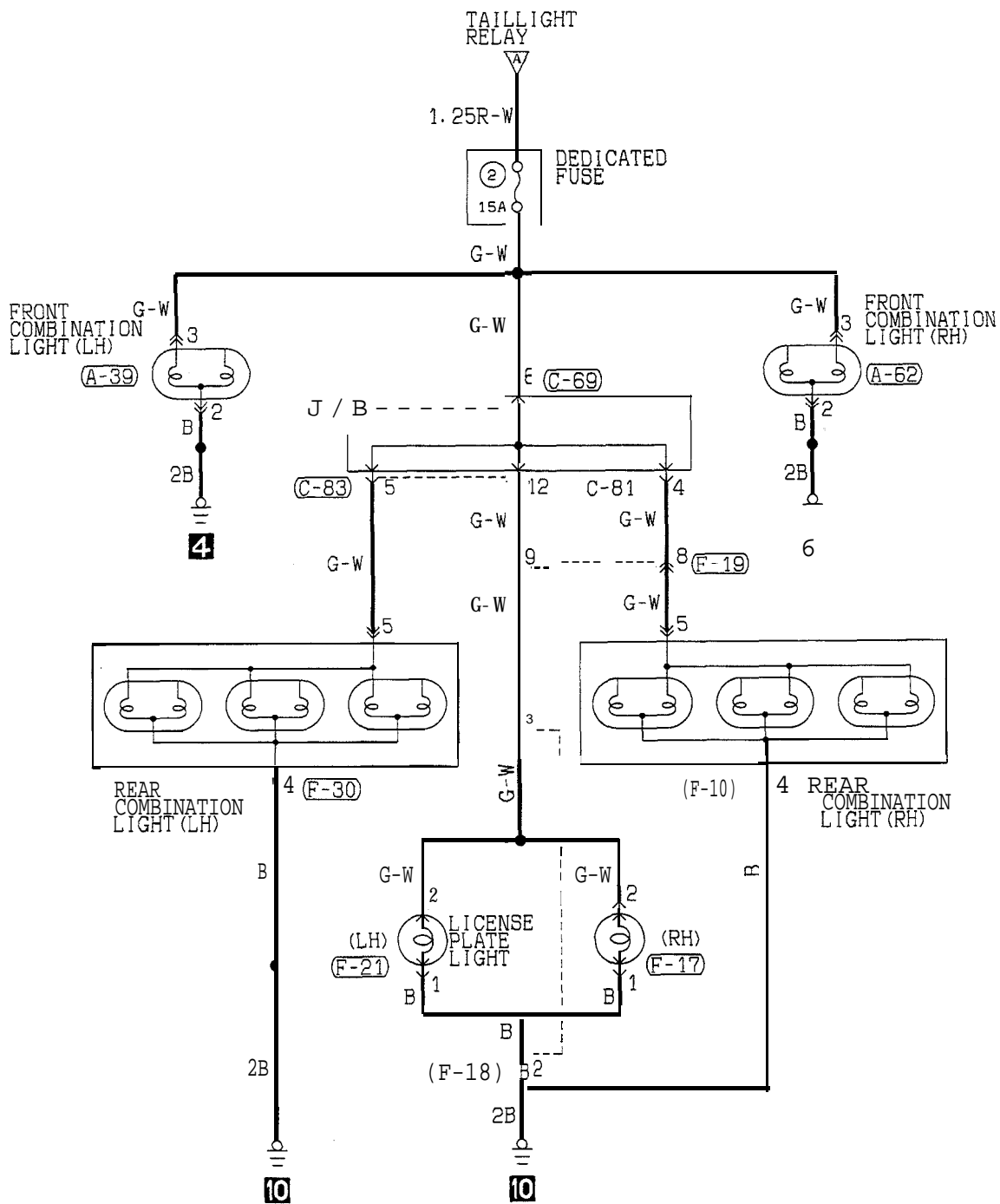

CIRCUIT DIAGRAM <HATCHBACK> (FROM 1994 MODELS)

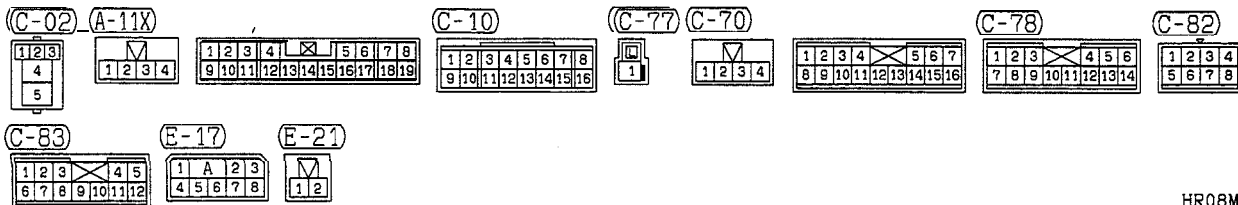
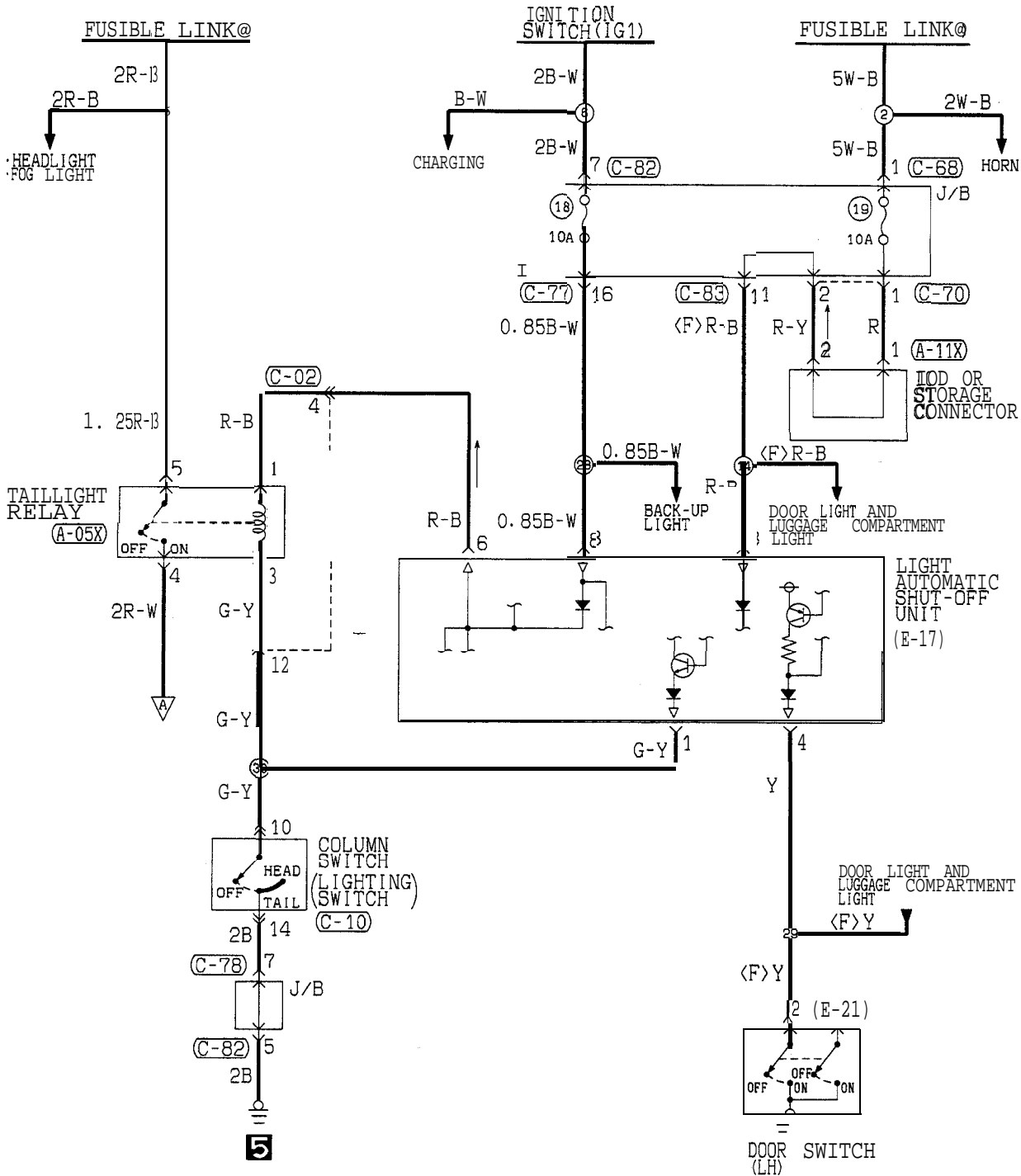

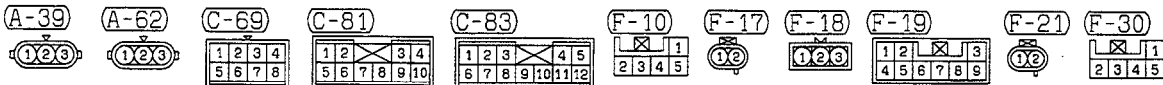
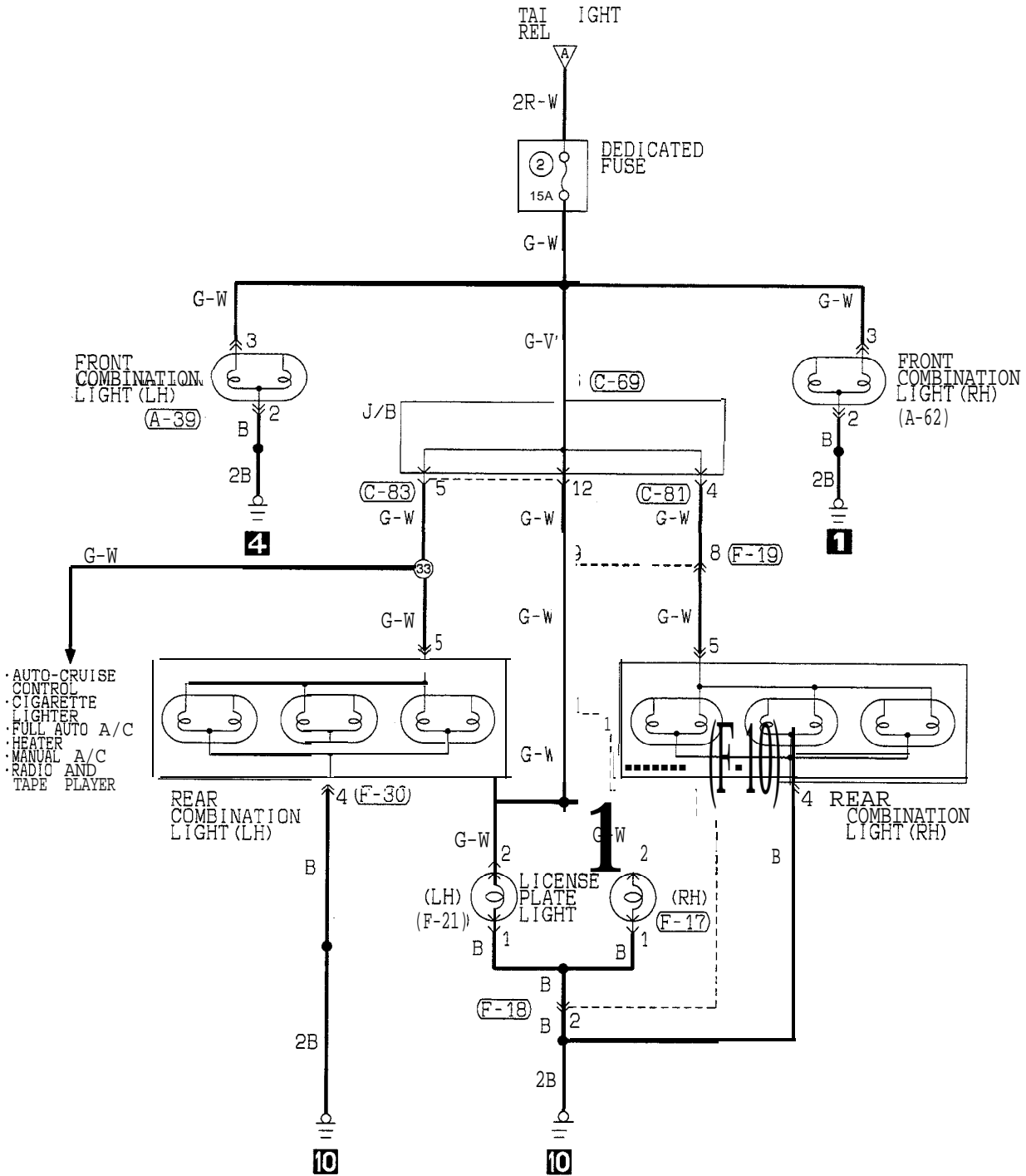



CIRCUIT DIAGRAM <CONVERTIBLE> (FROM 1995 MODELS)

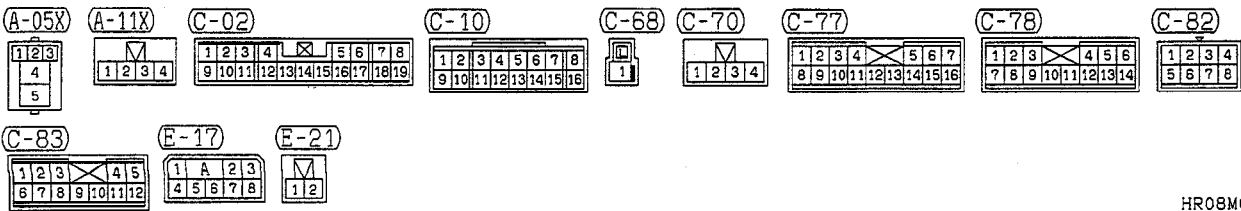
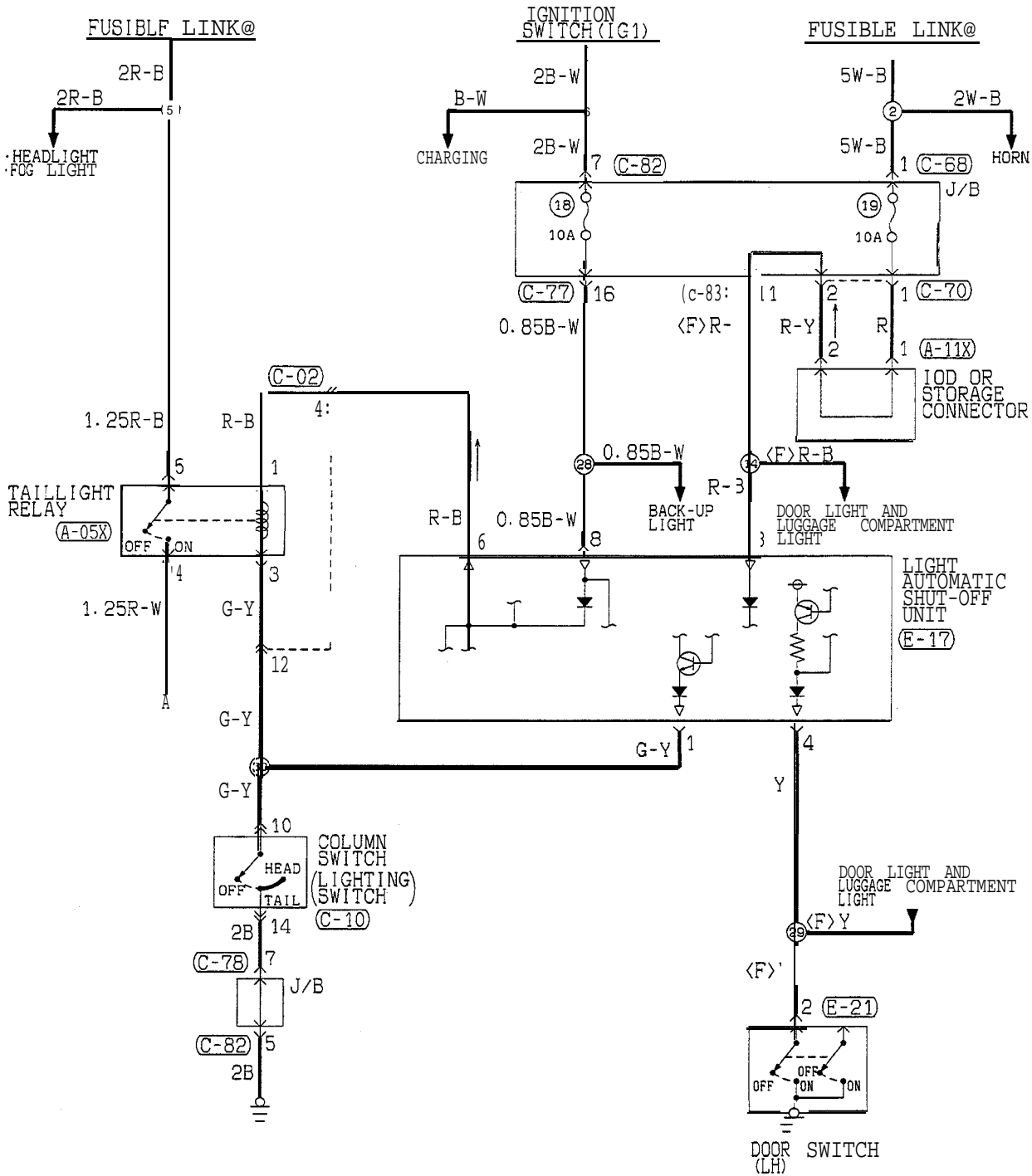

HR08M06AA

TSB Revision

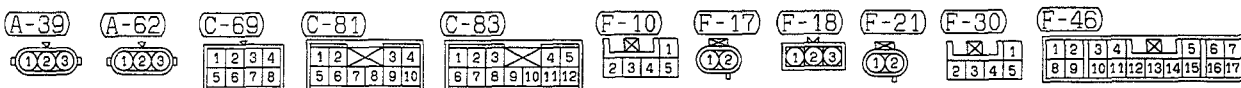
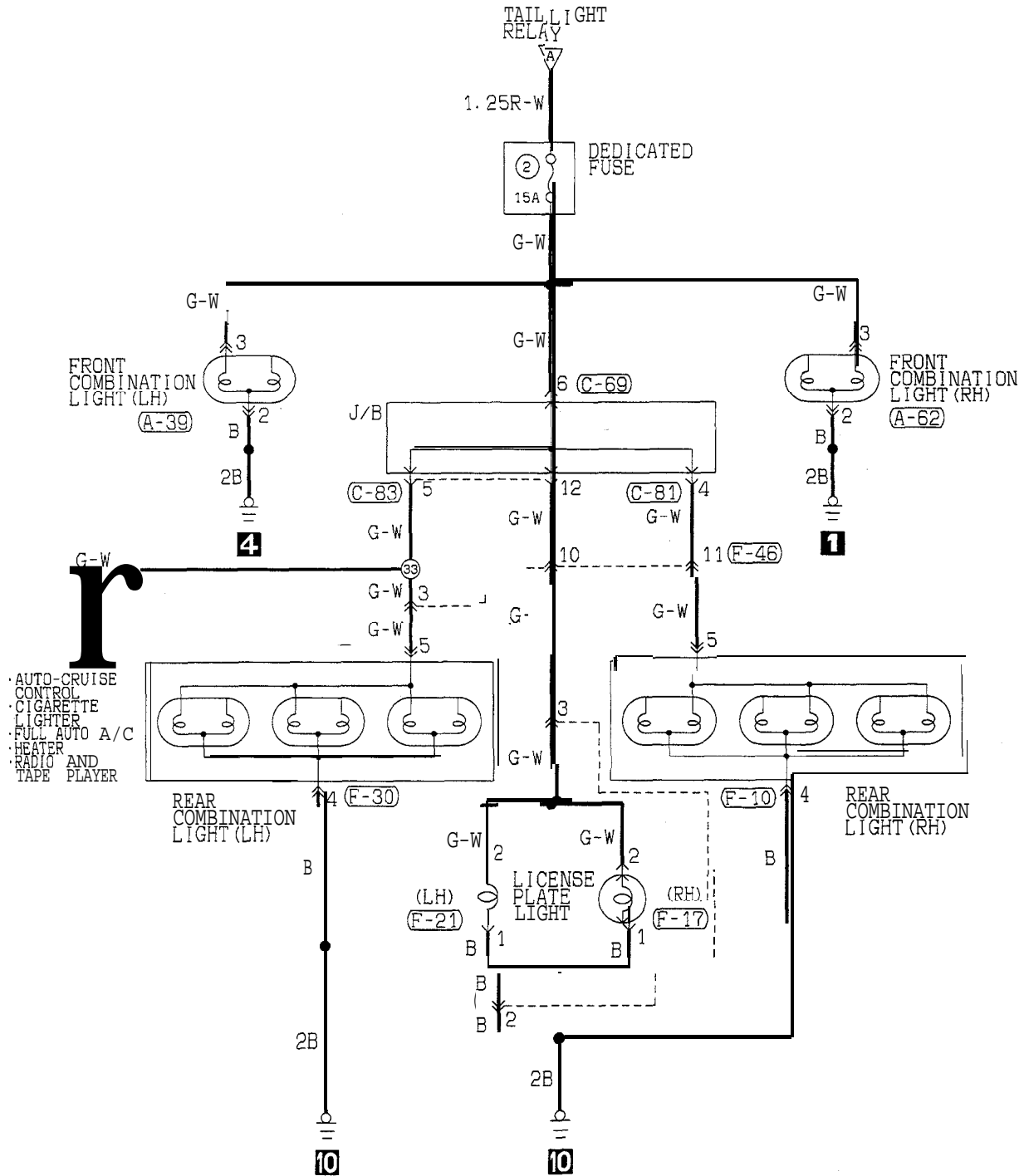

HR08M06AB

TSB Revision

**OPERATION**

- When the lighting switch is placed in the TAIL or HEAD position, current flows through the coil of the tail light relay to the lighting switch and ground, causing the contacts of the tail light relay to close. Then current flows through the contacts of the tail light relay to the dedicated fuse (2), the individual lights and ground, causing the tail lights, parking/side marker lights and license plate lights to go ON.

**<Light automatic shut-OFF system>**

- If the driver's door is opened after the ignition switch is turned to "OFF" or the ignition switch is turned to "OFF" after the driver's door is opened when the tail lights are lit, the current which flows to the coil side of the tail light relay will be cut off by the light automatic shut-off unit opening the contact point, and the tail light relay will be turned "OFF" to automatically shut off the tail lights, parking and front side marker lights and license plate light.
- To turn on the tail lights, parking and front side marker lights and license plate light again after they are automatically shut off, turn the lighting switch to "OFF" once and to "HEAD" again, or turn the ignition switch to "ACC" or "ON", and the automatic shut-OFF will be cancelled and the current will flow from the light automatic shut-OFF unit to the coil side of the tail light relay to close the contact point. Thus, the tail light relay will be turned "ON" to turn on the tail lights, parking and front marker lights and license plate light.

**NOTE**

When the lighting switch is at the "HEAD" position, the light automatic shut-OFF system will be also activated for the headlights. (Refer to P.54-37.) The same system will also be activated for the illumination lights, etc.

**TROUBLESHOOTING HINTS**

1. All lights don't illuminate.
  - (1) The headlights don't illuminate, either.
    - Check the fusible link (3).
  - (2) The headlights illuminate.
    - Check the tail light relay. (Refer to P.54-108.)
    - Check the dedicated fuse (2).
    - Check the lighting switch. (Refer to P.54-113.)
    - Check the light automatic shut-OFF unit. (Refer to P.54-108.)
2. Some light does not come on.
  - Check the bulb.
  - Check the grounding circuit.
3. Some light is not automatically shut off.
  - Check the driver's side door switch. (Refer to GROUP 42 – Door Assembly.)
  - Check the automatic shut-OFF unit. (Refer to P.54-108.)

COMPONENT LOCATION

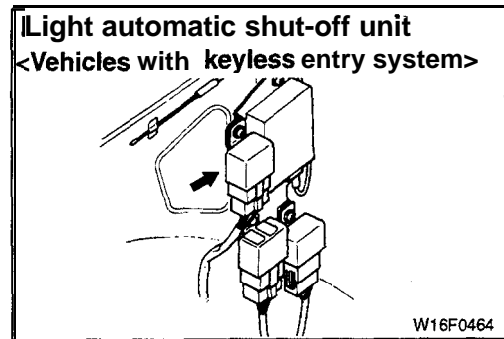
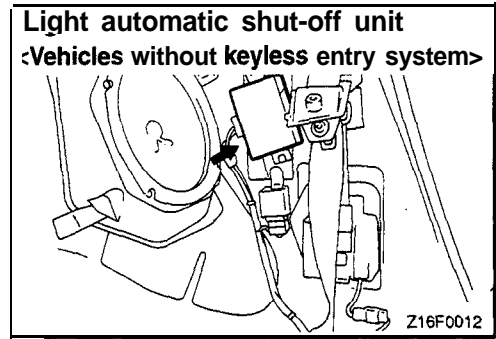
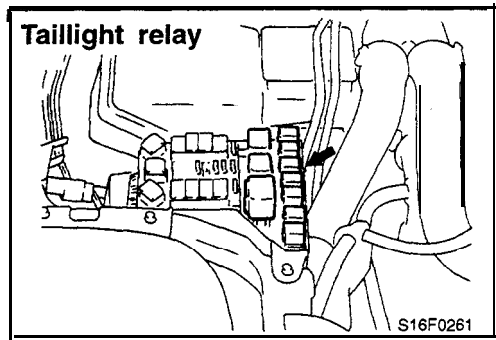

DOME LIGHT, FOOT LIGHT AND IGNITION KEY CYLINDER ILLUMINATION LIGHT  
CIRCUIT DIAGRAM (UP TO 1993 MODELS)

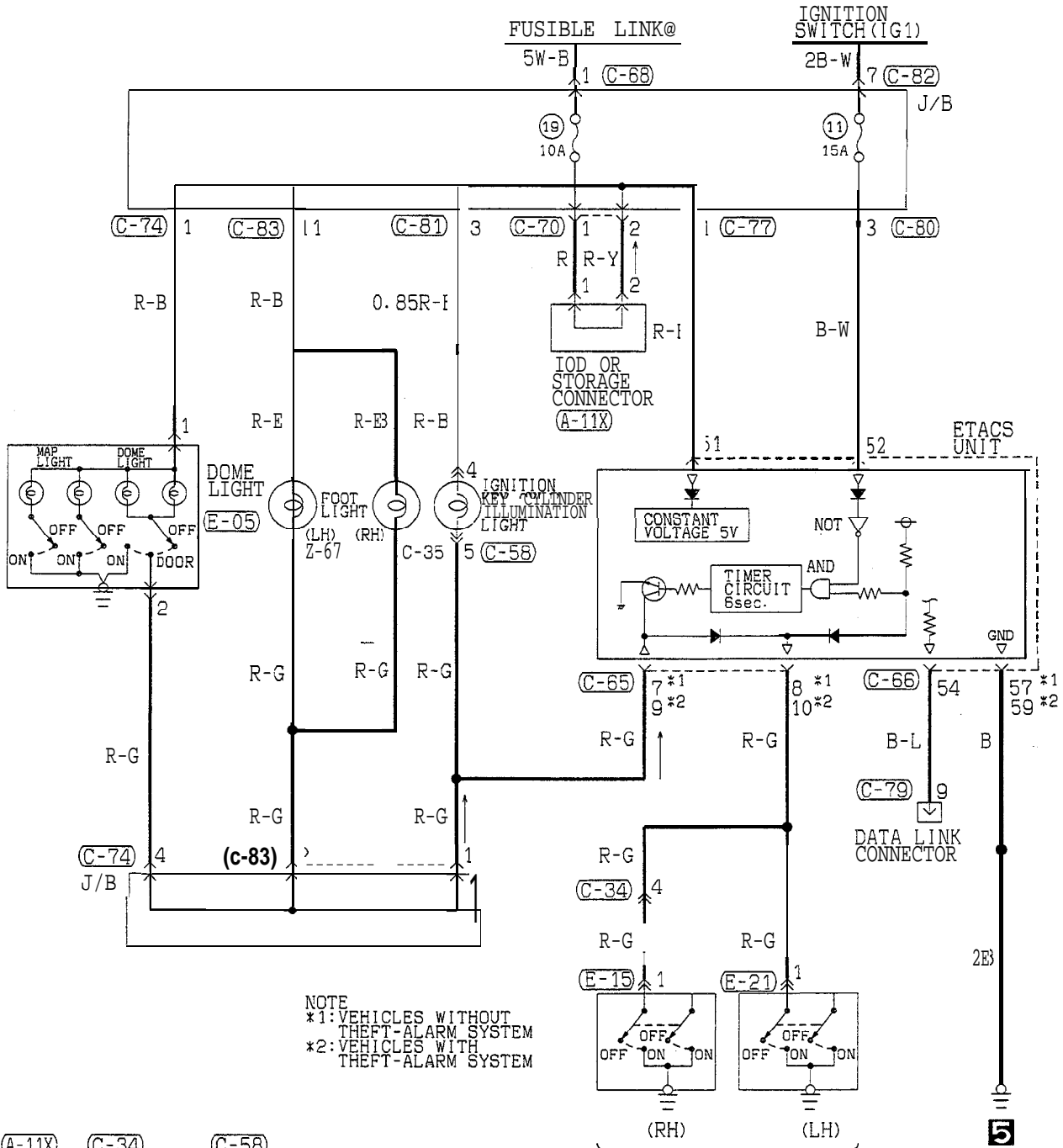

NOTE  
\*1: VEHICLES WITHOUT THEFT-ALARM SYSTEM  
\*2: VEHICLES WITH THEFT-ALARM SYSTEM

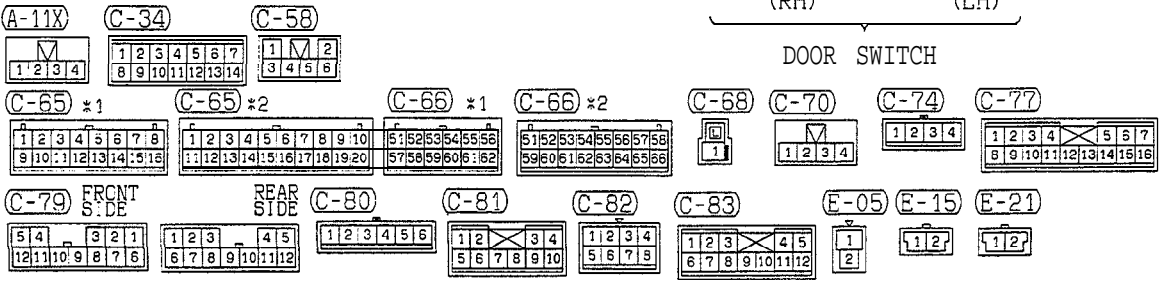

CIRCUIT DIAGRAM (1994 MODELS)

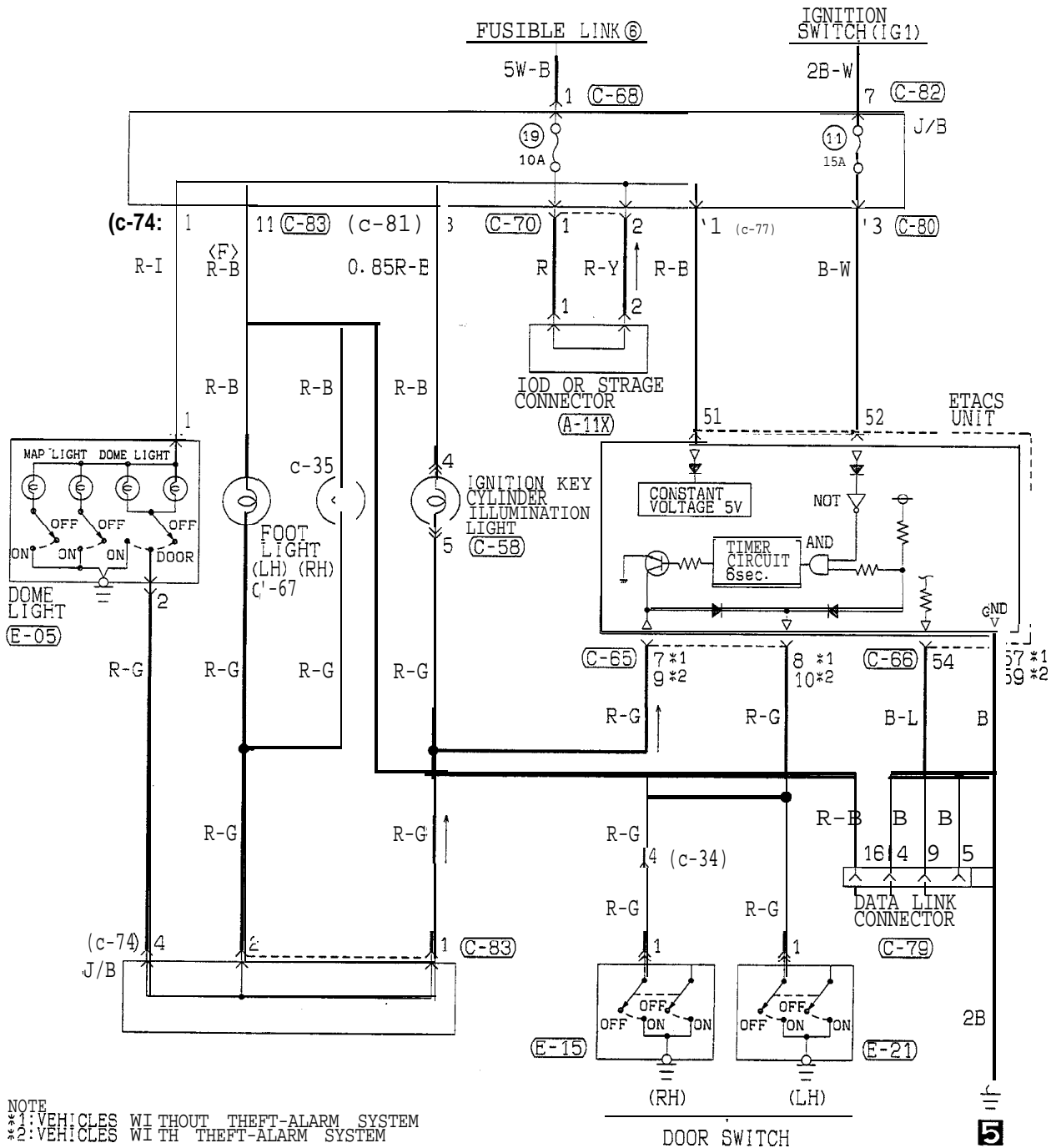

NOTE  
 \*1: VEHICLES WITHOUT THEFT-ALARM SYSTEM  
 \*2: VEHICLES WITH THEFT-ALARM SYSTEM

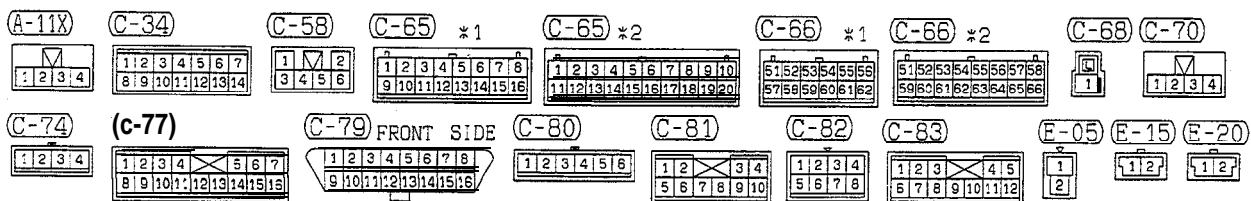

HR08M11 AA

TSB Revision

CIRCUIT DIAGRAM <HATCHBACK> (FROM 1995 MODELS) AND <CONVERTIBLE> (1995 MODELS)

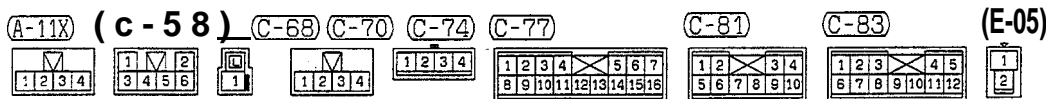
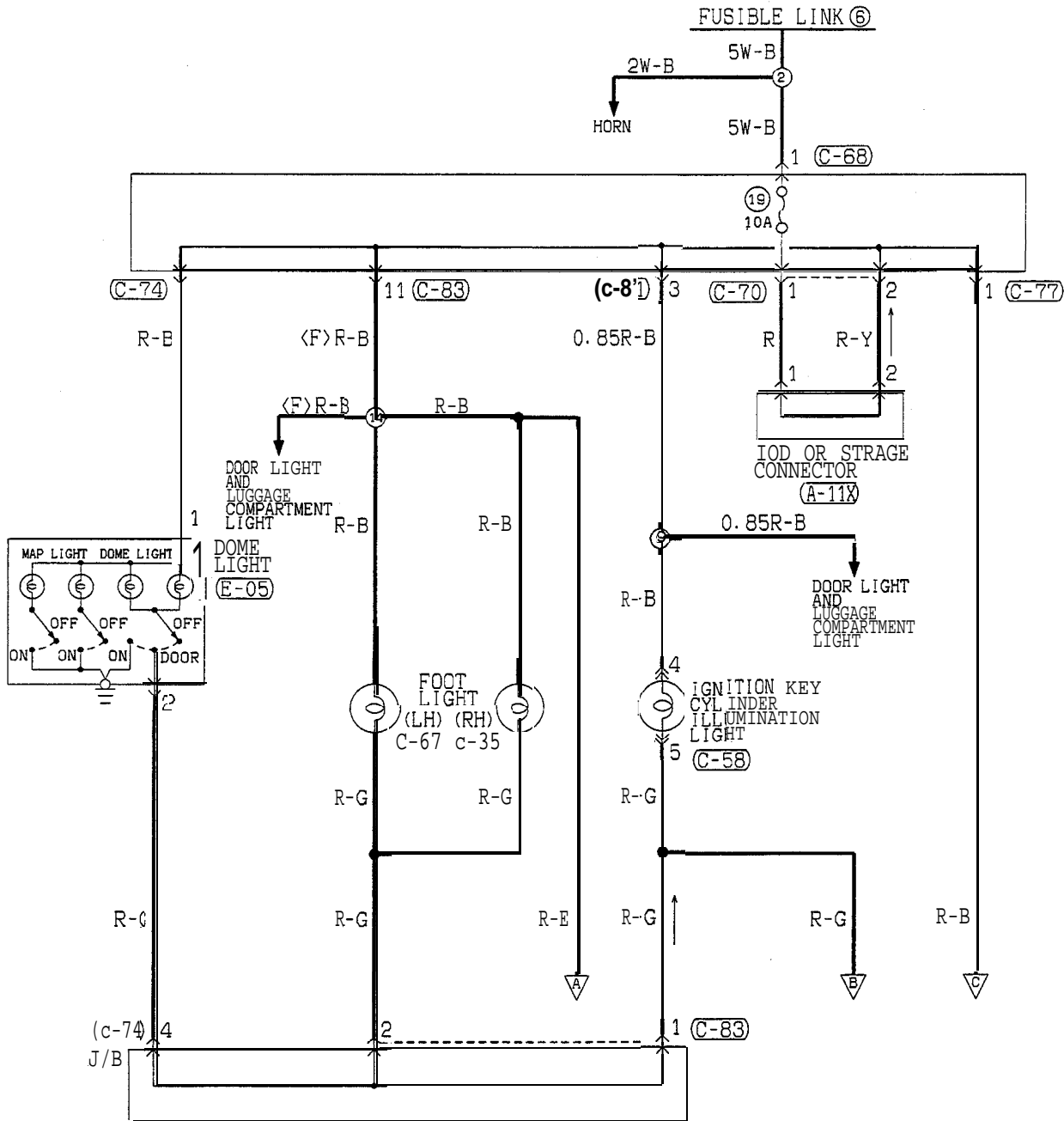

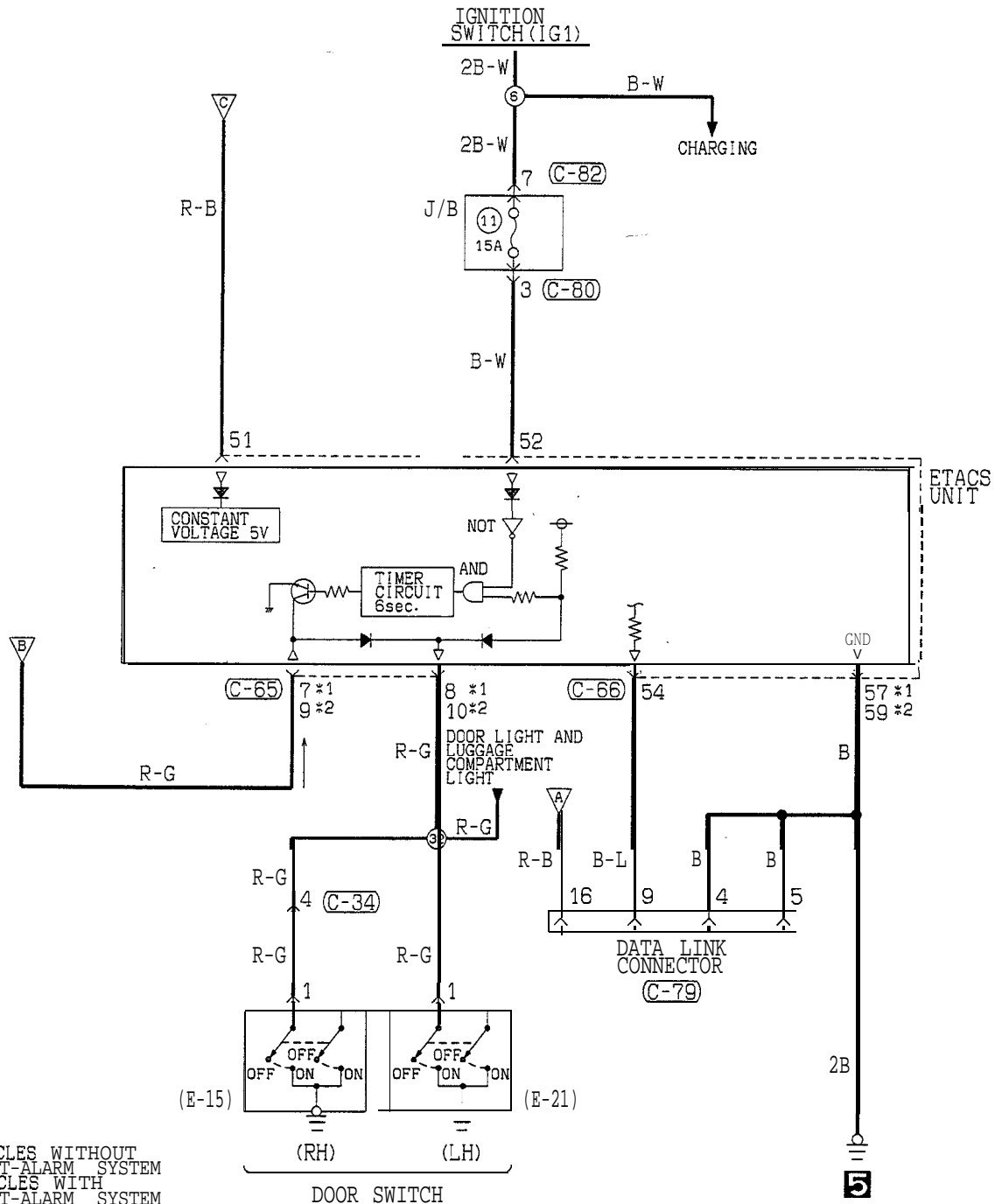

NOTE  
 \*1: VEHICLES WITHOUT THEFT-ALARM SYSTEM  
 \*2: VEHICLES WITH THEFT-ALARM SYSTEM

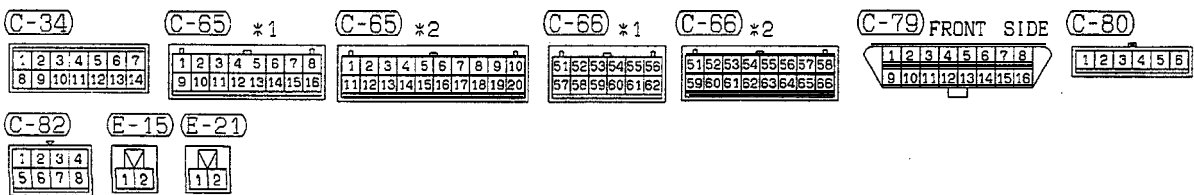

HR08M12AB

TSB Revision



CIRCUIT DIAGRAM <CONVERTIBLE> (FROM 1996 MODELS)

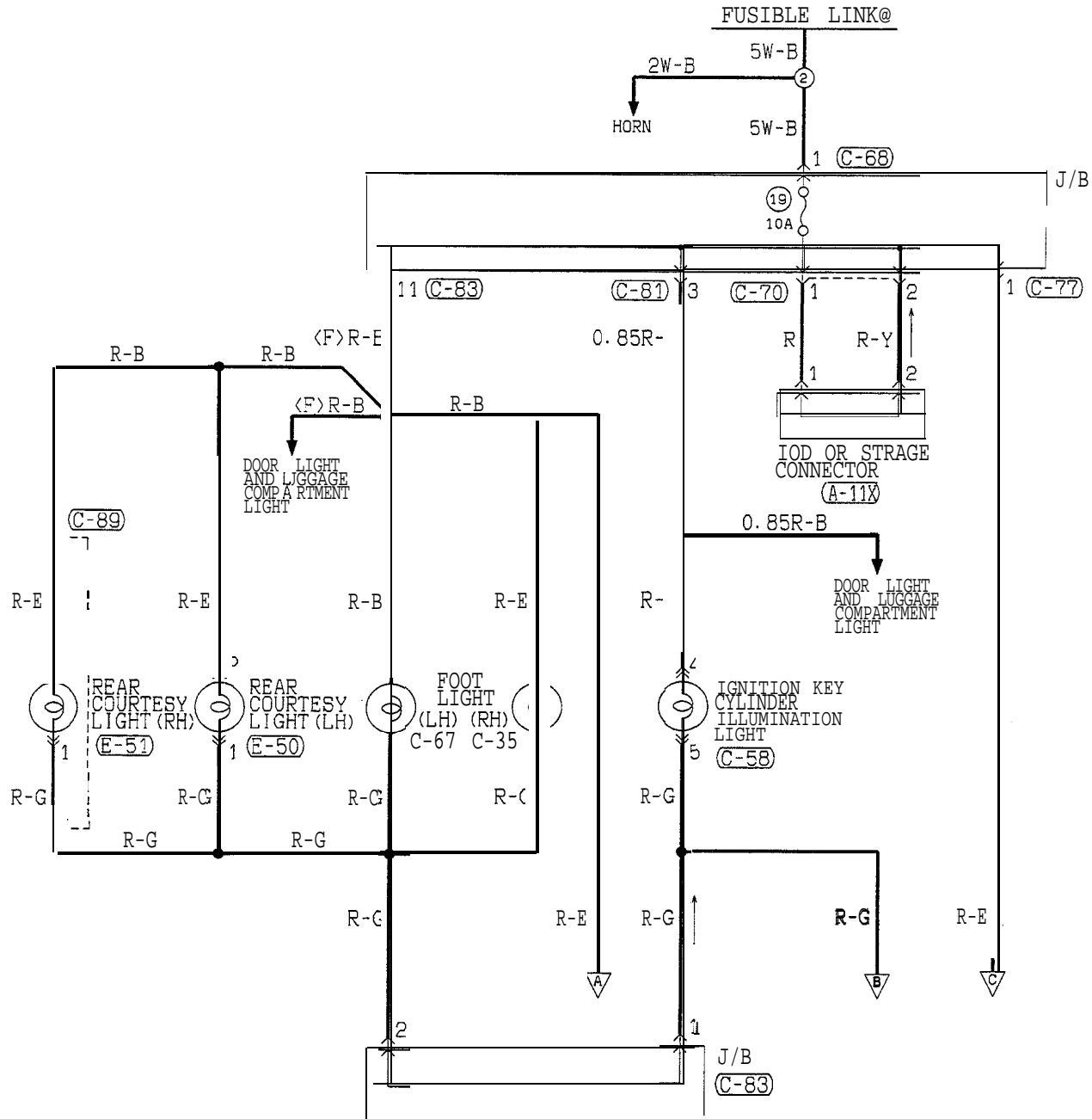

- (A-11X)
- (C-58)
- (C-68)
- (C-70)
- (C-77)
- (C-81)
- (C-83)
- (C-89)
- (E-50)
- (E-51)

TSB Revision

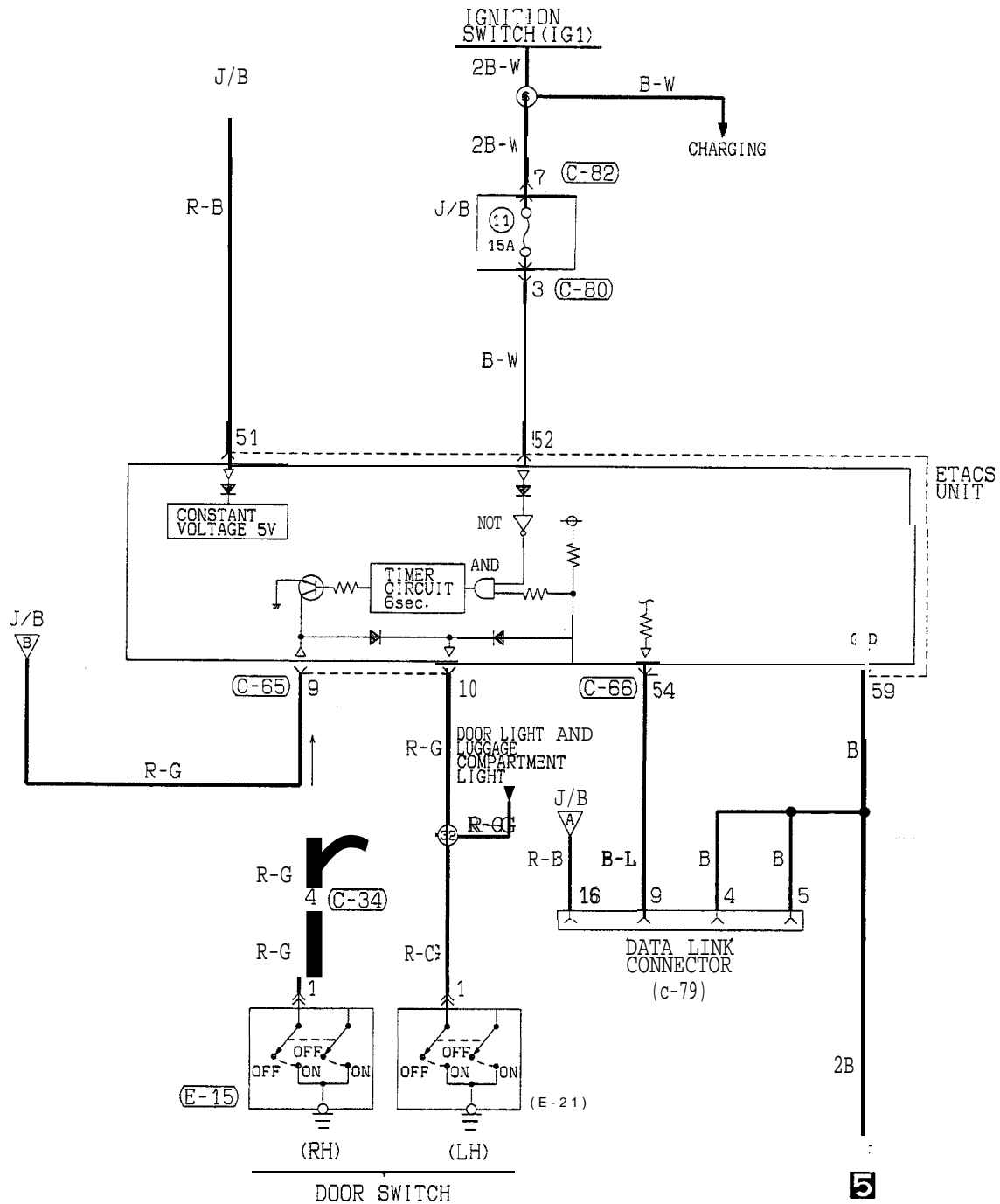

**C-34**

1	2	3	4	5	6	7
8	9	10	11	12	13	14

**(c-651)**

1	2	3	4	5	6	7	8	9	10
11	12	13	14	15	16	17	18	19	20

**C-66**

51	52	53	54	55	56	57	58
59	60	61	62	63	64	65	66

**C-79 FRONT SIDE**

1	2	3	4	5	6	7	8
9	10	11	12	13	14	15	16

**C-80**

1	2	3	4	5	6
---	---	---	---	---	---

**(c-82)**

1	2	3	4
5	6	7	8

**E-15**

1	2
---	---

**E-21**

1	2
---	---

TSB Revision

**OPERATION**

**<Dome light>**

- Battery voltage is always applied to the dome light. When the dome light switch is turned to “ON”, the dome light will remain lit. After either door is opened if the dome light switch is at “DOOR” position, the dome light will come on.
- With the dome light turned on (with the ignition switch in the OFF position and with the dome light switch in the DOOR position), close all doors, and the timer circuit in the ETACS unit will be activated to gradually vary the voltage for approx. 6 seconds owing to the duty control, and the voltage will be output to transistor Tr. Since the voltage applied to the dome light gradually decreases, the dome light will be dimmed.
- If the ignition switch is turned to “ON” while the dome light is lit (while the timer is activated), the timer circuit will be opened to turn “OFF” transistor Tr. This will immediately turn off the dome light without dimming.

**<Foot lights and ignition key illumination light>**

- Battery voltage is always applied to the foot lights and ignition key illumination light. With the ignition switch in the OFF position, open any door, and all lights will come on.
- With all lights turned on (with the ignition switch in the OFF position), close all doors, and the timer circuit inside the ETACS unit will operate in the same manner as the dome light to dim all lights. When the ignition switch is placed in the ON position with all lights turned on (with the timer in operation), the same operation as the dome light will take place.

**TROUBLESHOOTING HINTS**

Phenomenon		Checking method
Dome light does not come on when a door is opened with the dome light switch in the DOOR position.	The foot lights and ignition key cylinder illumination light don't illuminate, either.	<ul style="list-style-type: none"> <li>• Check the door switch input signal. (Refer to P.54-80.)</li> <li>• Check the door switch. (Refer to GROUP 42 – Door Assembly.)</li> </ul>
	The foot lights and ignition key cylinder illumination light illuminate.	<ul style="list-style-type: none"> <li>• Check the dome light switch.</li> <li>• Check the dome light bulb.</li> </ul>
Dome light, foot lights and ignition key illumination light go out at once when doors are closed.		<ul style="list-style-type: none"> <li>• Check the door switch input signal. (Refer to P.54-80.)</li> </ul>
Even if ignition switch is turned on while lights are being dimmed, lights do not go out at the same time.		<ul style="list-style-type: none"> <li>• Check the ignition switch input signal. (Refer to P.54-80.)</li> </ul>

**COMPONENT LOCATION**

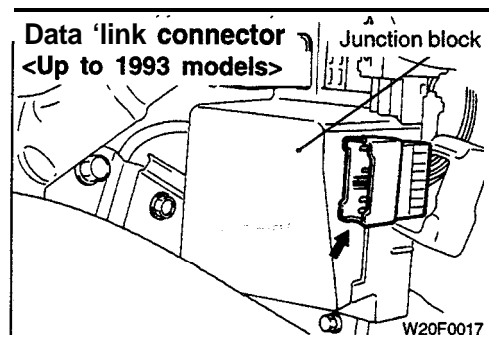
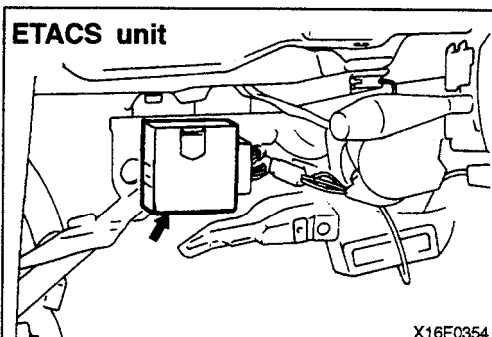

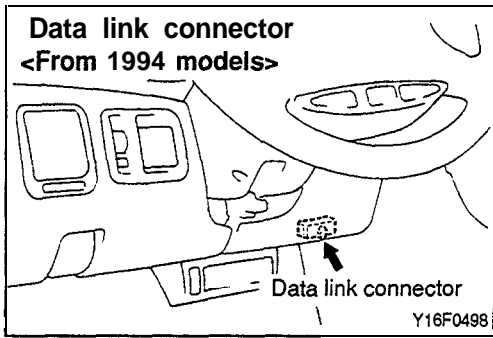

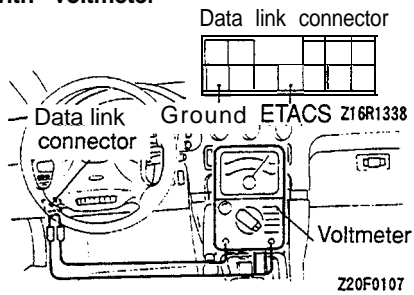
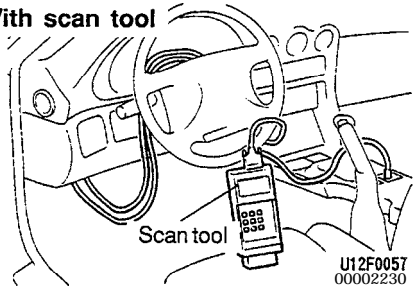
**With voltmeter****With scan tool****INPUT SIGNAL****<Up to 1993 models>****When using the scan tool (MUT) or voltmeter**

Using the scan tool or voltmeter, check whether or not the input signals from each switch are being input to the ETACS unit.

- (1) Connect the scan tool to the data link connector located at the right side of the junction block or connect the voltmeter between the ETACS terminal and the ground terminal.
- (2) Check if the buzzer of the scan tool sounds or the needle of the voltmeter moves when each switch is operated. If the buzzer sounds or the needle moves, the input signals are being input to the ETACS unit, so that switch can be considered to be functioning normally. If not, the switch or switch input circuit is faulty. Check the switch and the switch input circuit.

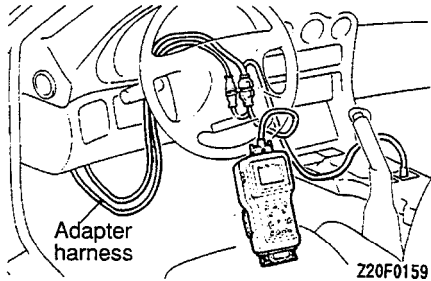
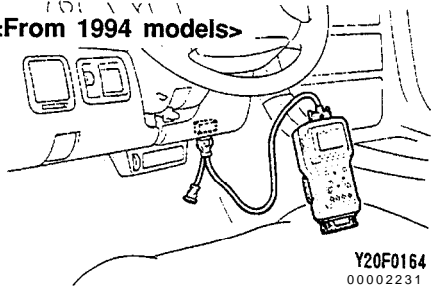
**When using the MUT-II  
<Up to 1993 models>****<From 1994 models>****<All models>****When using the scan tool (MUT-II)**

- (1) Connect the scan tool to the data link connector. When connecting the scan tool to a vehicle up to 1993 models, use the adapter harness supplied together.

**Caution**

**Turn off the ignition switch beforehand whenever the scan tool is connected or disconnected.**

- (2) If the scan tool makes a peep sound when each switch is operation (turned ON/OFF), the input signal to ECU is normally sent from the switch circuit system.

**<From 1994 models>****When using the voltmeter**

- (1) Connect a voltmeter to the ETACS terminal and the ground terminal of the data link connector using the special tool.
- (2) If the voltmeter pointer deflects once when each switch is operated (turned ON/OFF), the input signal to ECU is normally sent from the switch circuit system.

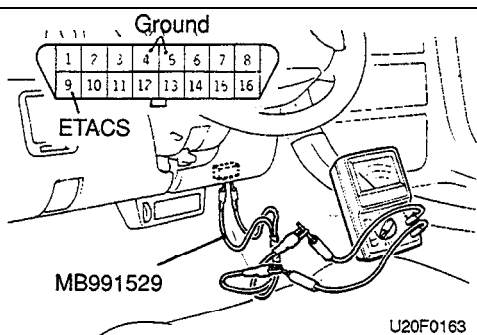

DOOR LIGHT AND LUGGAGE COMPARTMENT LIGHT  
CIRCUIT DIAGRAM <HATCHBACK>

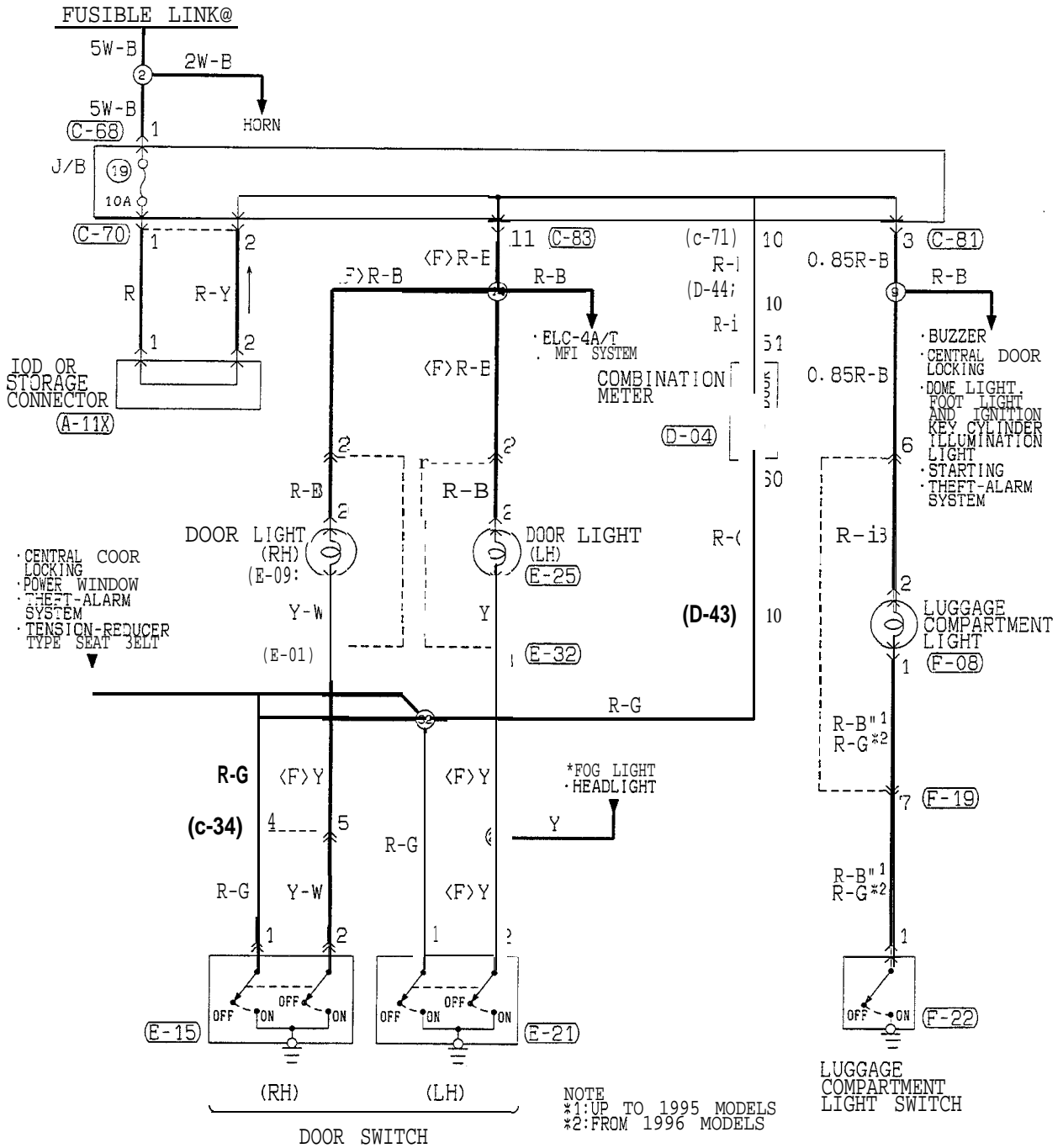

NOTE  
\*1: UP TO 1995 MODELS  
\*2: FROM 1996 MODELS

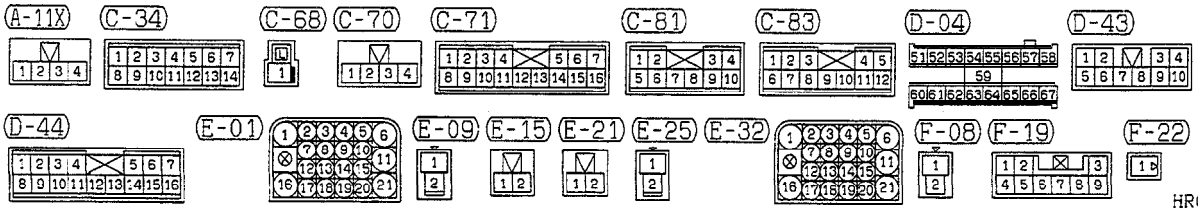

HR08M14AA

TSB Revision

CIRCUIT DIAGRAM <CONVERTIBLE>

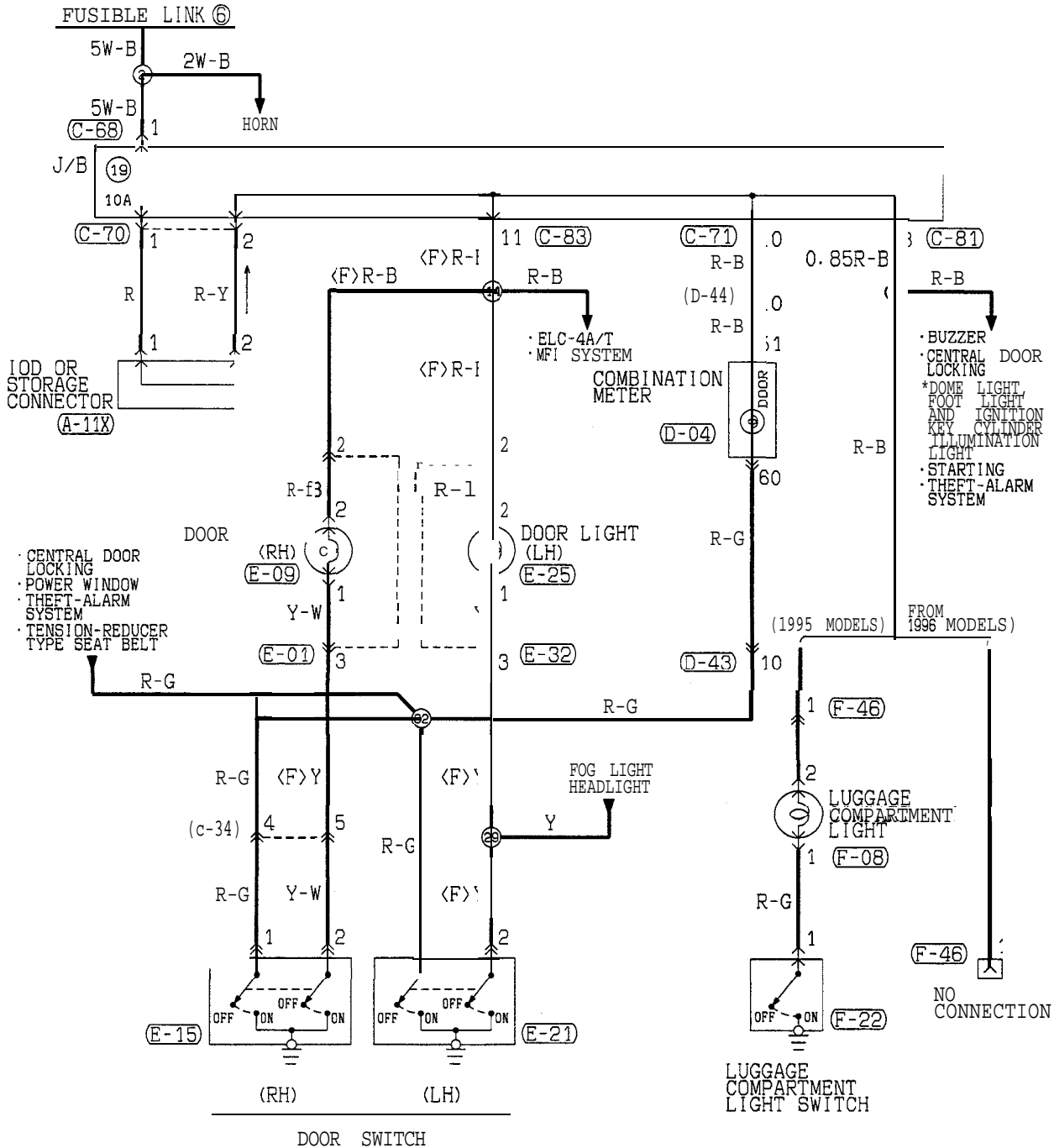

<b>A-11X</b> M 1 2 3 4	<b>C-34</b> 1 2 3 4 5 6 7 8 9 10 11 12 13 14	<b>C-68</b> 1	<b>C-70</b> M 1 2 3 4	<b>C-71</b> 1 2 3 4 5 6 7 8 9 10 11 12 13 14 15 16	<b>C-81</b> 1 2 3 4 5 6 7 8 9 10	<b>C-83</b> 1 2 3 4 5 6 7 8 9 10 11 12	<b>(D-04)</b> 5 1 5 2 5 3 5 4 5 5 5 6 5 7 5 8 5 9 6 0 6 1 6 2 6 3 6 4 6 5 6 6 6 7	<b>(D-43)</b> 1 2 M 3 4 5 6 7 8 9 10	
<b>D-44</b> 1 2 3 4 5 6 7 8 9 10 11 12 13 14 15 16	<b>E-01</b> 1 2 3 4 5 6 7 8 9 10 11 12 13 14 15 16 17 18 19 20 21	<b>E-09</b> 1	<b>E-15</b> M 1 2	<b>E-21</b> M 1 2	<b>E-25</b> 1	<b>E-32</b> 1 2 3 4 5 6 7 8 9 10 11 12 13 14 15 16 17 18 19 20 21	<b>F-08</b> 1	<b>F-22</b> 1 2	<b>F-46</b> 1 2 3 4 5 6 7 8 9 10 11 12 13 14 15 16 17

HR08M15AA

TSB Revision

**OPERATION**

- Battery voltage is always applied (via sub-fusible link No. (6) and multipurpose fuse No. (19)) to the luggage compartment light and door light.
- When the door is opened, the door switch is switched ON and the door light illuminates.
- When the liftgate is opened, the luggage compartment light switch is switched ON and the luggage compartment light illuminates.

**GLOVE BOX LIGHT, VANITY MIRROR LIGHT AND INSPECTION LIGHT****OPERATION**

- When the lighting switch is placed in the TAIL or HEAD position, and the contacts of the tail light relay close, battery voltage is applied via the dedicated fuse (2) to the glove box light, the vanity mirror light and the inspection light.
- When the glove box is opened, the glove box illumination light switch is switched ON and the glove box illumination light illuminates.
- When the vanity mirror lid is opened, the vanity mirror light switch is switched ON and the vanity mirror light illuminates.
- When the engine hood is opened, the inspection light switch is switched ON and the inspection light illuminates.

**NOTE**

The light automatic shut-off system is valid for the glove box light, vanity mirror light and inspection light. (Refer to P.54-37.)



CIRCUIT DIAGRAM

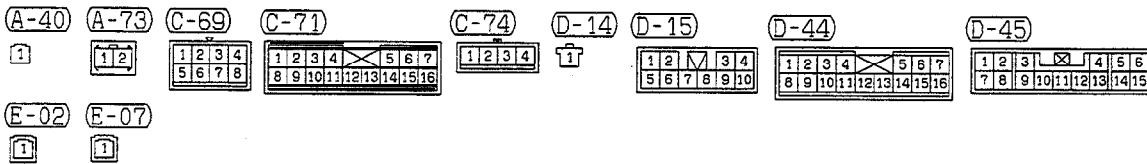
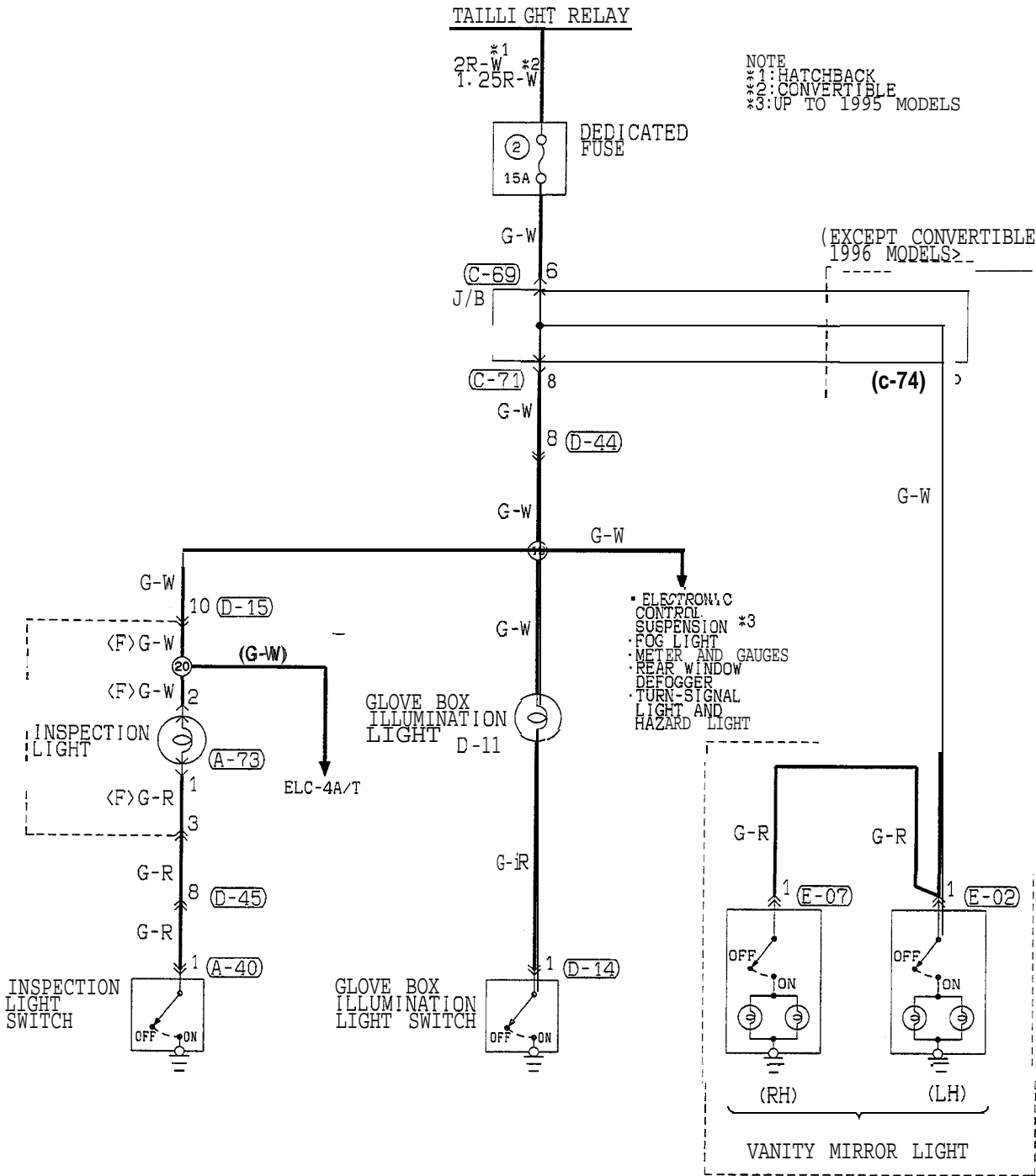

HR08M09AA

**BACK-UP LIGHT**  
CIRCUIT DIAGRAM <UP TO 1993 MODELS>

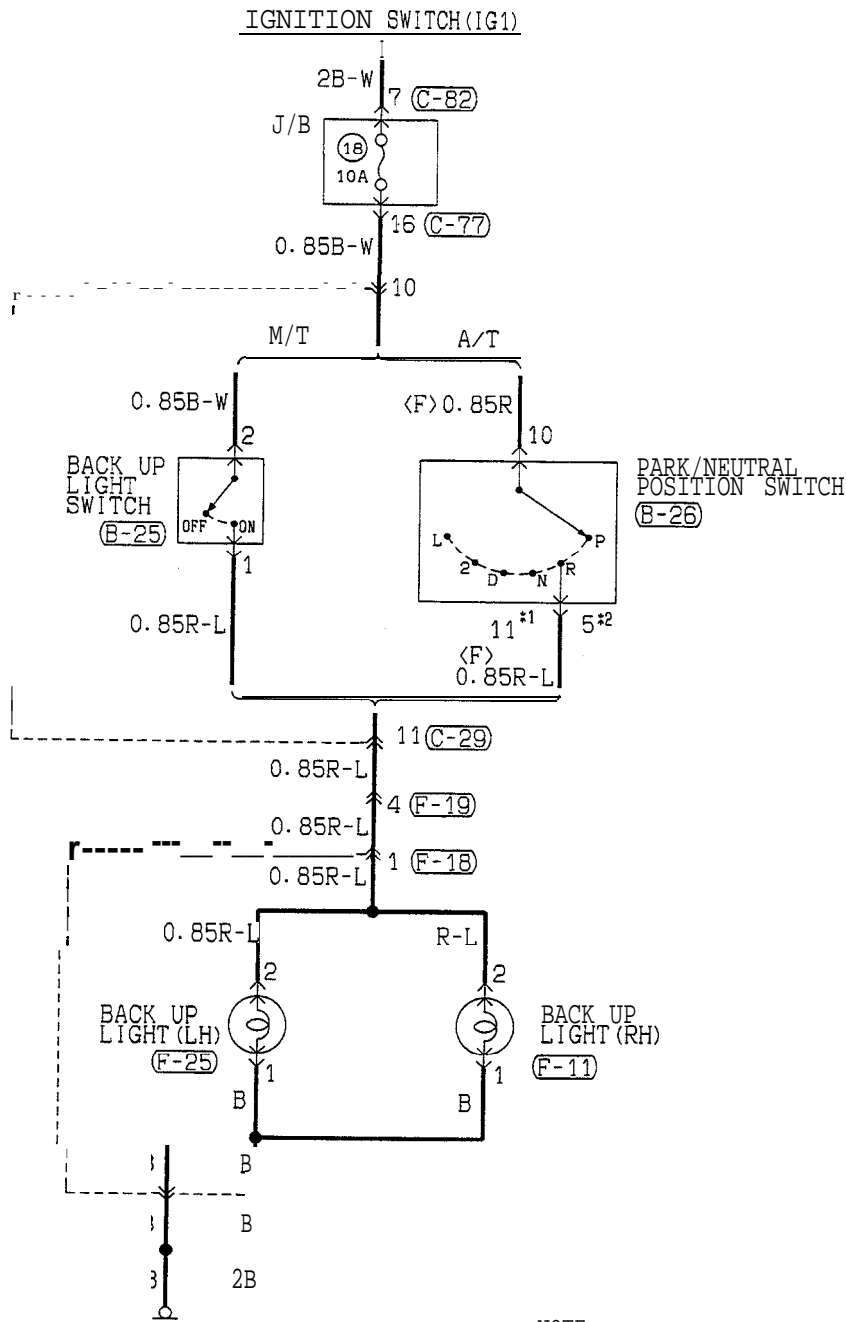

NOTE  
\*1: 1992 MODEL  
\*2: FROM 1993 MODEL

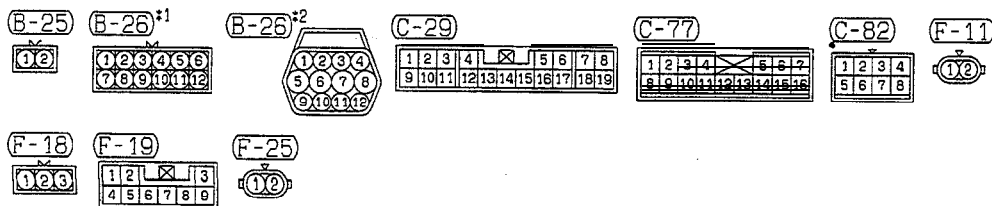

TSB Revision

CIRCUIT DIAGRAM <HATCHBACK> (FROM 1994 MODELS)

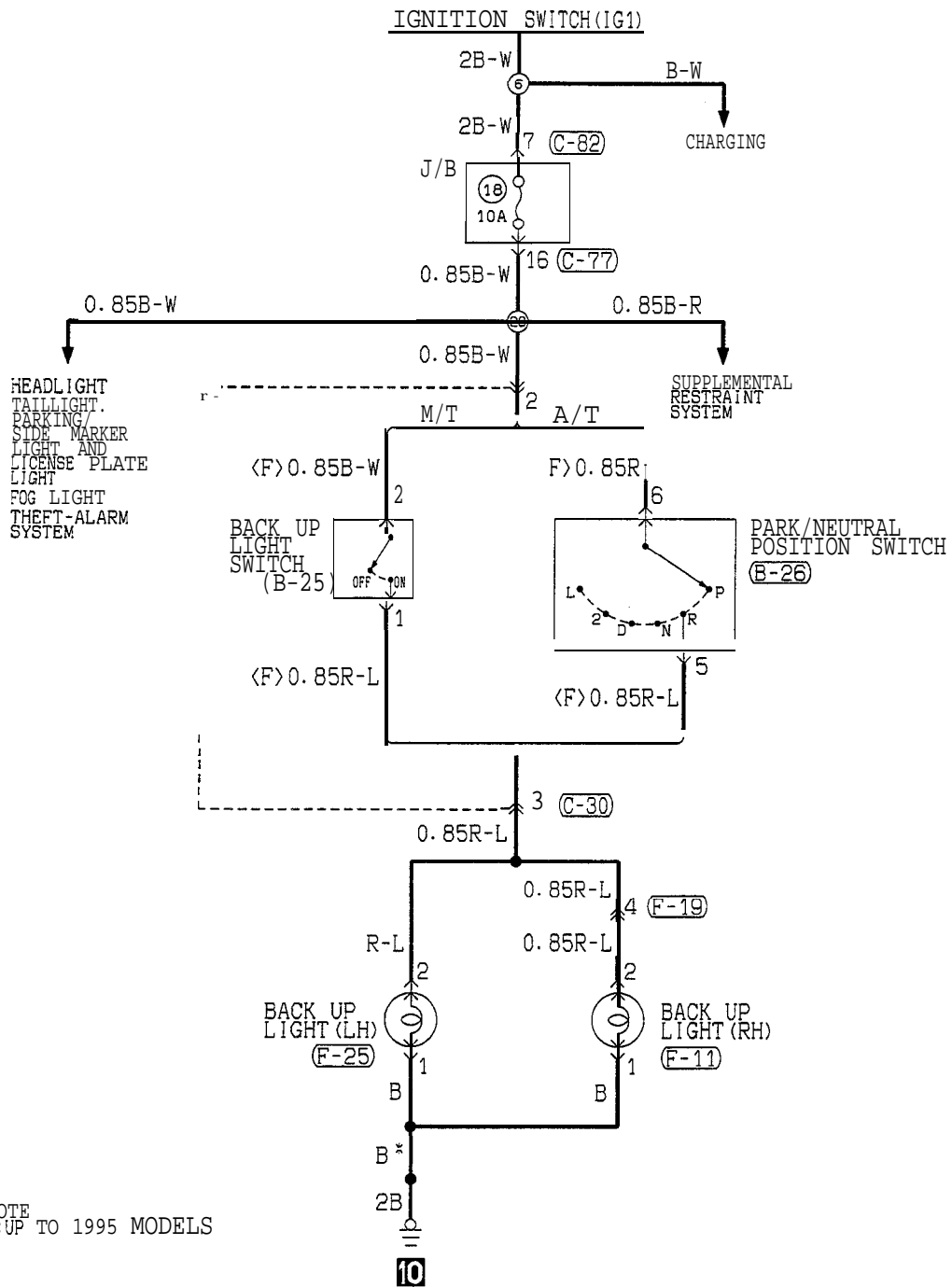

NOTE  
\*:UP TO 1995 MODELS

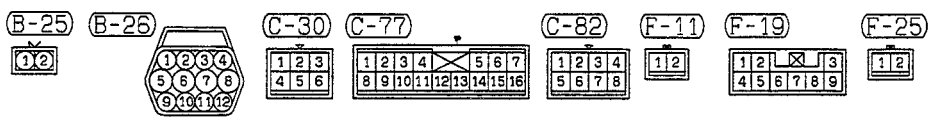

TSB Revision

## CIRCUIT DIAGRAM <CONVERTIBLE> (FROM 1995 MODELS)

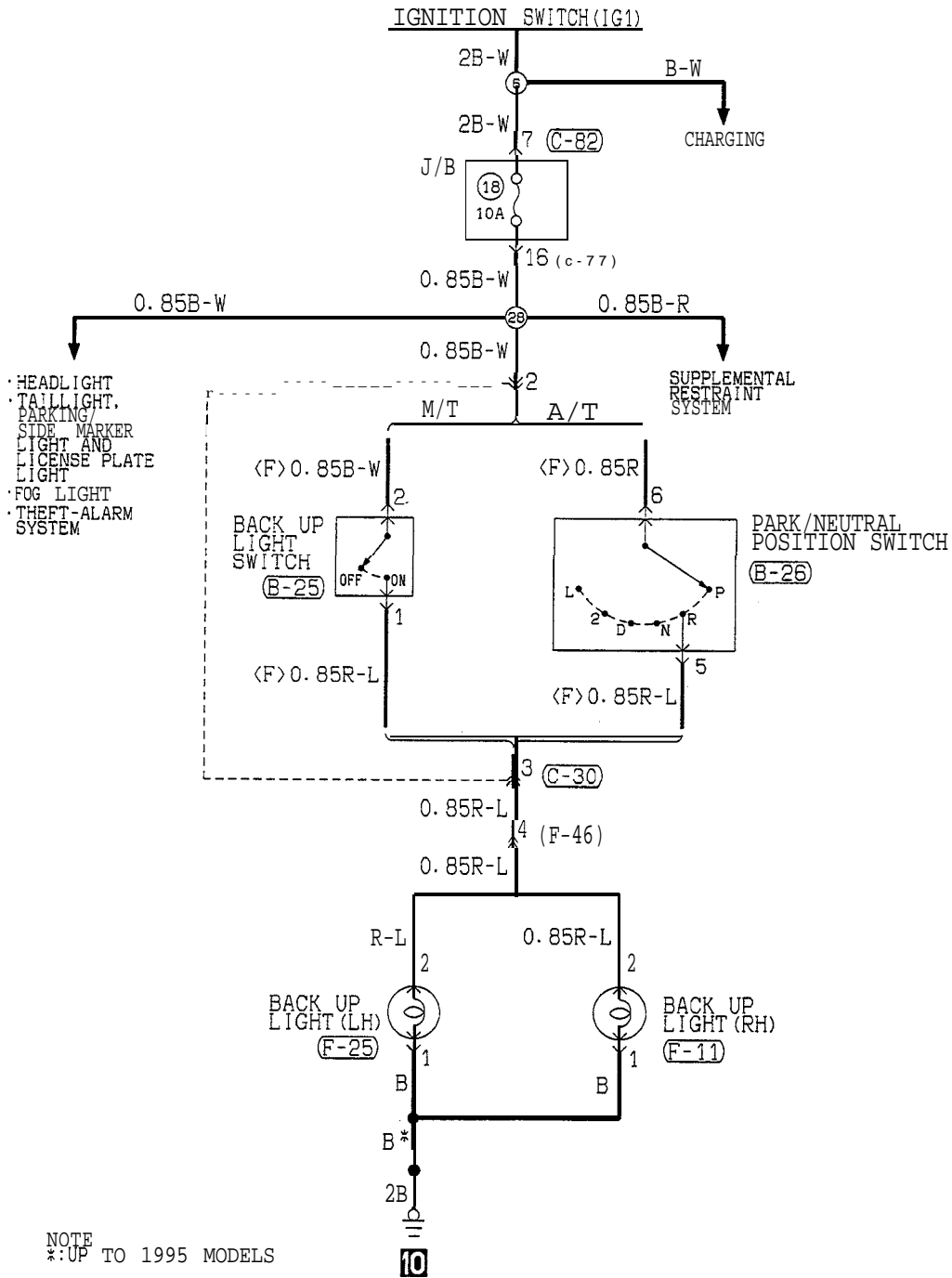

NOTE  
\*: UP TO 1995 MODELS

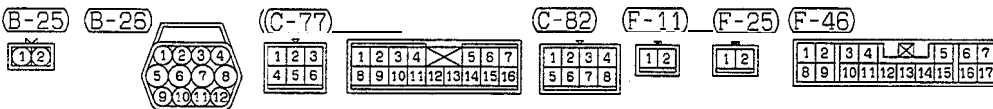

## COMPONENT LOCATION

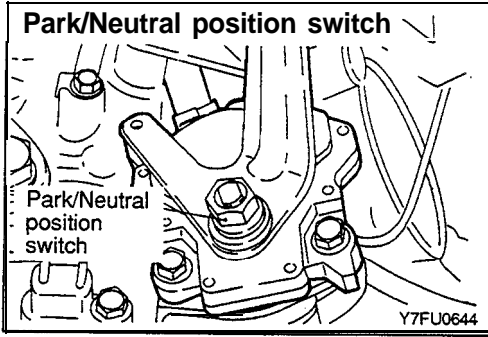

## OPERATION

- When, with the ignition switch at the "ON" position, the shift lever (or the selector lever) is moved to the "R" position, the backup light switch (M/T) is switched ON (or the park/neutral position switch (A/T) is switched to the "R" position), and the backup light illuminates.

## TURN-SIGNAL LIGHT AND HAZARD LIGHT

### OPERATION

1. When operation is normal
  - When the ignition switch is switched to the ON position, battery voltage is applied (via the multipurpose fuse (11) and hazard switch) to the turn-signal and hazard flasher unit.
  - When the turn-signal switch is switched to the LH position, Tr1 (within the flasher unit) is switched ON and OFF repeatedly. Then the contacts of the relay 1 (also within the flasher unit) repeatedly switch from ON to OFF, causing the turn-signal lights and turn-signal indicator light LH to flash.
  - When the turn-signal switch is switched to the RH position, Tr2 (within the flasher unit) is switched ON and OFF repeatedly. Then the contacts of relay 2 (also within the flasher unit) repeatedly switch from ON to OFF, causing the turn-signal lights and turn-signal indicator light RH to flash.
2. If one of the bulbs is burned out
  - If the LH (or RH) turn-signal light bulb is burned-out, the resistance of the turn-signal circuit as a whole increases, resulting in shorter ON and OFF intervals of the LH Tr1 (or RH Tr2) and a higher flashing rate of the LH lights (or RH lights).

### <Hazard-warning lights,

- When the hazard-warning switch is switched to the "ON" position, the relay contact of the turn signal and hazard flasher unit is switched ON and OFF repeatedly, in the same manner as for the operation of the turn-signal lights, and the left and right turn-signal lights and turn-signal indicator lights simultaneously flash repeatedly.

### NOTE

- (1) The number of flashes of the hazard-warning lights does not change if there is damaged or disconnected wiring of one light.
- (2) The light automatic shut-OFF system is valid for the illumination light of the hazard switch. (Refer to P.54-37.)

### TROUBLESHOOTING HINTS

1. The turn-signal lights and hazard-warning lights do not operate at all.
  - Check the hazard switch contact (power supply side).
  - Check the turn-signal and hazard flasher unit.
2. All turn-signal lights at the left (or right) side do not function.
  - (1) The hazard-warning lights function normally-
    - Check the hazard switch contact (turn-signal side).
    - Check the turn-signal switch.
3. The number of flashes of the turn-signal lights is excessive.
  - Check the bulbs.
4. The hazard-warning lights do not function.
  - (1) The turn-signal lights function normally.
    - Check the hazard switch contact (hazard-warning light side).

### NOTE

For the troubleshooting hints of the automatic light shut-OFF system, refer to P.54-37.

### COMPONENT LOCATION

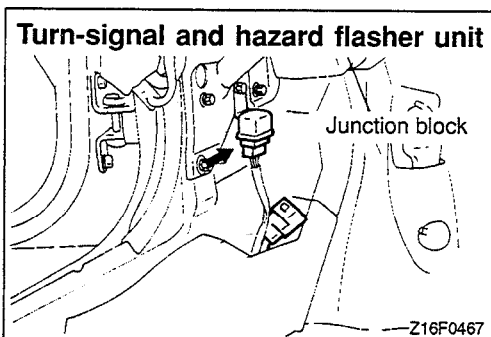

CIRCUIT DIAGRAM <TYPE 1> (UP TO 1994 MODELS)

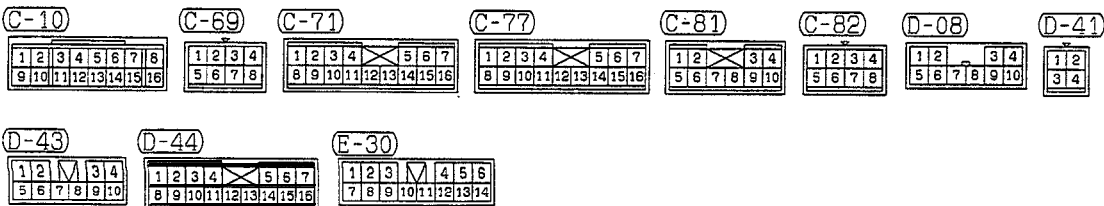
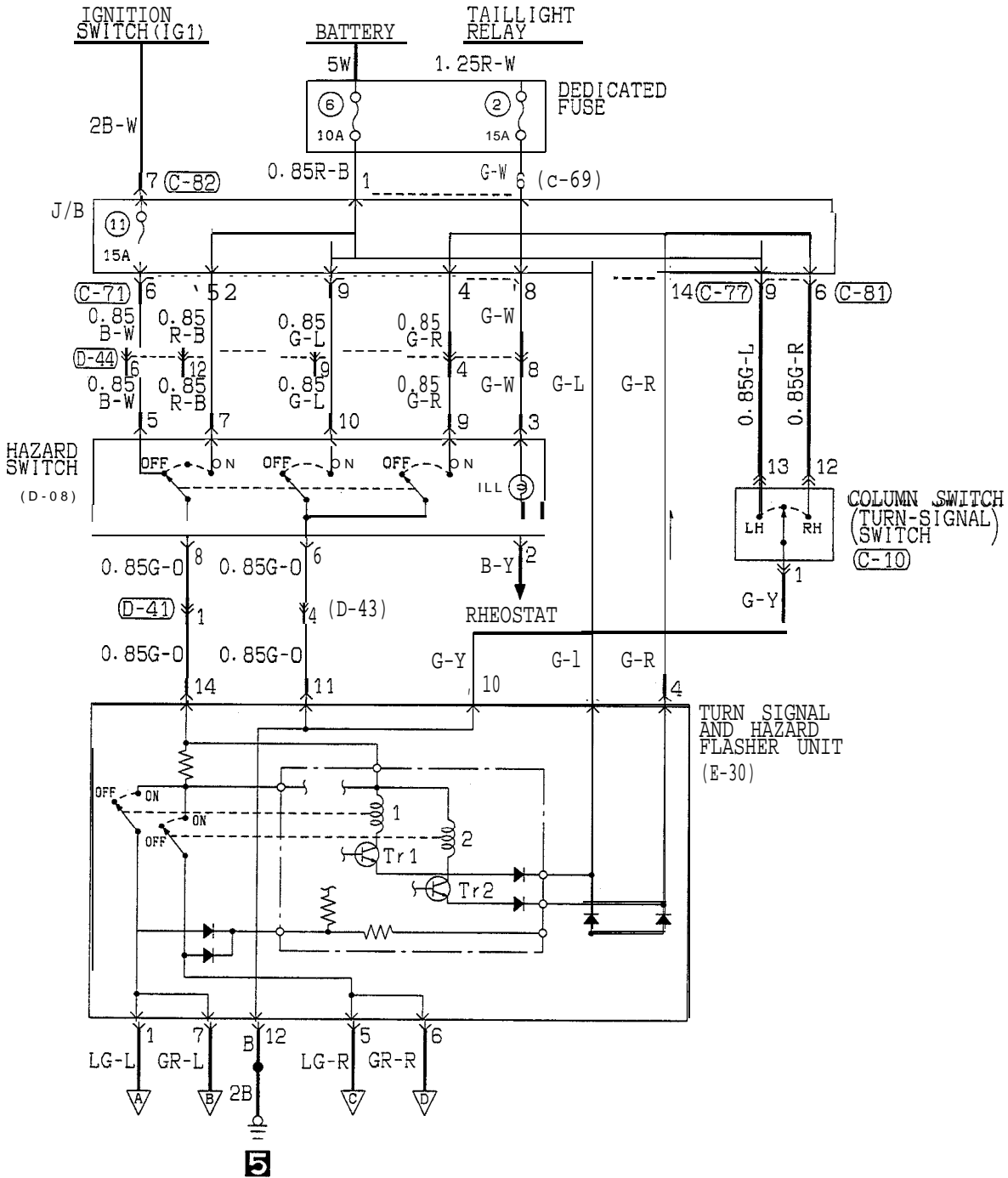

TSB Revision

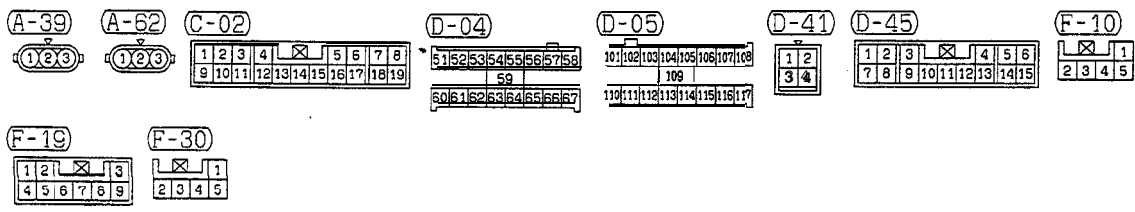
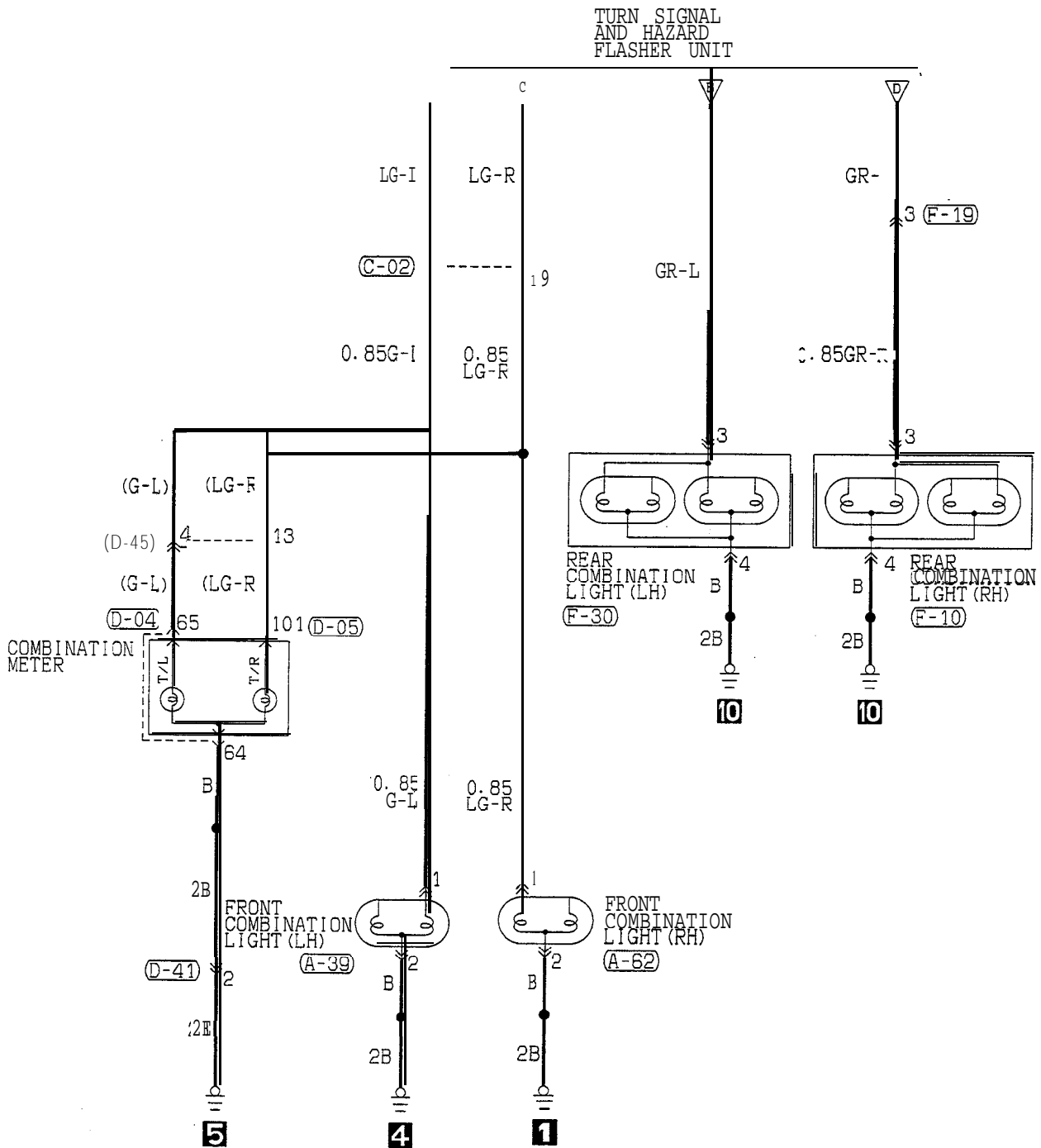

HR09M00A5

TSB Revision



CIRCUIT DIAGRAM <TYPE 2> (UP TO 1993 MODELS)

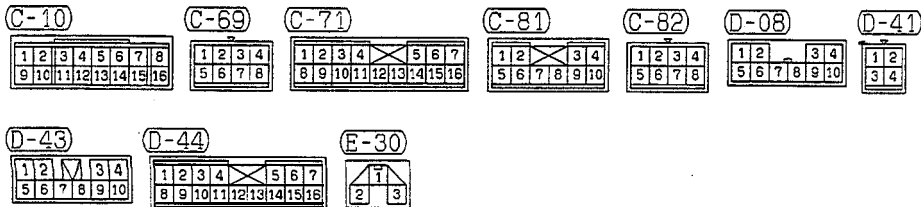
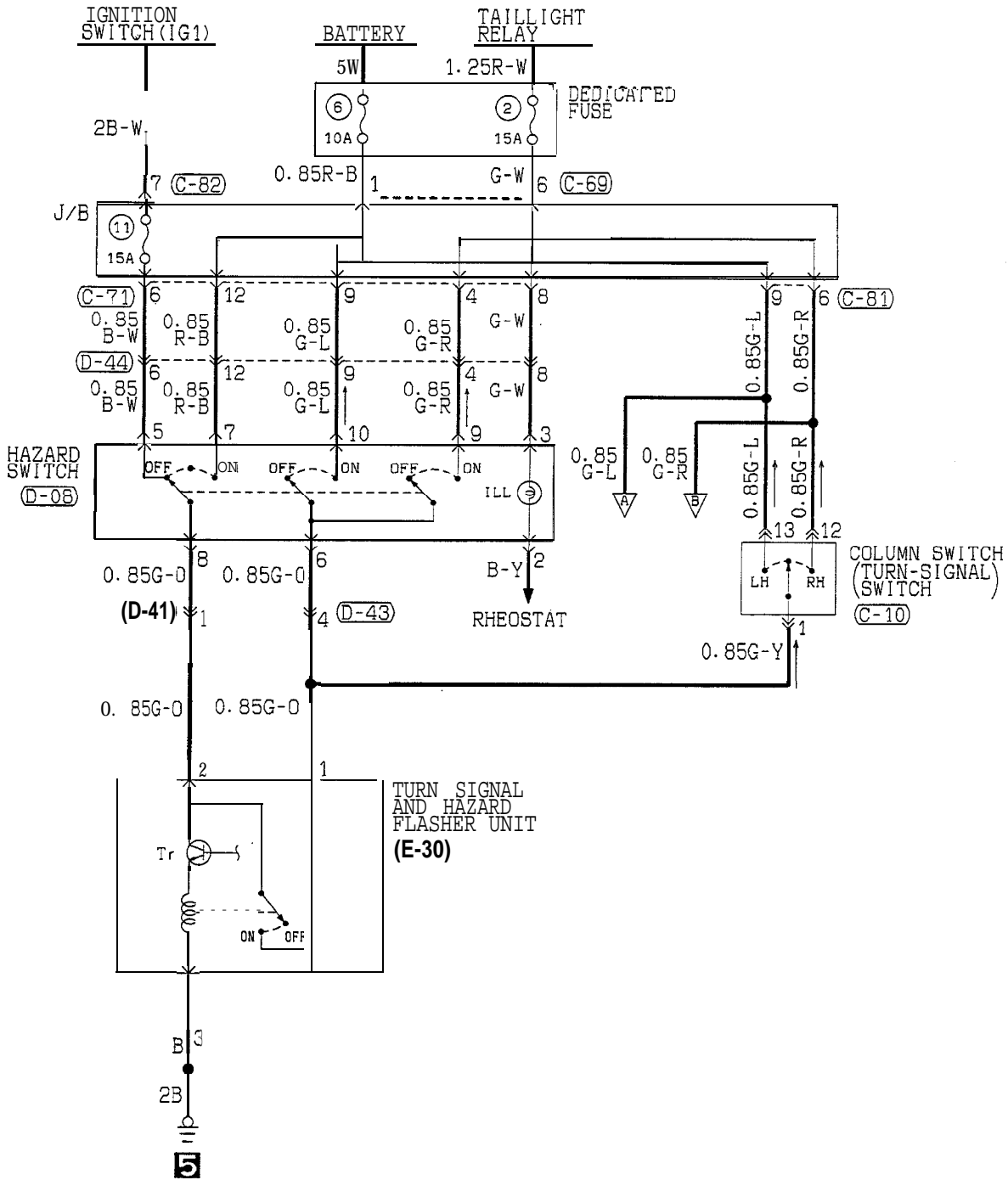

TSB Revision

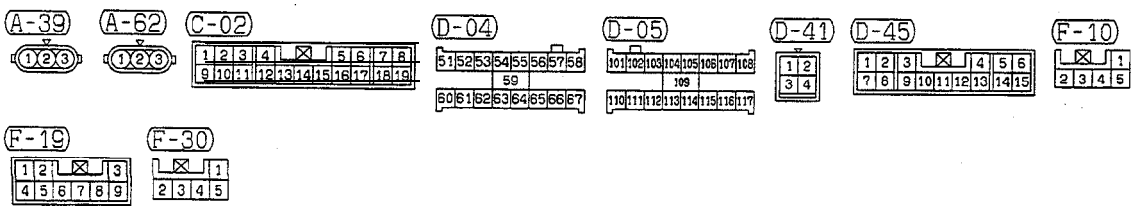
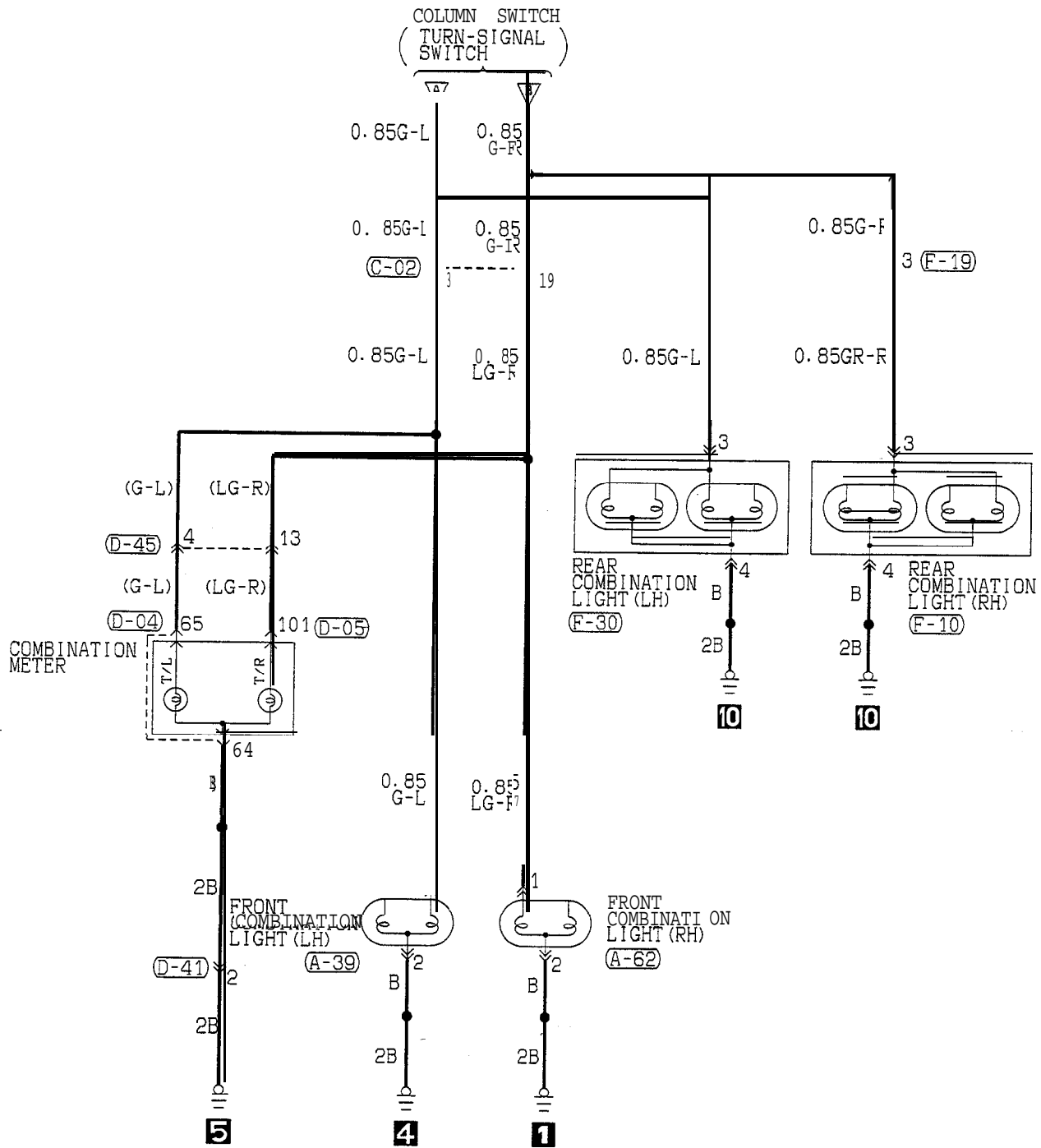

CIRCUIT DIAGRAM <HATCHBACK> (FROM 1995 MODELS)

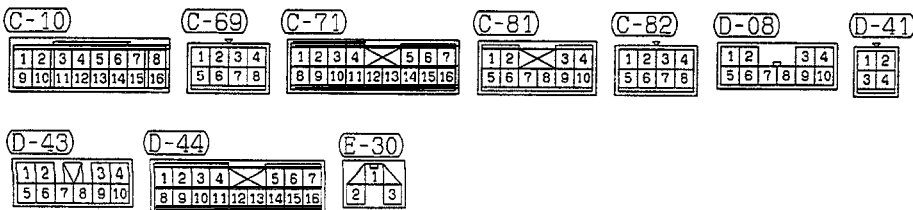
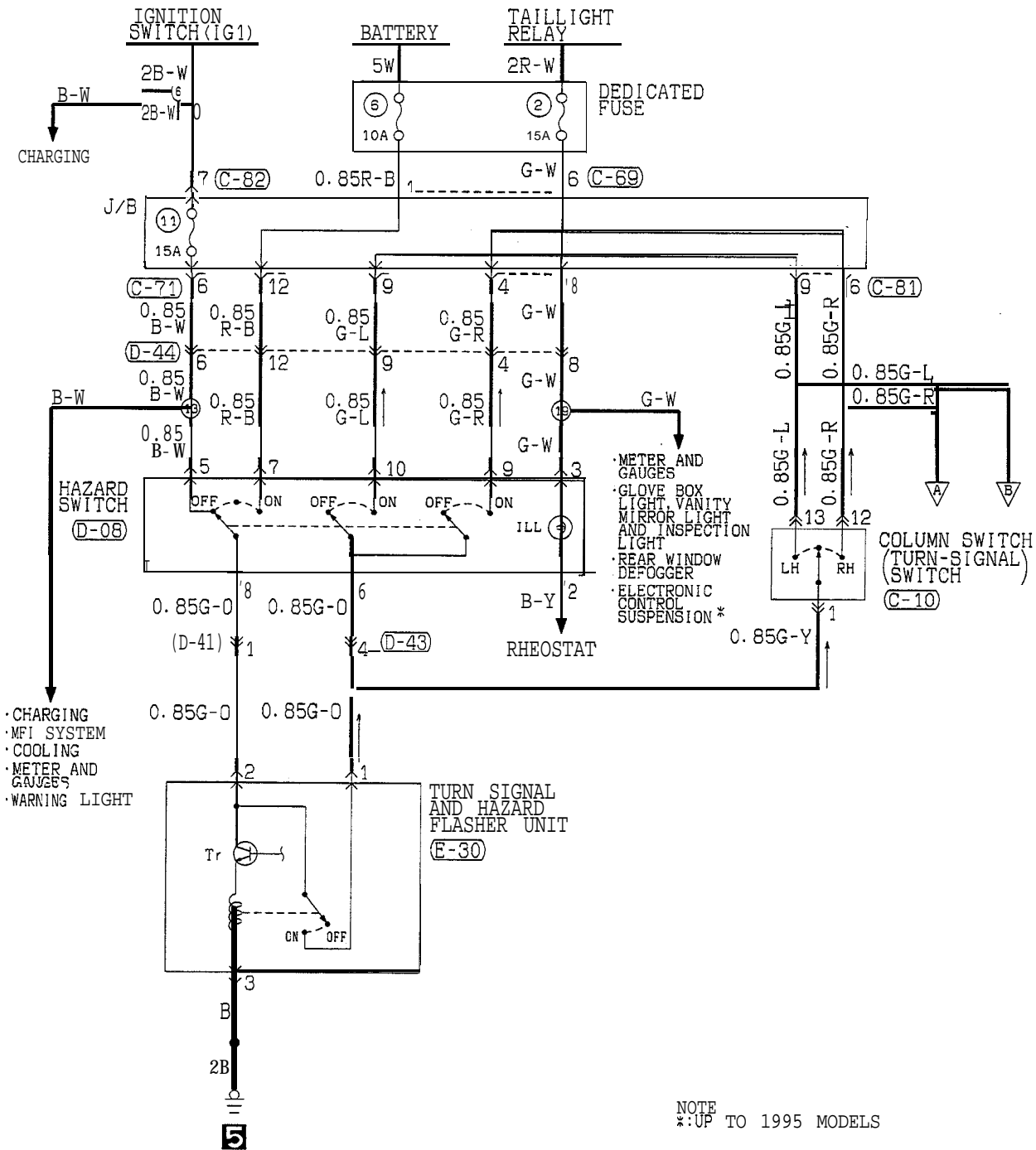

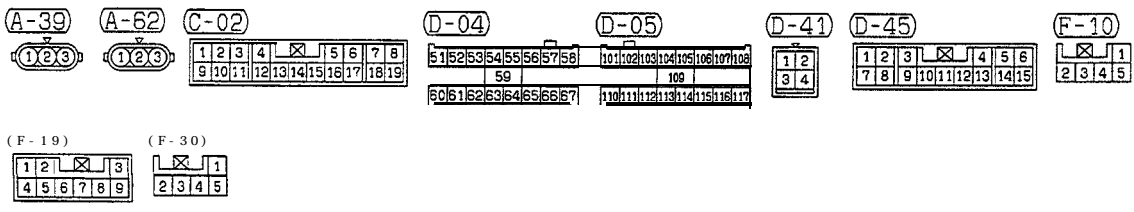
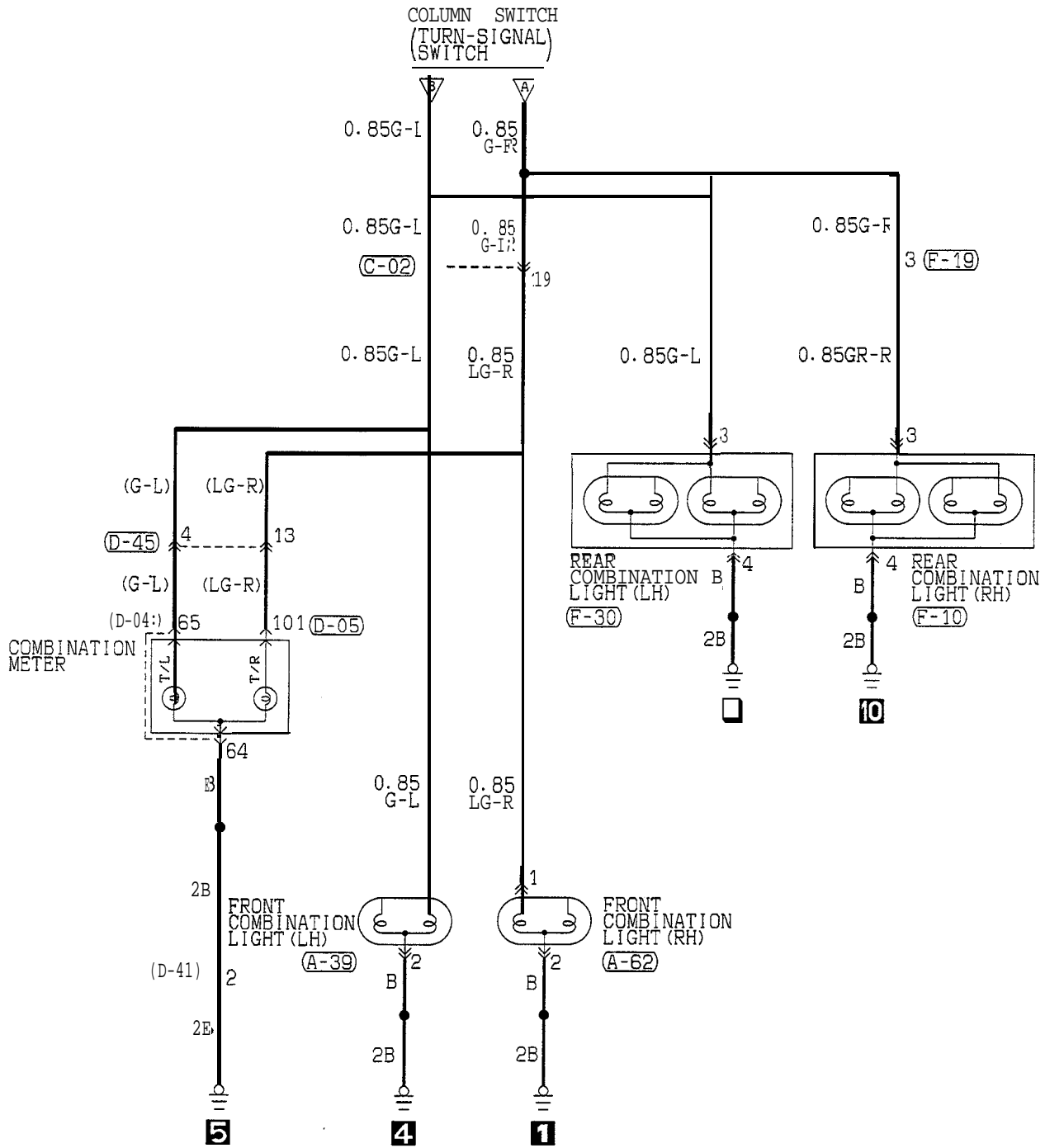

HR09M02AB

TSB Revision



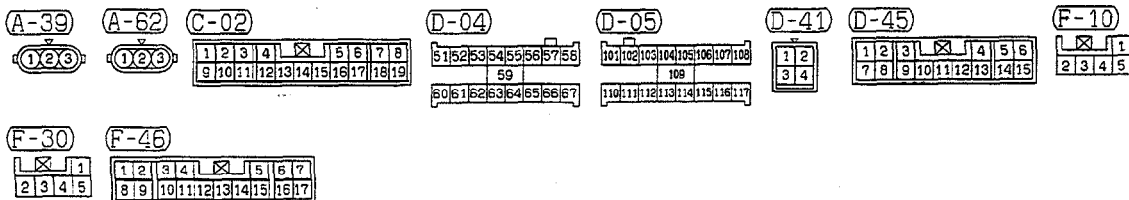
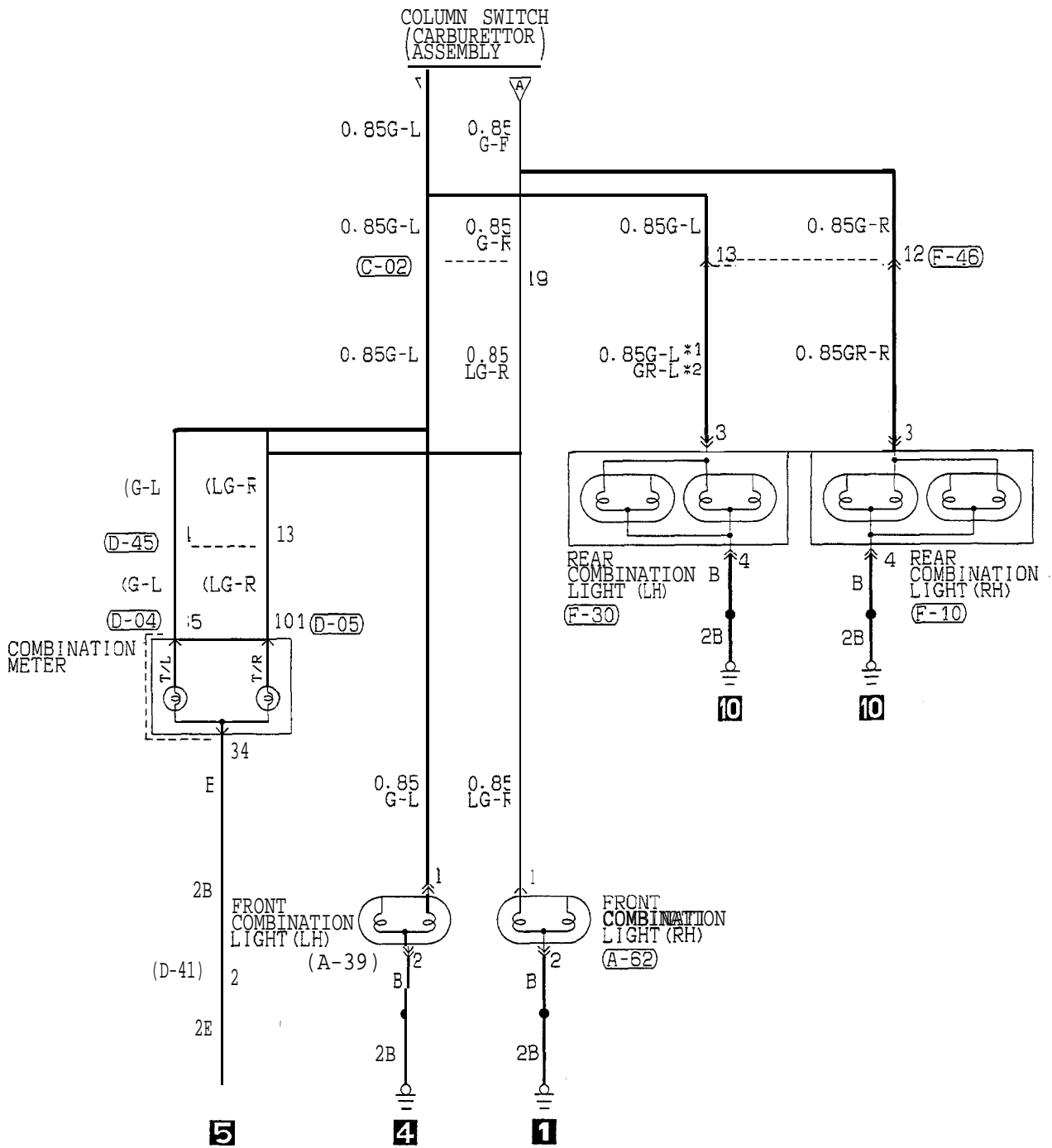

HR09M03AB

TSB Revision

STOP LIGHT  
CIRCUIT DIAGRAM <HATCHBACK>

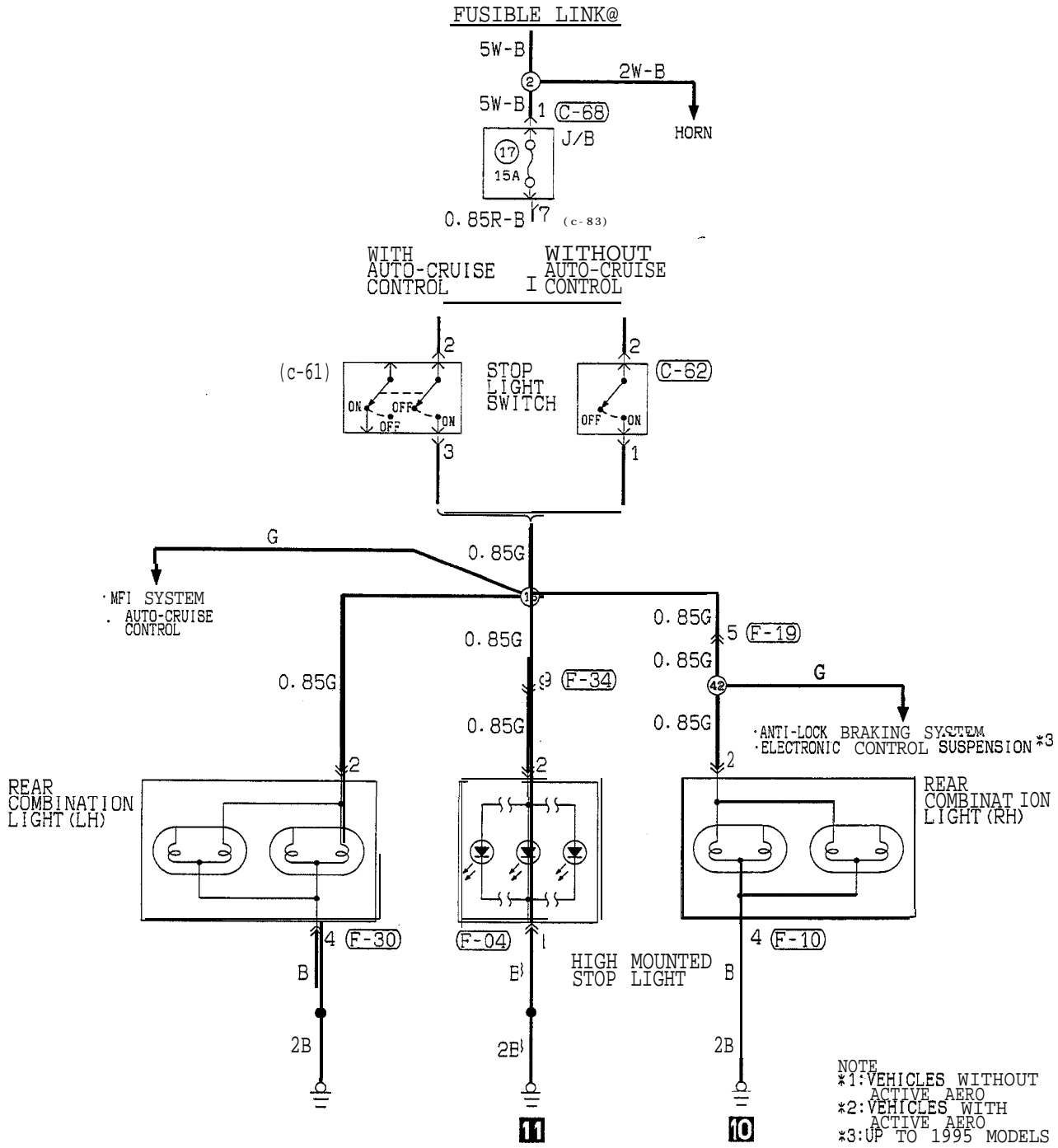

NOTE  
\*1: VEHICLES WITHOUT ACTIVE AERO  
\*2: VEHICLES WITH ACTIVE AERO  
\*3: UP TO 1995 MODELS

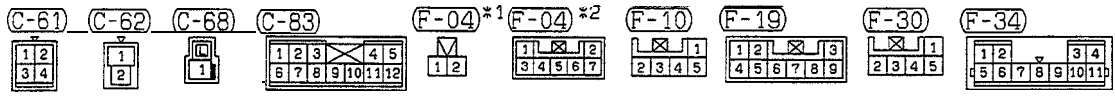

TSB Revision

CIRCUIT DIAGRAM <CONVERTIBLE>

EUSIBLE N K @

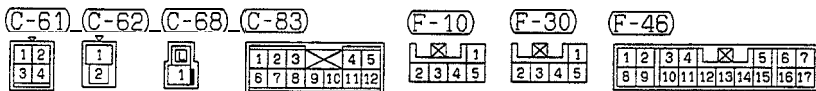
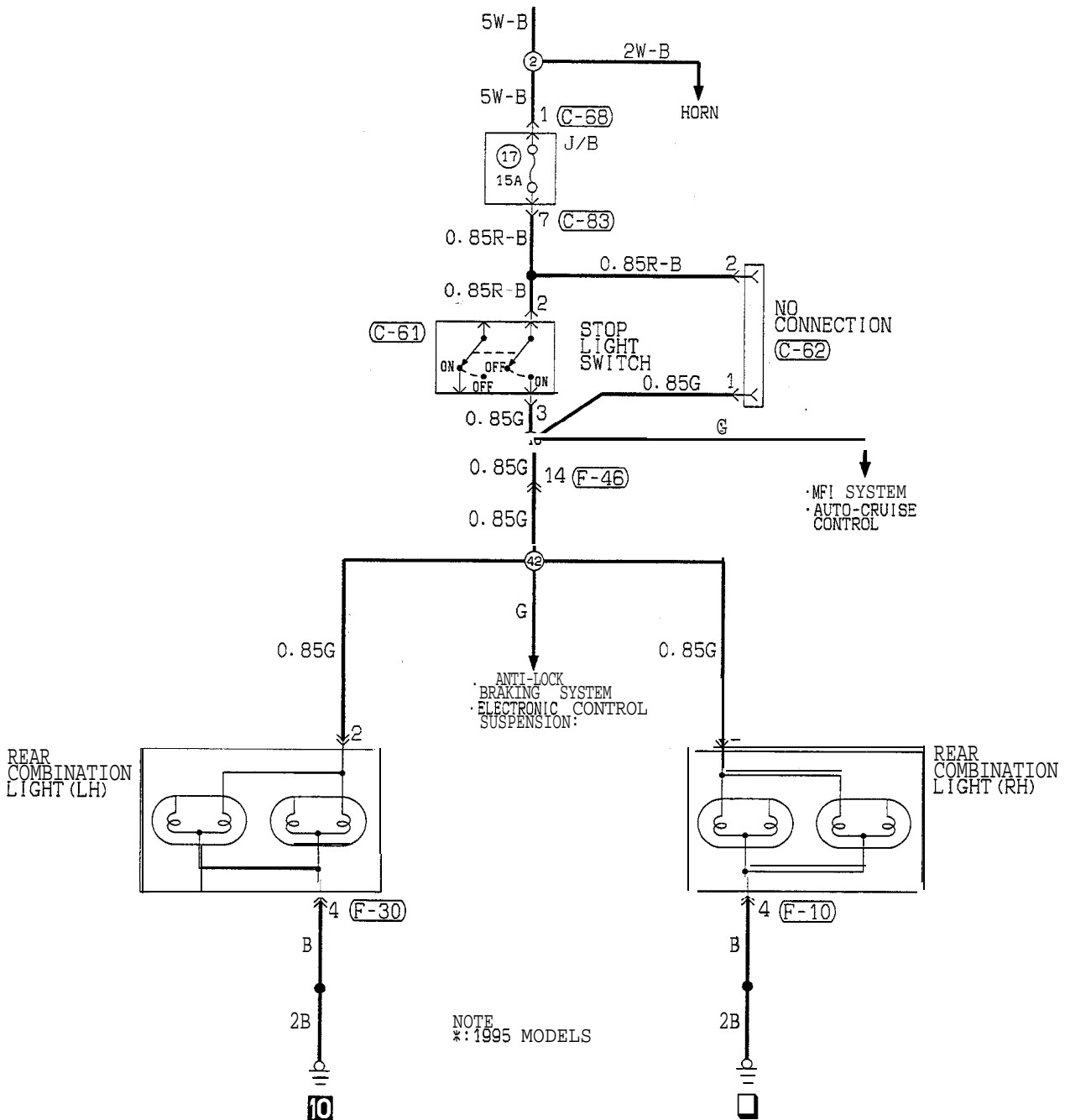



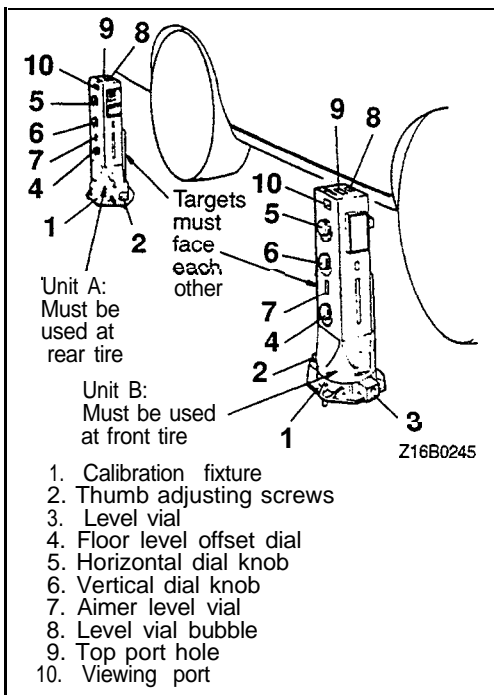

## ON-VEHICLE SERVICE

### HEADLIGHT AIMING

#### PRE-AIMING INSTRUCTIONS

##### (Up to 1993 models)

1. Test dimmer switch operation.
2. Observe operation of high beam light mounted in instrument cluster.
3. Inspect for badly rusted or faulty headlight assemblies. These conditions must be corrected before a satisfactory adjustment can be made.
4. Place vehicle on a level floor.
5. Bounce front suspension through three (3) oscillations by applying body weight to hood or bumper.
6. Inspect tire inflation.
7. Rock vehicle sideways to allow vehicle to assume its normal position.
8. If fuel tank is not full, place a weight in trunk of vehicle to simulate weight of a full tank [3 kg (6.5 lbs.) per gallon].
9. There should be no other load in the vehicle other than driver or substituted weight of approximately 70 kg (150 lbs.) placed in driver's position.
10. Thoroughly clean headlight lenses.
11. Adjust headlights following the instructions of the headlight tester manufacturer.

##### (From 1994 models)

1. Inspect for badly rusted or faulty headlight assemblies. These conditions must be corrected before a satisfactory adjustment can be made.
2. Place vehicle on a level floor.
3. Bounce front suspension through three (3) oscillations by applying body weight to hood or bumper.
4. Inspect tire inflation.
5. Rock vehicle sideways to allow vehicle to assume its normal position.
6. If fuel tank is not full, place a weight in trunk of vehicle to simulate weight of a full tank [3 kg (6.5 lbs.) per gallon].
7. There should be no other load in the vehicle other than driver or substituted weight of approximately 70 kg (150 lbs.) placed in driver's position.
8. Thoroughly clean headlight lenses.
9. When performing the visual headlight adjustment on vehicles with resin lens headlights, be sure to observe the following precautions.

#### Caution

**When adjusting one headlight, the other headlight should be turned off if possible. If this is not possible, do not cover the other headlight for more than three minutes while it is turned on. Otherwise, heat from the bulb may warp the headlight lens.**

#### NOTE

If the visual headlight adjustment at low beam is made, the adjustment at high beam is not necessary.

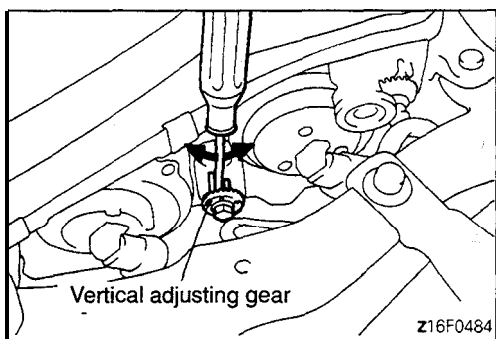

**VERTICAL ADJUSTING**

Adjust the vertical angle with the vertical adjusting gear so that the bubble of the vertical angle gauge is aligned with the "0" mark position.

**NOTE**

The beam angle will change about 0°12' with on mark.

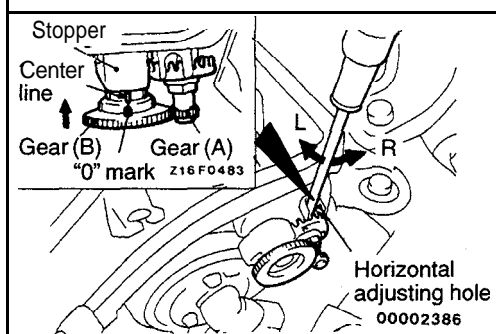
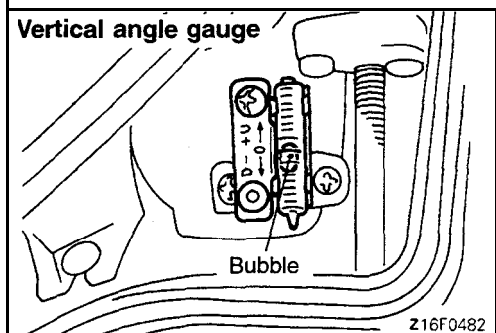

**HORIZONTAL ADJUSTING**

Insert a screwdriver in the horizontal adjusting hole and turn until the "0" mark and the center line are in alignment.

**NOTE**

The beam angle will change about 0°23' with on mark.

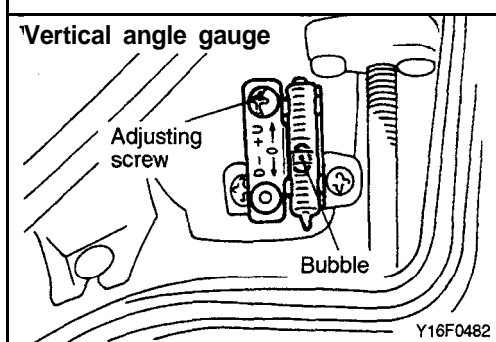

3. Check to see that the bubble in the headlight vertical angle gauge is in the illustrated position.
4. If the bubble is out of position, adjust by turning the adjusting screw.
5. Confirm that the "0" mark on the headlight horizontal angle adjusting gear (B) is in alignment with the center line.
6. If not, perform the adjustment as follows.
  - (1) Pull up the stopper.
  - (2) Push the gear (B) in the arrow direction to disengage it from the gear (A).
  - (3) Align the "0" mark on the gear (B) with the center line.
  - (4) Push down the stopper to engage the gear (B) with the gear (A).

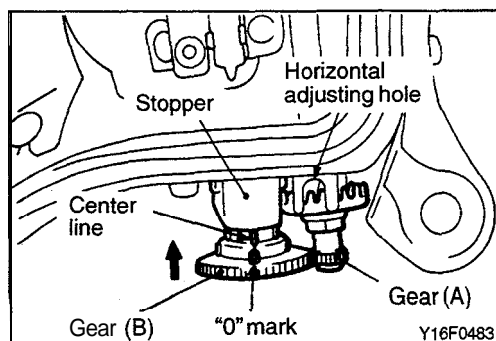

**LUMINOUS INTENSITY MEASUREMENT**

Measure the luminous intensity of headlights with a photo-meter in accordance with the instruction manual prepared by the manufacturer of the photometer and make sure that the luminous intensity is within the following limit.

**Limit: 20,000 cd or more**

**NOTE**

- (1) When measuring the luminous intensity of headlight, keep the engine at 2,000 rpm and have the battery charged.
- (2) If there are specific regulations for luminous intensity of headlights in the region where the vehicle is operated, make sure that the intensity conforms to the requirements of such regulations.

**FOG LIGHT AIMING**

1. Place vehicle on a known level floor 7.6 m (25 feet) from aiming screen or light colored wall.
2. Use adjusting screw to adjust the top end of high intensity zone to dimension A.

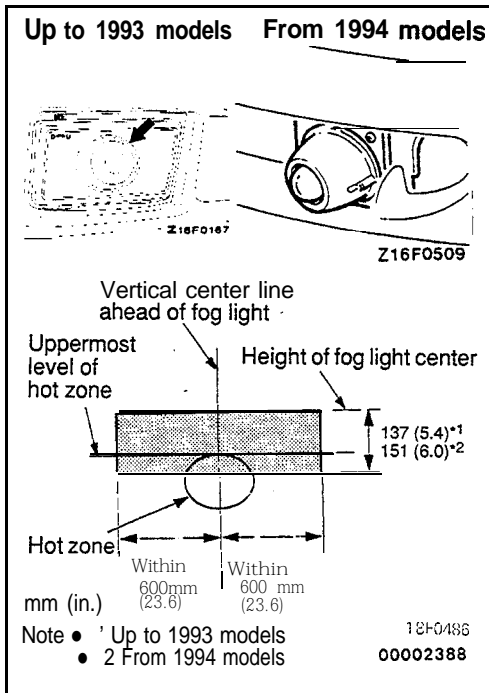
**BULB REPLACEMENT**

1. Disconnect the connector.
2. Turn the bulb socket counterclockwise to pull it out.

**Caution**

**Do not touch the surface of the headlight bulb with hands or dirty gloves. If the surface does become dirty, clean it with alcohol or thinner, and let it dry thoroughly before installing.**

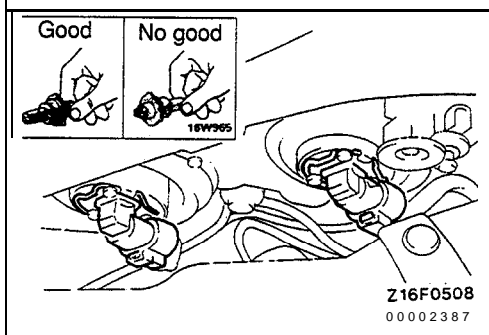

# HEADLIGHT

## REMOVAL AND INSTALLATION

(From 1994 models)

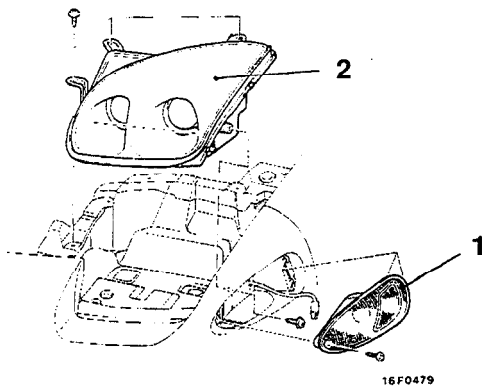

(Up to 1993 models)

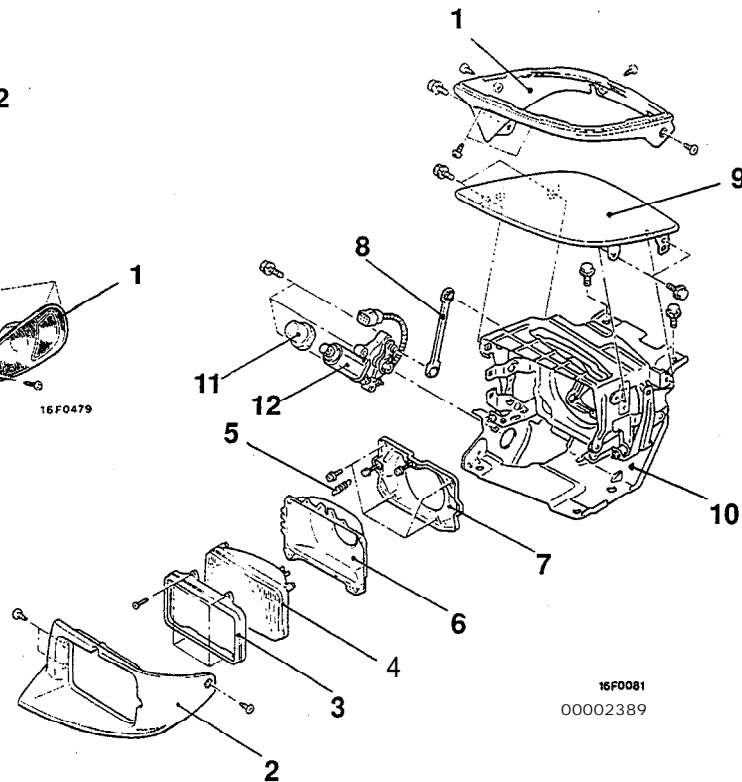

### Removal steps (From 1994 models)

1. Front combination light
2. Headlight



### Removal steps (Up to 1993 models)

1. Headlight bezel, upper
2. Headlight bezel, lower
3. Retaining ring
4. Headlight
5. Spring
6. Mounting ring
7. Housing
8. Rod assembly
9. Headlight hood
10. Link assembly
11. Boot
12. Pop-up motor



## REMOVAL SERVICE POINTS

### ◀A▶ HEADLIGHT BEZEL, UPPER REMOVAL

- (1) Raise the headlights by using the pop-up switch. Disconnect the negative (-) battery terminal.
- (2) Remove the headlight bezel, upper.

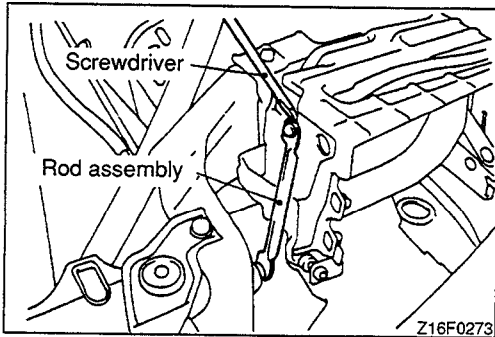

**◀B▶ ROD ASSEMBLY REMOVAL**

Using a flat head screwdriver (wrap cloth or similar on the ball joint area to prevent injury), disconnect the connector.

**NOTE**

When disconnecting the rod assembly from the link, hold the link by hand.

**INSPECTION**

**POP-UP MOTOR (Up to 1993 models) CHECK**

Rotate the manual knob of the pop-up motor clockwise by hand to check continuity between terminals.

Terminal	Continuity range
When the (+) terminal of the ohmmeter is connected to (1) and the (-) terminal is connected to (2)	B
When the (+) terminal of the ohmmeter is connected to (1) and the (-) terminal is connected to (5)	A

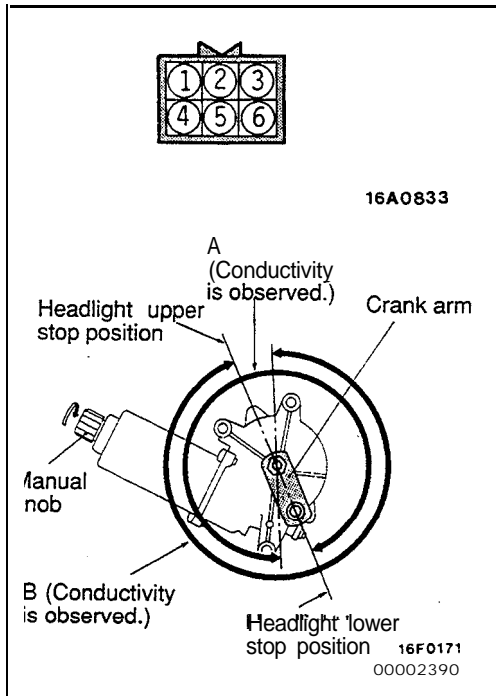

**FOG LIGHT**

**REMOVAL AND INSTALLATION**

(Up to 1993 models)

(From 1994 models)

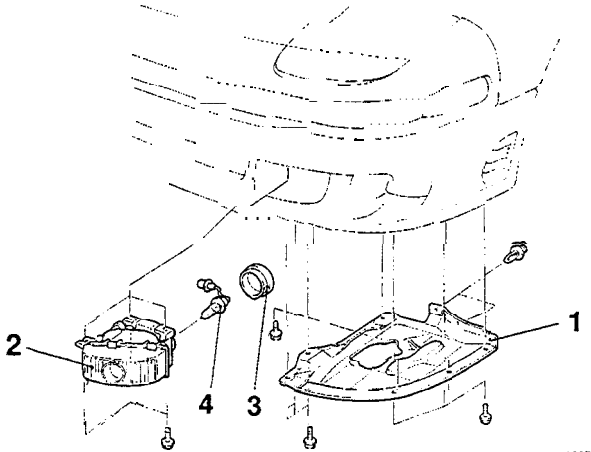

Z16F0227

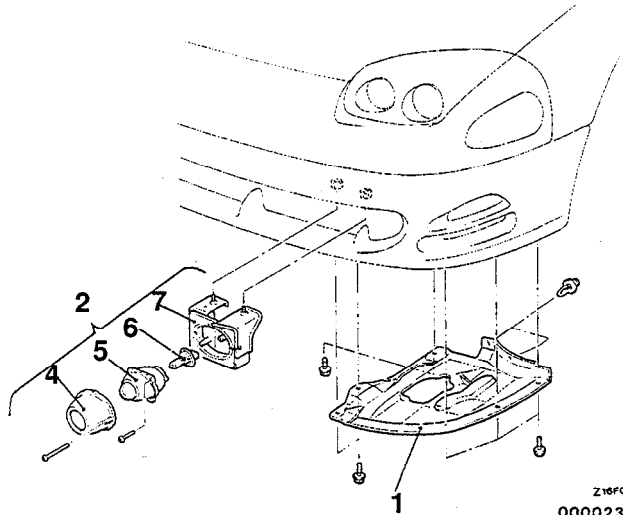

Z16F0485  
00002391

**Removal steps  
(Up to 1993 models)**

1. Front air side spoiler
2. Fog light assembly
3. Socket cover
4. Bulb



**(From 1994 models)**

1. Front air side spoiler
2. Fog light assembly

**Bulb replacement removal steps**

4. Lens
5. Projector unit
6. Bulb
7. Bracket



Up to 1993 models

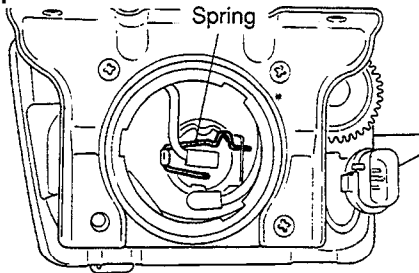

Z16F0288

From 1994 models

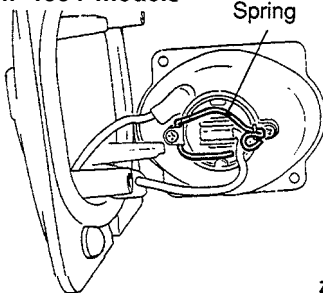

Z16F0485

**REMOVAL SERVICE POINT**

**◀A▶ BULB REMOVAL**

- (1) Remove the socket cover (Up to 1993 models).
- (2) Remove the bulb mounting spring and remove the bulb.

**Caution**

**Do not touch the surface of the headlight bulb with bare hands or dirty gloves.**

**If there are deposits on the surface, loosen and remove the deposits with a cloth dipped in alcohol or thinner, and let the surface dry before mounting the bulb.**

**FRONT COMBINATION LIGHT AND OPTICAL HORN LENS****REMOVAL AND INSTALLATION**

(Up to 1993 models)

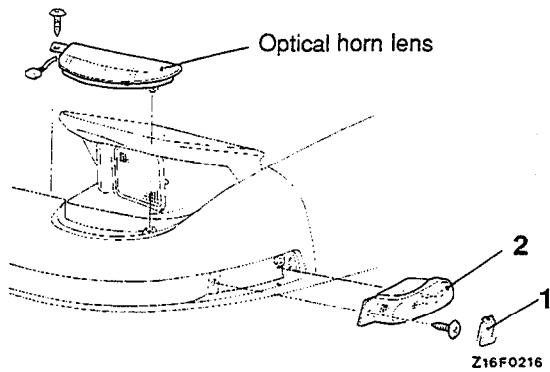

(From 1994 models)

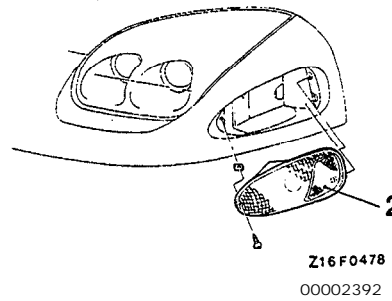
**Removal steps**

1. Light cover
2. Front combination light

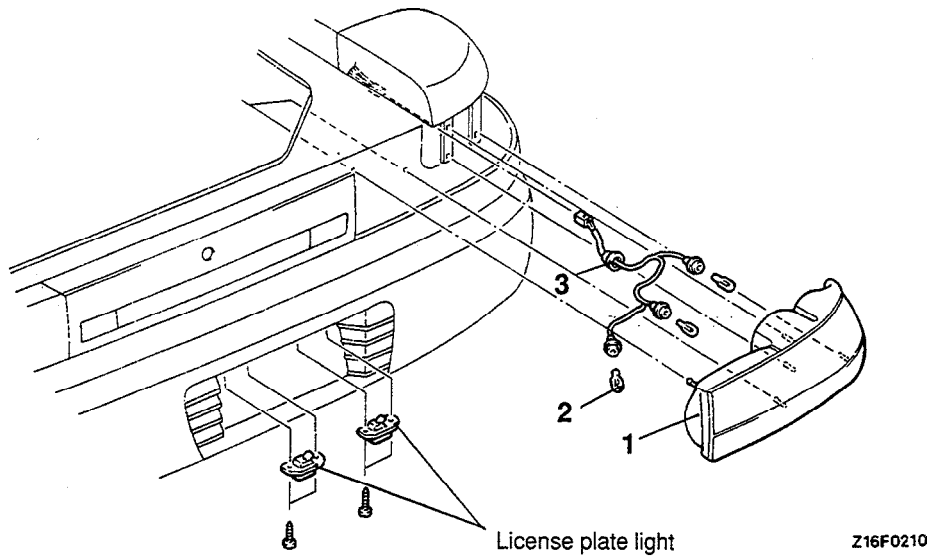
**REAR COMBINATION LIGHT AND LICENSE PLATE LIGHT****REMOVAL AND INSTALLATION****Removal steps**

1. Rear combination light unit
2. Bulb  
Rear side trim (Refer to GROUP 52A  
– Trims.)
3. Socket assembly

# HIGH MOUNTED STOP LIGHT

## REMOVAL AND INSTALLATION

<Vehicles with rear spoiler>

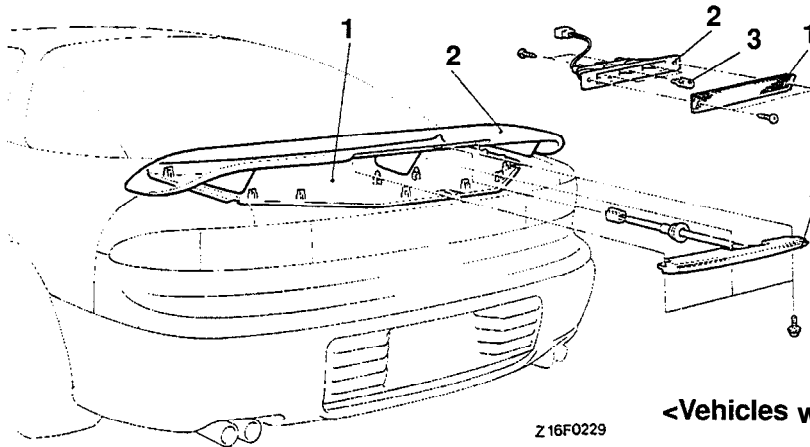

<Vehicles with active rear spoiler>

<Vehicles with fixed rear spoiler>

<Vehicles without rear spoiler>

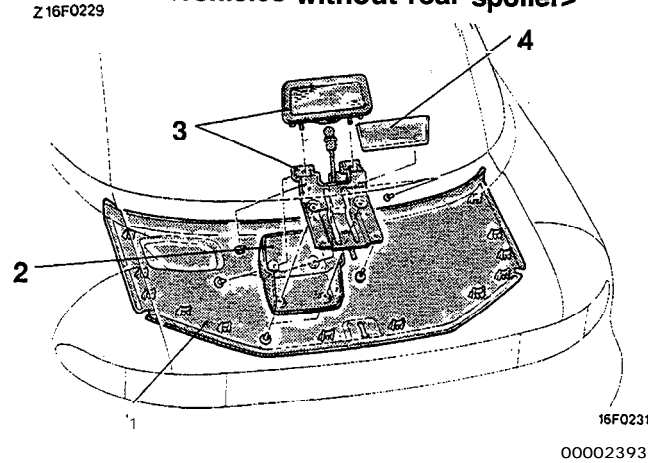

### Removal steps

- <Vehicles with fixed rear spoiler>
1. Liftgate lower trim  
(Refer to GROUP 52A – Trims.)
  2. Rear spoiler  
(Refer to GROUP 51 – Aero Parts.)
  3. High mounted stop light



- <Vehicles with active rear spoiler>
1. Light unit
  2. Socket assembly
  3. Bulb

### Removal steps

1. Liftgate lower trim  
(Refer to GROUP 52A – Trims.)
2. High mounted stop light cover
3. High mounted stop light lens and bracket
4. Gasket

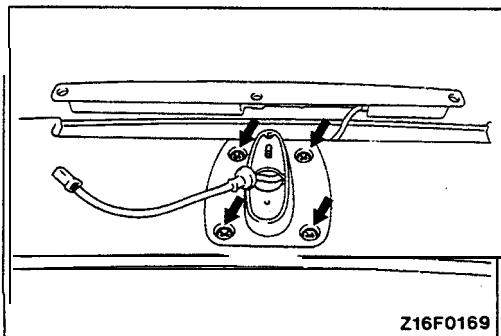

## REMOVAL SERVICE POINT

### 4A, HIGH-MOUNTED STOP LIGHT REMOVAL (Vehicles with fixed rear spoiler)

Remove the air spoiler center stay mounting screws before removing the high-mounted stop light.



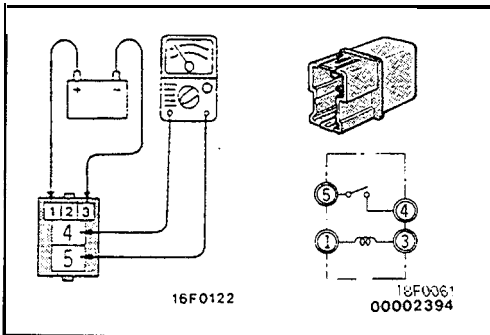

**RELAY**

**INSPECTION**

**HEADLIGHT RELAY / TAILLIGHT RELAY / FOG LIGHT RELAY CHECK**

Connect battery to terminal 1 and check continuity between terminals with terminal 3 grounded.

Power is supplied	4-5 terminals	Continuity
Power is not supplied	4-5 terminals	No continuity
	1-3 terminals	Continuity

**POP-UP MOTOR RELAY (Up to 1993 models) CHECK**

Check for continuity between terminals under the conditions described below.

Battery voltage	Terminal No.						
	1	2	3	4	5	7	8
Continuity no voltage	○	—			○	○	○
			○	—	○		
Continuity with voltage	○	○		⊖	—	⊕	
		○	○			⊕	⊖

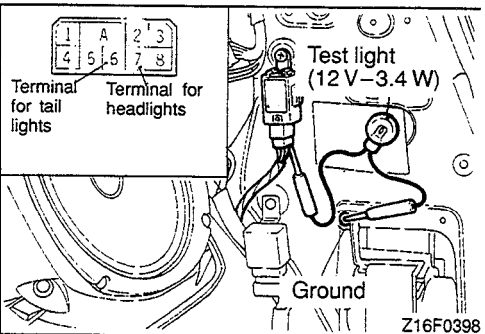
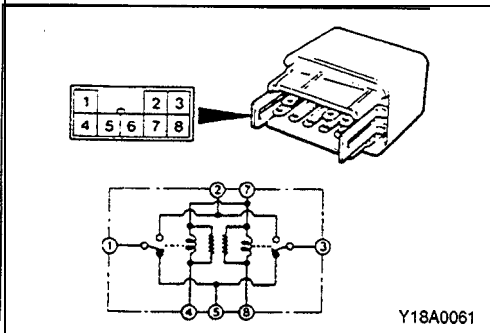

**LIGHT AUTOMATIC SHUT-OFF UNIT CHECK**

- (1) Remove the quarter trim. (Refer to GROUP 52A – Trim.)
- (2) Keeping the connector connected to the light automatic shut-OFF unit, connect the test light (12 V-3.4 W) from the harness side to terminal No. 6 (for tail lights) or No. 7 (for headlights). Under the following conditions, check the operation of the test light.

	Conditions	Test light
(1)	Ignition switch and lighting switch are at "OFF" position.	Illuminated
(2)	Lighting switch is at "TAIL" or "HEAD" with ignition switch at "ACC" or "ON" position.	Illuminated
(3)	Driver's door is opened after ignition switch is turned from state (2) to "OFF" position. (Reverse procedure is also allowable.)	Illuminated
(4)	Ignition switch is once turned from state (3) "OFF", then turned to "TAIL" or "HEAD".	Extinguished
(5)	Ignition switch is turned from state (3) to "ACC" or "ON" position.	Illuminated

**POP-UP SWITCH\* AND FOG LIGHT SWITCH  
REMOVAL AND INSTALLATION**

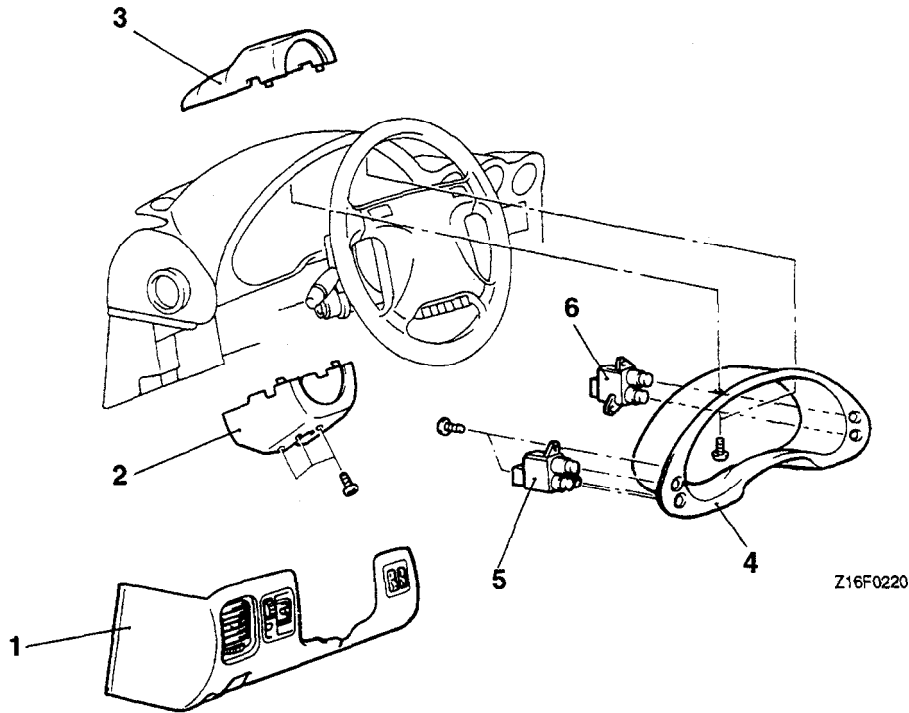

**Removal steps**

1. Knee protector  
(Refer to GROUP 52A – Instrument Panel.)
2. Column cover, lower
3. Column cover, upper
4. Meter bezel

5. Pop-up switch\* and fog light switch
6. Rear window defogger switch

**NOTE**

- :Up to 1993 models



**REMOVAL SERVICE POINTS**

**◀A▶ COLUMN COVER, LOWER / COLUMN COVER, UPPER REMOVAL**

After the screws have been removed, remove the covers, while making sure not to break the grippers.

**INSPECTION**

Operate the switch to check for continuity between terminals.

Switch position		Terminal No.						
		1	5	8	9	10	3	4
Pop-up switch (Up to 1993 models)	UP				○	○	Illumination light	
	DOWN			○	○	○		
Fog light switch	ON	○	○					
	OFF							

**NOTE**

Refer to P.54-203. Check the rear window defogger switch.

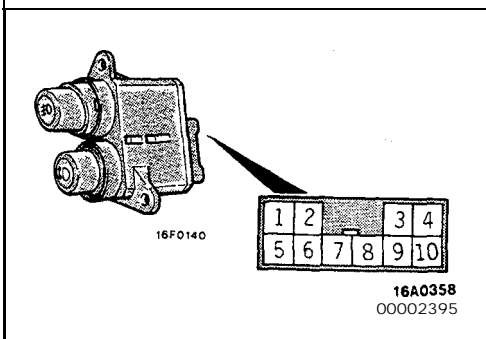
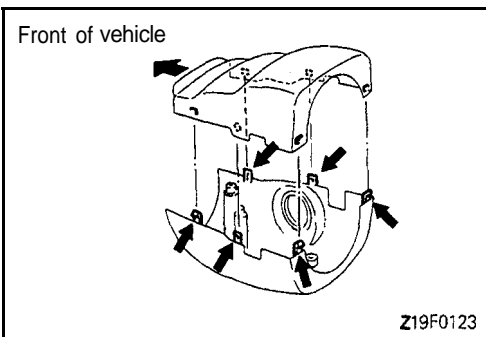

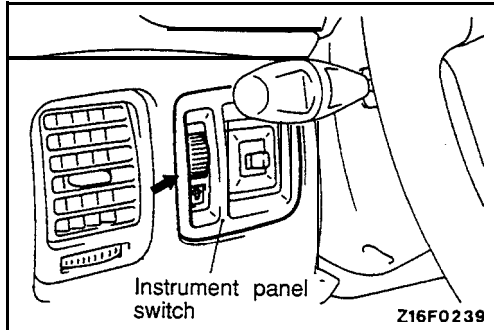

**RHEOSTAT  
INSPECTION**

(1) Remove the instrument panel switch from the knee protector.

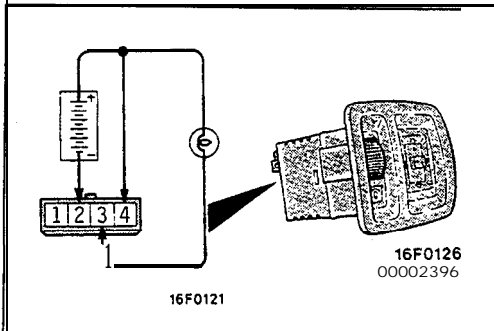

(2) Connect the battery and a test bulb (40 W) as shown in the figure.

(3) The function of the rheostat is normal if the intensity of illumination changes smoothly, without flashing or flickering, when the rheostat is operated.

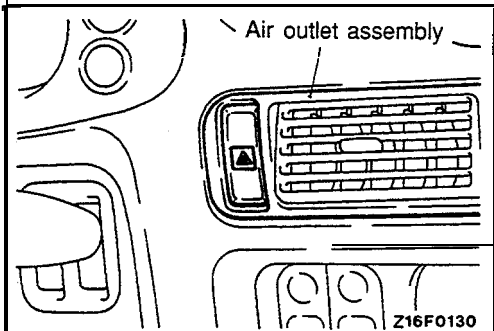

**HAZARD SWITCH  
INSPECTION**

(1) Remove the center air outlet assembly from instrument panel. [Refer to GROUP 55 – Ventilators (Instrument Panel).]

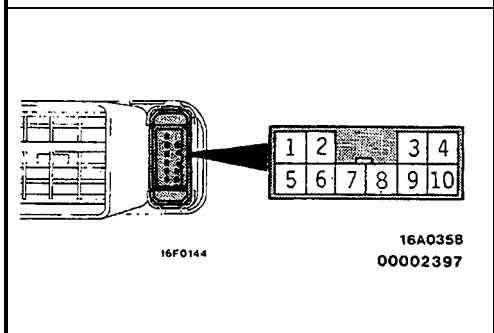

(2) Operate the switch to check for continuity between terminals.

Switch position	Terminal No.									
	1	5	6	7	8	9	10	2	3	
ON			○			○	○			
OFF		○			○				○	

Illumination light

**COLUMN SWITCH****SPECIFICATIONS****GENERAL SPECIFICATIONS**

Items		Specifications
Lighting switch	Rated load A	0.22 ± 0.05
	Voltage drop V	0.2 or less
Turn-signal switch	Rated load A	6.6 ± 0.5
	Voltage drop V	0.2 or less
Dimmer/passing switch	Rated load A	High beam : 10.7 ± 0.8
		Low beam : 9.8 ± 0.7
		Passing : 20.5 ± 1.5
	Voltage drop V	0.2 or less

**NOTE**

For the wiper and washer switch, refer to GROUP 51 – Windshield Wiper and Washer.

**SPECIAL TOOL**

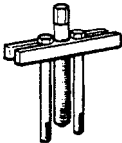
Tool	Tool number and name	Supersession	Application
	MB990803 Steering wheel puller	General service tool	Removal of steering wheel

## COLUMN SWITCH

## REMOVAL AND INSTALLATION

**CAUTION: SRS**

Before removal of air bag module, refer to GROUP 52B – Service Precautions and Air Bag Module and Clock Spring.

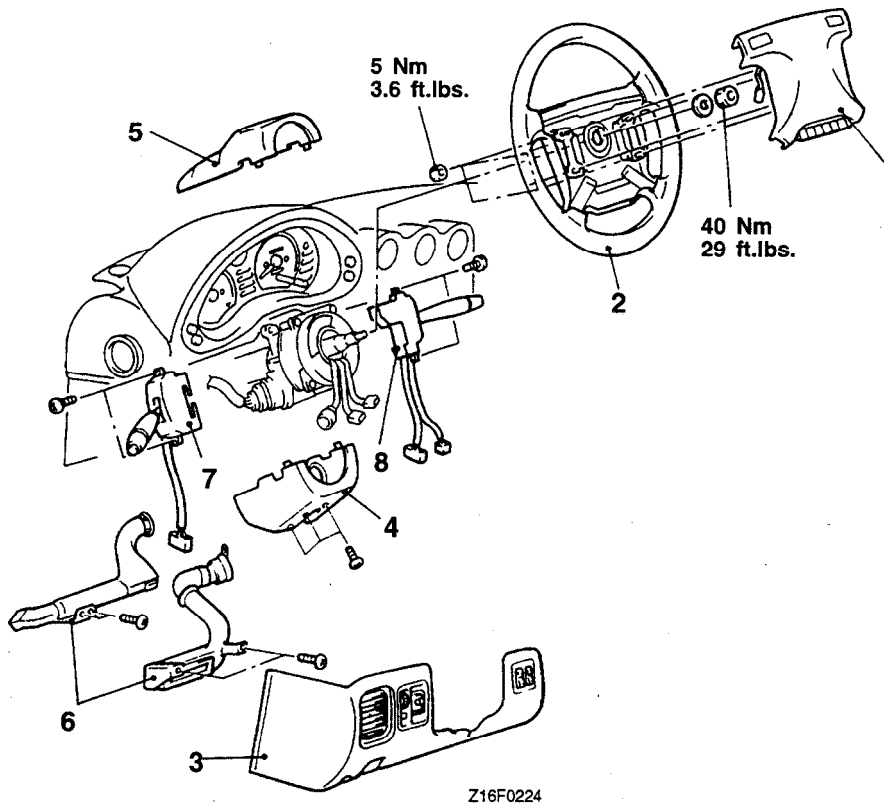
**Removal steps**

- |                           |  |            |   |
|---------------------------|--|------------|---|
| <p>◀A▶ ▶A▶</p> <p>◀B▶</p> | <ol style="list-style-type: none"> <li>1. Air bag module (Refer to GROUP 52B–Air Bag Module and Clock Spring.)</li> <li>2. Steering wheel</li> <li>3. Knee protector (Refer to GROUP 52A – Instrument Panel.)</li> <li>4. Column cover, lower</li> </ol> | <p>◀B▶</p> | <ol style="list-style-type: none"> <li>5. Column cover, upper</li> <li>6. Lap cooler duct and foot shower duct</li> <li>7. Column switch, right (For lighting switch, dimmer/passing switch and turn signal switch)</li> <li>8. Column switch, right (For wiper and washer switch)</li> </ol> |
|---------------------------|--|------------|---|

**REMOVAL SERVICE POINTS****◀A▶ STEERING WHEEL REMOVAL**

Remove the steering wheel by the special tool.

**Caution**

Do not hammer on the steering wheel. Doing so may damage the collapsible column mechanism.

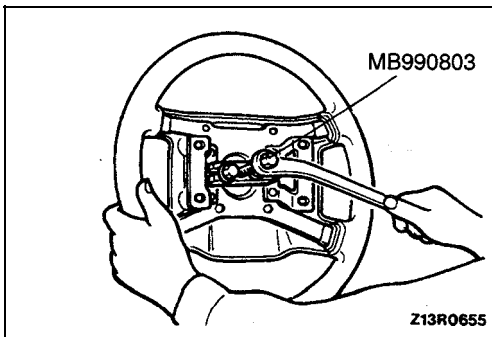

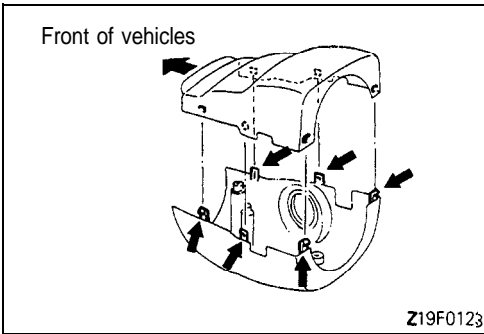

◀B▶ **COLUMN COVER, LOWER / COLUMN COVER, UPPER REMOVAL**

After the screws have been removed, remove the covers, while making sure not to break the grippers.

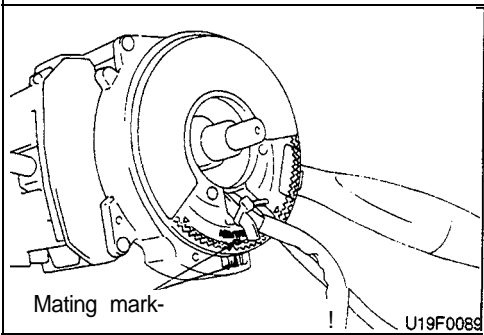

**INSTALLATION SERVICE POINT**

▶A▶ **STEERING WHEEL INSTALLATION**

To center the clock spring, line up the "NEUTRAL" mark of the clock spring with the mating mark.

**Caution**

If the clock spring's mating mark is not properly aligned, the steering wheel may not be completely rotational during a turn, or the flat cable within the clock spring may be severed, obstructing normal operation of the SRS and possibly leading to serious injury to the vehicle's driver.

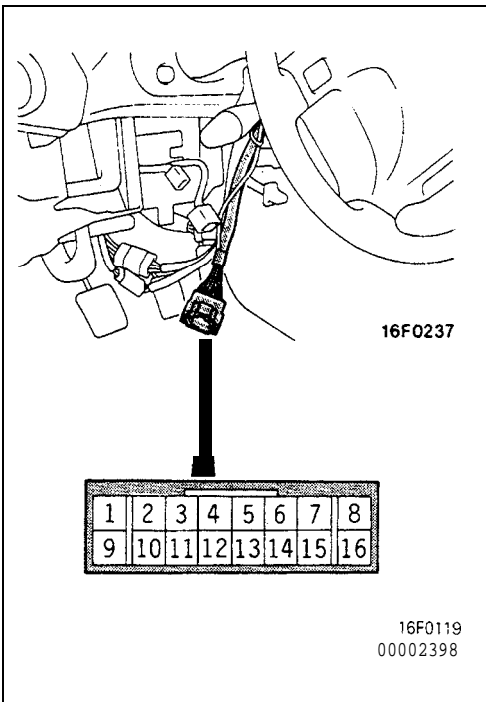

**INSPECTION**

- (1) Remove the knee protector and the column cover. (Refer to GROUP 52A – Instrument Panel.)
- (2) Disconnect the column switch left connector (16 terminals) and check the continuity between the terminals for each switch.

**LIGHTING SWITCH CHECK**

Operate the switch and check the continuity between the terminals.

Switch position	Terminal No.					
	3	5	6	7	10	14
OFF		○—○				
☰		○—○			○—○	
☷	○—			○—	○—○	

**TURN SIGNAL SWITCH CHECK**

Operate the switch and check the continuity between the terminals.

Switch position	Terminal No.		
	1	12	13
Left	○	—	○
Neutral			
Right	○	○	

**DIMMER/PASSING SWITCH CHECK**

Operate the switch and check the continuity between the terminals.

Switch position		Terminal No.			
		2	8	9	16
Dimmer switch	LOW			○	○
	HIGH		○	○	
Passing switch		○	○	○	

**WIPER AND WASHER SWITCH**

Refer to GROUP 51 – Windshield Wiper and Washer.

# HORN

## SPECIFICATIONS

### GENERAL SPECIFICATIONS

Horn (Except for theft-alarm horn)

Items	Specifications	
Type	Flat type	
Effective sounding voltage V	11.5–15	
Power consumption A	3.0	
Sound level dB	“low” sound	100–112
	“high” sound	100–112
Fundamental frequency Hz	“low” sound	350–390
	“high” sound	395–435

### Theft-alarm horn

Items	Specifications	
Type	Flat type	
Effective sounding voltage V	11–14.5	
Power consumption A	Max. 3.5	
Sound level dB	105–120	
Fundamental frequency Hz	405–435	

## TROUBLESHOOTING

### COMPONENT LOCATION

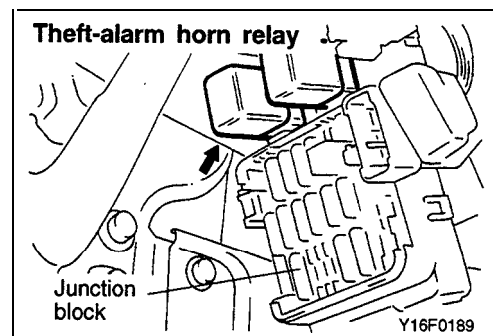
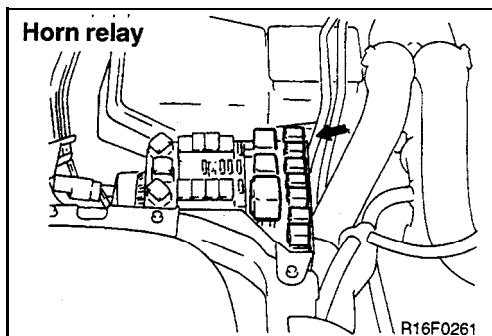

### OPERATION

- The horn switch always receives battery voltage via the dedicated fuse (6) and the coil of the horn relay.
- When the horn switch is set to ON, the contacts of the horn relay close. Then current flows through the dedicated fuse (6) to the contacts of the horn relay, the horn and ground, causing the horn to sound.

### TROUBLESHOOTING HINTS

1. One of the horn does not sound.
  - Check the horn.
2. Horns do not sound.
  - Check the horn switch.
  - Check the dedicated fuse (6).

### NOTE

- (1) For vehicles equipped with the theft-alarm system, refer to P.54-205.
- (2) For information concerning the horn relay and theft-alarm horn relay, refer to P.54-118.



CIRCUIT DIAGRAM

<VEHICLES WITHOUT THEFT-ALARM SYSTEM>

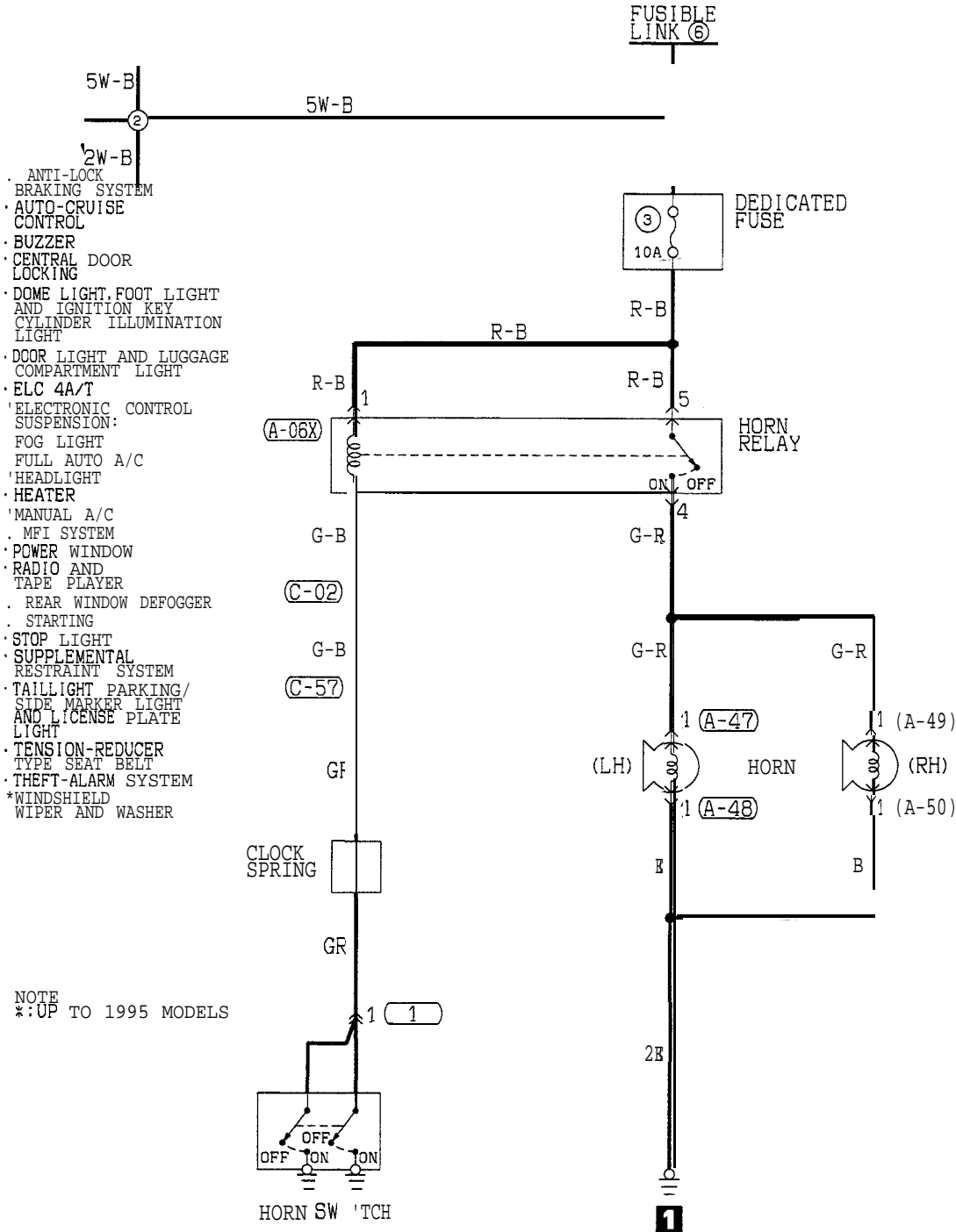

NOTE  
\*: UP TO 1995 MODELS

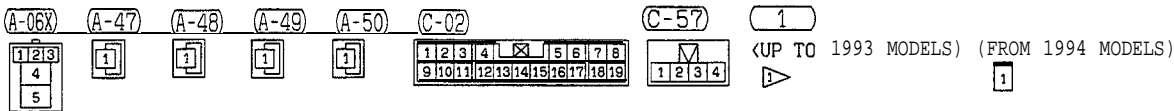

<VEHICLES WITH THEFT-ALARM SYSTEM>

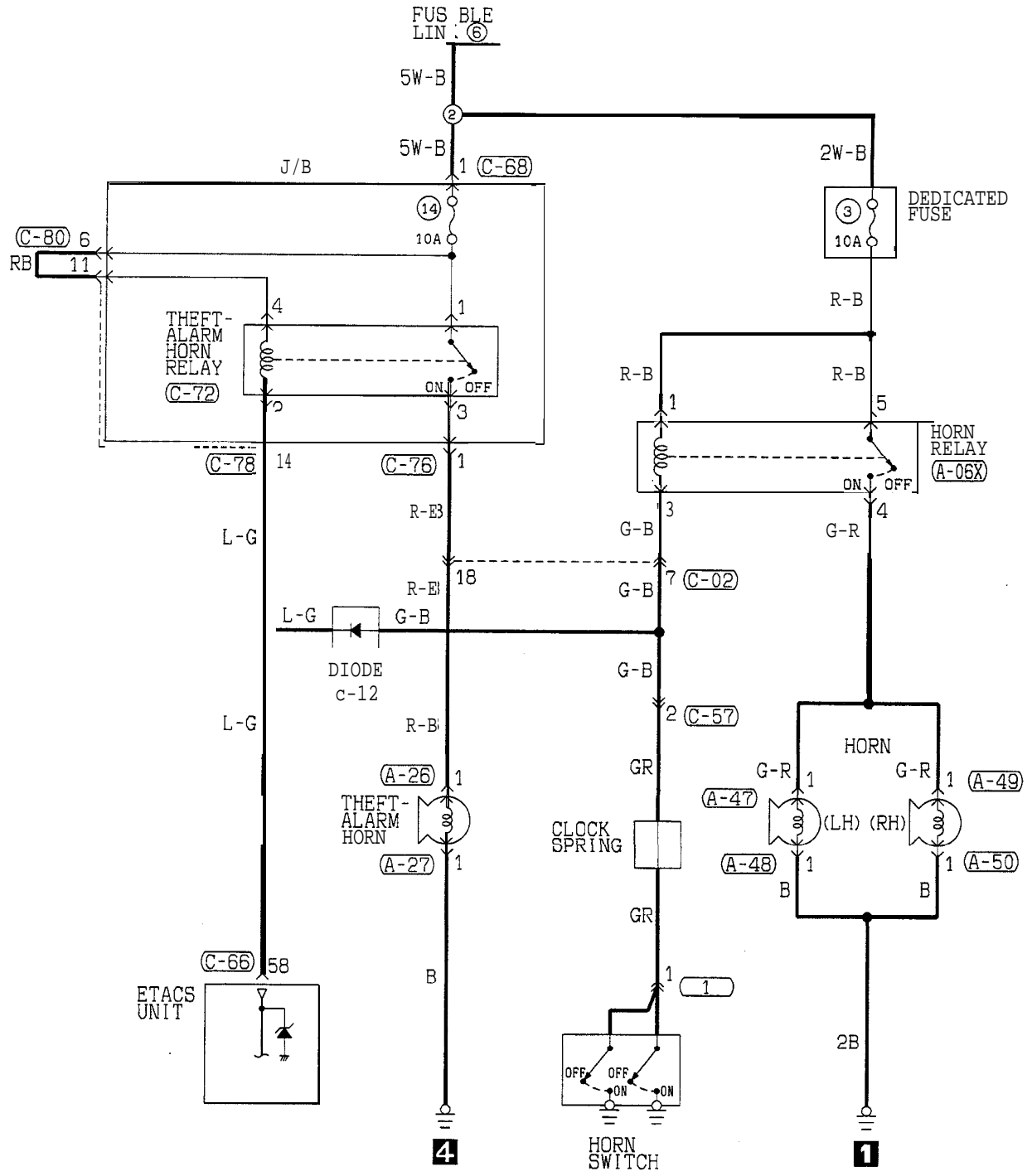

(A-06X)	(A-26)	(A-27)	(A-47)	(A-48)	(A-49)	(A-50)	(C-02)	(C-57)	(C-66)	(C-68)
1 2 3 4 5	1	1	1	1	1	1	1 2 3 4 5 6 7 8 9 10 11 12 13 14 15 16 17 18 19	1 2 3 4	5 1 5 2 5 3 5 4 5 5 5 6 5 7 5 8 5 9 6 0 6 1 6 2 6 3 6 4 6 5 6 6	1
(C-72)	(C-76)	(C-78)	(C-80)	(1)	(UP TO 1993 MODELS) (FROM 1994 MODELS)					
1 2 3 4	1 2 3 4	1 2 3 4 5 6 7 8 9 10 11 12 13 14	1 2 3 4 5 6	1						

TSB Revision

# HORN SWITCH

## REMOVAL AND INSTALLATION

**CAUTION: SRS**

Before removal of air bag module, refer to GROUP 52B – Service Precautions and Air Bag Module and Clock Spring.

(UP TO 1993 MODELS)

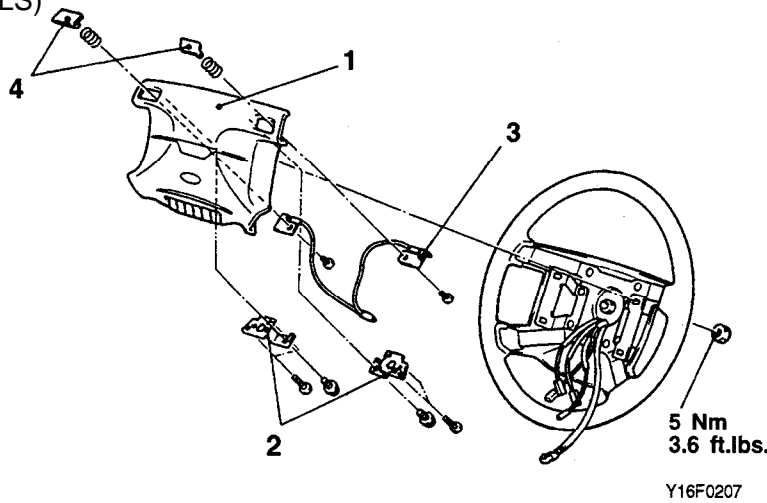

**Removal steps**

1. Air bag module (Refer to GROUP 52B – Air Bag Module and Clock Spring.)
2. Horn contact switch
3. Horn contact plate and wire
4. Horn switch

(FROM 1994 MODELS)

The horn switch is not supplied by itself. If it is faulty, replace the steering wheel assembly.

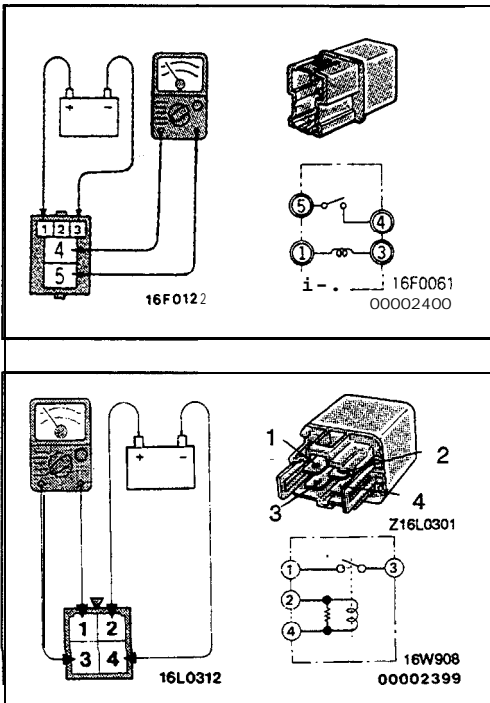

## RELAY

### INSPECTION

#### HORN RELAY CHECK

Connect battery to terminal 1 and check continuity between terminals with terminal 3 grounded.

Power is supplied	4–5 terminals	Continuity
Power is not supplied	4–5 terminals	No continuity
	1–3 terminals	Continuity

#### THEFT-ALARM HORN RELAY CHECK

Connect battery to terminal 2 and check continuity between terminals with terminal 4 grounded.

Power is supplied	1–3 terminals	Continuity
Power is not supplied	1–3 terminals	No continuity
	2–4 terminals	Continuity

# CIGARETTE LIGHTER

## SPECIFICATIONS

### GENERAL SPECIFICATIONS

Items	Specifications
Max. input W	120
Reset time second	Within 18
Thermal fuse fusion temperature °C (°F)	180–250 (356–482)

TROUBLESHOOTING

CIRCUIT DIAGRAM <UP TO 1995 MODELS>

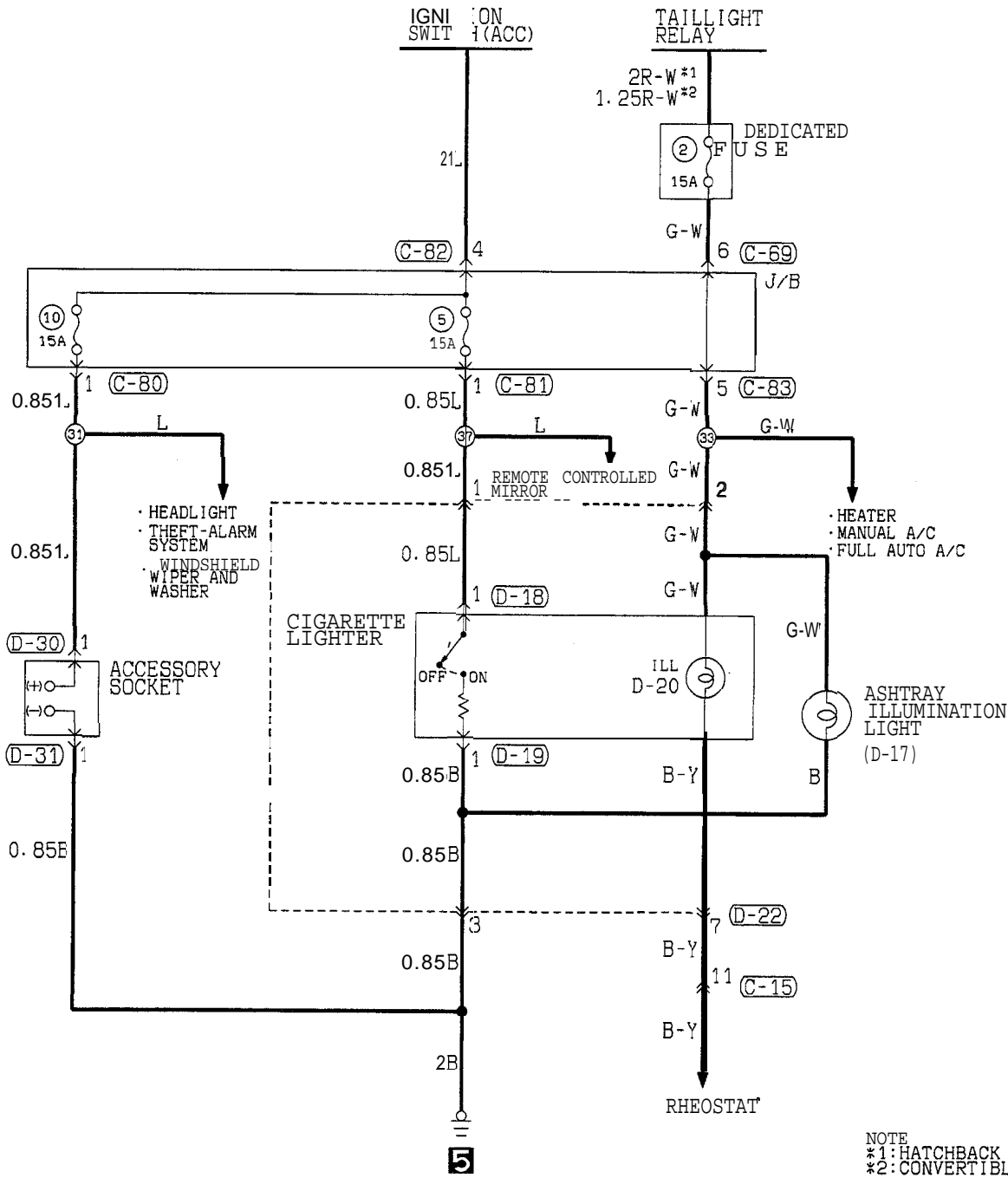

NOTE  
 \*1: HATCHBACK  
 \*2: CONVERTIBLE

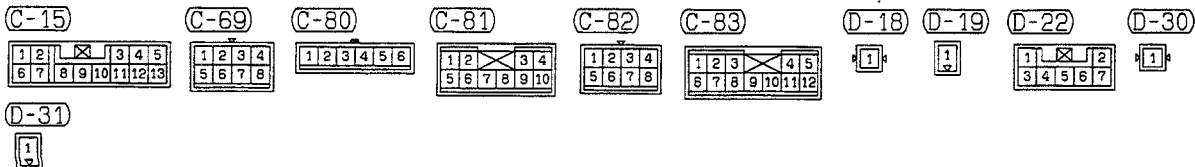

CIRCUIT DIAGRAM <FROM 1996 MODELS>

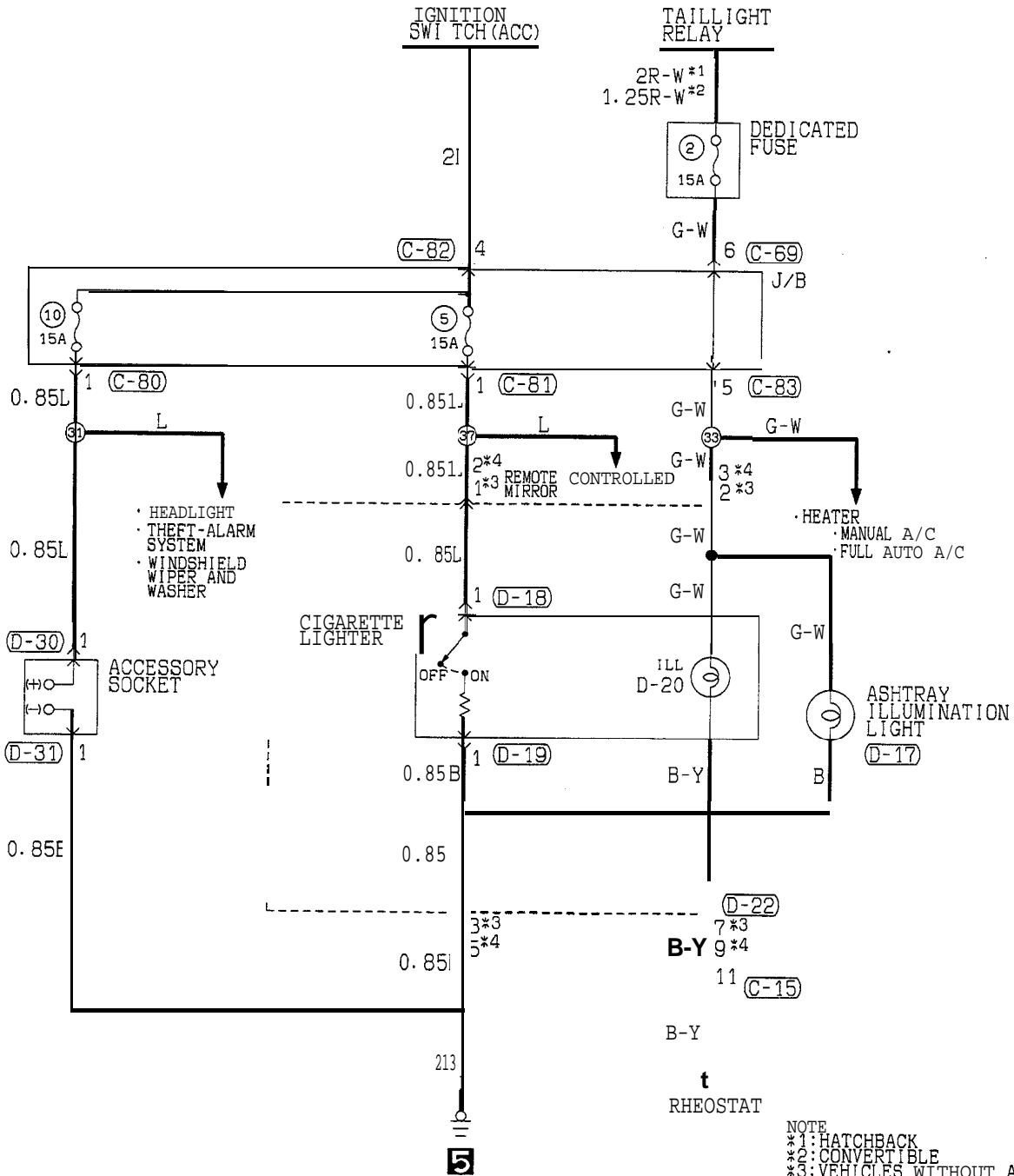

NOTE  
 \*1: HATCHBACK  
 \*2: CONVERTIBLE  
 \*3: VEHICLES WITHOUT ABS  
 \*4: VEHICLES WITH ABS

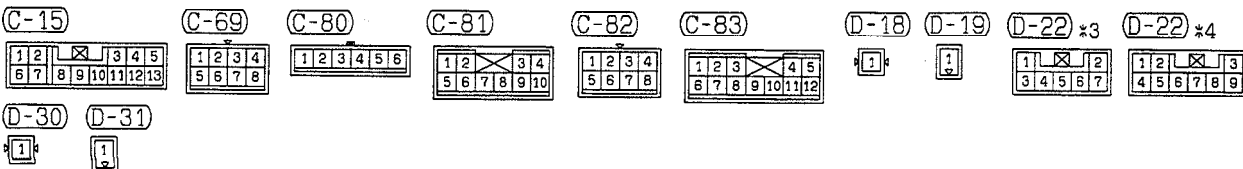

TSB Revision

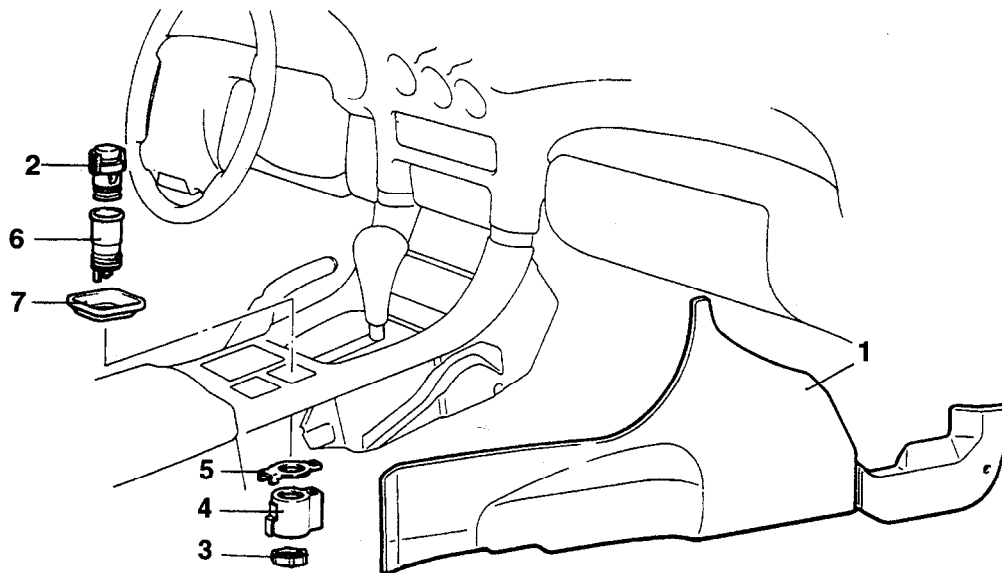

**CIGARETTE LIGHTER****REMOVAL AND INSTALLATION**

Z16F0274

**Removal steps**

1. Console side cover (RH)
2. Plug
3. Fixing ring
4. Socket case

5. Plate
6. Socket
7. Protector

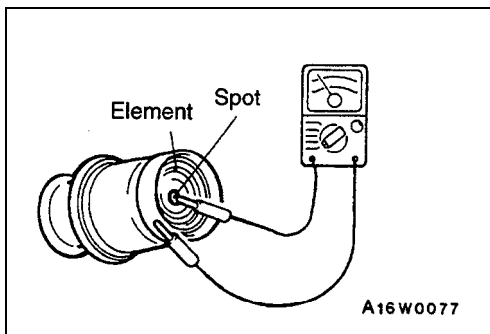
**INSPECTION**

- Take out the plug, and check for a worn edge on the element spot connection, and for shreds of tobacco or other material on the element.
- Using an ohmmeter, check the continuity of the element.



# RADIO AND TAPE PLAYER

## TROUBLESHOOTING

### CIRCUIT DIAGRAM (1992 model)

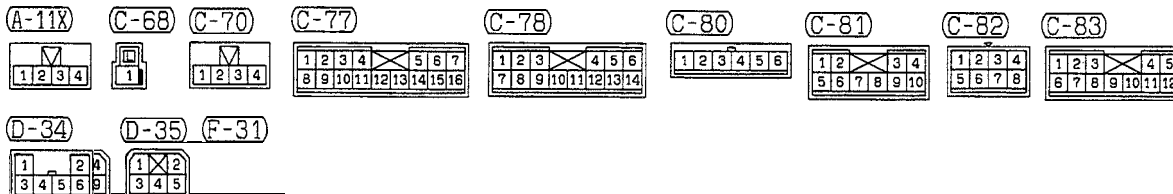
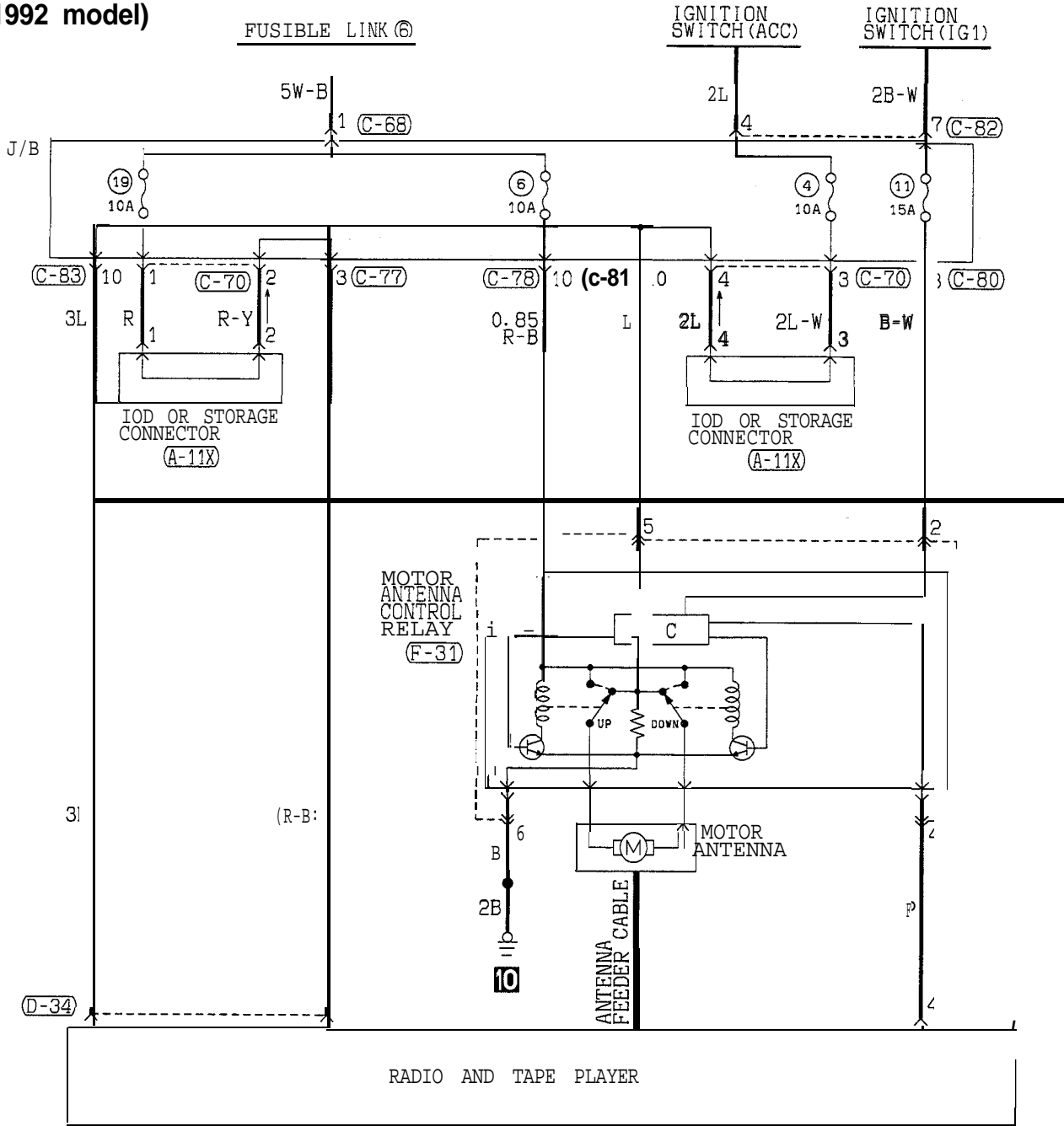

TSB Revision

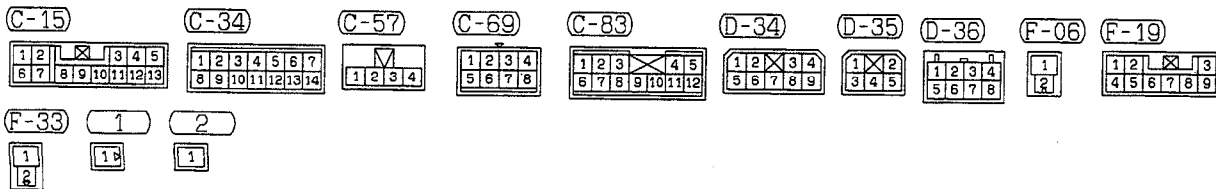
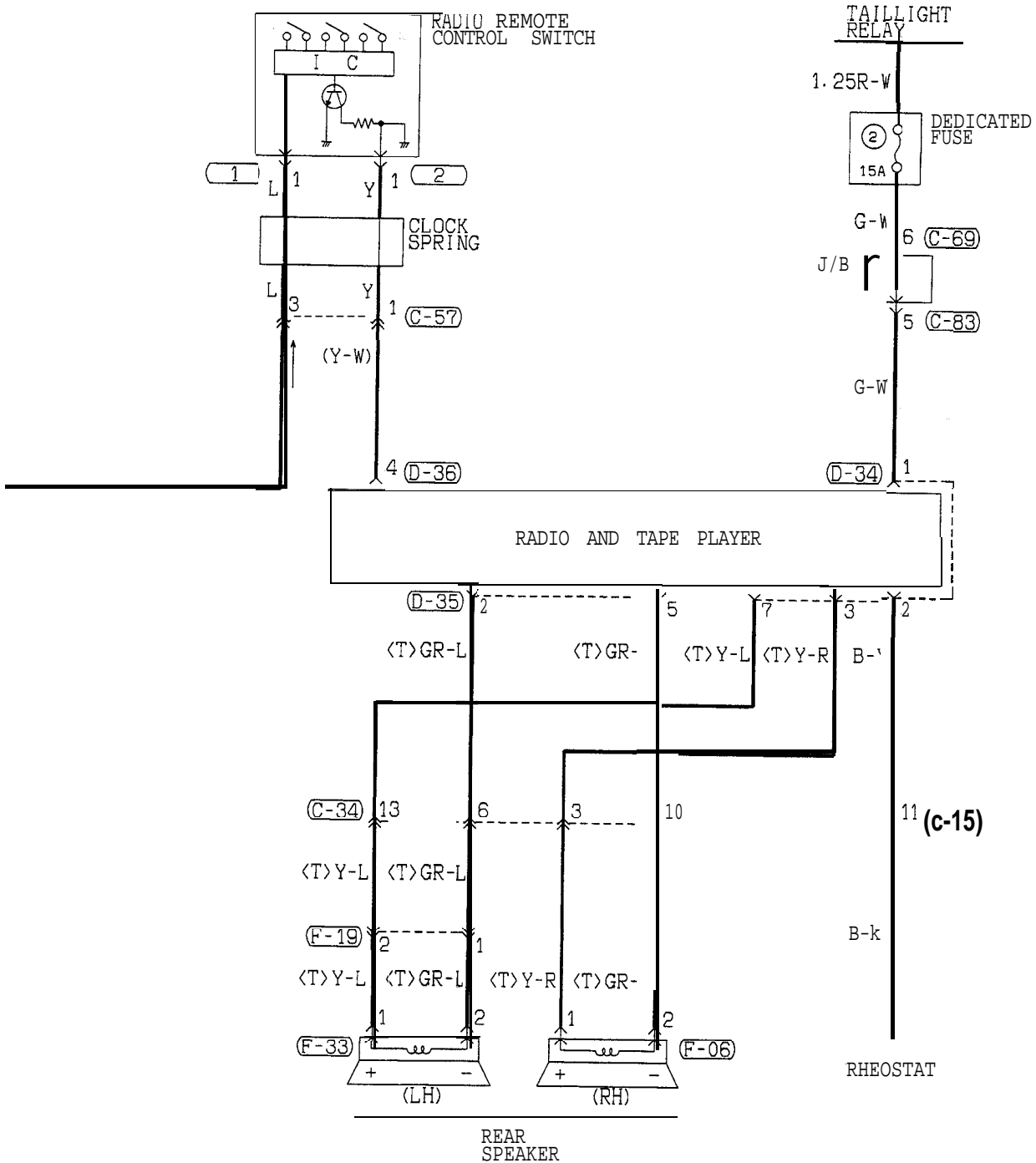

CIRCUIT DIAGRAM (1992 model) (CONTINUED)

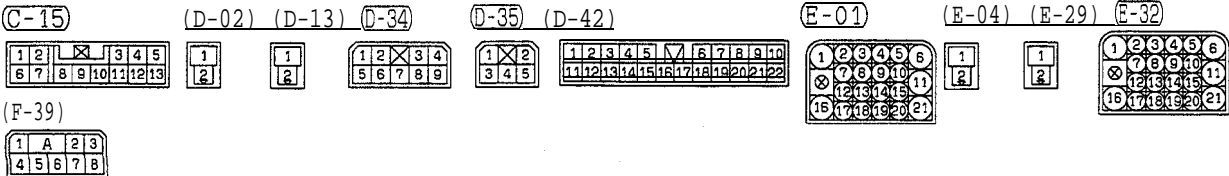
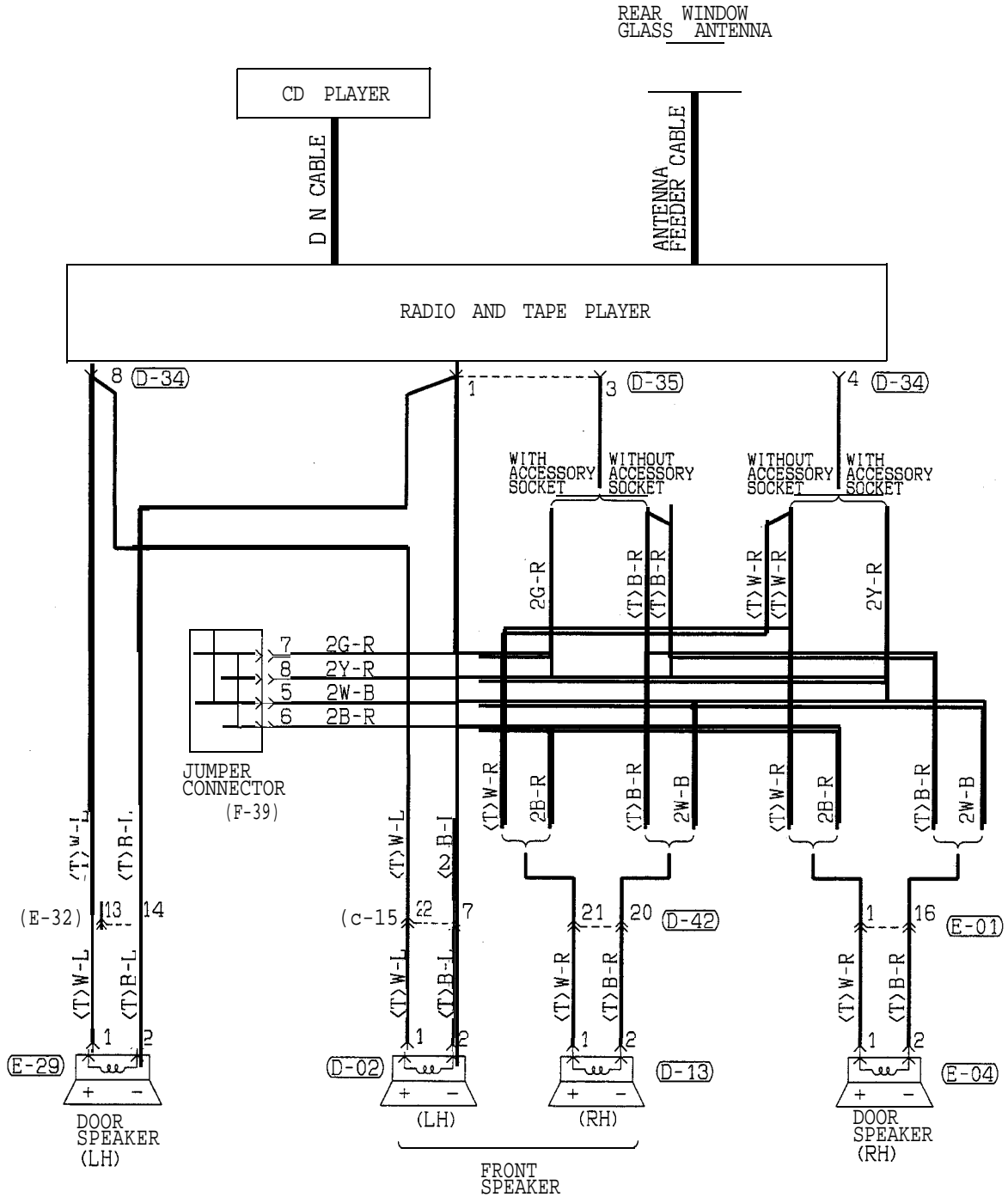

---

NOTES

CIRCUIT DIAGRAM  
(1993 models)

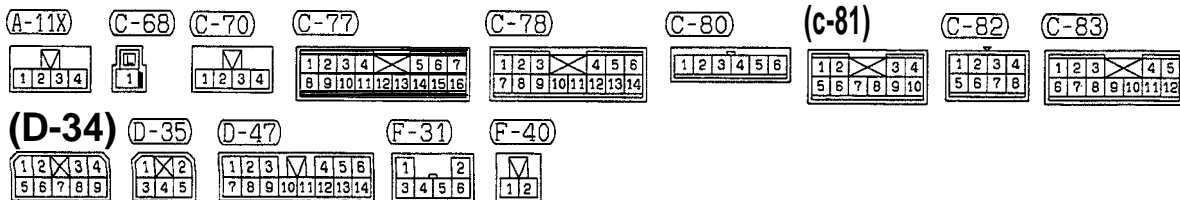
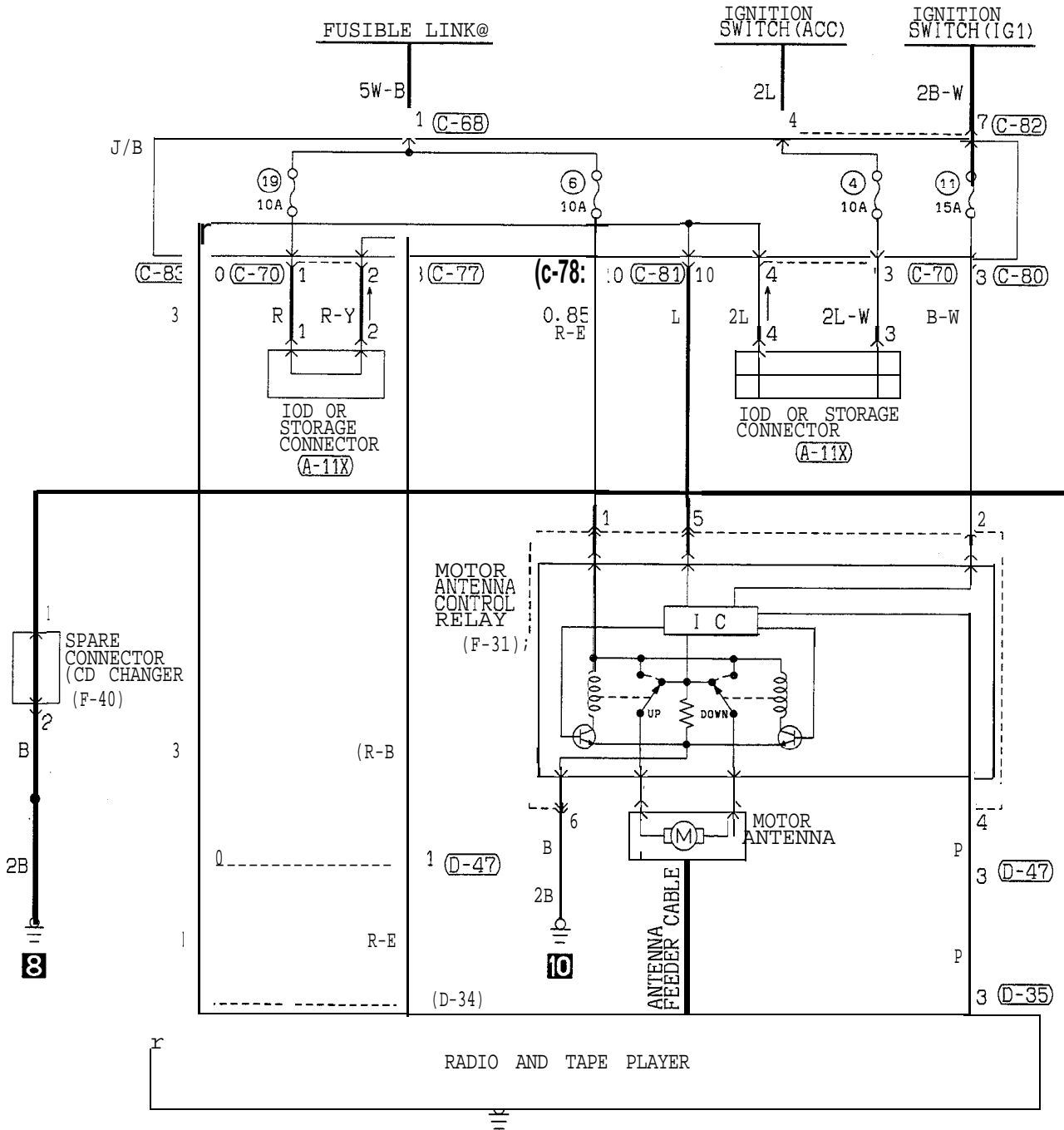

HR14M01AA

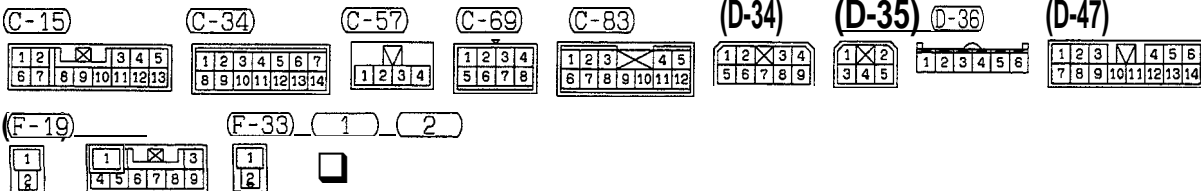
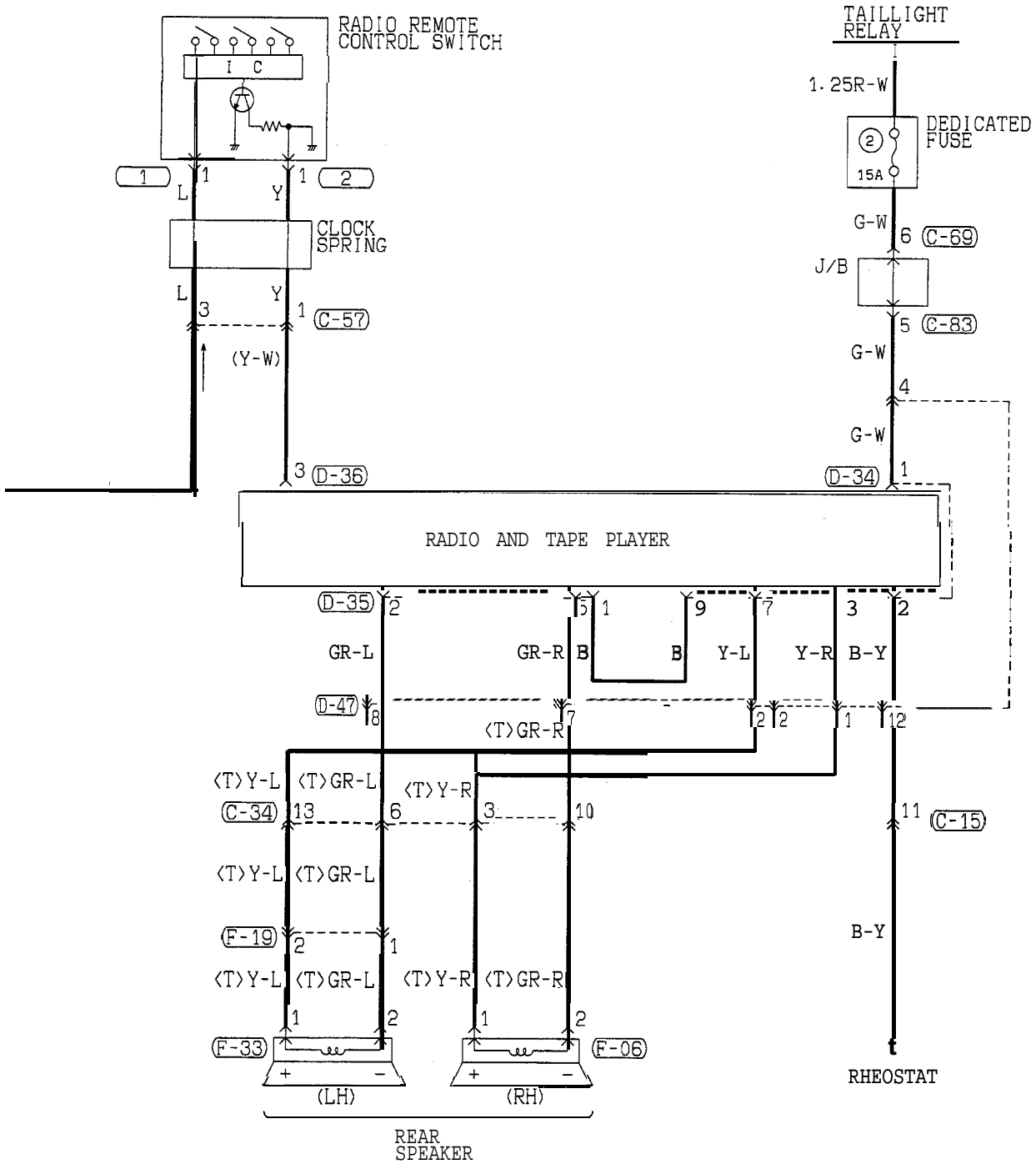

HR14M01AB

CIRCUIT DIAGRAM (1993 models) (CONTINUED)

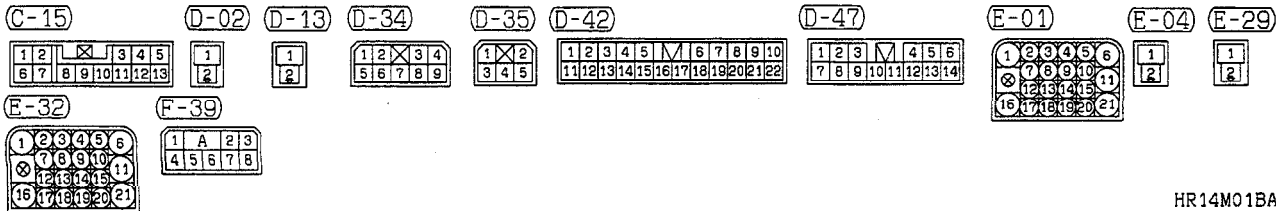
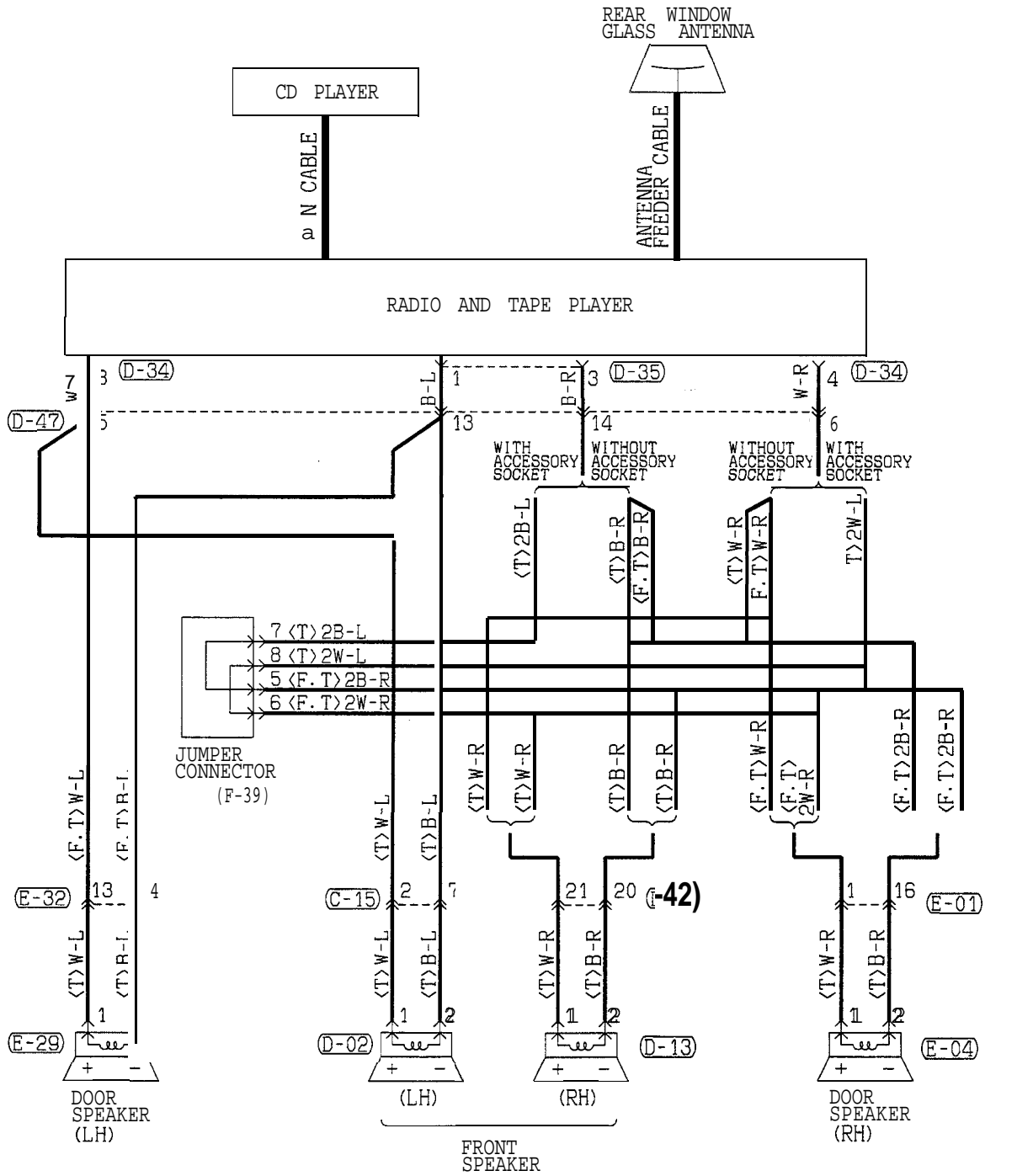

---

NOTES



**CIRCUIT DIAGRAM**  
**(1994 models-Radio and Tape Player with Amplifier)**

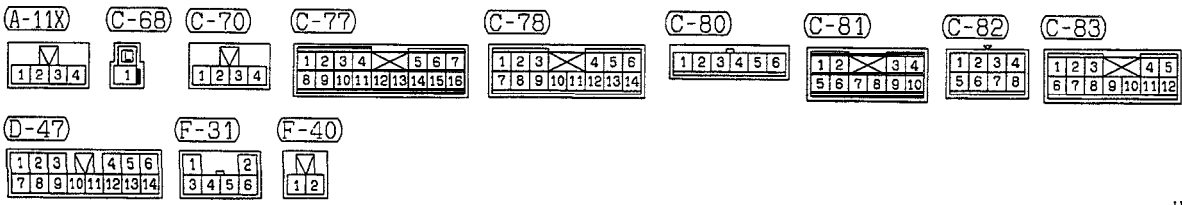
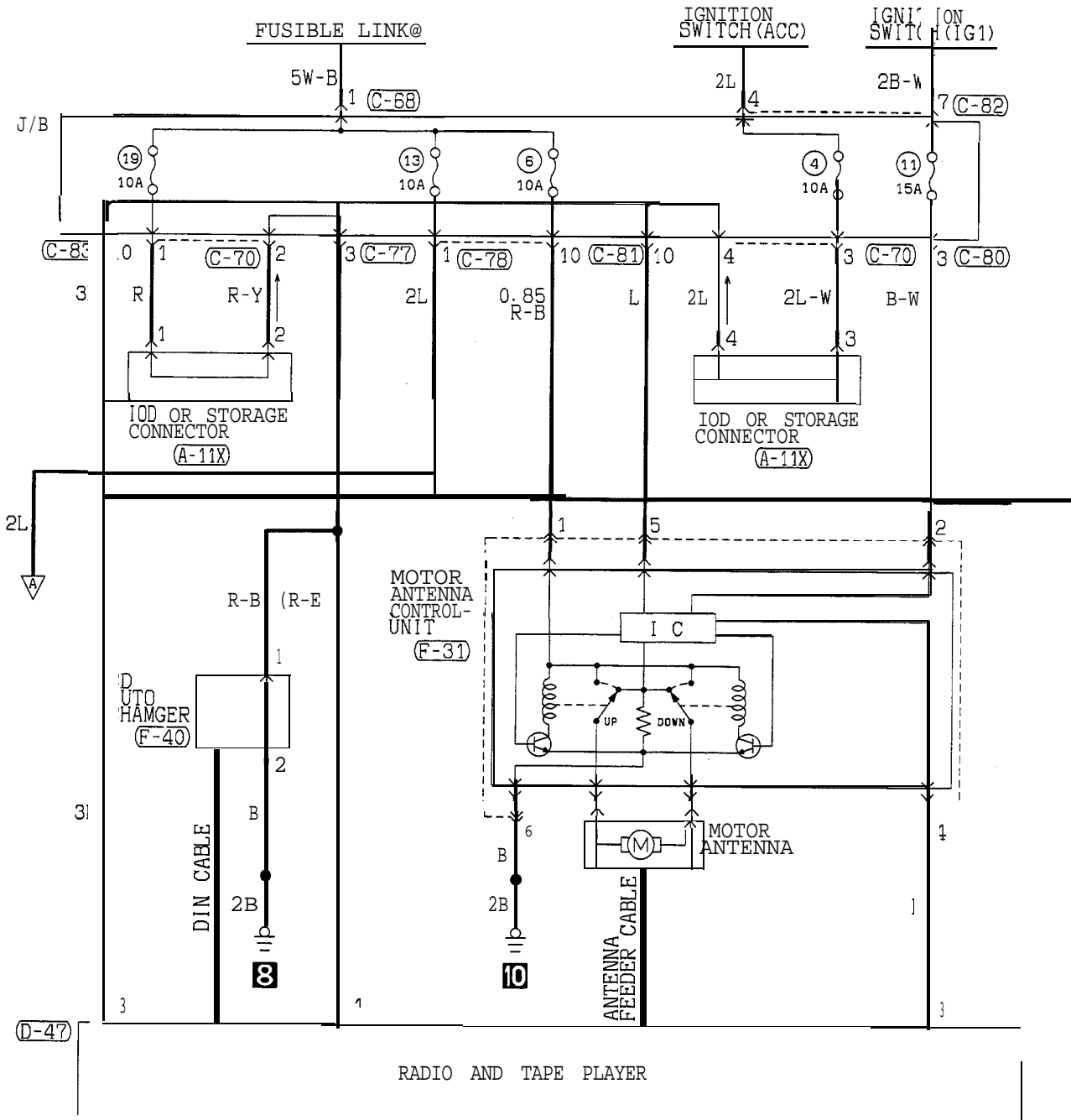

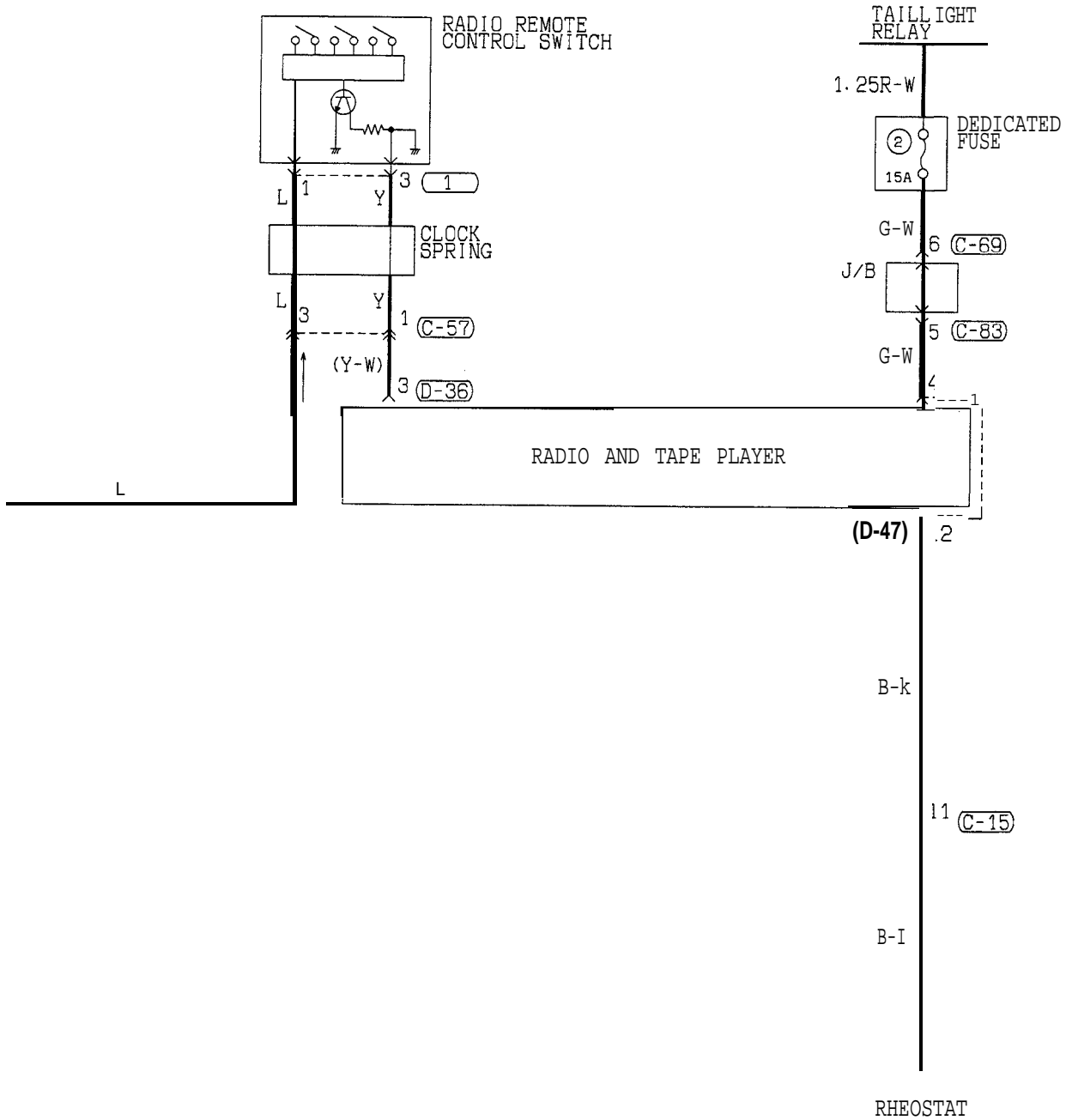

(C-15)

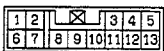

(C-57)



(C-69)



(C-83)



(D-36)

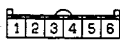

(D-47)

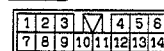

(1)

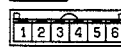

CIRCUIT DIAGRAM (From 1994 models-Radio and Tape Player with Amplifier) (CONTINUED)

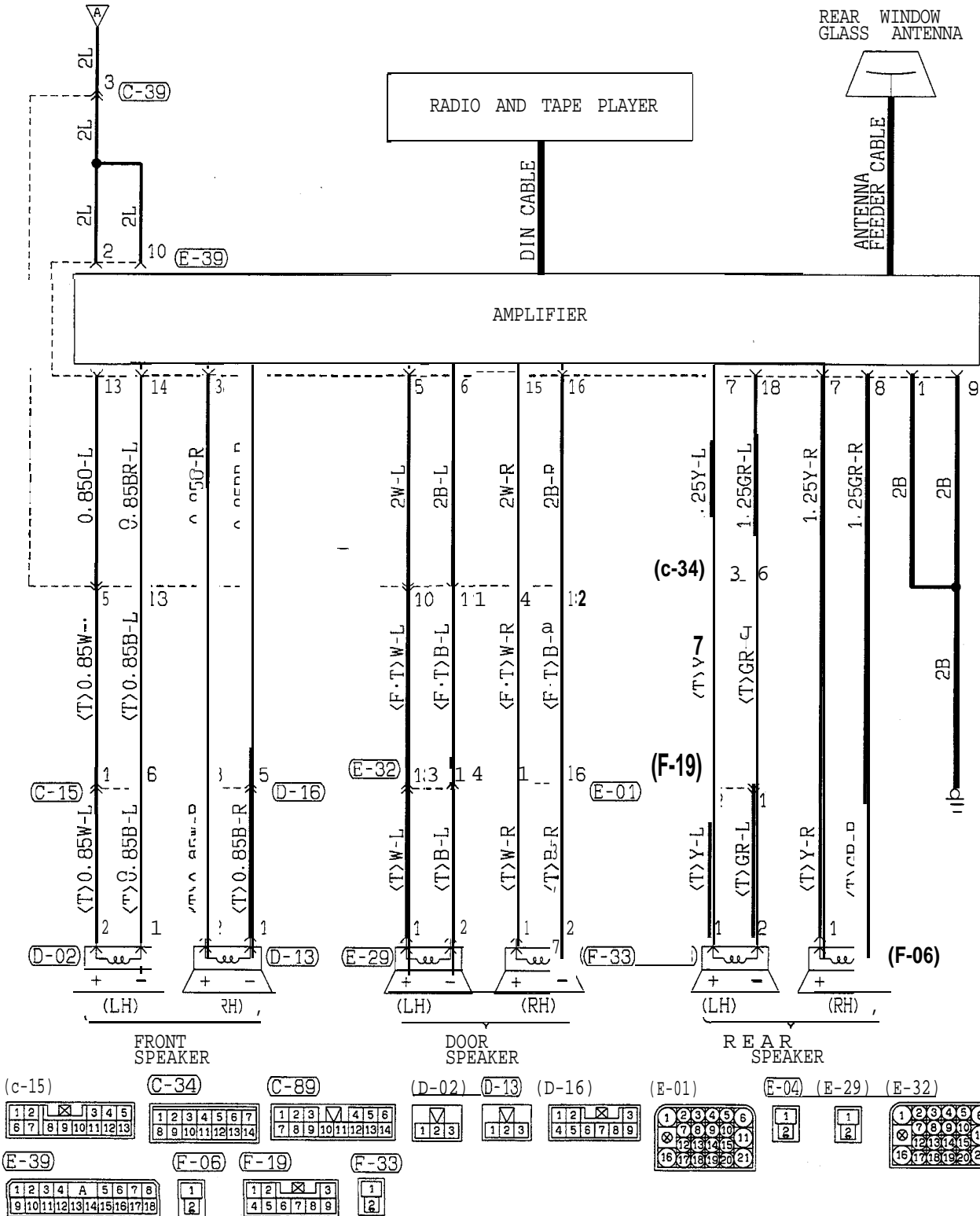

TSB Revision

NOTES

CIRCUIT DIAGRAM

<Hatchback (From 1994 models-Radio and Tape Player without Amplifier)>

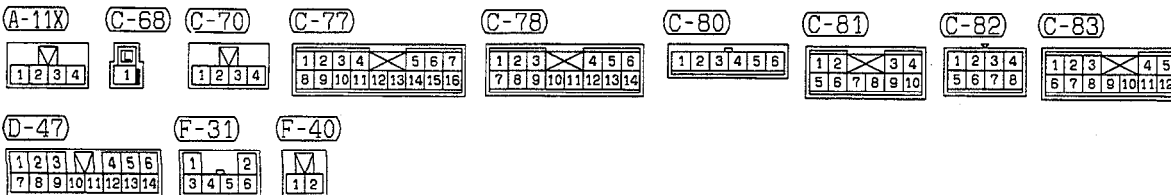
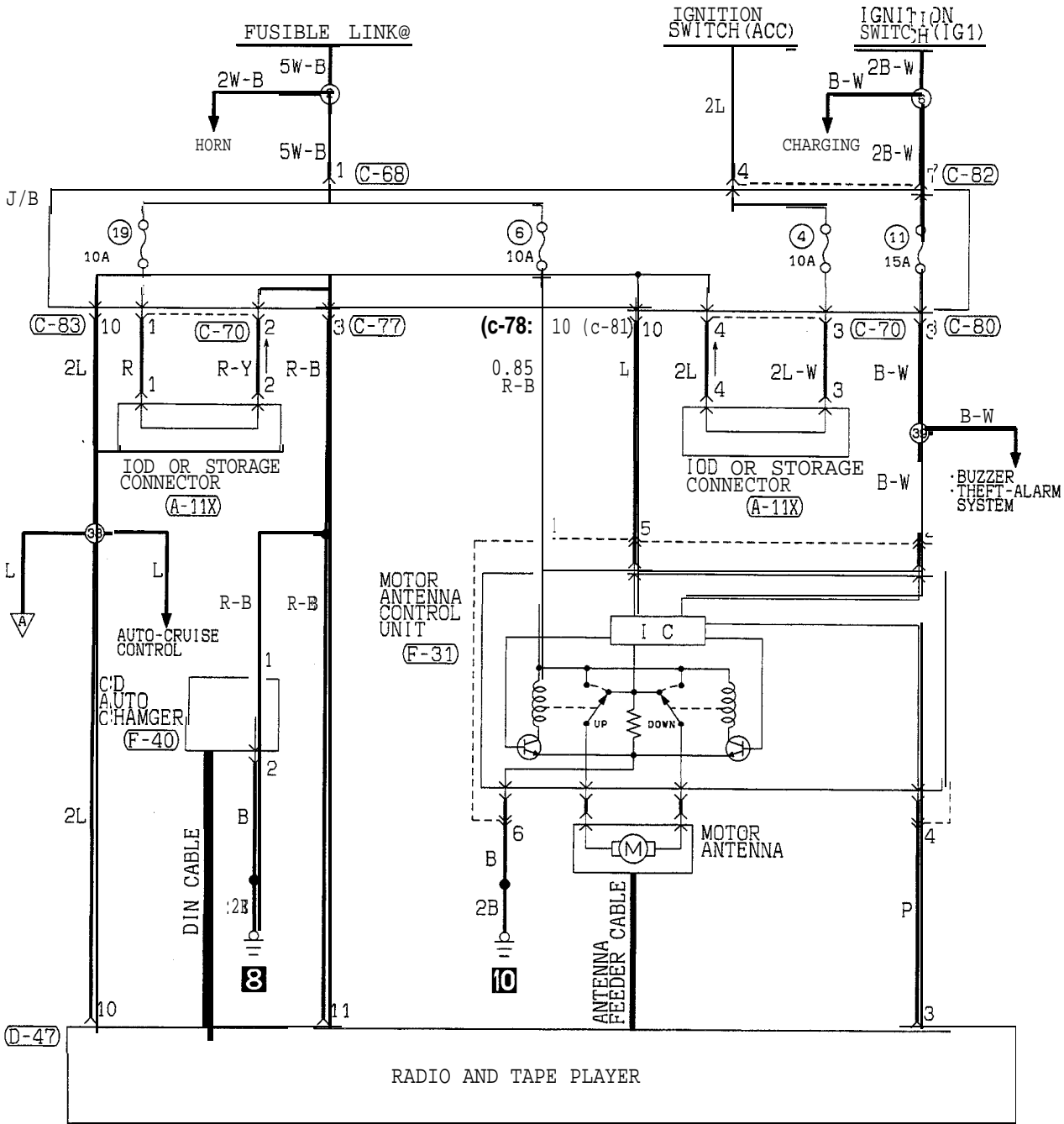

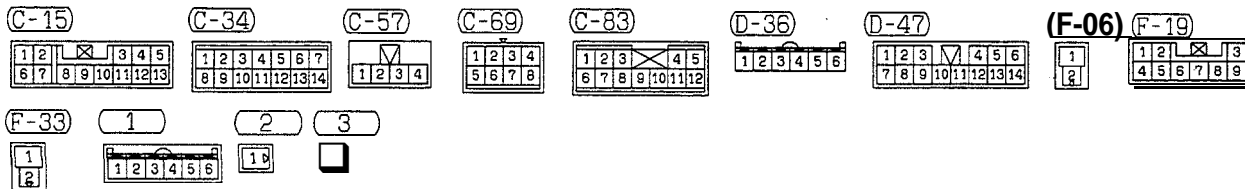
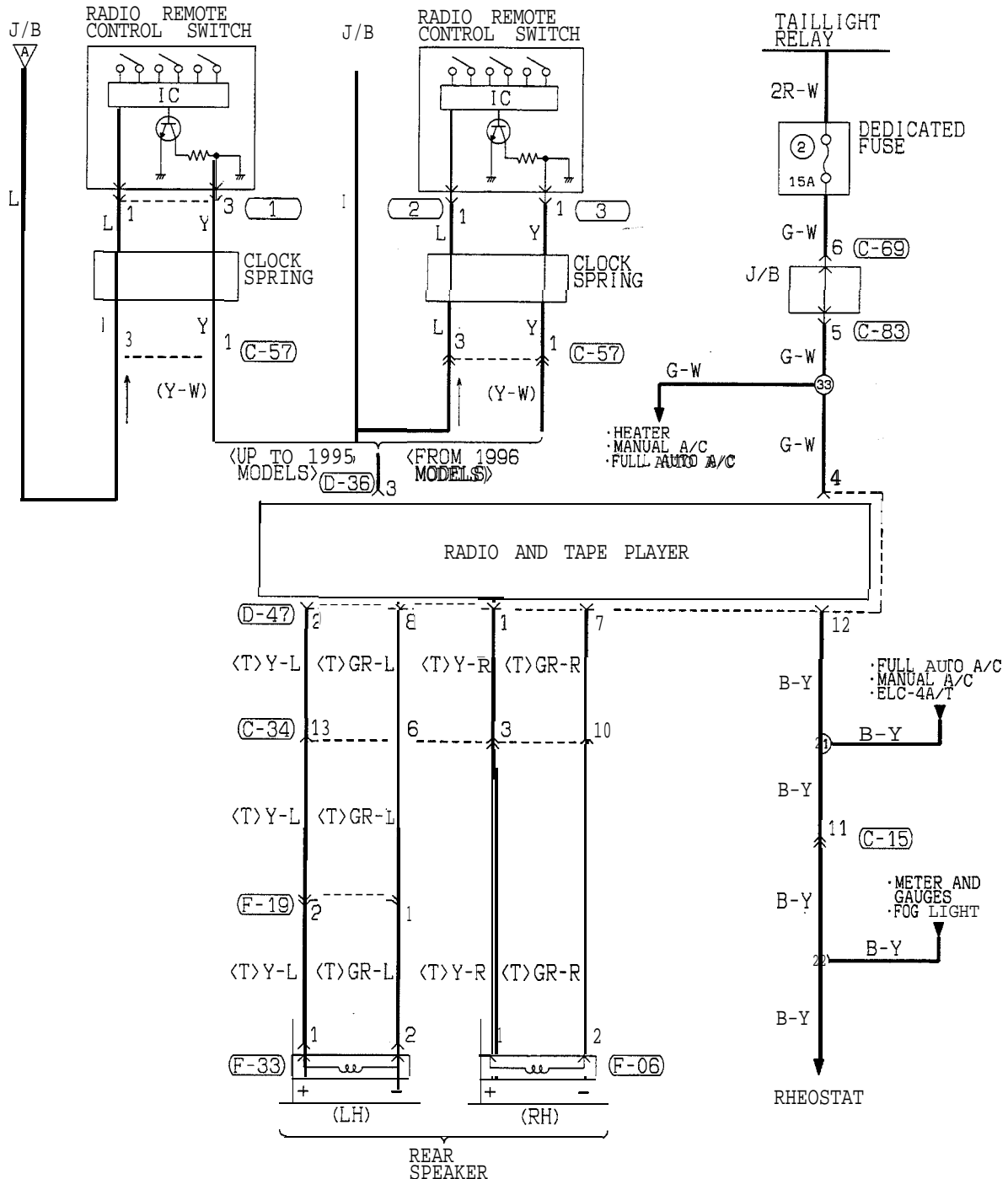

HR14M03AB

TSB Revision

CIRCUIT DIAGRAM <Hatchback (From 1994 models-Radio and Tape Player without Amplifier)>  
(CONTINUED)

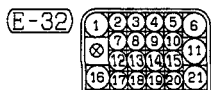
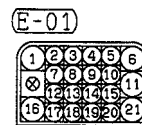
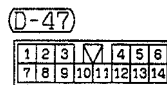
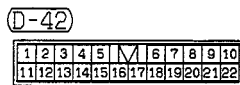
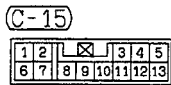
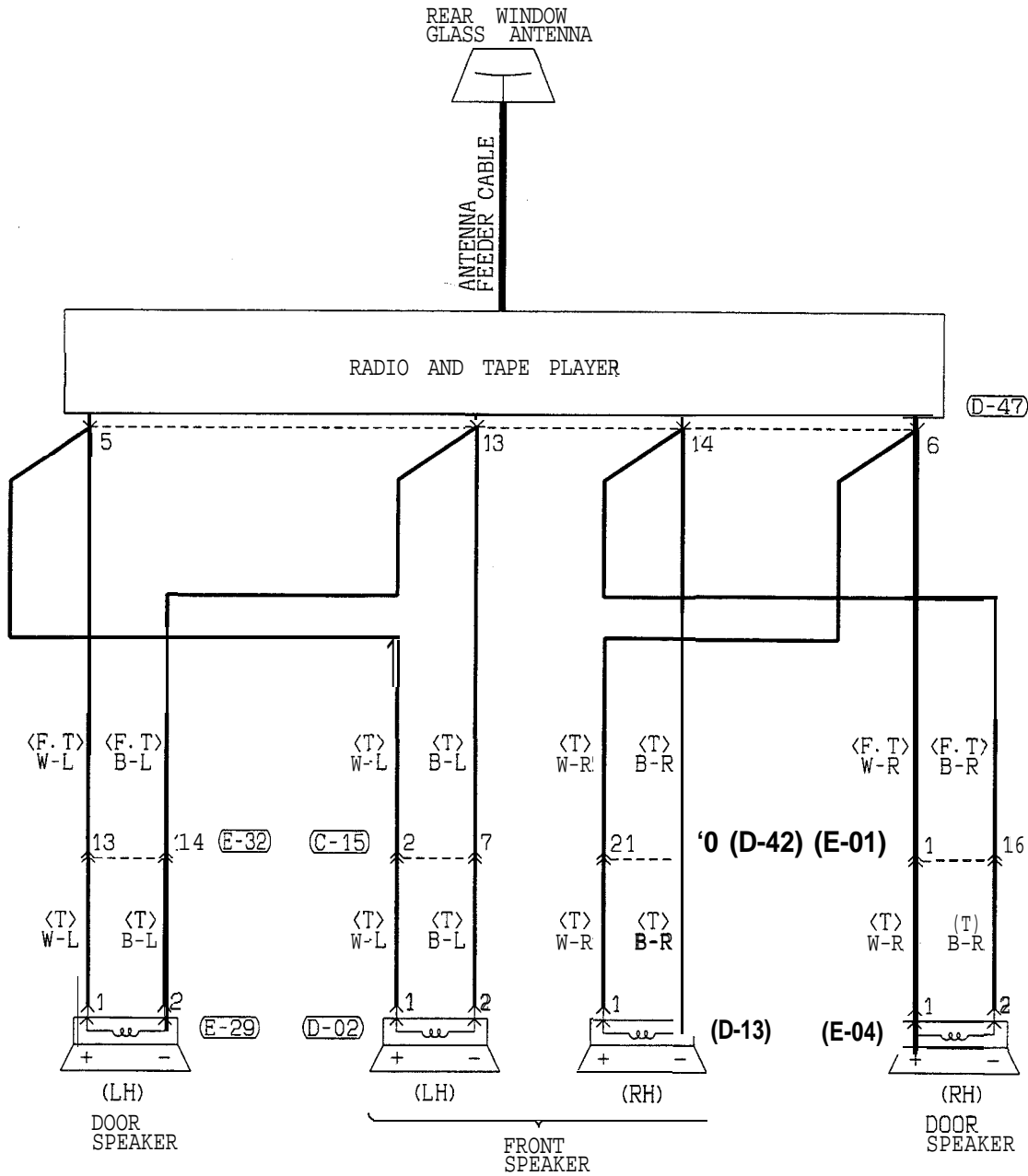

---

NOTES



CIRCUIT DIAGRAM

<Hatchback (From 1995 models-Radio and Tape Player with Amplifier)>

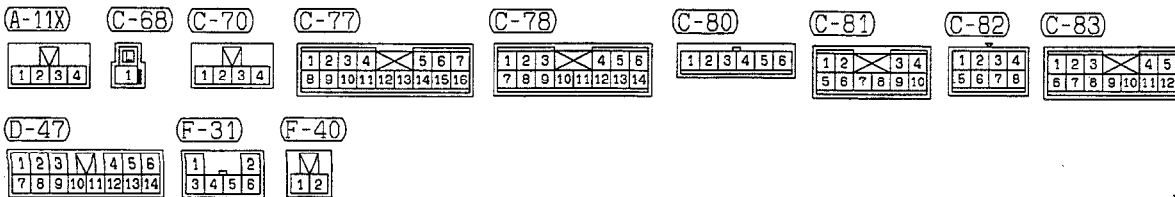
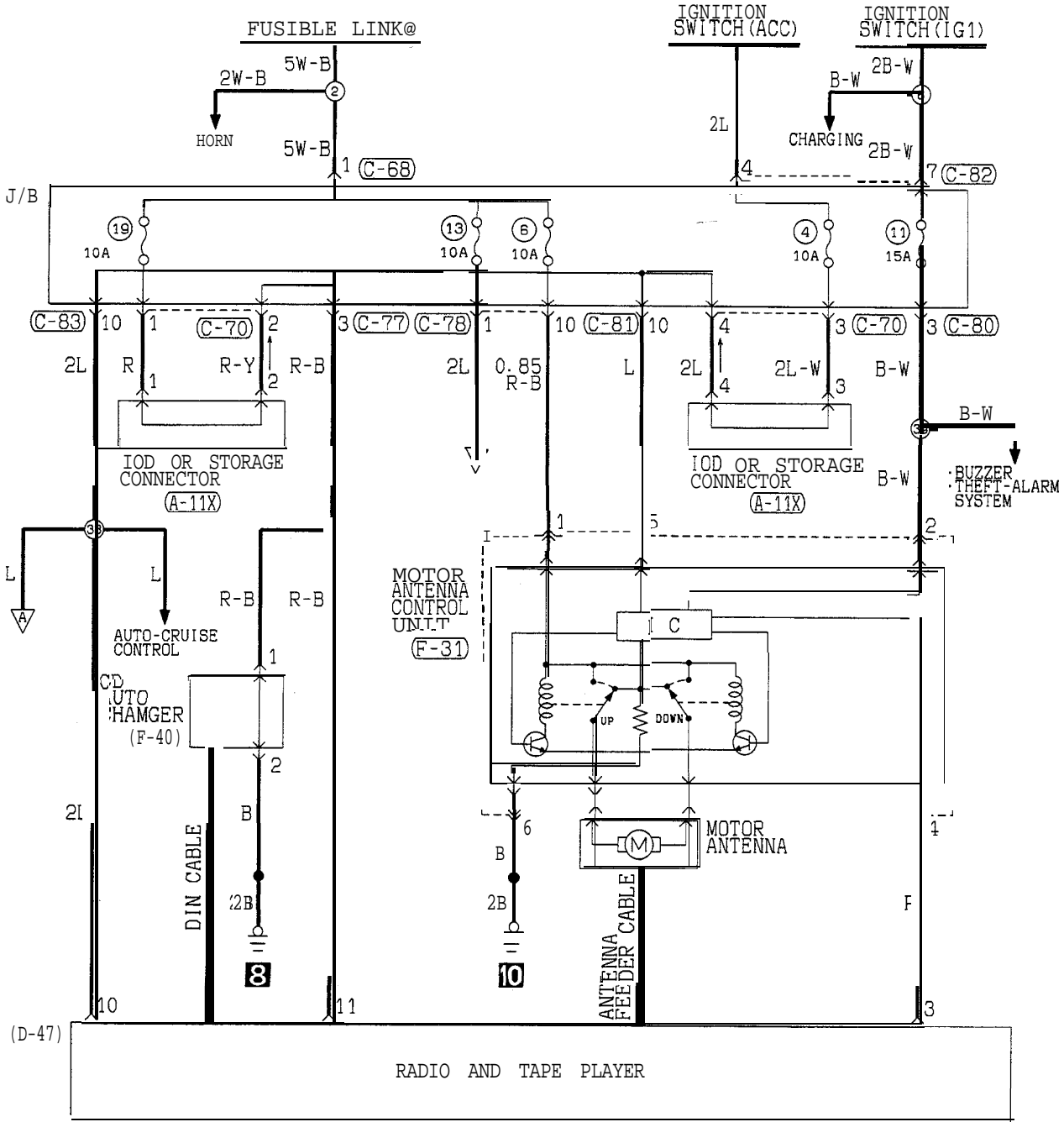

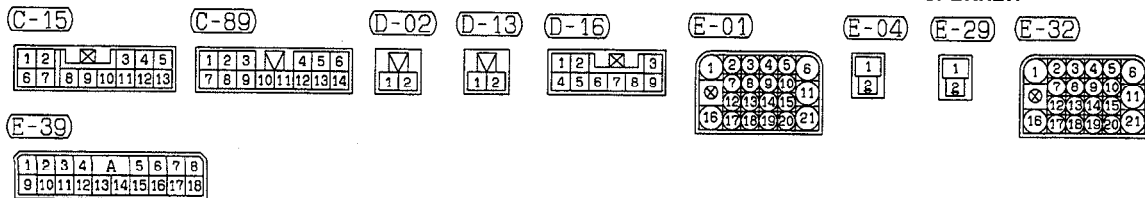
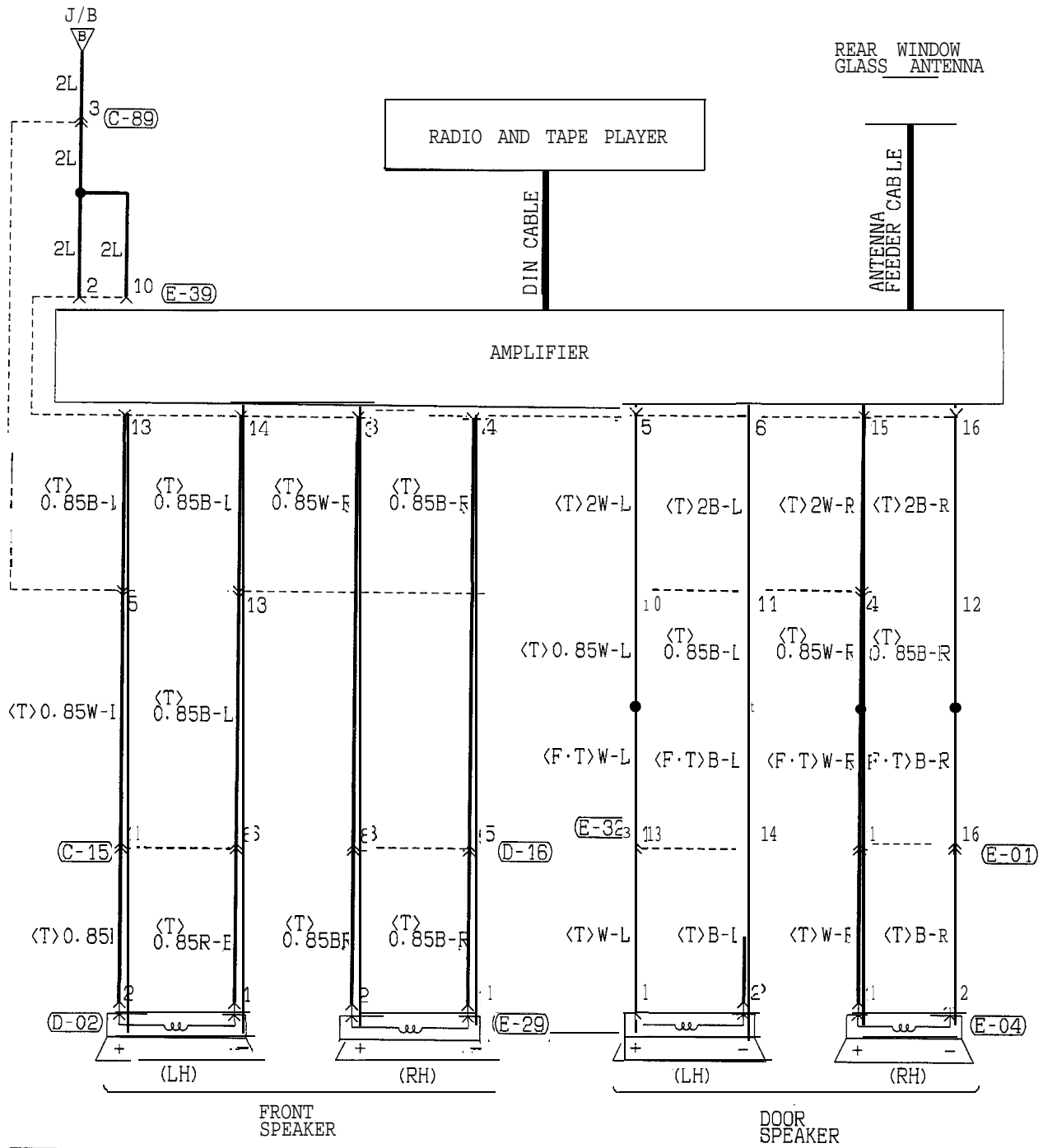

TSB Revision

CIRCUIT DIAGRAM <Hatchback (From 1995 models-Radio and Tape Player with Amplifier)>  
(CONTINUED)

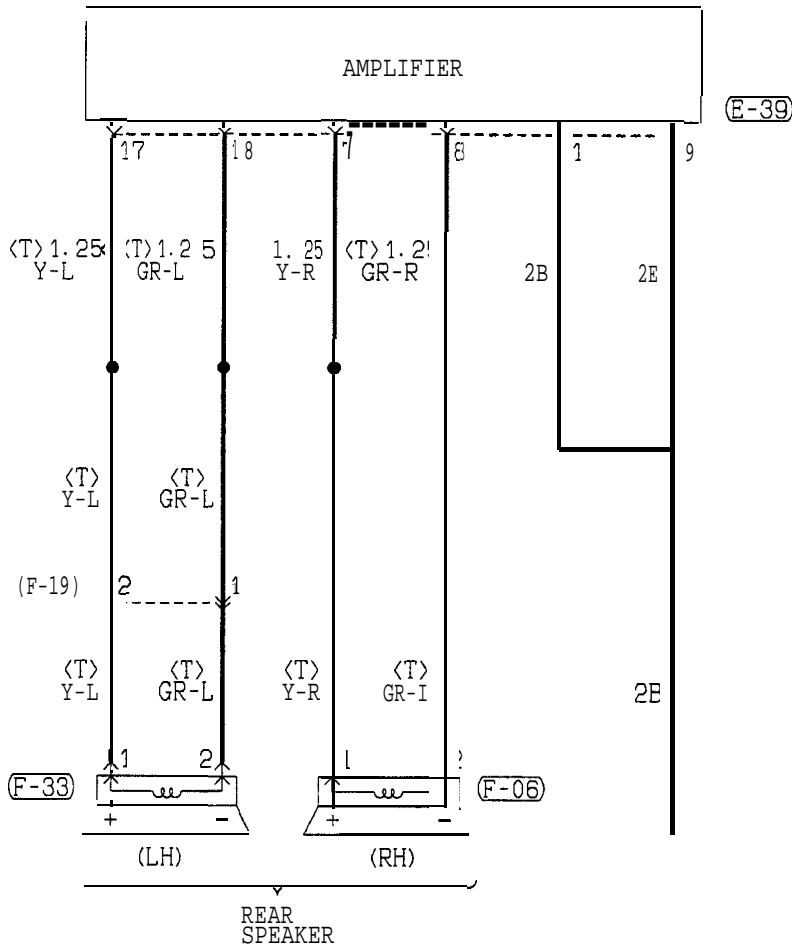

E-39

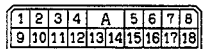

F-06



F-19

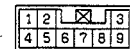

F-33



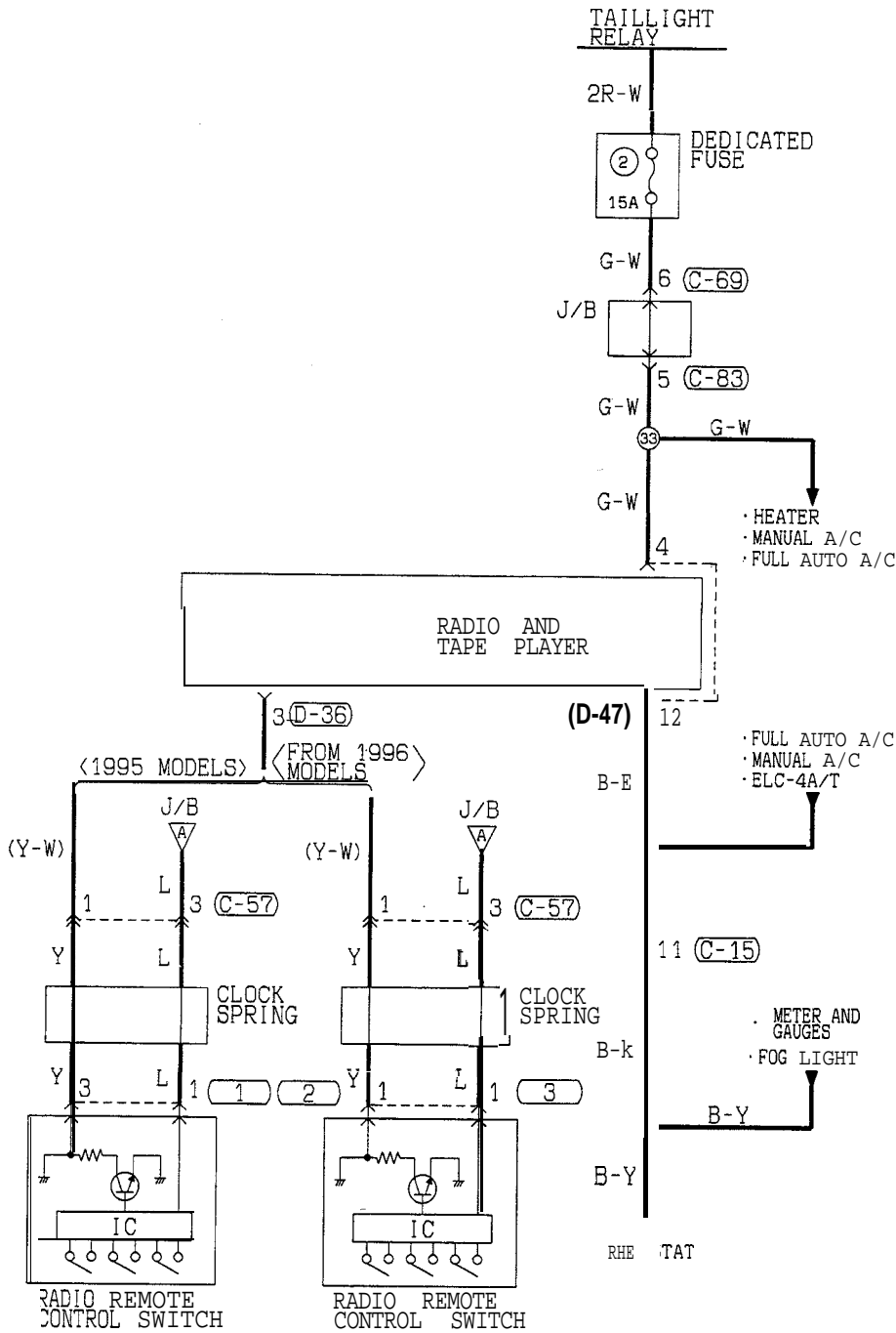

(C-15)

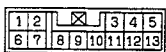

(C-57)



(C-69)



(C-83)

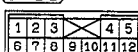

(D-36)

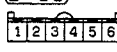

(D-47)

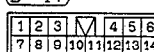

(1)

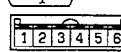

(2)



(3)



CIRCUIT DIAGRAM

<Convertible (1995 models-Radio and Tape Player with Amplifier)>

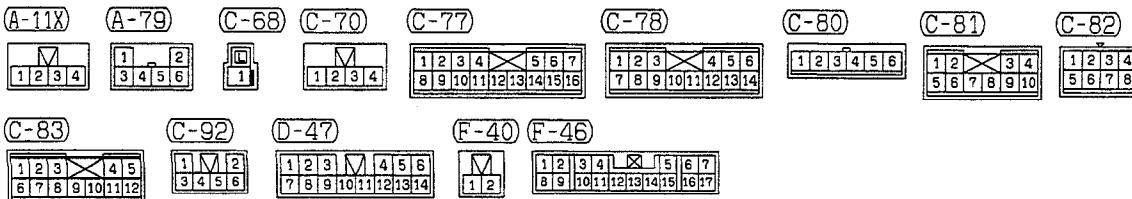
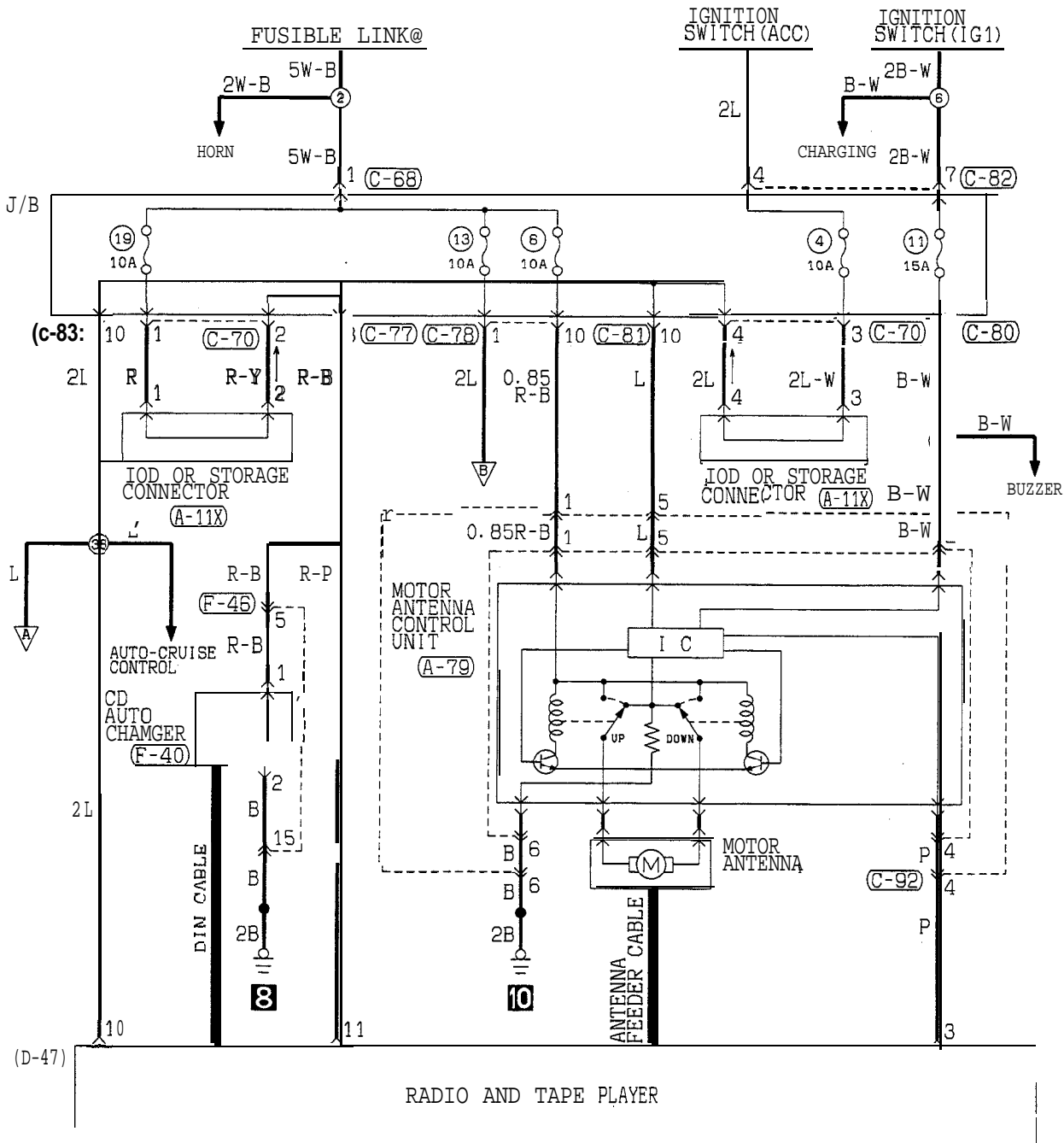

TSB Revision

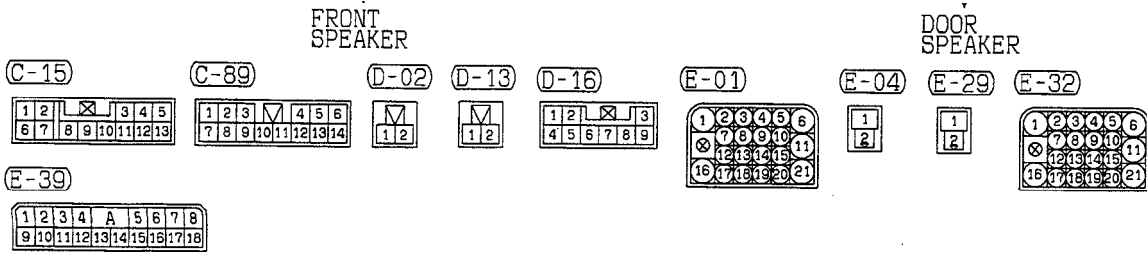
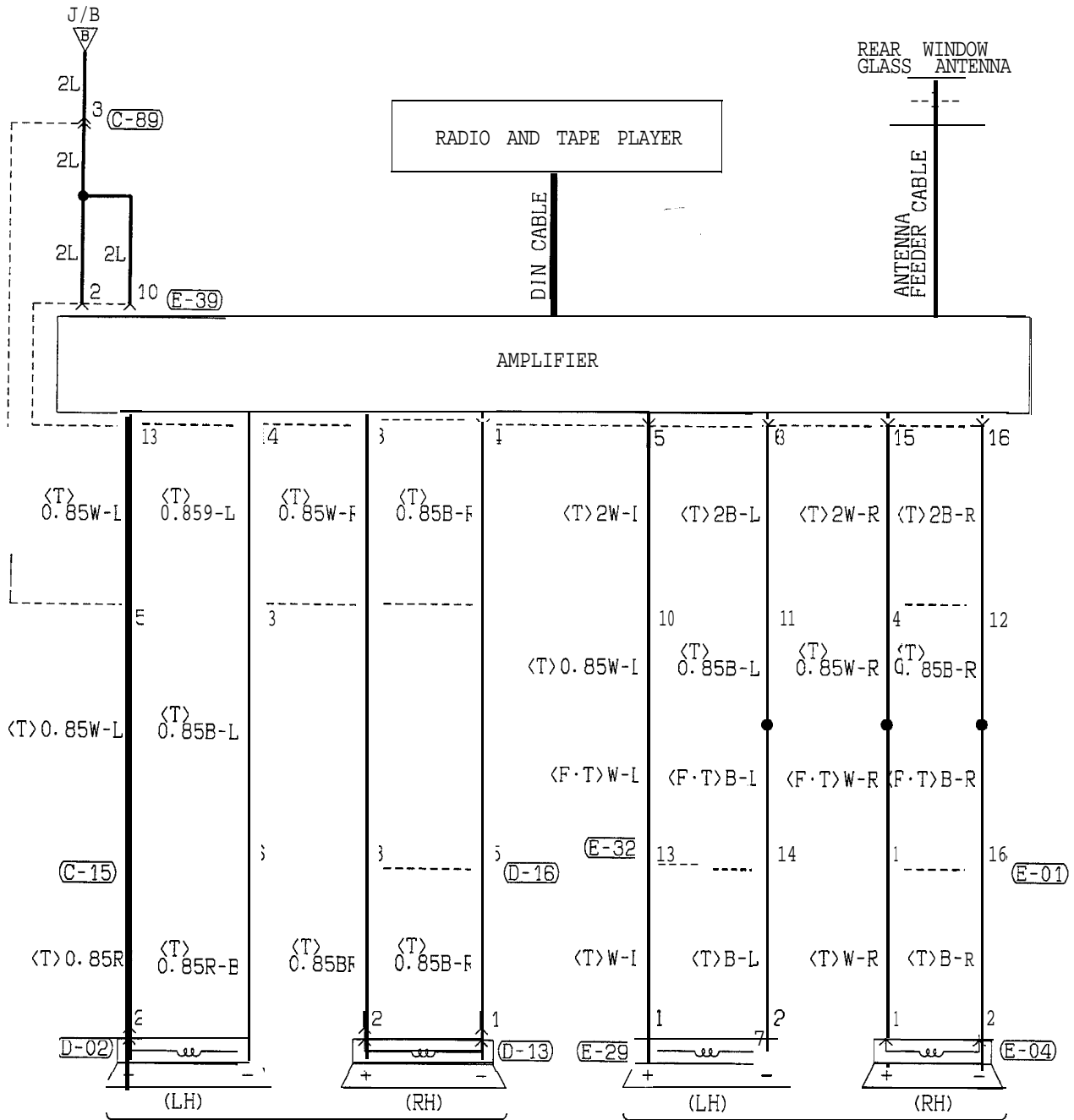

TSB Revision

CIRCUIT DIAGRAM <Convertible (1995 models-Radio and Tape Player with Amplifier)>  
(CONTINUED)

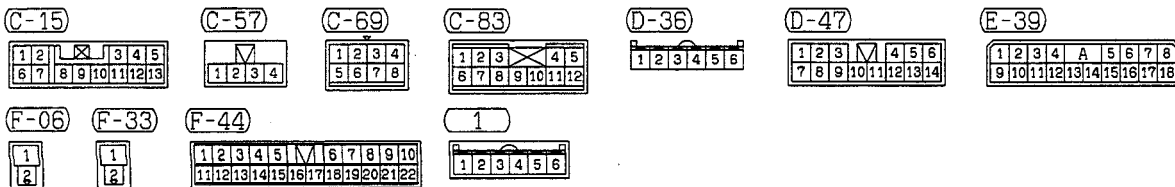
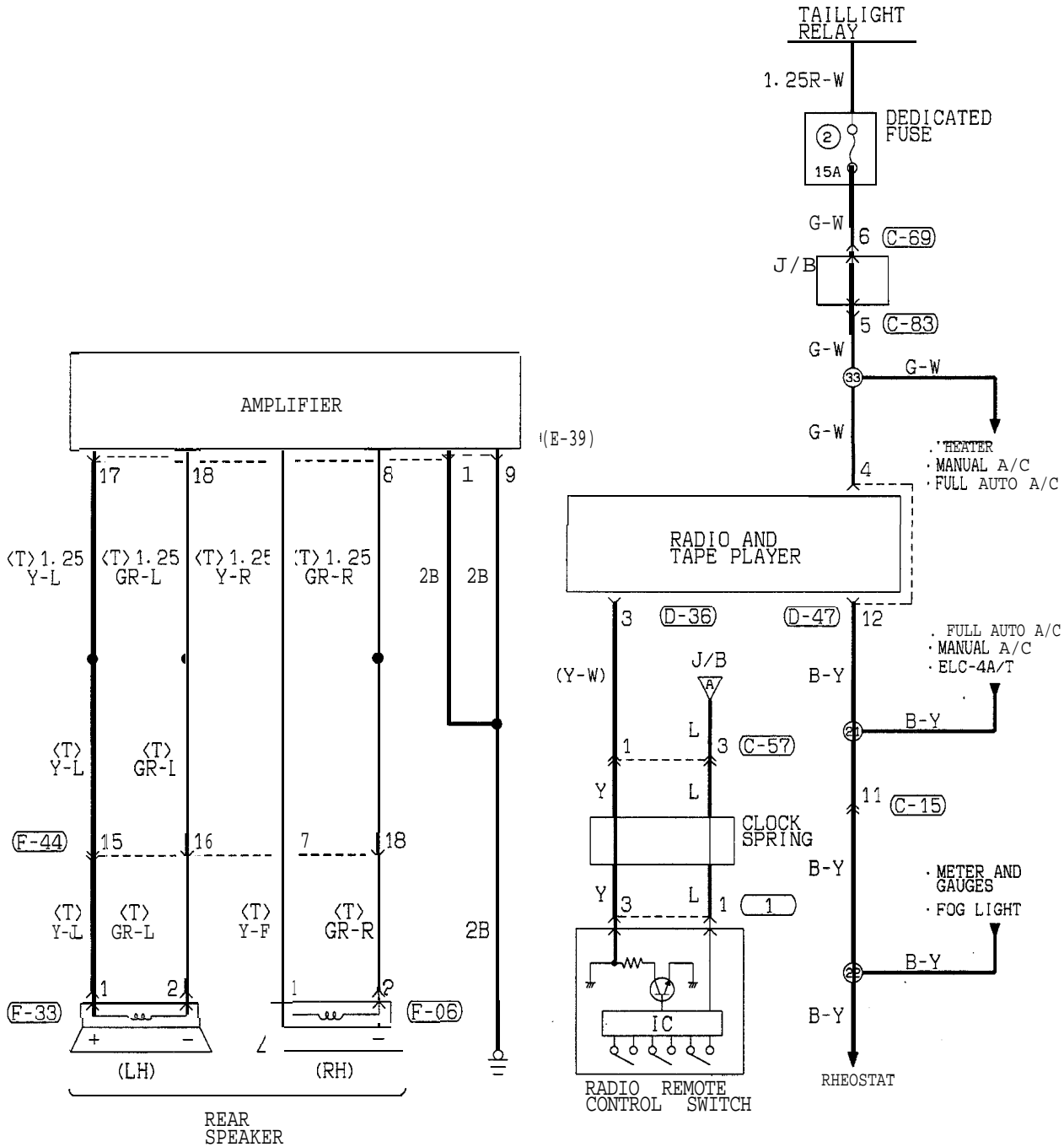

---

NOTES



CIRCUIT DIAGRAM

<Convertible (1995 models-Radio and Tape Player without Amplifier)>

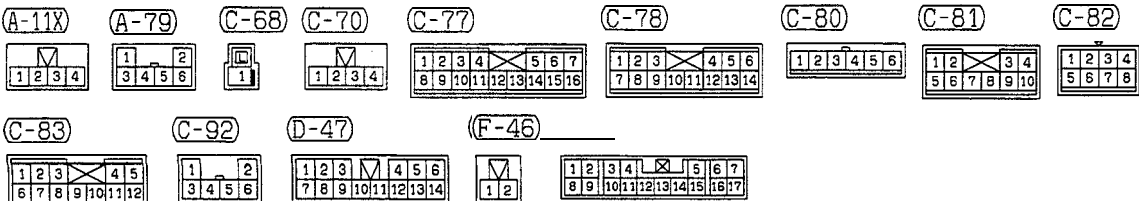
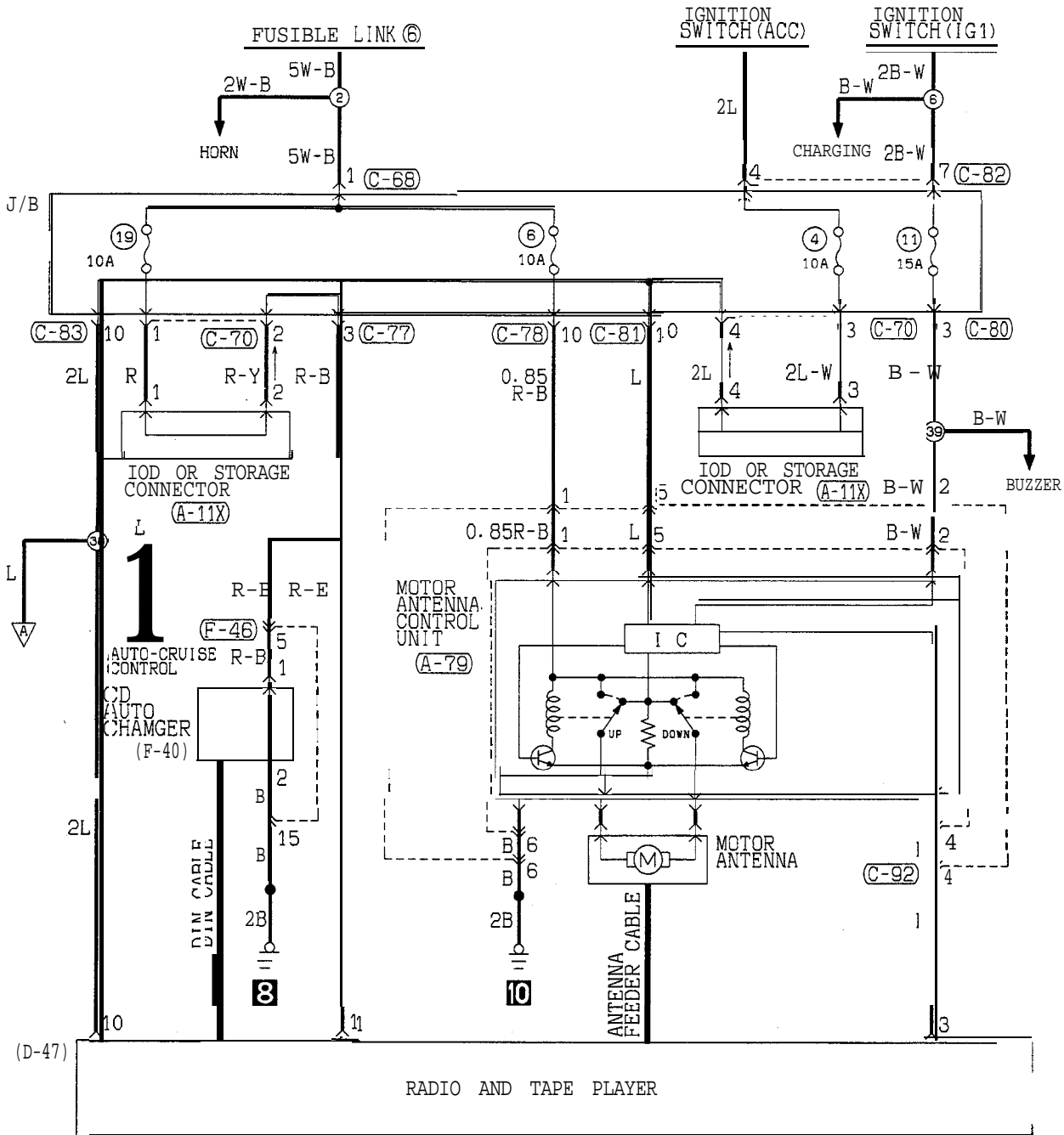

HR14M06AA

TSB Revision

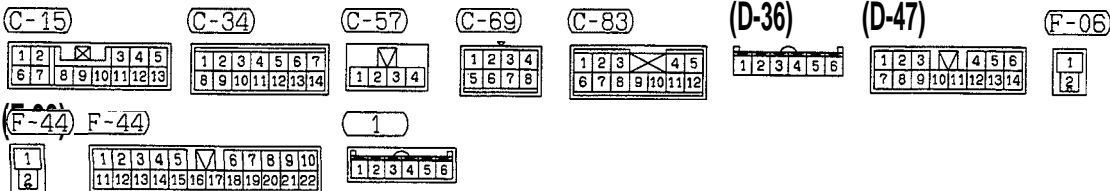
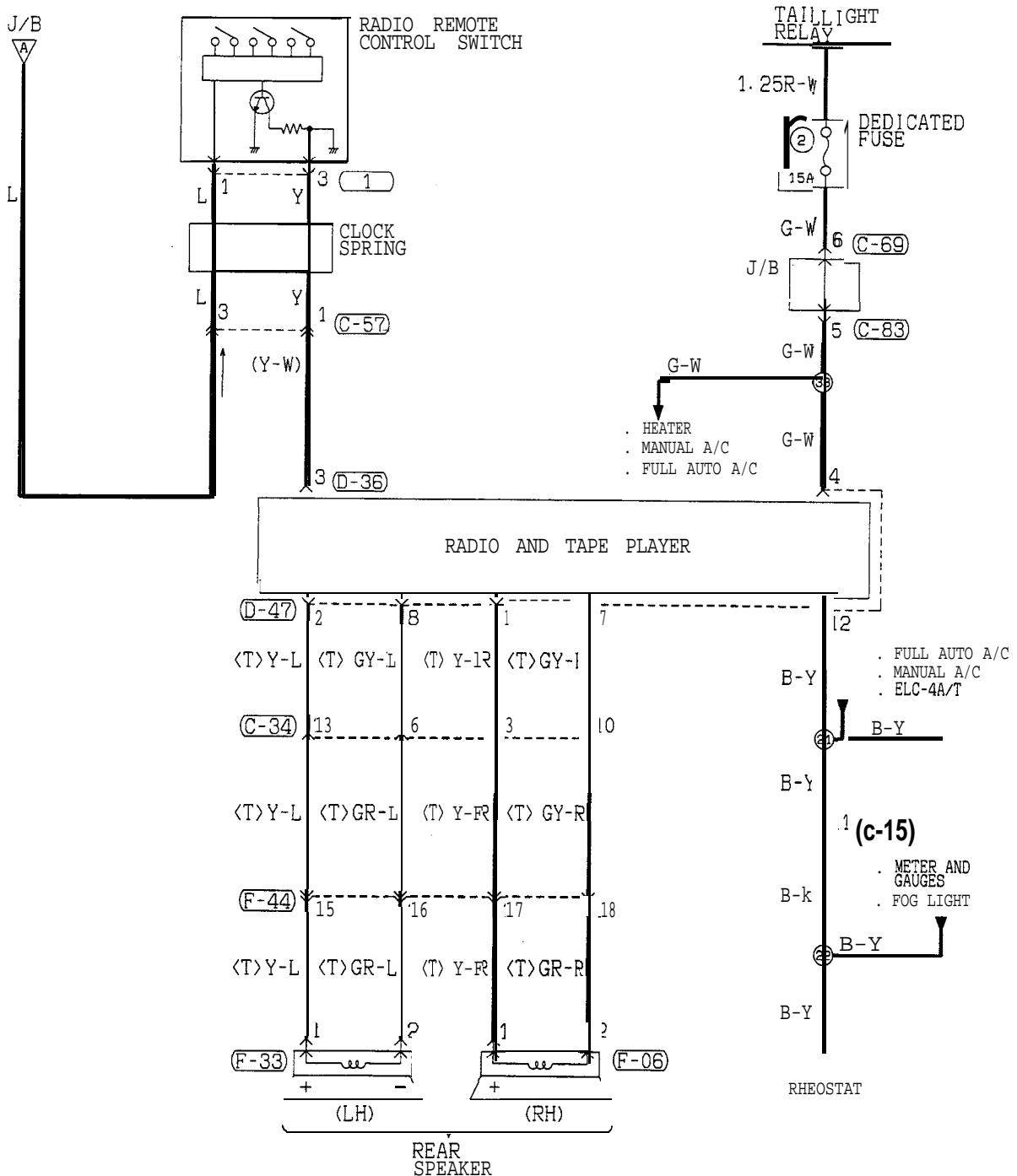

HR14M06AB

CIRCUIT DIAGRAM <Convertible (1995 models-Radio and Tape Player without Amplifier)>  
(CONTINUED)

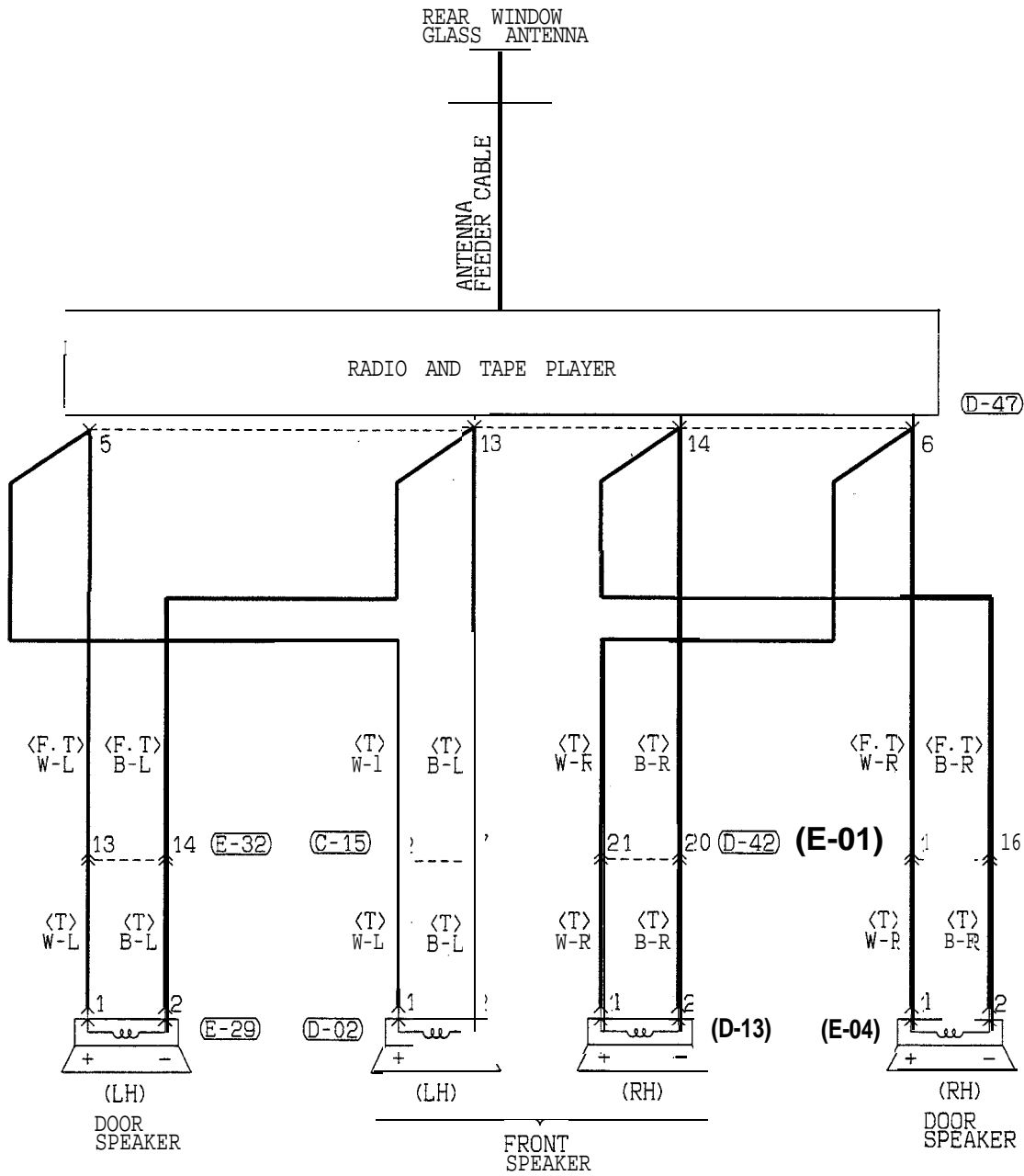

C-15

1	2	3	4	5
6	7	8	9	10
11	12	13		

D-02

1
2

D-13

1
2

D-42

1	2	3	4	5	M	6	7	8	9	10	
11	12	13	14	15	16	17	18	19	20	21	22

D-47

1	2	3	M	4	5	6	
7	8	9	10	11	12	13	14

E-01

1	2	3	4	5	6
7	8	9	10	11	12
13	14	15	16	17	18
19	20	21			

E-04

1
2

E-29

1
2

E-32

1	2	3	4	5	6
7	8	9	10	11	12
13	14	15	16	17	18
19	20	21			

---

NOTES

CIRCUIT DIAGRAM  
 <Convertible (From 1996 models)>

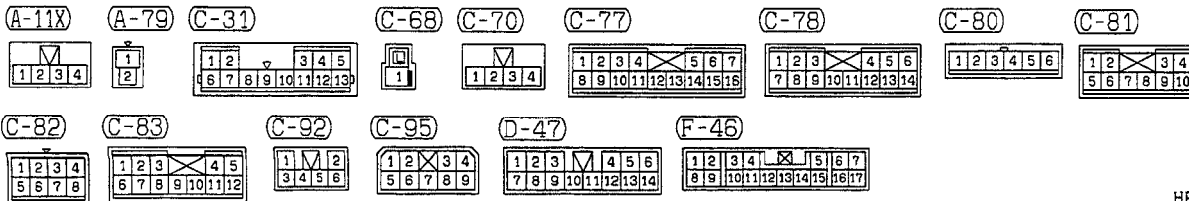
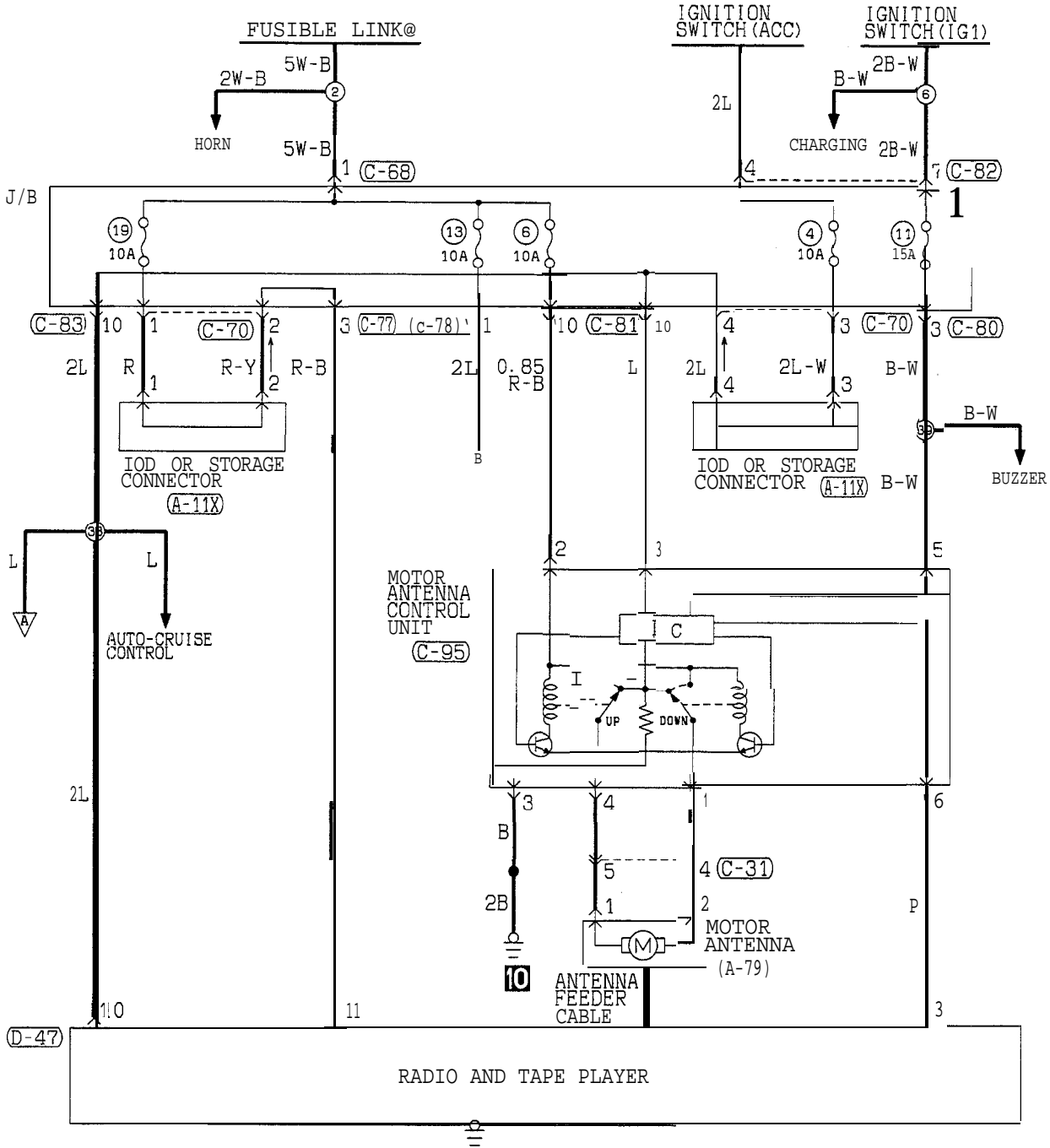

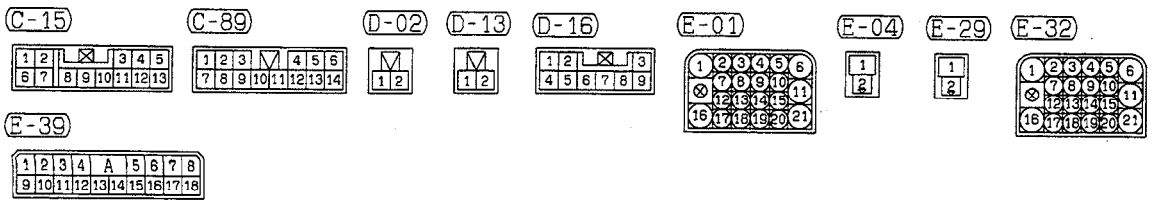
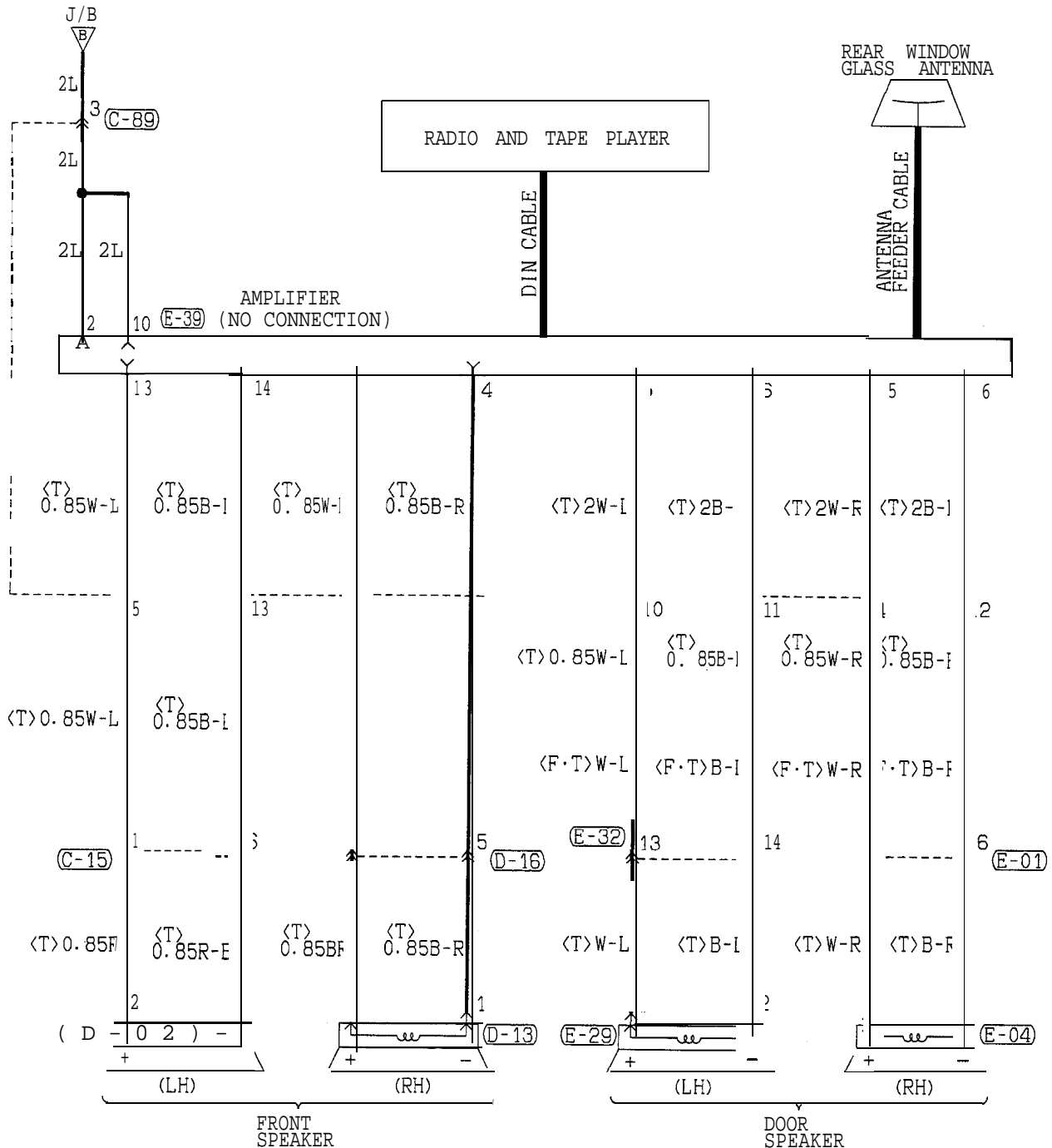

TSB Revision

CIRCUIT DIAGRAM <Convertible (From 1996 models)> (CONTINUED)

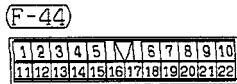
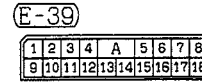
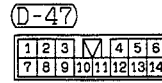
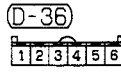
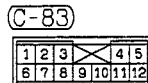
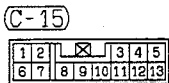
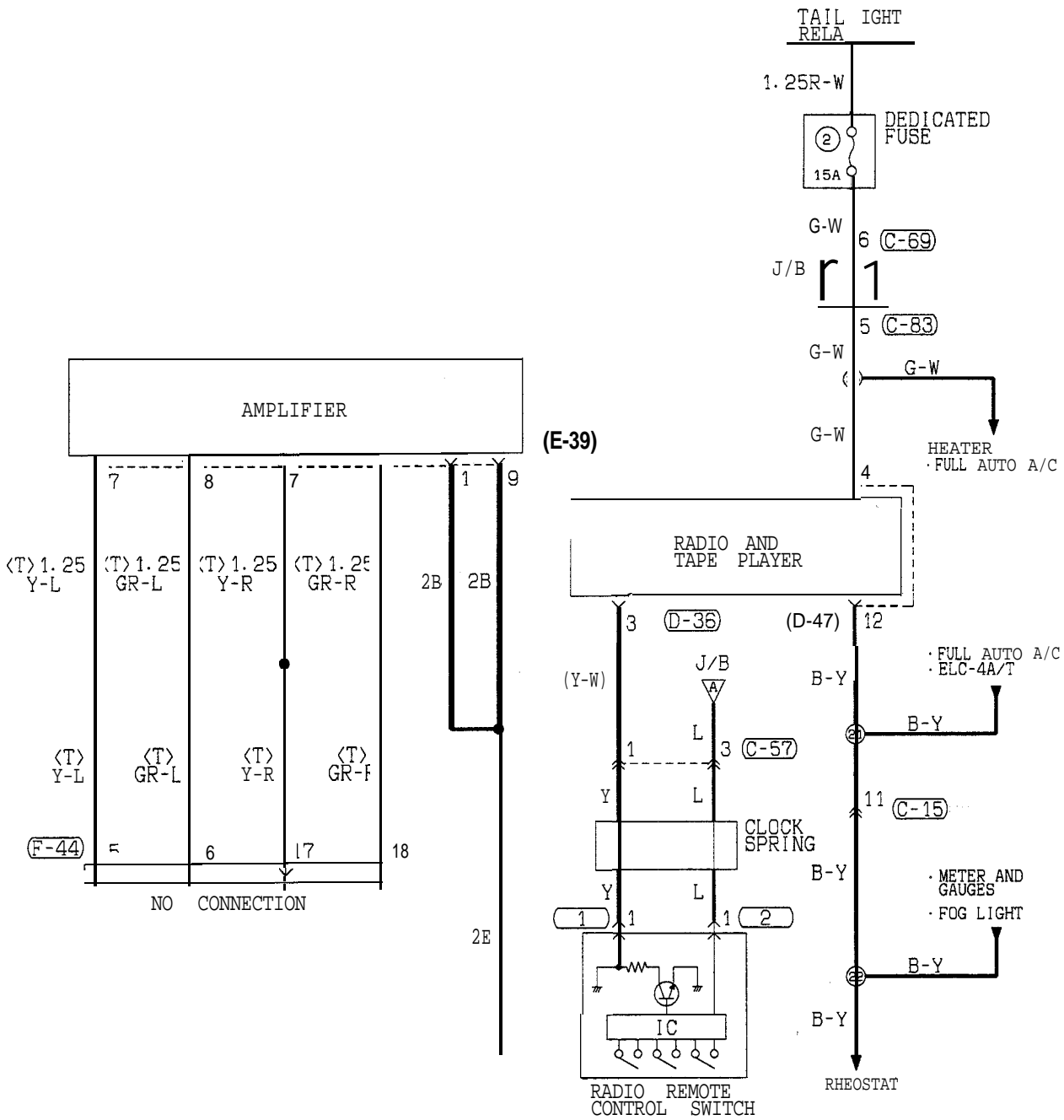

HR14M07BA

COMPONENT LOCATION

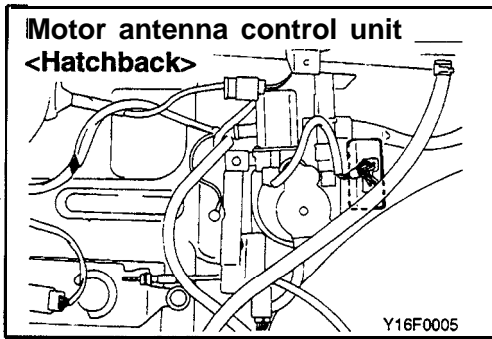



**RADIO AND TAPE PLAYER WITH ANTI-THEFT SYSTEM**

- When power supply is reconnected after set has been removed from vehicle (after BATT line of set has been disconnected for more than one hour), what can be effectively performed is only supply of power made by POWER button operation. (If power supply is connected within an hour, operating state before disconnection of power supply is resumed.)

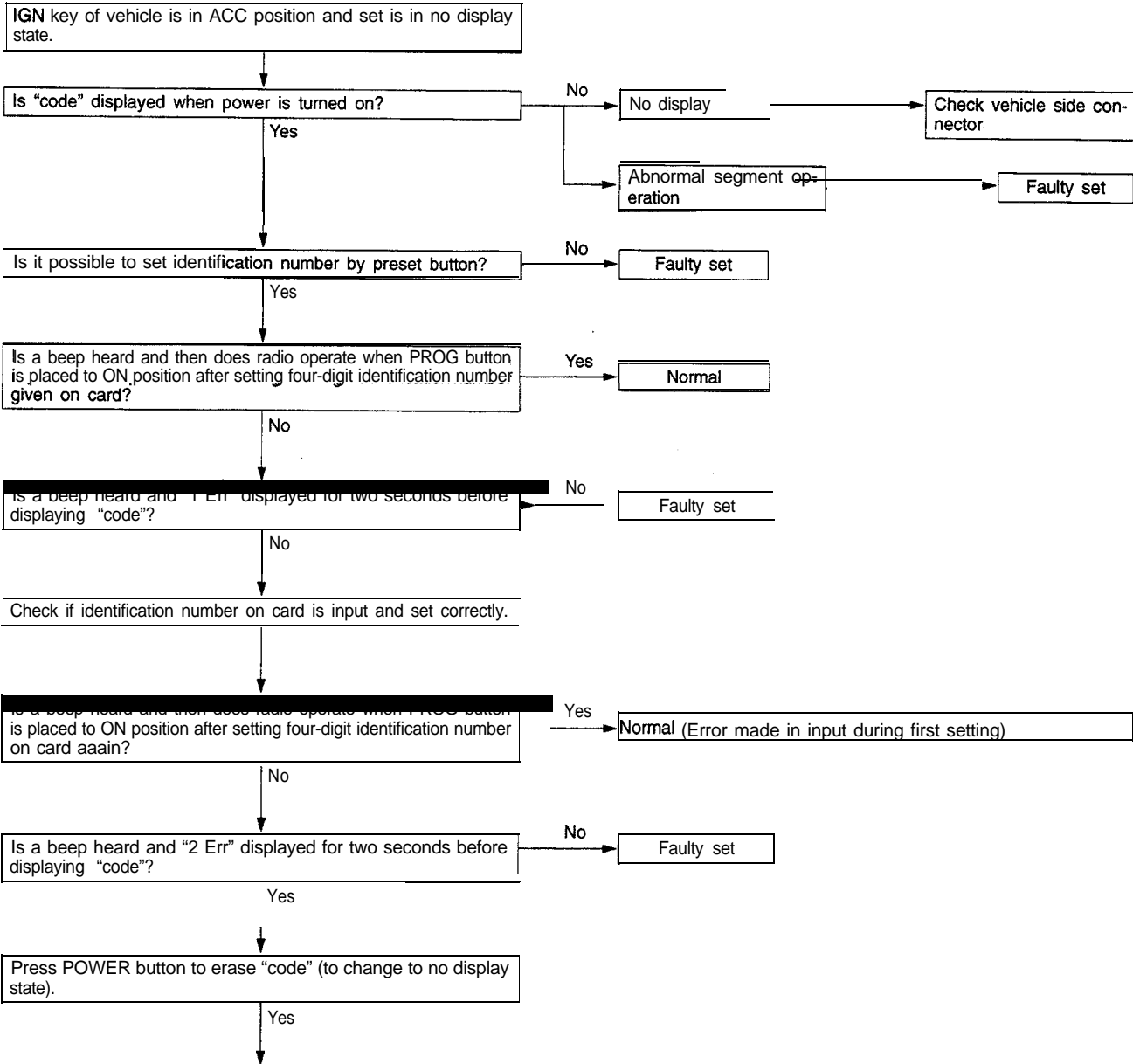

Continued to next page.

Continued from previous Page

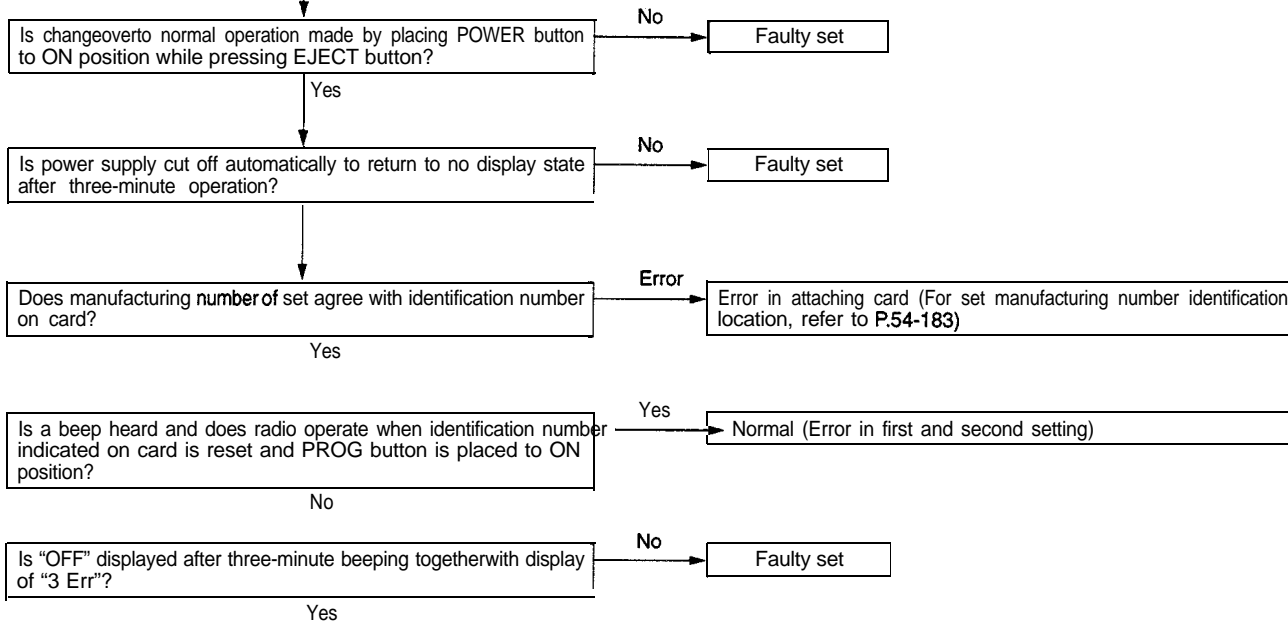

- In this state, only POWER button operation is accepted ("OFF" is displayed) and no other button operation can be made effectively.
- In the "OFF" state, continuation of the BATT, ACC line ON state for more than one hour will allow identification number checking operation again and placing the POWER button to ON position will display "code" and wait for input.

## TROUBLESHOOTING CHART

Item	problem symptom	Relevant chart
Noise	Noise appears at certain places when traveling (AM).	A-1
	Noise appears at certain places when traveling (FM).	A-2
	Mixed with noise, only at night (AM).	A-3
	Broadcasts can be heard but both AM and FM have a lot of noise.	A-4
	There is more noise either on AM or on FM.	A-5
	There is noise when starting the engine.	A-6
	Some noise appears when there is vibration or shocks during traveling.	A-7
	Noise sometimes appears on FM during traveling.	A-8
	Ever-present noise.	A-9
Radio	When switch is set to ON, no power is available.	B-1
	No sound from one speaker.	B-2
	There is noise but no reception for both AM and FM or no sound from AM, or no sound from FM.	B-3
	Insufficient sensitivity.	B-4
	Distortion on AM or on both AM and FM.	B-5
	Distortion on FM only.	B-6
	Too few automatic select stations.	B-7
	Insufficient memory (preset stations are erased).	B-8
Cassette player	Cassette tape will not be inserted.	C-1
	No sound.	C-2
	No sound from one speaker.	C-3
	Sound quality is poor, or sound is weak.	C-4
	Cassette tape will not be ejected.	C-5
	Uneven revolution. Tape speed is fast or slow.	C-6
	Automatic search does not work.	C-7
	Faulty auto reverse.	C-8
	Tape gets caught in mechanism.	C-9
CD player	CD will not be accepted.	D-1
	No sound.	D-2
	CD sound skips.	D-3
	Sound quality is poor.	D-4
	CD will not be ejected.	D-5
	No sound from one speaker.	D-6
Motor antenna	Motor antenna won't extend or retract.	E-1
	Motor antenna extends and retracts but does not receive.	E-2

CHART

A. NOISE

**A-I Noise appears at certain places when traveling (AM).**

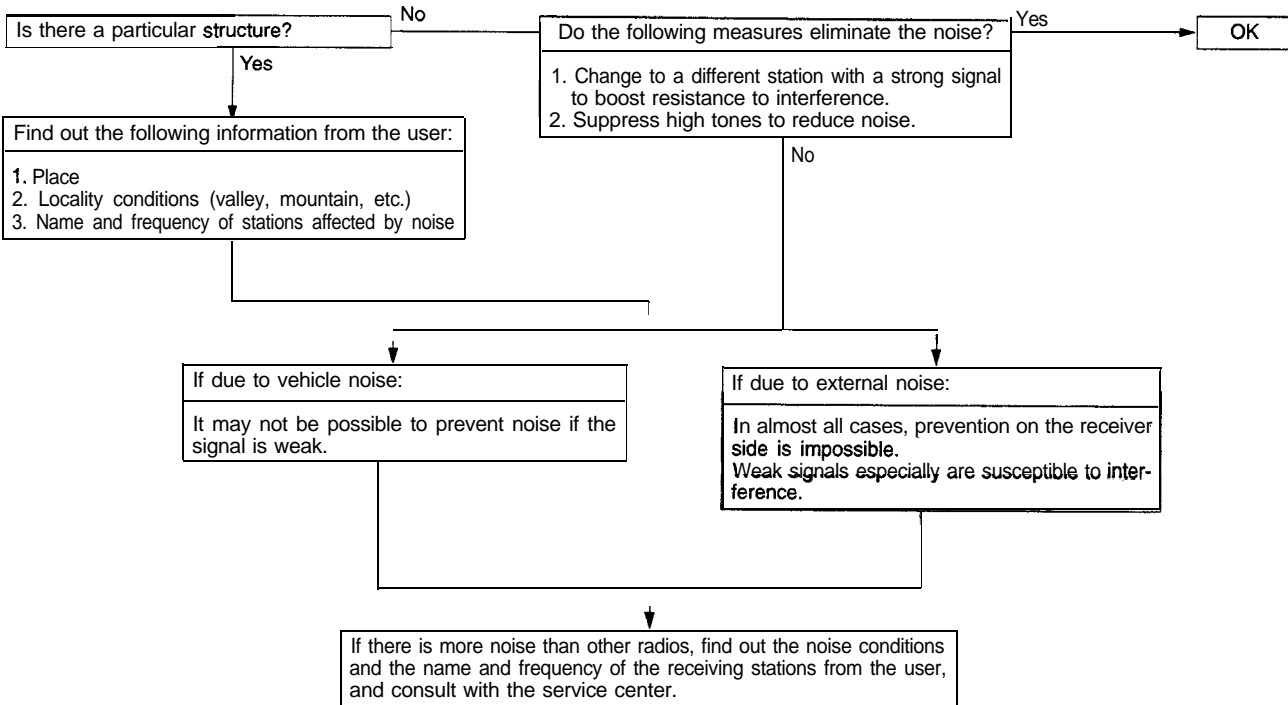

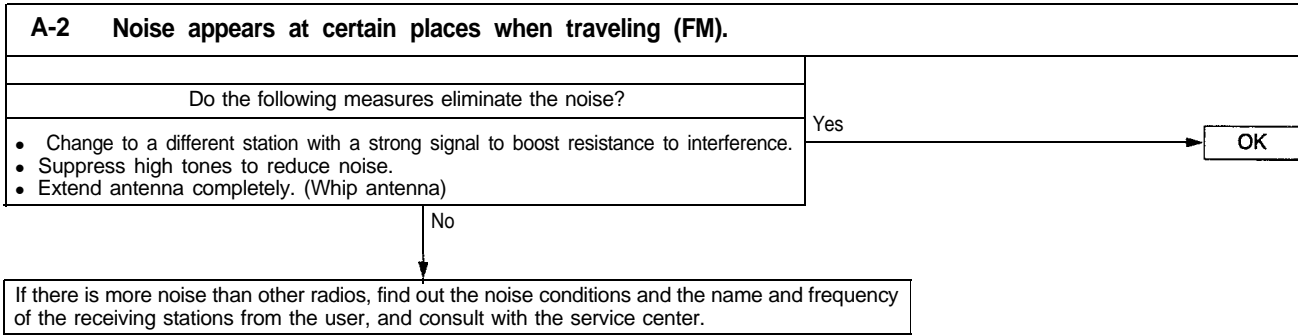

**NOTE**

About FM waves:

FM waves have the same properties as light, and can be deflected and blocked. Wave reception is not possible in the shadow of obstructions such as buildings or mountains.

1. The signal becomes weak as the distance from the station's transmission antenna increases. Although this may vary according to the signal strength of the transmitting station and intervening geographical formations or buildings, the area of good reception is approx. 20–25 km (12–16 miles) for stereo reception, and 30–40 km (19–25 miles) for monaural reception.
2. The signal becomes weak when an area of shadow from the transmitting antenna (places where there are obstructions such as mountains

or buildings between the antenna and the car), and noise will appear. <This is called first fading, and gives a steady buzzing noise.>

3. If a direct signal hits the antenna at the same time as a signal reflected by obstructions such as mountains or buildings, interference of the two signals will generate noise. During traveling, noise will appear each time the vehicle's antenna passes through this kind of obstructed area. The strength and interval of the noise varies according to the signal strength and the conditions of deflection. <This is called multipath noise, and is a repetitious buzzing.>
4. Since FM stereo transmission and reception has a weaker field than monaural, it is often accompanied by a hissing noise.

**FM Broadcast Good Reception Areas**

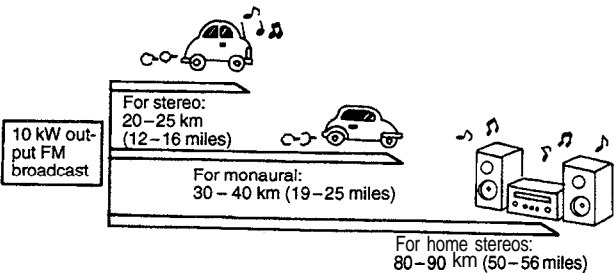

Z16A0663

**FM Signal Characteristics and Signal Interference**

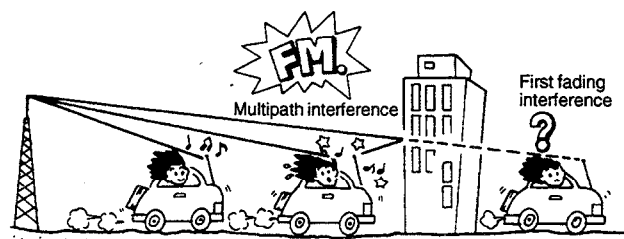

Z16A0664  
00002401

**TSB Revision**

**A-3 Mixed with noise, only at night (AM).**

The following factors can be considered as possible causes of noise appearing at night.

1. Factors due to signal conditions: Due to the fact that long-distance signals are more easily received at night, even stations that are received without problem during the day may experience interference in a general worsening of reception conditions. The weaker a station is the more susceptible it is to interference, and a change

to a different station or the appearance of a beating sound\* may occur.

Beat sound\*: Two signals close in frequency interfere with each other, creating a repetitious high-pitched sound. This sound is generated not only by sound signals but by electrical waves as well.

2. Factors due to vehicle noise: Generator noise may be a cause.

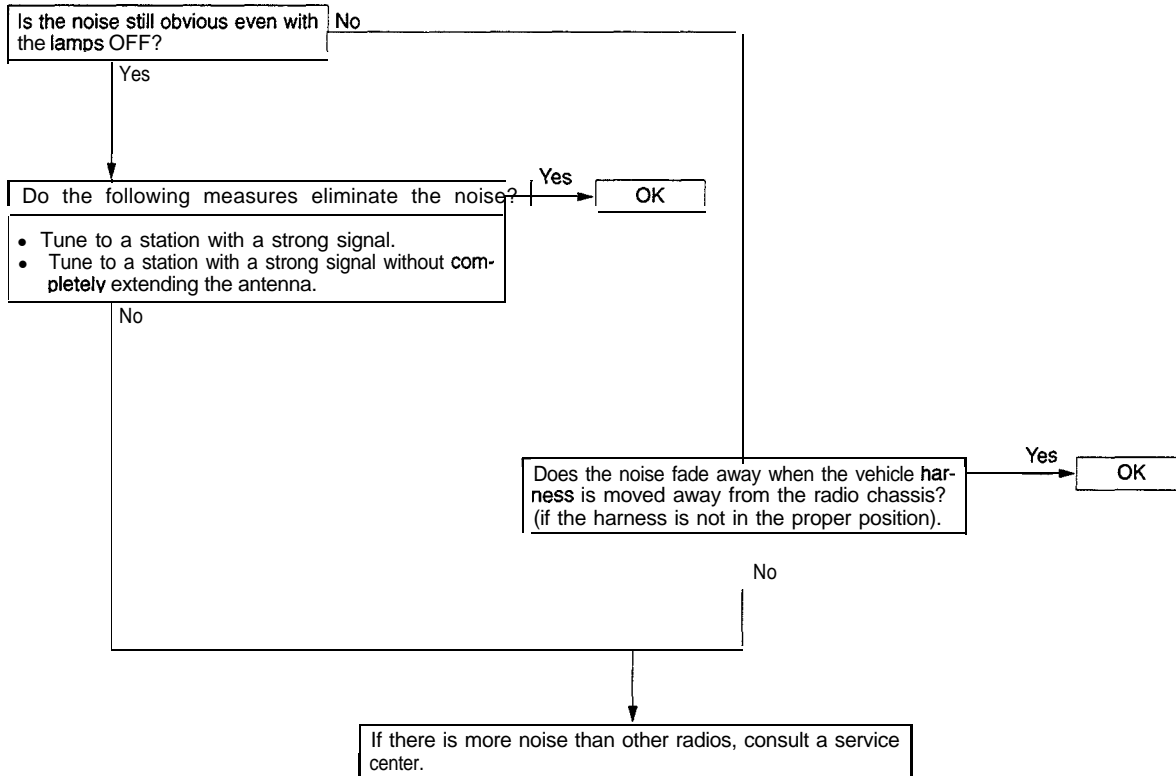

A-4 Broadcasts can be heard but both AM and FM have a lot of noise.

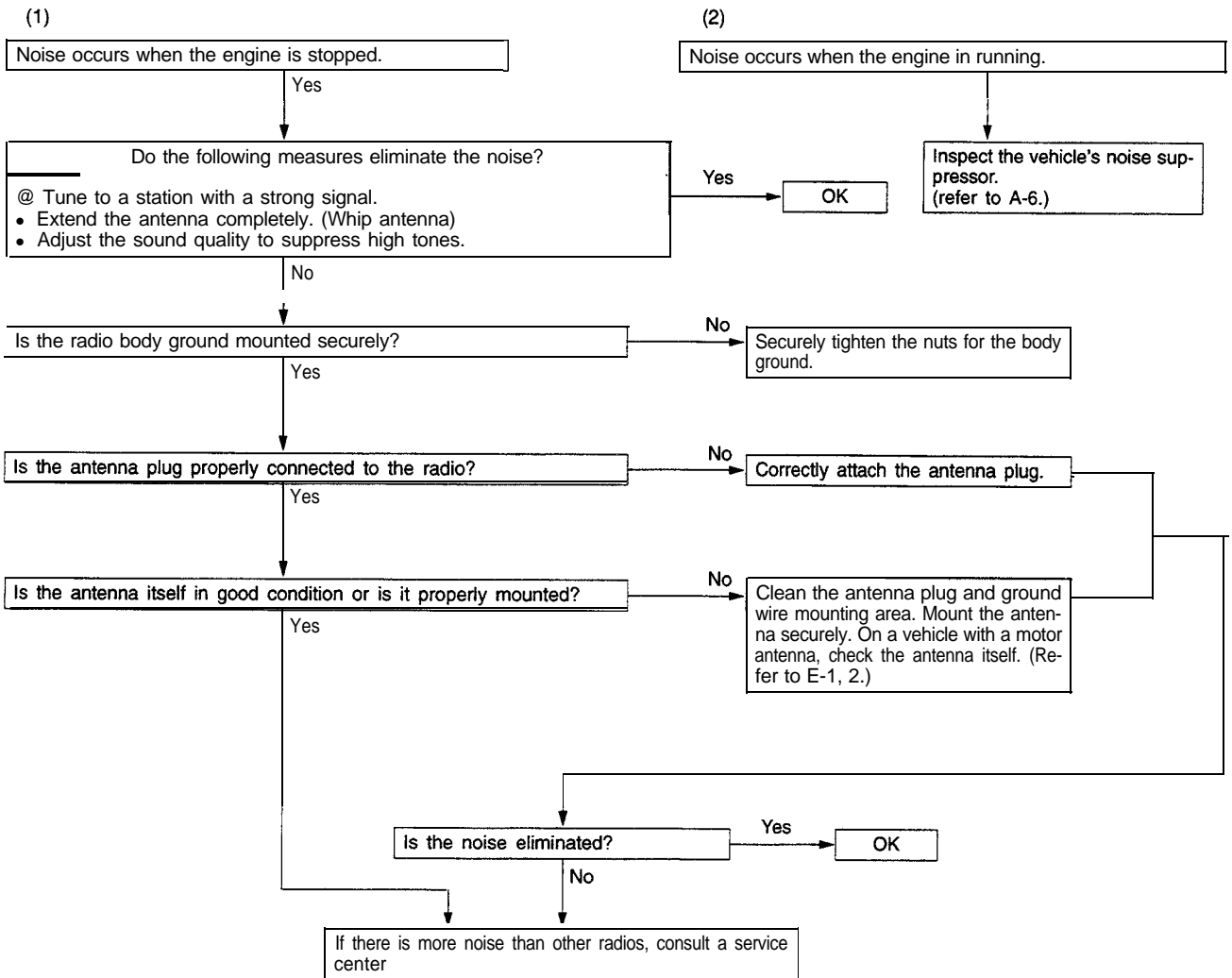

**NOTE**  
 About noise encountered during FM reception only. Due to differences in FM and AM systems, FM is not as susceptible as AM to interference from engines, power lines, lightning, etc. On the other hand, there are cases due to the characteristics of FM waves of noise or distortion generated by typical noise interference (first fading and multipath). (Refer to A-2.)  
 <Noise (hissing) occurs in weak signal areas such as mountainous regions, but this is not due to a problem with the radio.>

**A-5 There is more noise either on AM or on FM.**

1. There is much noise only on AM  
 Due to differences in AM and FM systems, AM is more susceptible to noise interference.

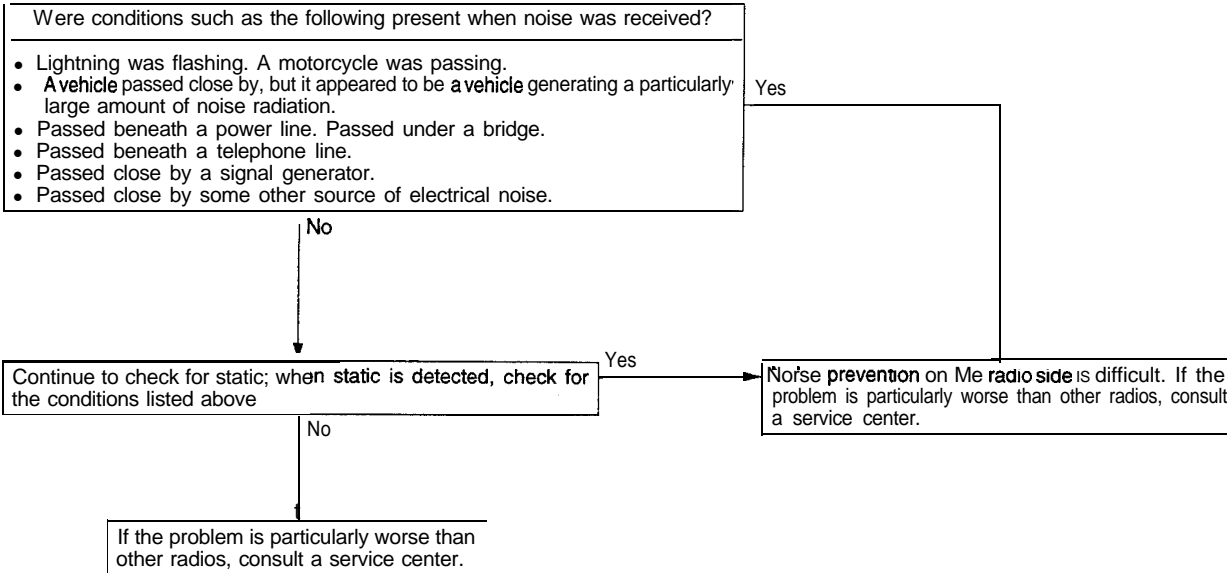

2. There is much noise only on FM  
 Due to differences in FM and AM systems, FM is not as susceptible as AM to interference from engines, power lines, lightning, etc. On the other hand, there are cases due to the characteristics of FM waves of noise or distortion generated

by typical noise interference (first fading and multipath). (Refer to A-2) <Noise (hissing) occurs in weak signal areas such as mountainous regions, but this is not due to a problem with the radio.>



## A-6 There is noise when starting the engine.

Noise type Sounds are in parentheses ( ).	Conditions	Cause	Parts to be inspected or remedy	Location of parts (next page)
AM, FM: Ignition noise (Popping, Snapping, Cracking, Buzzing)	<ul style="list-style-type: none"> <li>Increasing the engine speed causing the popping sound to speed up, and volume decreases.</li> <li>Disappears when the ignition switch is turned to ACC.</li> </ul>	<ul style="list-style-type: none"> <li>Mainly due to the spark plugs.</li> <li>Due to the engine noise.</li> </ul>	Noise condenser	1
			Ground cable	2, 3
Other electrical components	—	Noise may appear as electrical components become older.	Repair or replace electrical components.	
Static electricity (Cracking, Crinkling)	<ul style="list-style-type: none"> <li>Disappears when the vehicle is completely stopped.</li> <li>Severe when the clutch is engaged.</li> <li>Various noises are produced depending on the body part of the vehicle.</li> </ul>	Occurs when parts or wiring move for some reason and contact metal parts of the body.	Return parts or wiring to their proper position.	
		Due to detachment from the body of the front hood, bumpers, exhaust pipe and muffler, suspension, etc.	Ground parts by bonding. Cases where the problem is not eliminated by a single response to one area are common, due to several body parts being imperfectly grounded.	

**Caution**

1. Connecting a high tension cable to the noise filter may destroy the noise filter and should never be done.
2. Check that there is no external noise. Since failure to do this may result in misdiagnosis due to inability to identify the noise source, this operation must be performed.
3. Noise prevention should be performed by suppressing strong sources of noise step by step.

**NOTE**

## 1. Condenser

The condenser does not pass D.C. current, but as the number of waves increases when it passes A.C. current, impedance (resistance

against A.C.) decreases, and current flow is facilitated. A noise suppressing condenser which takes advantage of this property is inserted between the power line for the noise source and the ground. This suppresses noise by grounding the noise component (A.C. or pulse signal) to the body of the vehicle.

## 2. Coil

The coil passes D.C. current, but impedance rises as the number of waves increases relative to the A.C. current. A noise suppressing coil which takes advantage of this property is inserted into the power line for the noise source, and works by preventing the noise component from flowing or radiating out of the line.

NOISE SUPPRESSION PARTS MOUNTING POSITIONS

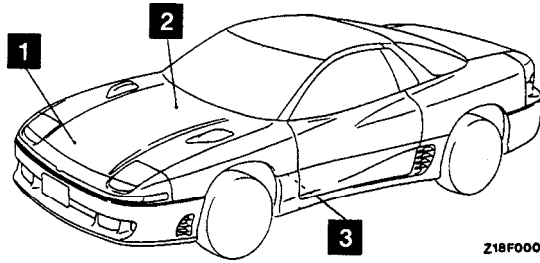

Z16F005

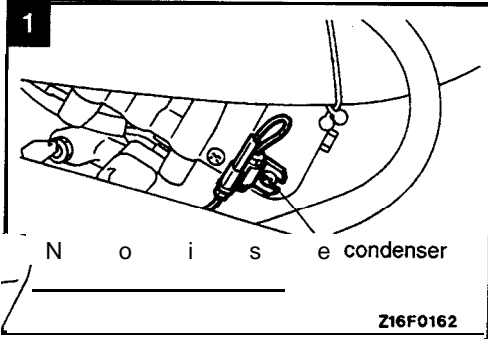

Z16F0162

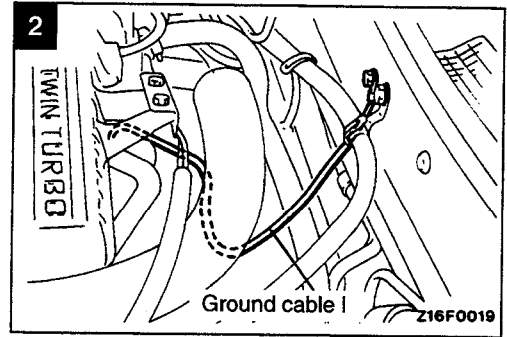

Z16F0019

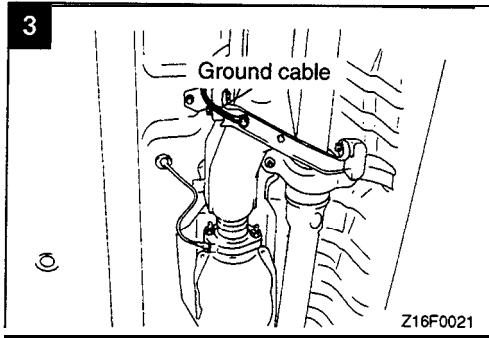

Z16F0021

A-7 Some noise appears when there is vibration or shocks during traveling.

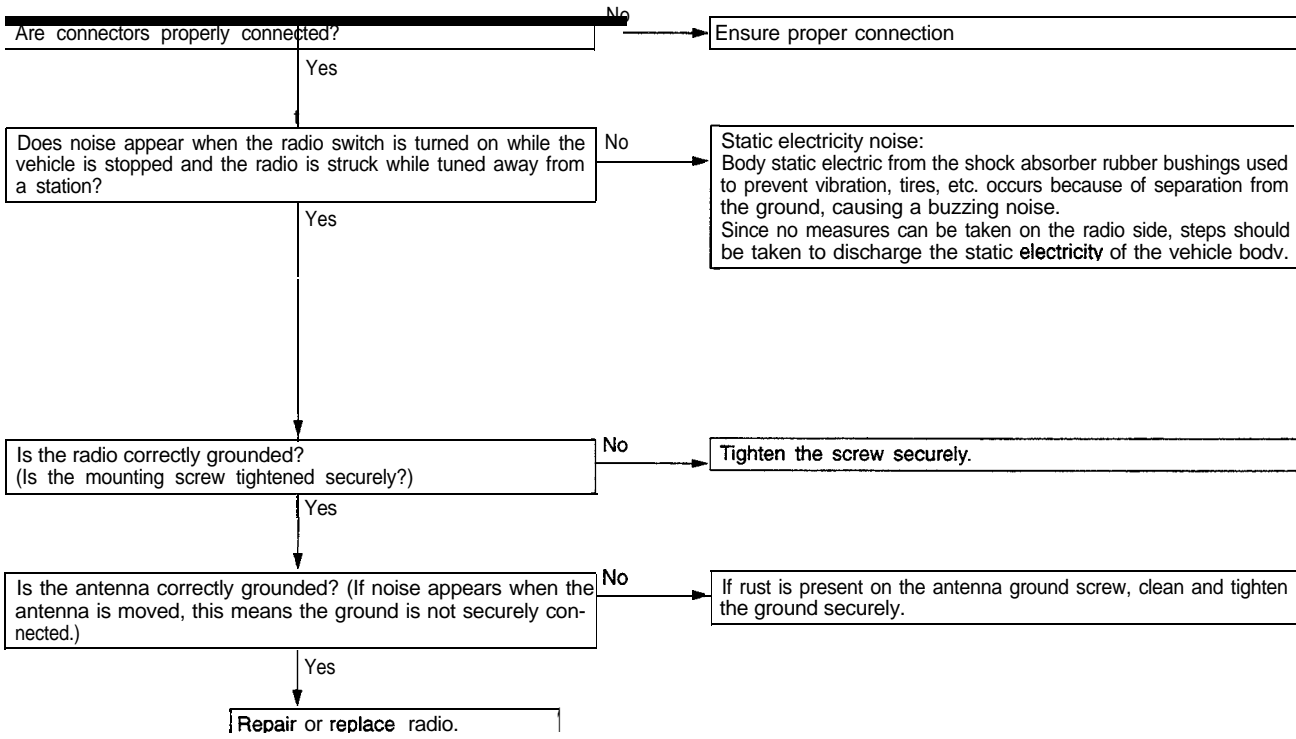

**A-8 Noise sometimes appears on FM during traveling.**

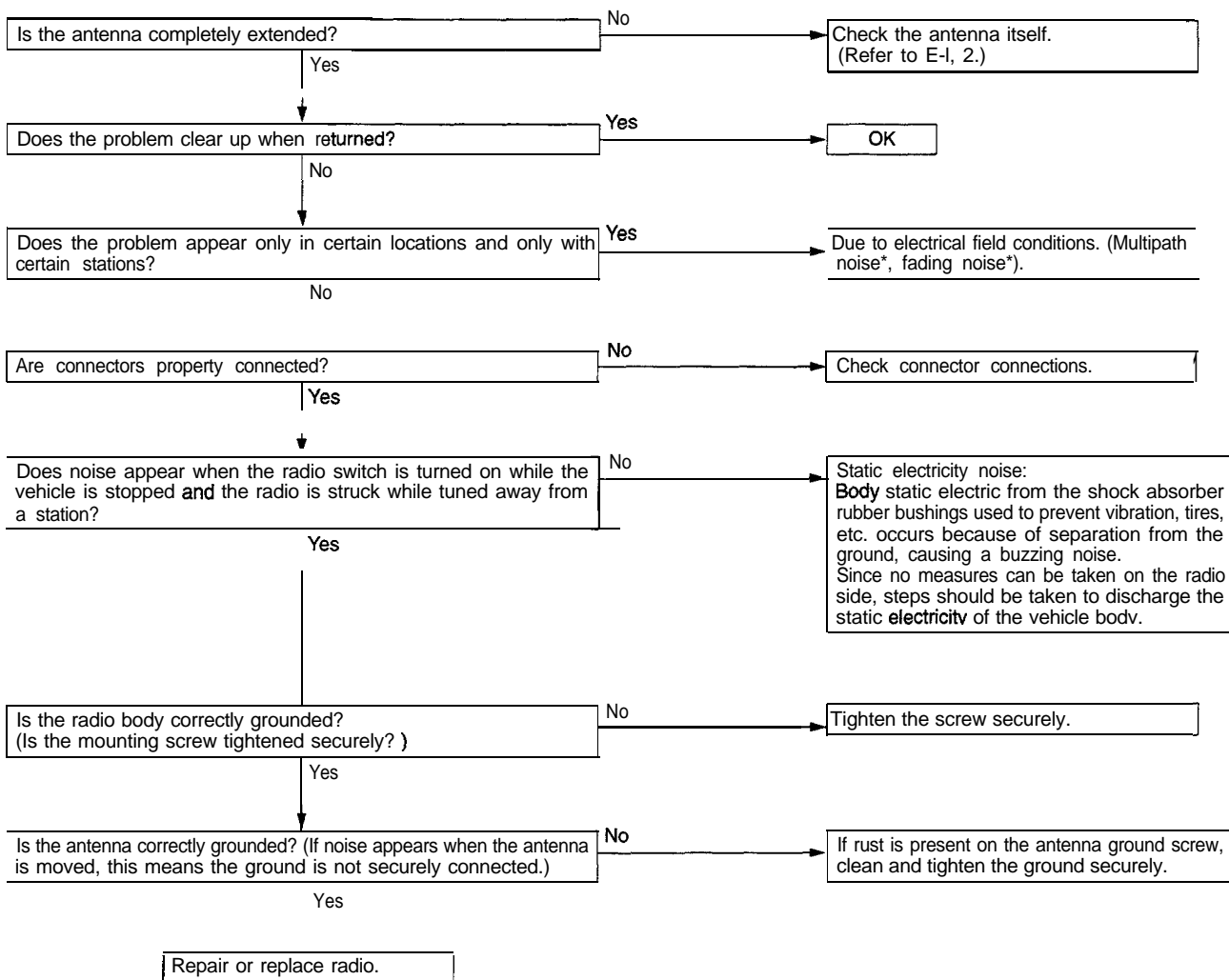

- \* About multipath noise and fading noise  
Because the frequency of FM **waves** is extremely high, it is highly susceptible to effects from geological formations and buildings. These effects disrupt the broadcast signal and obstruct reception in several ways.
- Multipath noise  
This describes the echo that occurs when the broadcast signal is reflected by a large obstruc-

tion and enters the receiver with a slight time delay relative to the direct signal (repetitious buzzing).

- Fading noise  
This is a buzzing noise that occurs when the broadcast beam is disrupted by obstructing objects and the signal strength fluctuates intricately within a narrow range.

**A-9 Ever-present noise.**

Noise is often created by the following factors, and often the radio is OK when it is checked individually.

- Traveling conditions of the vehicle
- Terrain of area traveled through
- Surrounding buildings
- Signal conditions
- Time period

For this reason, if there are still problems with noise even after the measures described in steps A-1 to A-8 have been taken, get information on the factors listed above as well as determining whether the problem occurs with AM or FM, the station names, frequencies, etc., and contact a service center.

**B. RADIO**

**B-1 No power is supplied when the switch is set to ON.**

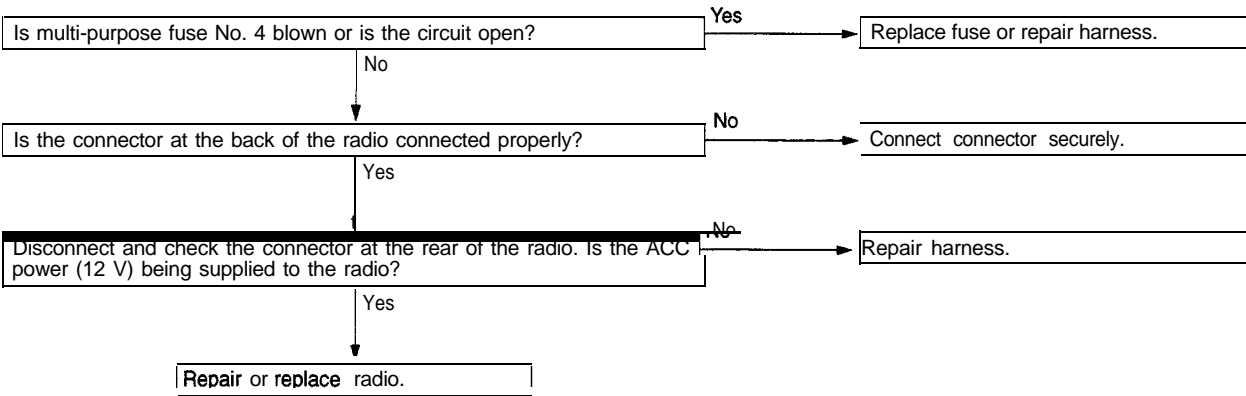

**B-2 No sound from one speaker.**

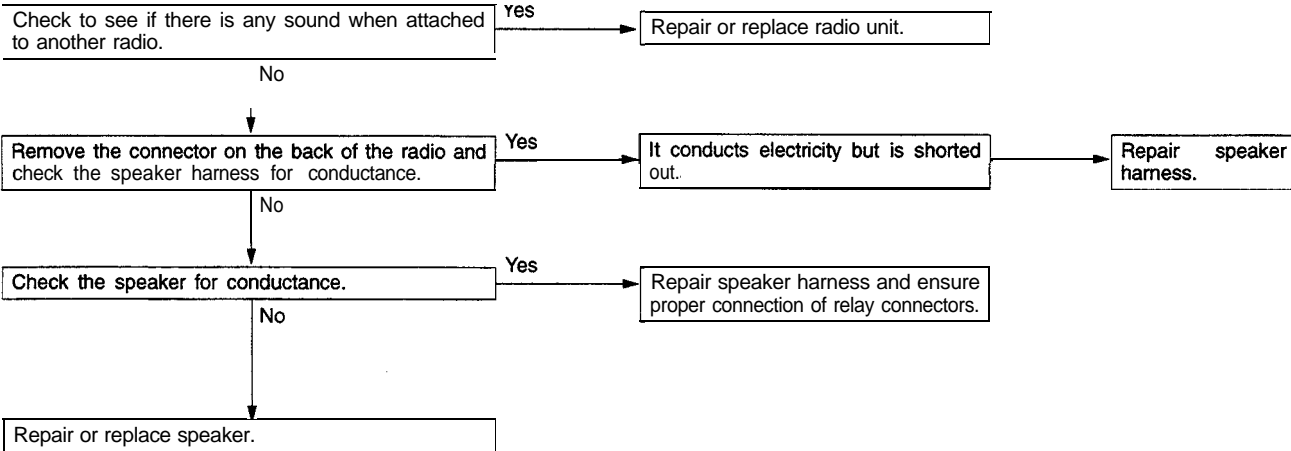

**B-3 There is noise but no reception for both AM and FM or no sound from AM, or no sound from FM.**

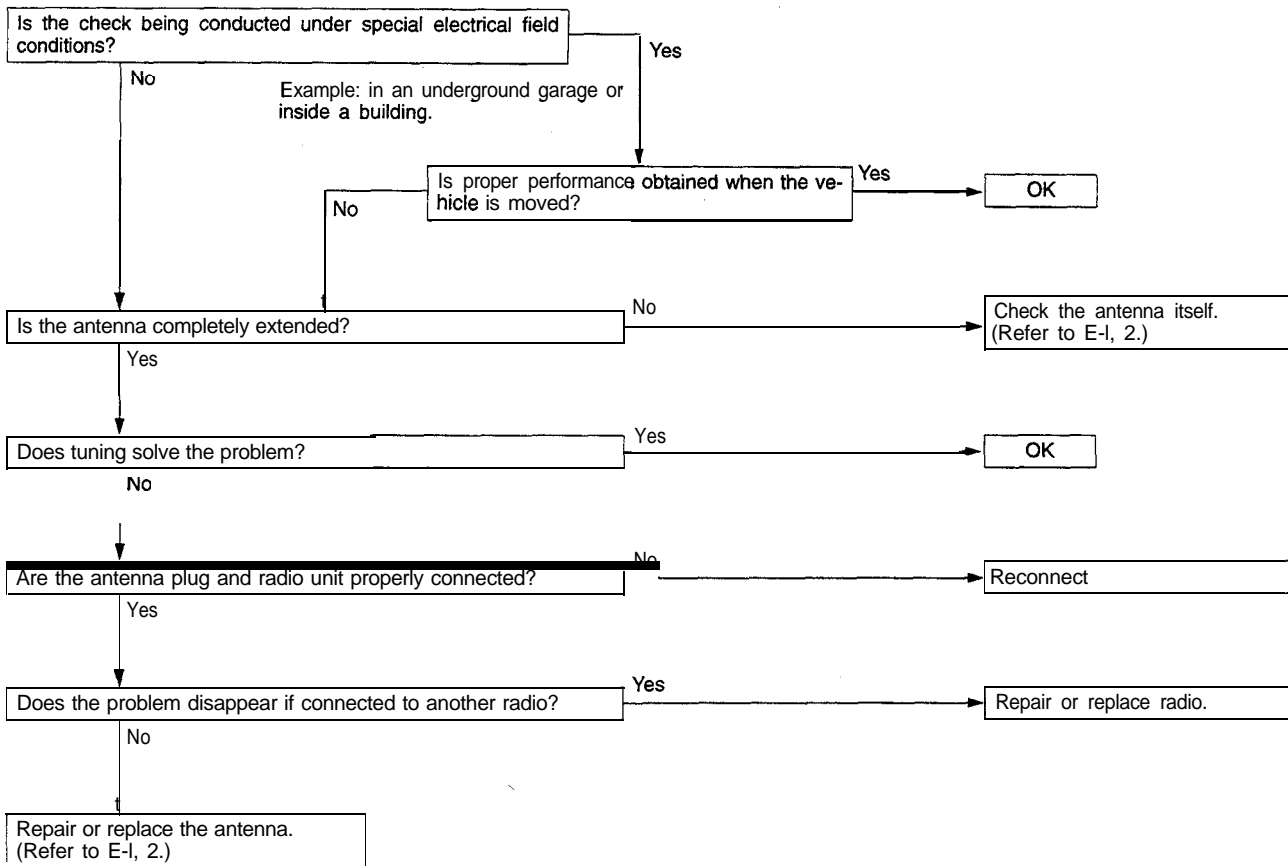

**B-4 Insufficient sensitivity.**

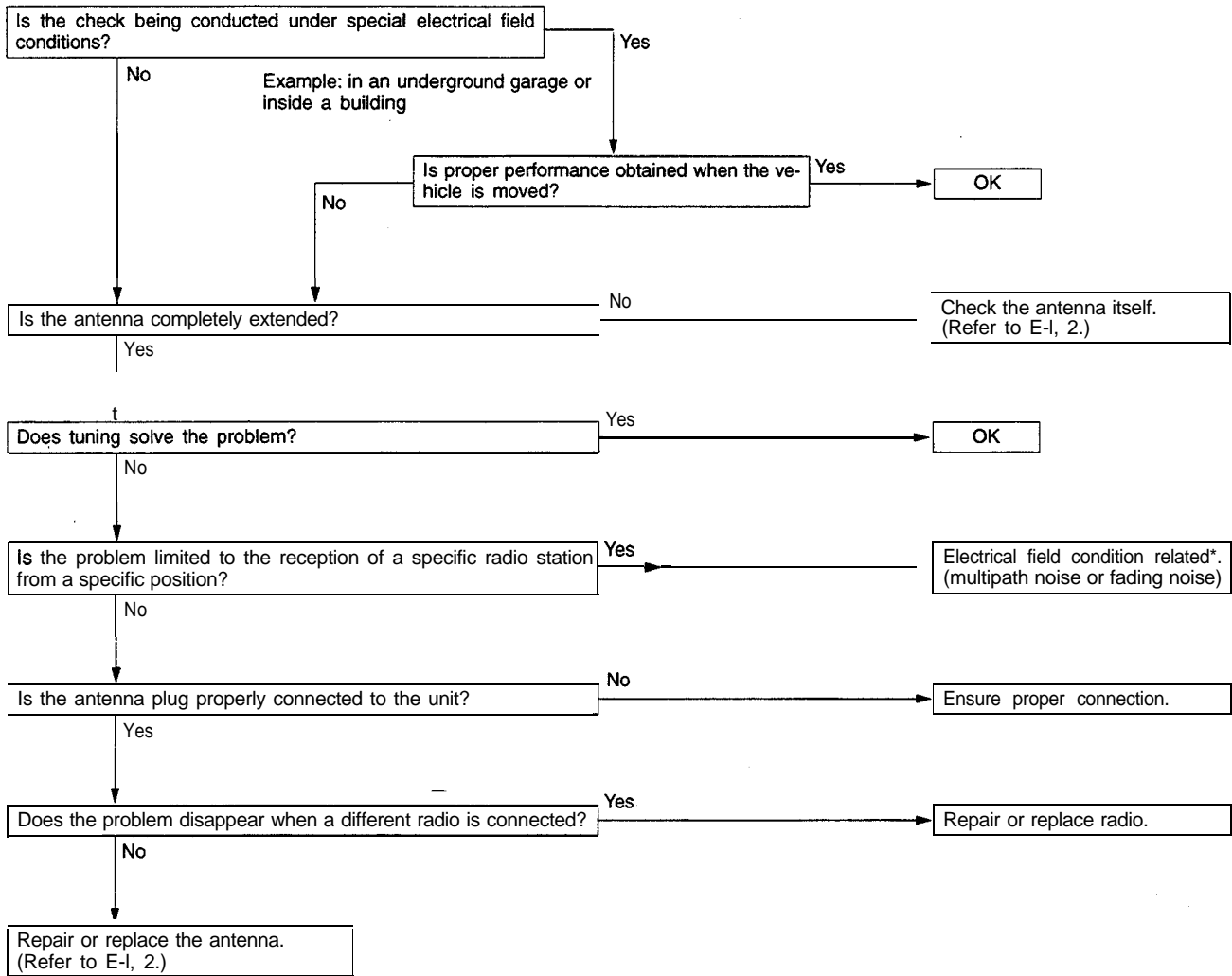

\* For multipath noise and fading noise problems, refer to P.54-167.

**B-5 Distortion on AM or on both AM and FM.**

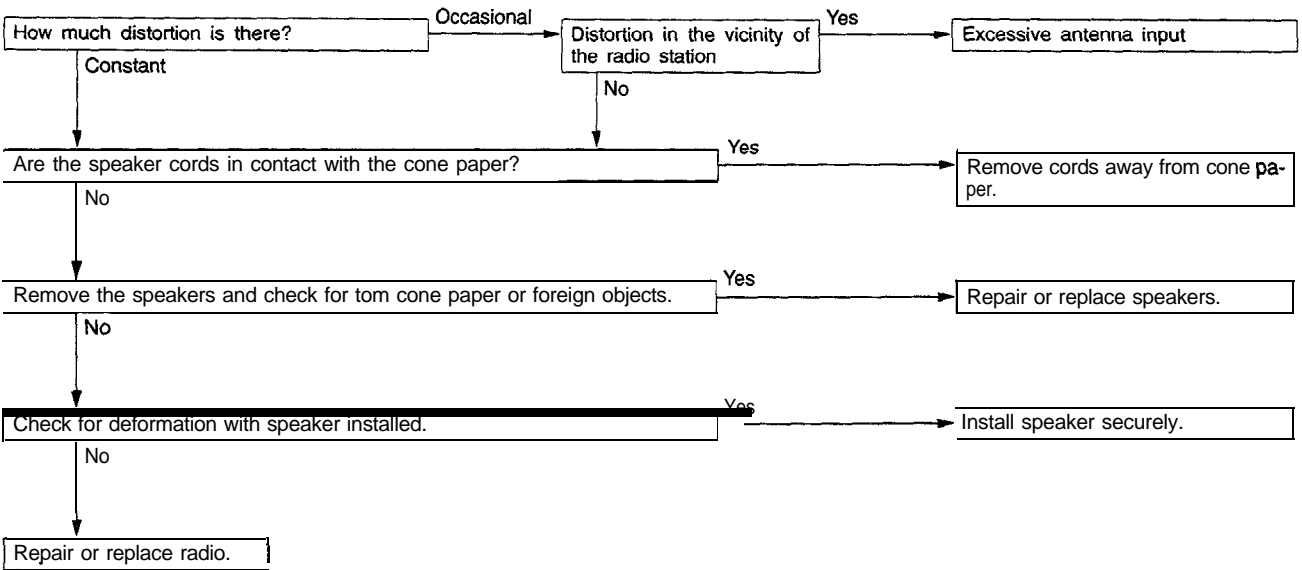

**B-6 Distortion on FM only**

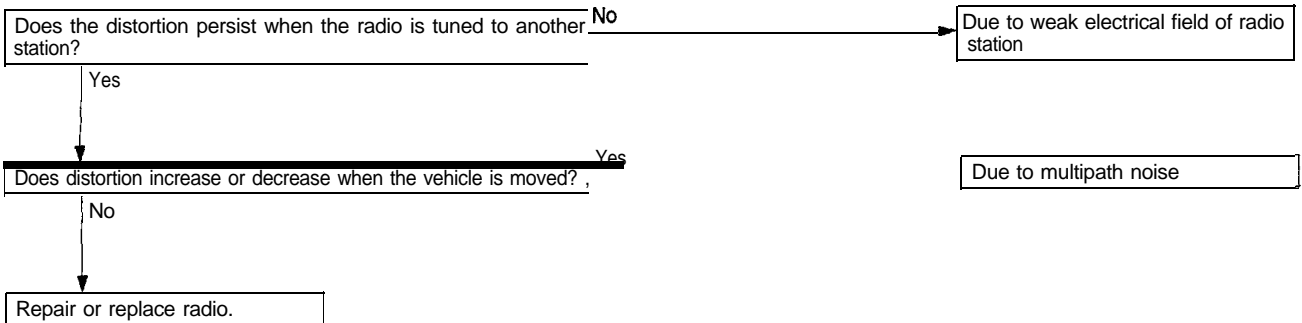



**B-7 Too few automatic select stations.**

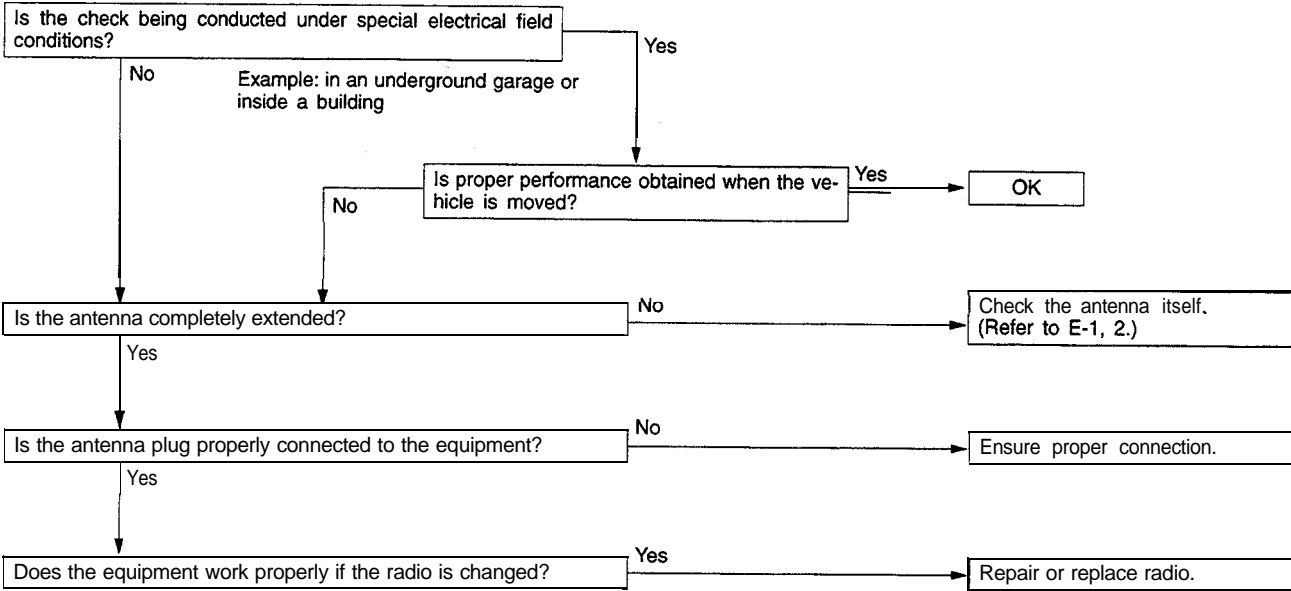

**B-8 Insufficient memory (preset stations are erased).**

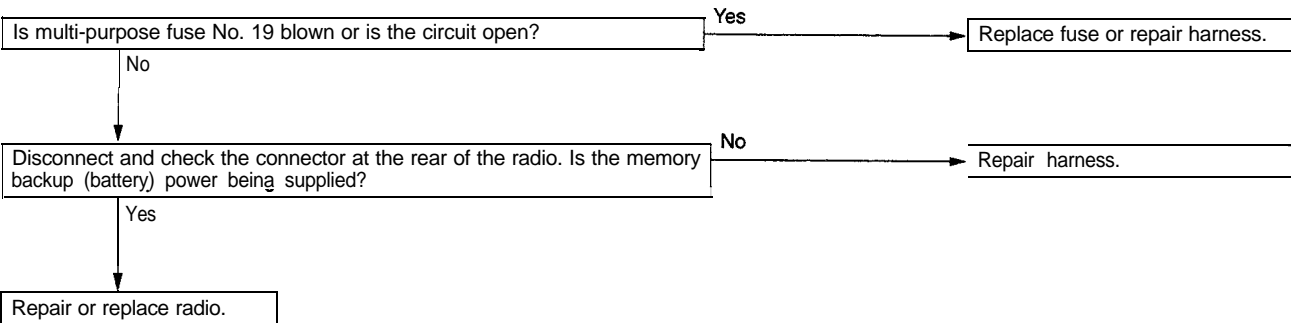

C. CASSETTE PLAYER

**C-1 Cassette tape will not be inserted.**

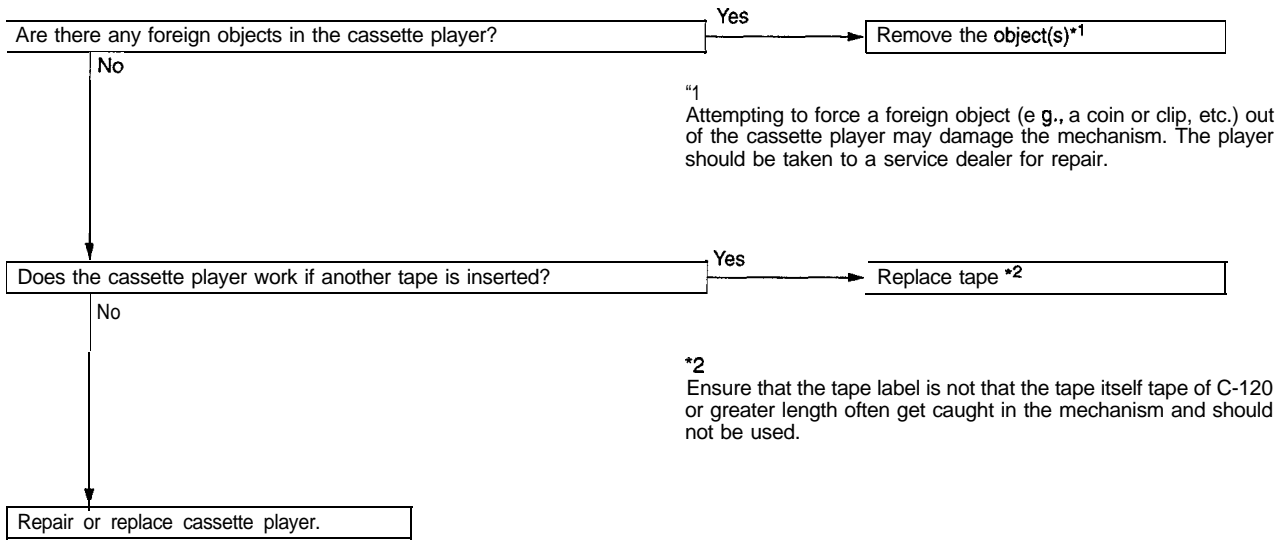

**C-2 No sound (even after a tape has been inserted).**

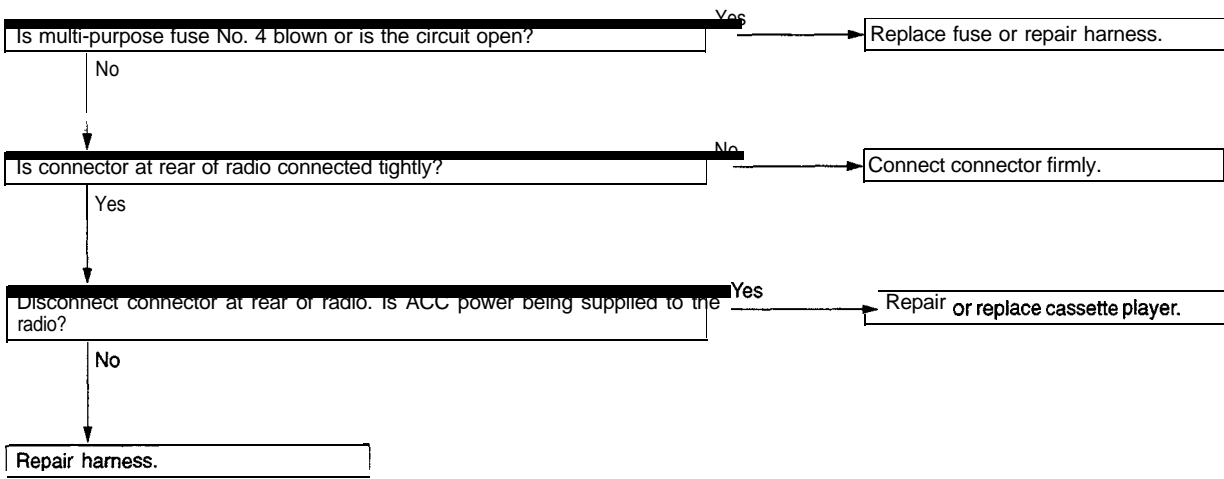

C-3 No sound from one speaker.

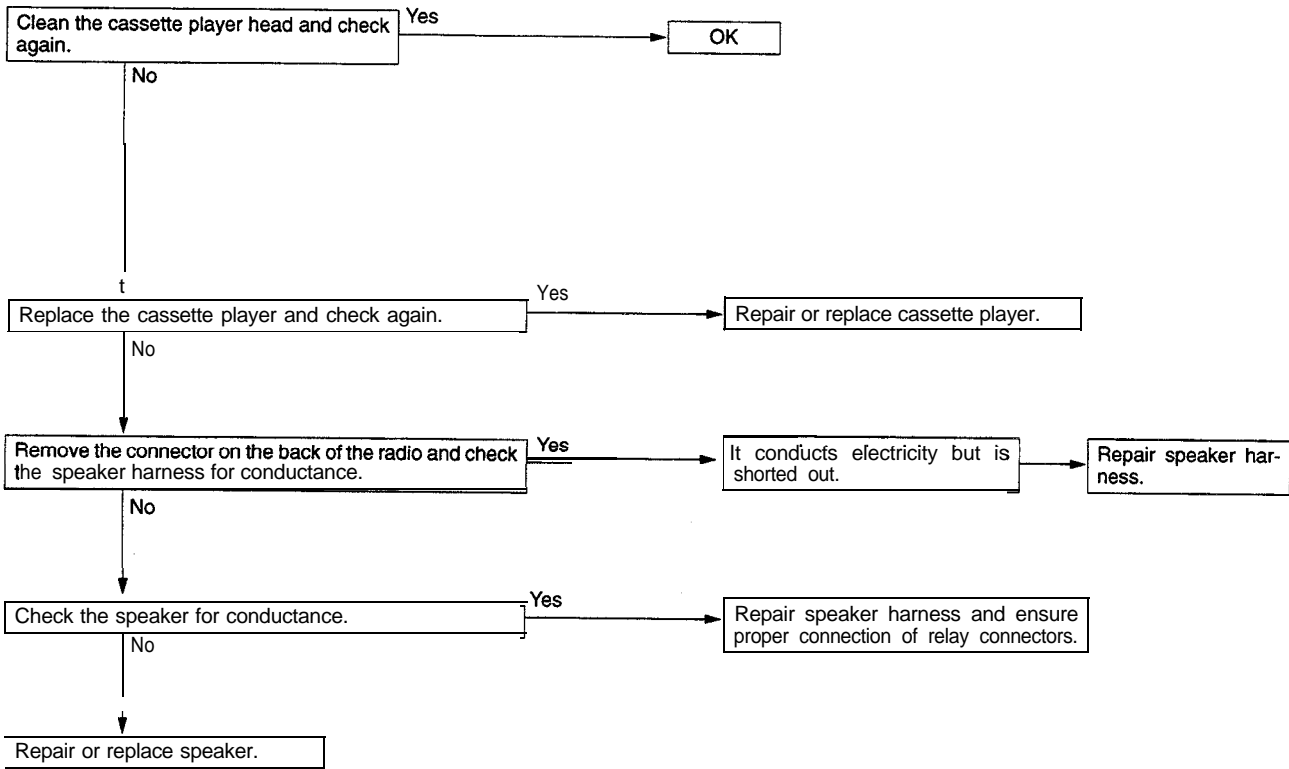

**C-4 Sound quality is poor, or sound is weak.**

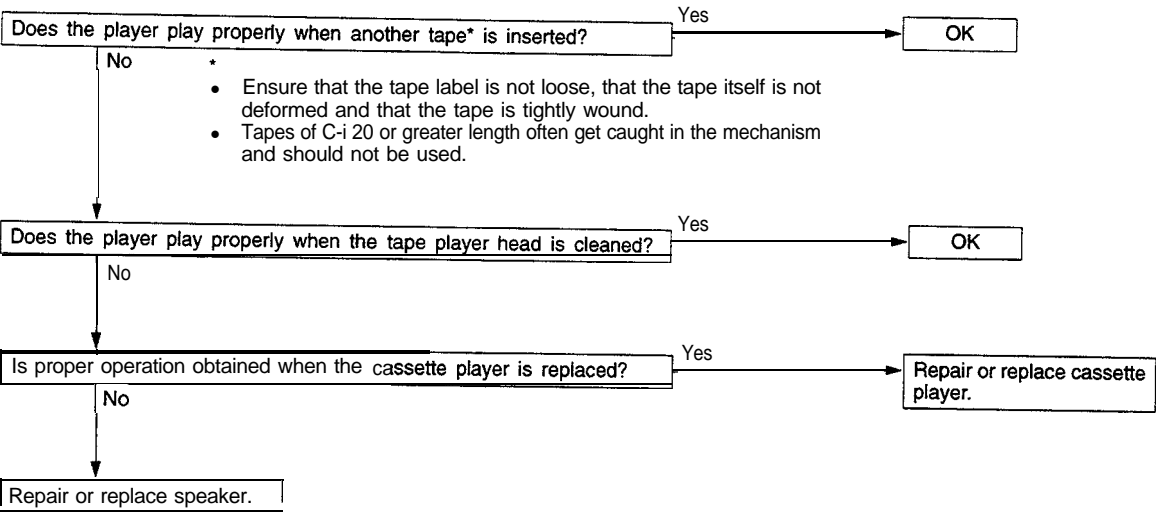

**C-5 Cassette tape will not be ejected.**

The problems covered here are all the result of the use of a bad tape (deformed or not properly tightened) or of a malfunction of the cassette player itself. Malfunctions involving the tape becoming caught in the mechanism and ruining the case are also possible, and attempting to force the tape out of the player can cause damage to the mechanism. The player should be taken to a service dealer for repair.

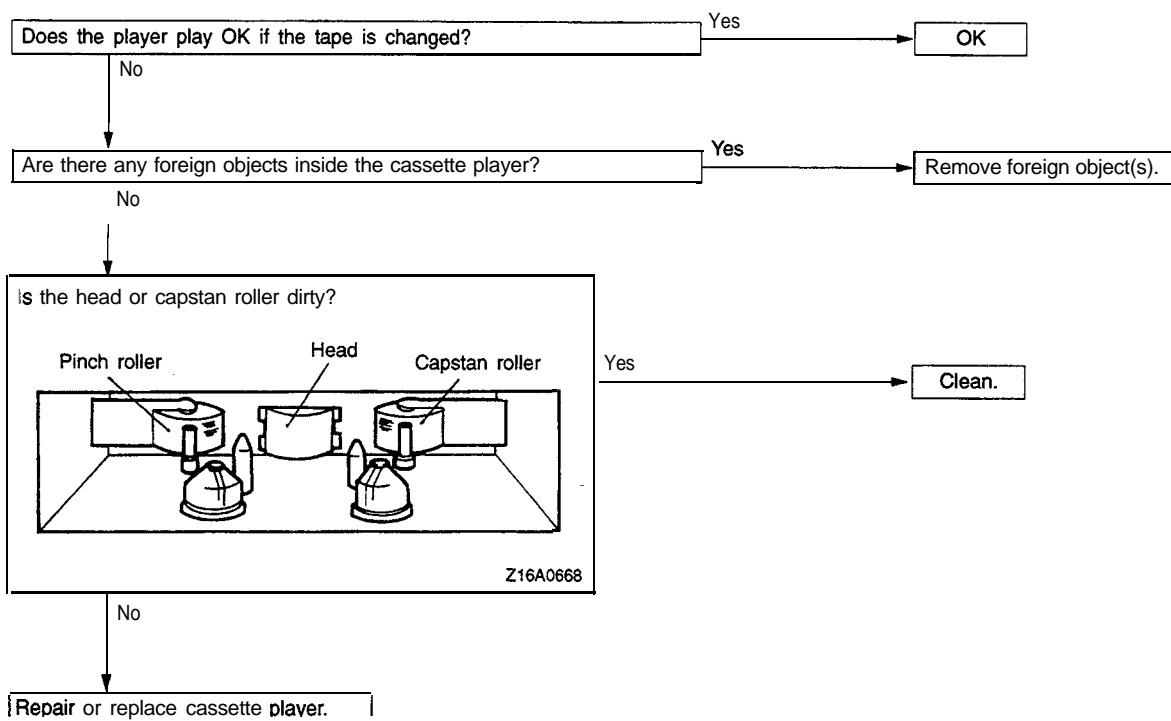
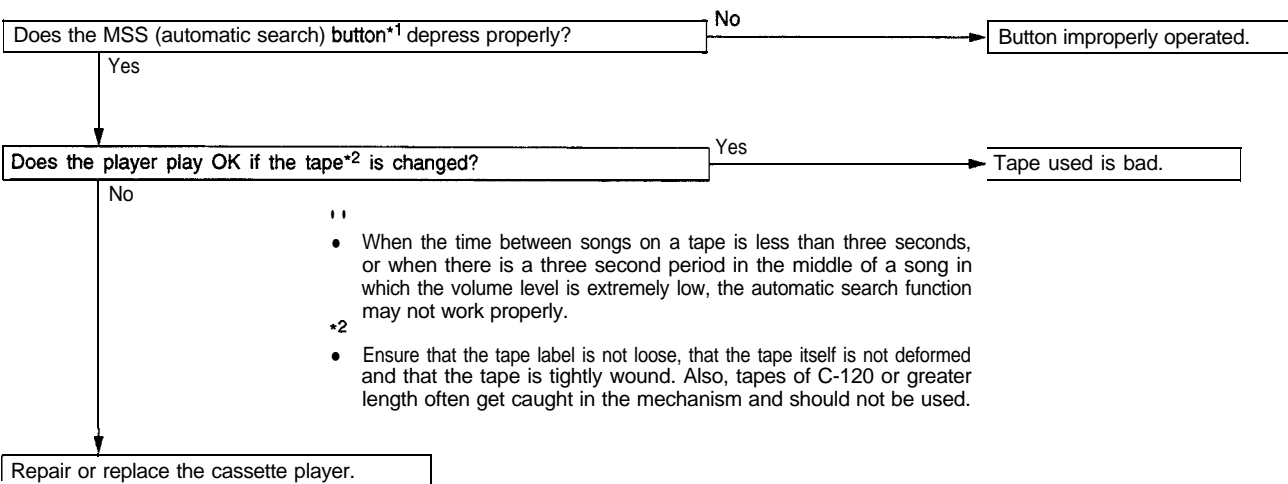
**C-6 Uneven revolution. Tape speed is fast or slow.**

**C-7 Automatic search does not work.**

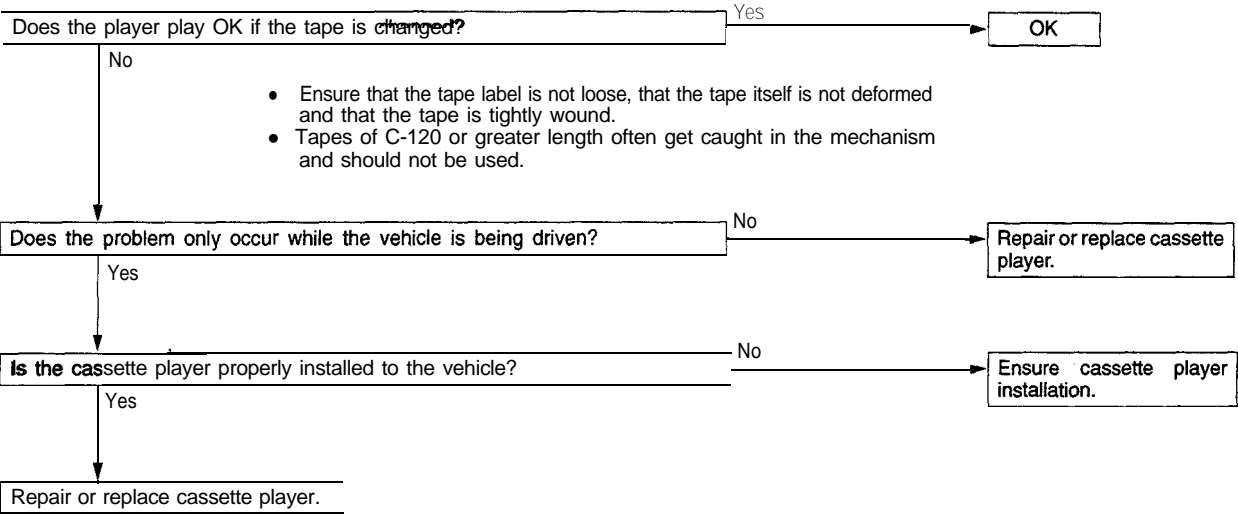
**C-8 Faulty auto reverse.**

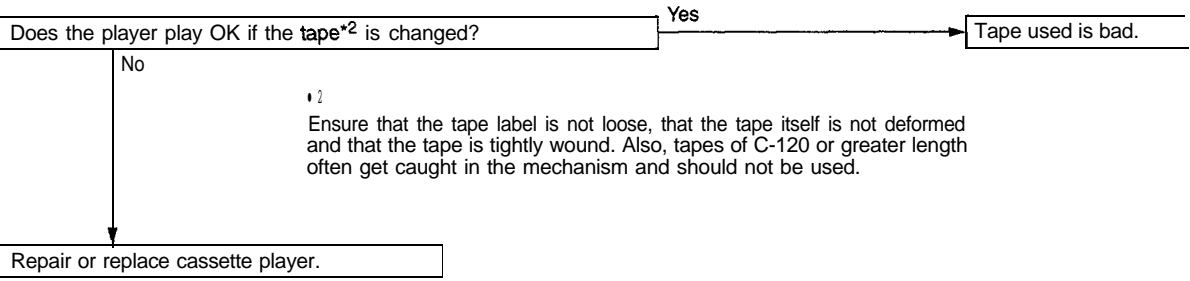

**C-9 Tape gets caught in mechanism\*1.**

\*1  
When the tape is caught in the mechanism, the case may not eject. When this occurs, do not try to force the tape out as this may damage the tape player mechanism. Take the cassette to a service dealer for repair.



## D. CD PLAYER

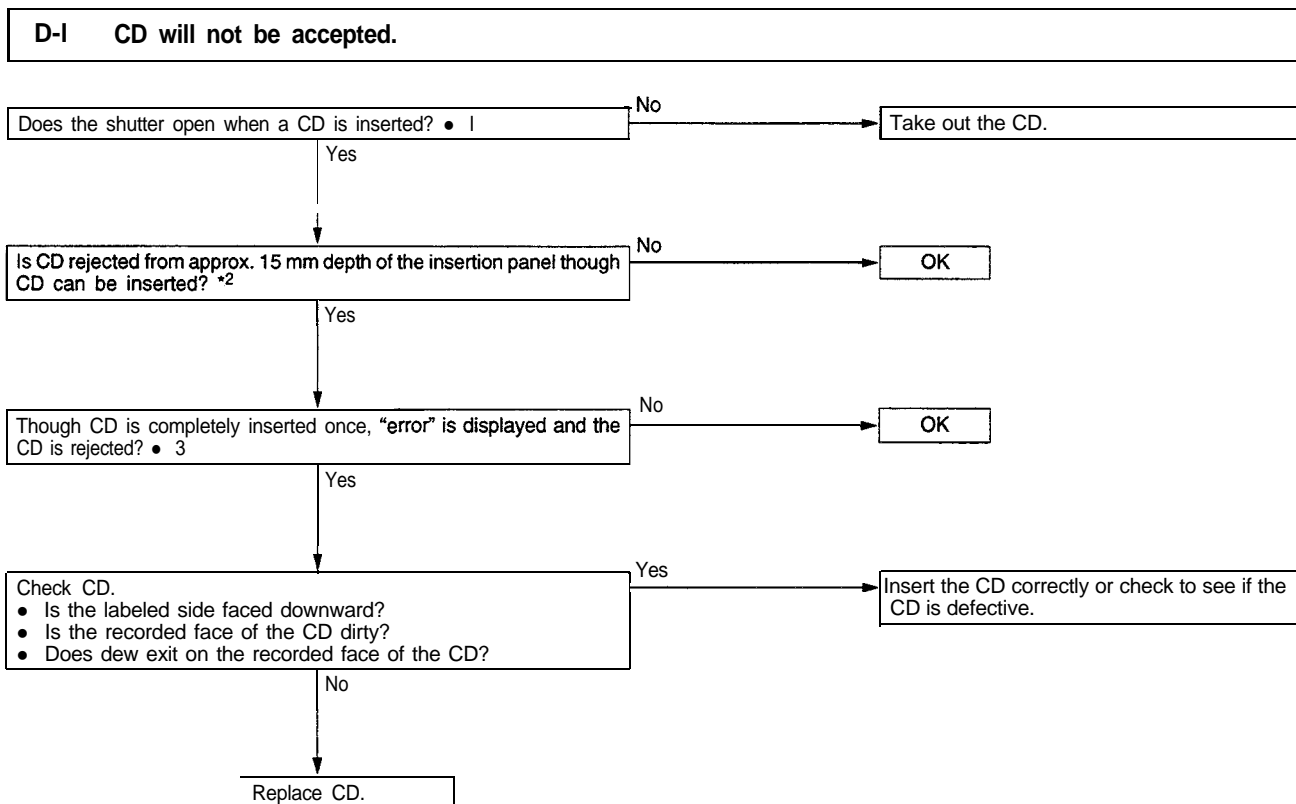

1 If the CD is already loaded, doesn't the shutter open to allow insertion when another CD is inserted?

2 If the key switch is not at ACC or ON, the CD stops at depth of 15 mm below the panel surface even when it is inserted, and it will be rejected when pushed farther?

3 Even though the CD is loaded, E (error) is sometimes displayed with the CD rejected because of vibration/ shock or dew on the CD face or optical lens.

D-2 No sound.

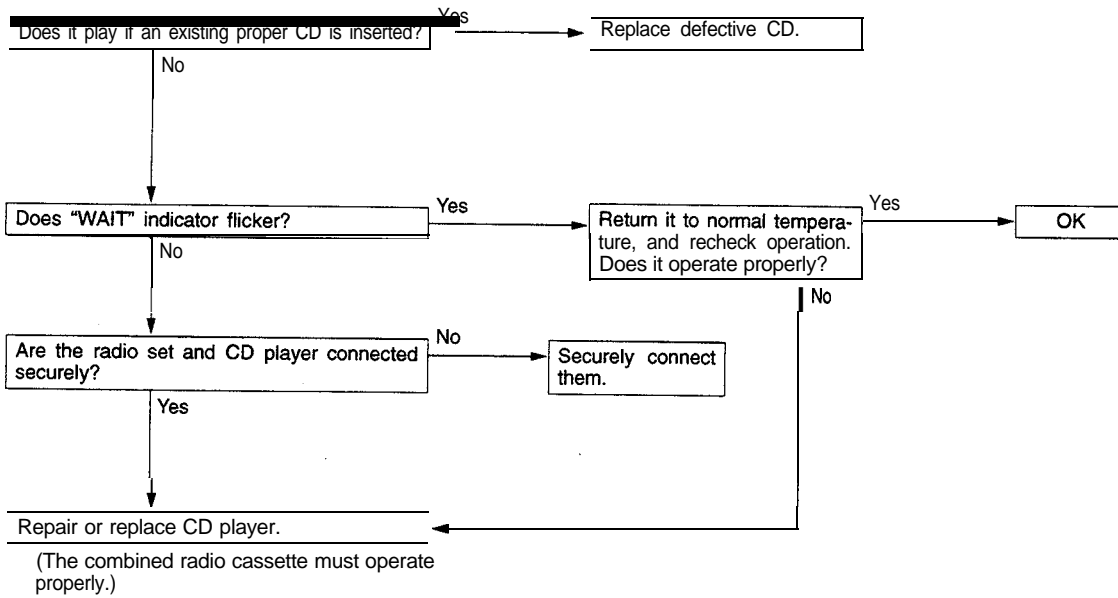

D-3 CD sound skips.

1. Sound sometimes skips during parking.

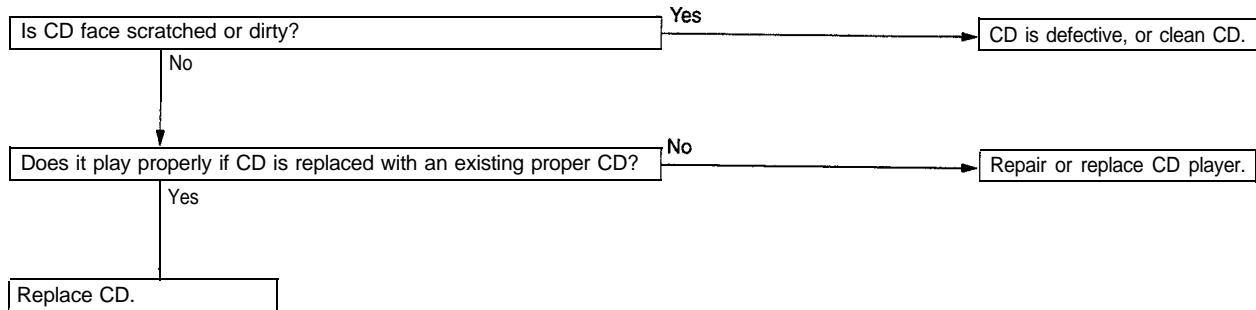

2. Sound sometimes skips during driving.

(Stop vehicle, and check it.)  
 (Check it by using a proper CD which is free of scratch, dirt or other abnormality.)

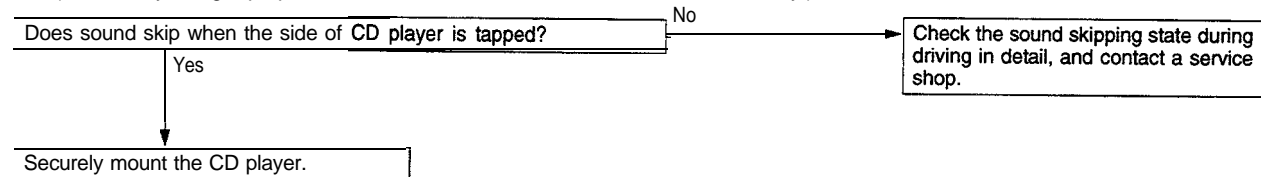



**D-4 Sound quality is poor.**

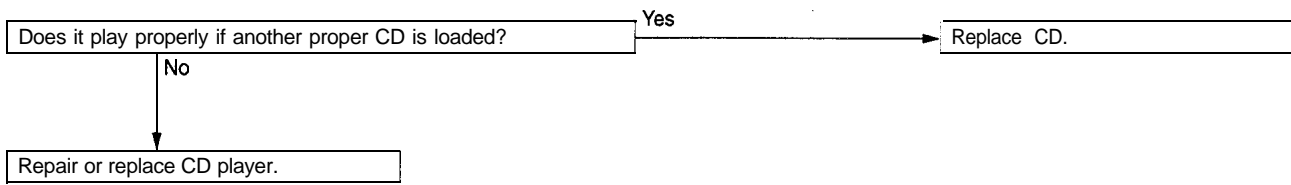

**D-5 CD will not be ejected.**

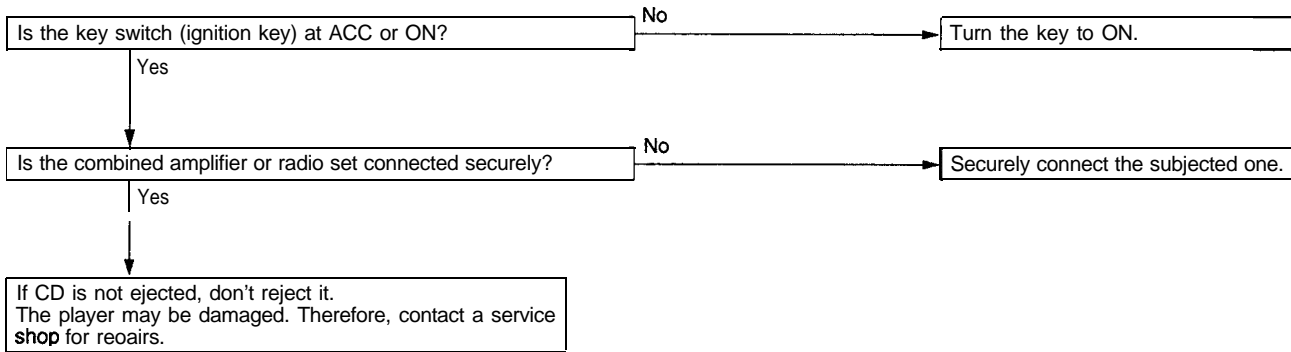

**D-6 No sound from one speaker.**

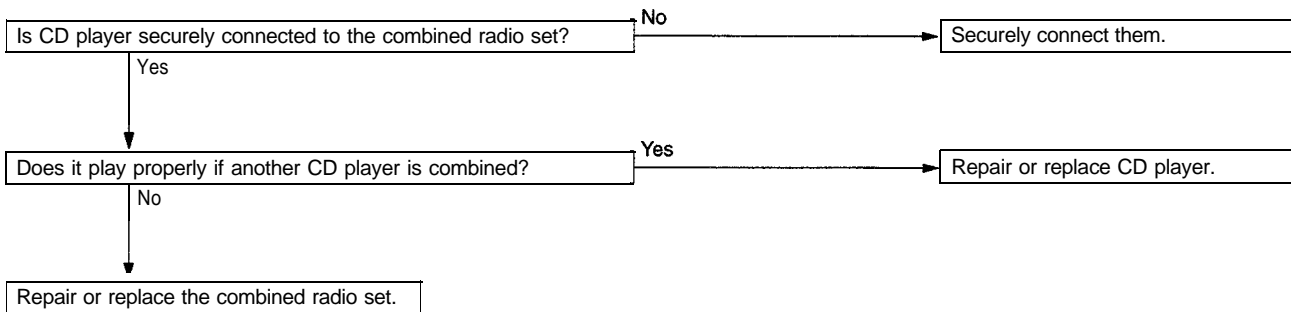

E. MOTOR ANTENNA

**E-1 Motor antenna won't extend or retract.**

Clean and polish the surface of the antenna rod.

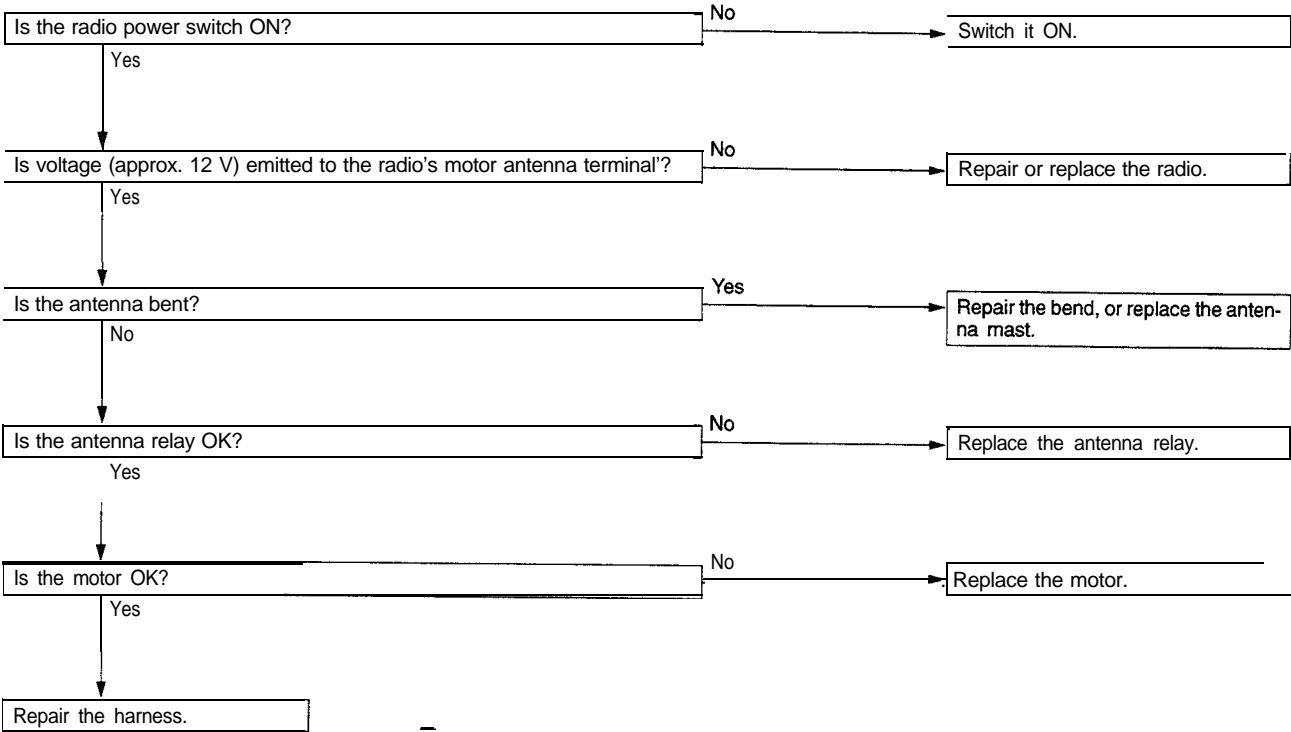

E-2 Motor antenna extends and retracts but does not receive.

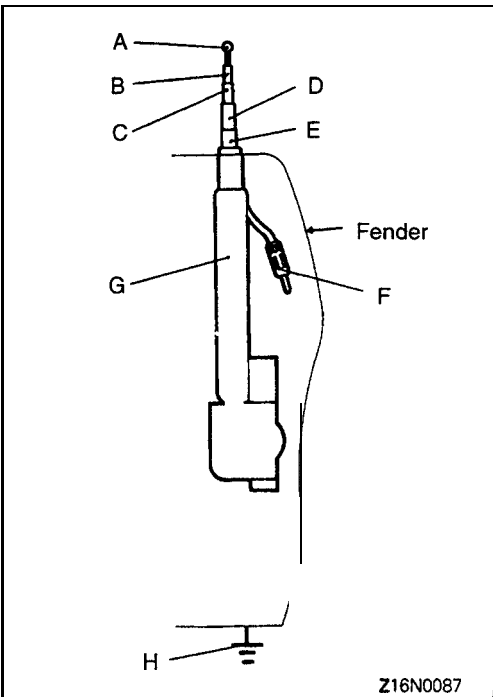
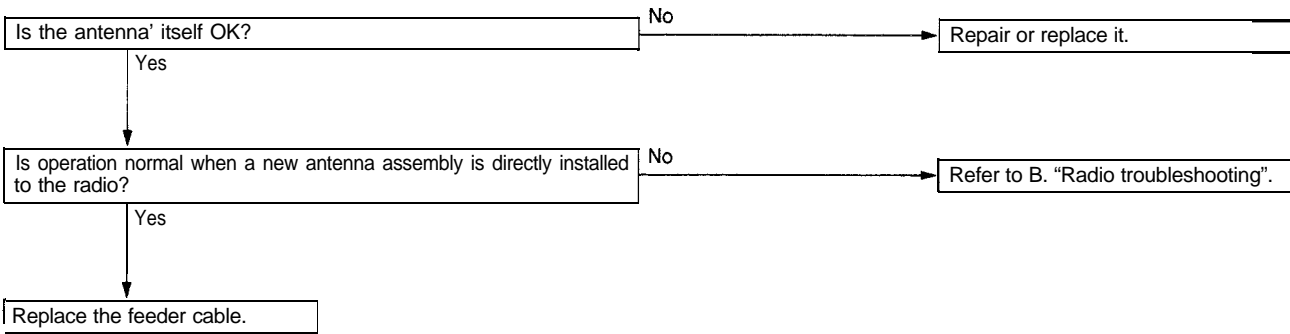

Checking the antenna \*

Ohmmeter measurement locations	Result
Circuits from F to A, B, C, D and E	Continuity
Circuit between G and H	Continuity
Circuits from H to A, B, C, D and E	No continuity

**PROCEDURE FOR INPUT OF SECURITY CODE FOR RADIO AND TAPE PLAYER WITH ANTI-THEFT SYSTEM**

The radio and tape player does not operate in the following states.

- (1) Power supply to the radio and tape player has been suspended for more than one hour continuously by removing the cable from the battery terminal or disconnecting the harness connectors.
- (2) The power supply to the radio and tape player has been suspended for more than one hour owing to blown fuse or discharged battery.
- (3) The radio and tape player has been replaced.

If the radio and tape player does not operate for these causes, input the security code by the following procedure to operate it.

1. Using any of the following methods, confirm the security code.
  - (1) Read the security code indicated on the cards retained by the user.
  - (2) If the security code is unknown owing to the user's loss of the cards,
    - a. Remove the audio panel and then pull out the radio and tape player partially.
    - b. Read the serial No. shown on the name card of the radio and tape player.
    - c. Look up the anti-theft code corresponding to the serial number in the serial number-anti-theft code table; or, make inquiries to Mitsubishi Motor Sales of America, Inc.

- (3) When the radio and tape player is replaced  
Read the security code on the cards attached to the upper surface of the replacement radio and tape player.

**NOTE**

Deliver the cards (two) to the user.

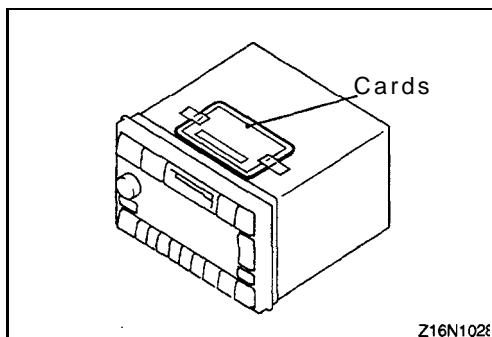
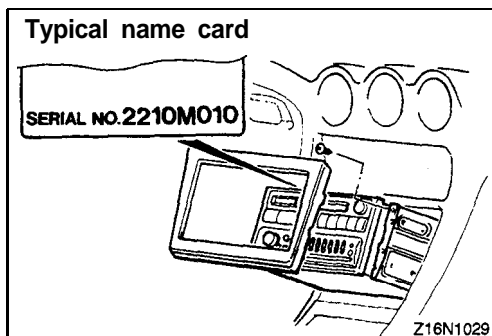

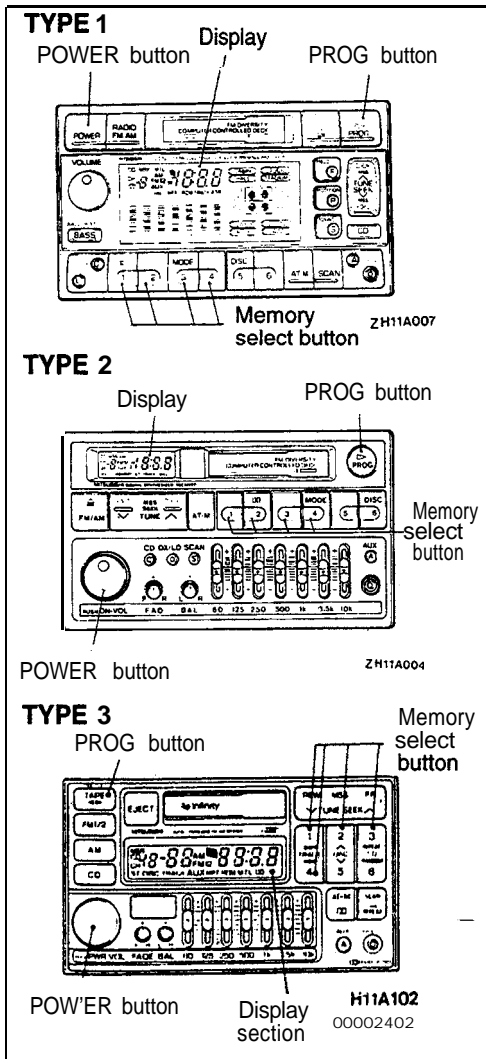

2. Return power supply for the radio and player to the normal state.
3. Turn the ignition key to the "ACC" position.
4. Press the POWER button, and "code" will be displayed on the display.

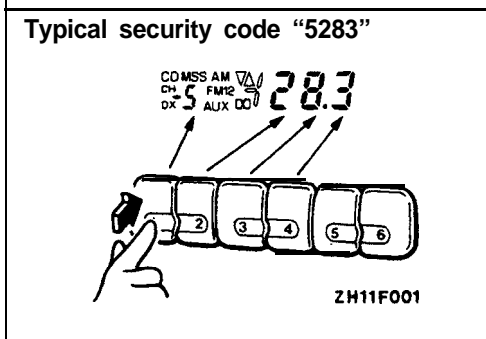

5. Press No.1 through No.4 memory select buttons and set the 4-digit security code indicated on the card.

Every time each digit key is pressed, the number changes as follows:

→ 0 → 1 → 2 ... 9 → 0 ...

6. Press the PROG button. After a beep is heard, the radio and tape player will be in the operating state.
7. If the input security code does not agree with that in memory, "1 Err" is displayed on the display. In a few seconds, it will change to "code". So, repeat steps 4 and 5.

**NOTE**

- (1) The security code can be set three times at the most.
- (2) The second error is displayed as "2 Err". If the third error is made, "3 Err" is displayed and then it changes to "OFF".
- (3) When setting is attempted four or more times, keeping the ignition key in the "ACC" or "ON" position for about one hour will automatically erase the "OFF" display.

After the erasing, therefore, repeat step 3 and up. If the ignition key is turned to the "OFF" position during one-hour period of keeping it in "ACC" or "ON" position, the "OFF" display will be erased.

With the ignition key placed in the "ACC" position again, press the POWER button, and the "OFF" display will be resumed. Therefore, keep this state for another one hour or so.

## RADIO REMOTE-CONTROL

## REMOVAL AND INSTALLATION

**CAUTION: SRS****<Up to 1993 models>**

Before removal of air bag module, refer to GROUP 52B – Service Precautions and Air Bag Module and Clock Spring.

**<From 1994 models>**

When removing and installing the remote control switch, don't allow any impact or shock to the air bag module.

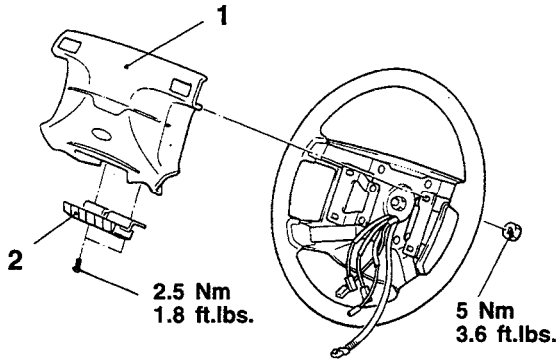
**<Up to 1993 models>**

Z16F0208

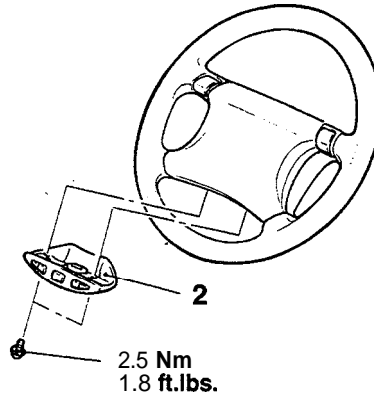
**<From 1994 models>**Z16F0491  
00002403**Removal steps**

1. Air bag module (Refer to GROUP 52B – Air Bag Module and Clock Spring.)
2. Radio remote control switch

## RADIO AND TAPE PLAYER

## REMOVAL AND INSTALLATION

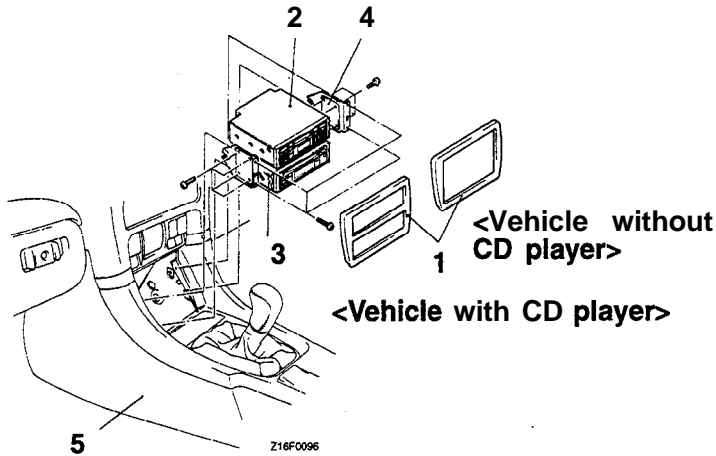

Z16F0096

**Removal steps**

1. Radio panel
2. Radio and tape player
3. CD player
4. Radio bracket
5. Front console assembly (Refer to GROUP 52A – Console Box.)

TSB Revision

**SPEAKER**

**REMOVAL AND INSTALLATION**

**<DOOR SPEAKER>**

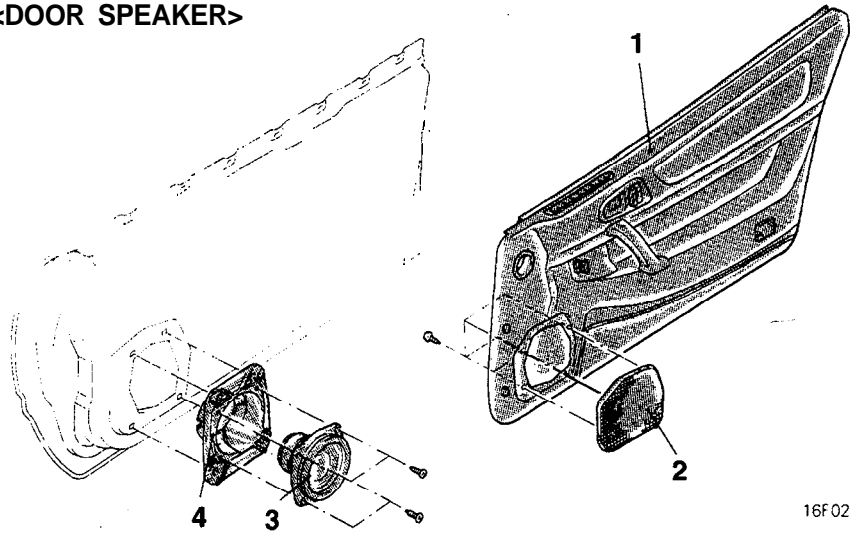

16F0279

**<REAR SPEAKER>**

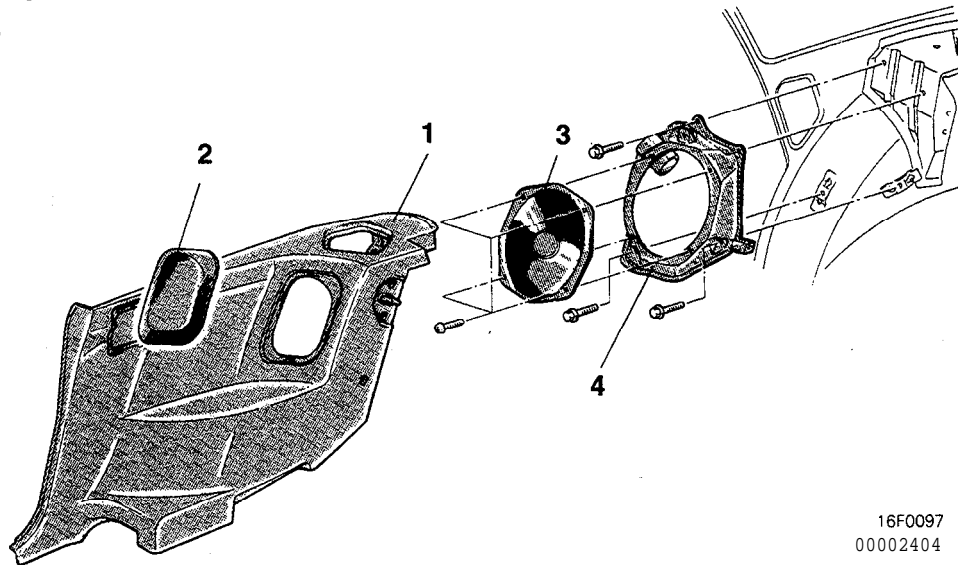

16F0097  
00002404

**Door speaker removal steps**

1. Door trim (Refer to GROUP 42 – Door Trim and Waterproof Film.)
2. Speaker garnish
3. Speaker
4. Speaker cover

**Rear speaker removal steps**

1. Quarter trim (Refer to GROUP 52A – Trims.)
2. Speaker garnish
3. Speaker
4. Speaker box



# MOTOR ANTENNA / ANTENNA FEEDER CABLE / AMPLIFIER REMOVAL AND INSTALLATION

<Hatchback>

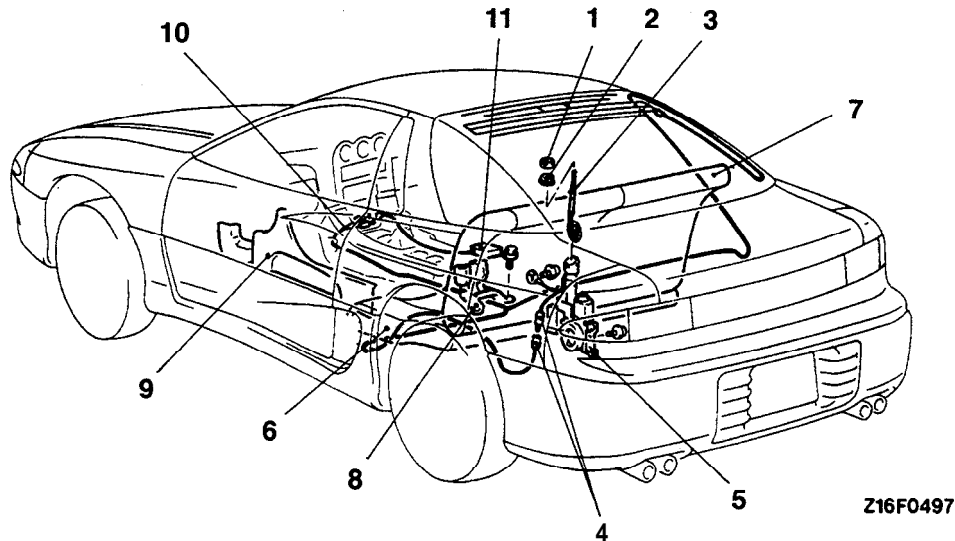

### Motor antenna removal steps

- Rear side trim (LH)  
(Refer to GROUP 52A – Trims.)
- 1. Ring nut
- 2. Base
- 3. Antenna pole
- 4. Antenna feeder cable and motor antenna connection
- 5. Motor antenna

### Amplifier removal

- 11. Amplifier (under passenger's seat)

### NOTE

- : Refer to GROUP 52A – Trims
- \*2: Vehicles with glass mounted antenna

### Antenna feeder cable removal steps

- Rear side trim (LH)\*1
- Quarter trim (LH)\*1
- Rear side trim\*1 \*2
- Quarter trim (LH)\*1 \*2
- Quarter upper trim\*1, ● \*
- Liftgate upper trim\*1 \*2
- Liftgate side trim (RH)\*1, ● \*
- Rear console assembly  
(Refer to GOUP 52A – Console Box.)
- Radio and tape player  
(Refer to P.54-176)
- 4. Antenna feeder cable and motor antenna connection
- 6. Rear seat cushion
- 7. Rear seatback
- 8. Inner seat belt
- 9. Console side cover (LH)
- 10. Antenna feeder cable



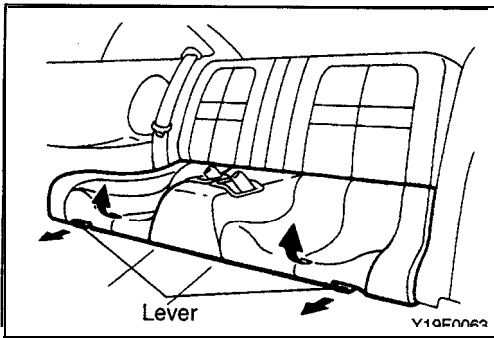

**REMOVAL SERVICE POINT**

**◀A▶ REAR SEAT CUSHION REMOVAL**

Raise and remove the seat cushion with the lever pulled.

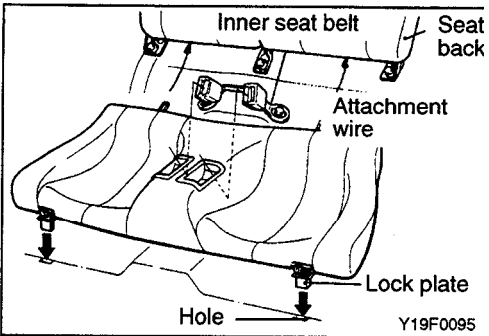

**INSTALLATION SERVICE POINT**

**▶A◀ REAR SEAT CUSHION INSTALLATION**

- (1) Securely fit the attachment wire of the seat cushion under the seatback.
- (2) Pass the inner seat belt buckles through the cushion.
- (3) Securely fit the lock plates of the seat cushion into the holes in the floor.

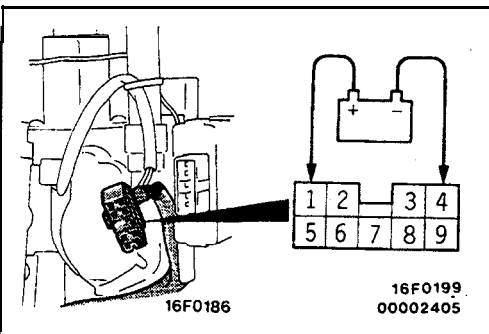

**INSPECTION**

**ANTENNA MOTOR INSPECTION**

Disconnect the motor antenna control unit connector, connect the positive terminal of the power supply to terminal (1) and connect the negative terminal to terminal (4) to check that the antenna goes up, and that when the connections are reversed, the antenna goes down.

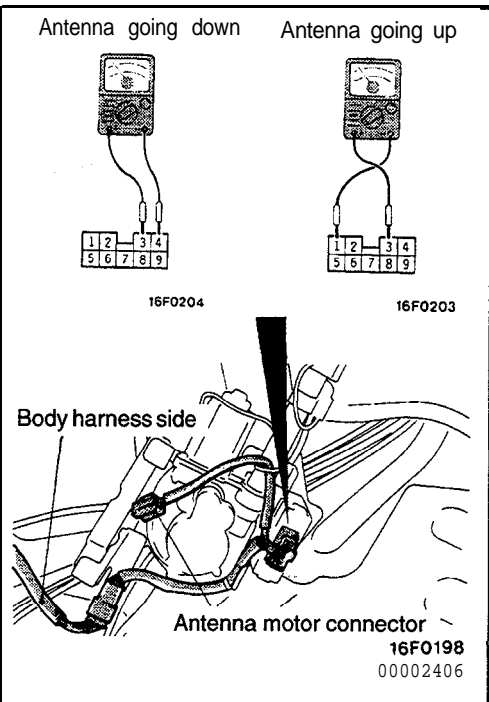

**MOTOR ANTENNA CONTROL UNIT INSPECTION**

- (1) Connect the harness connector to the motor antenna. (Body harness)
- (2) Disconnect the antenna motor connector.
- (3) With the ignition switch in the ACC or ON position, operate the radio switch and check the voltage between the terminals during the period when the antenna is going up or going down.

Antenna operating direction	Terminals to check	Voltage (V)
Down	1 - 3	10-13
Up	3 - 4	10-13

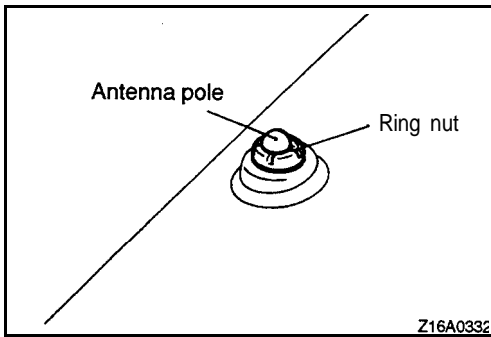
**ANTENNA POLE REPLACEMENT**

(1) Remove the ring nut.

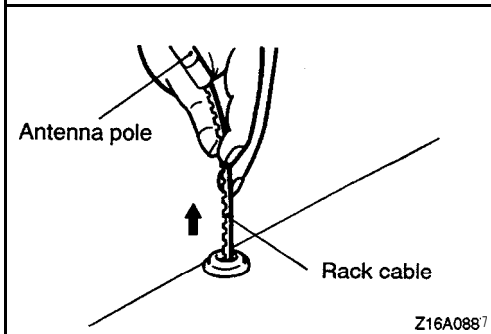

(2) Set the radio switch to ON. After the antenna pole has extended, remove the antenna pole and rack cable as an assembly.

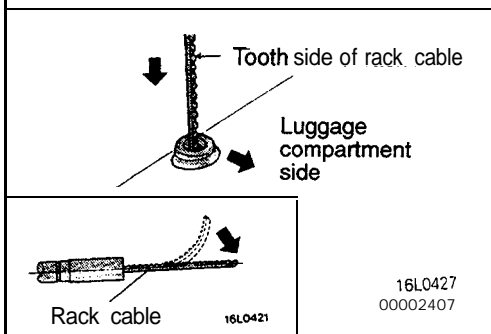

(3) Extend the antenna pole up to its farthest point.

**NOTE**

If the motor end of the rack cable is bent, straighten it.

(4) Force the rack cable into the motor assembly with the tooth side of the rack cable toward the luggage compartment.

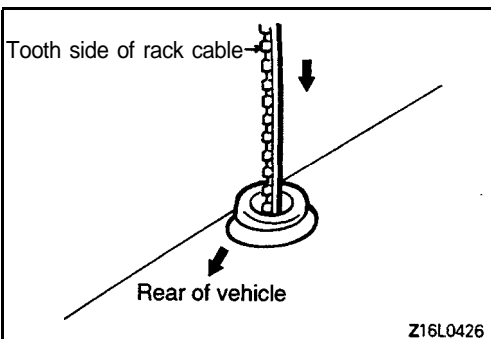

(5) Turn the tooth side of the rack cable toward the rear of the vehicle (90° clockwise) to bring the rack cable into mesh with the motor gear.

(6) Lightly pull the rack cable. If it comes out without resistance, it means that the rack cable is not in mesh with the motor gear. Recheck that the rack cable end is not bent before repeating the above-mentioned steps (2) and (3).

(7) With the antenna pole upright and the radio switch at OFF, take up the rack cable. As the rack cable is taken up, insert the antenna pole toward the motor antenna.

(8) After the ring nut has been tightened, set the radio switch to ON and OFF to check the operation of the antenna pole.

## CD AUTO CHANGER

### REMOVAL AND INSTALLATION

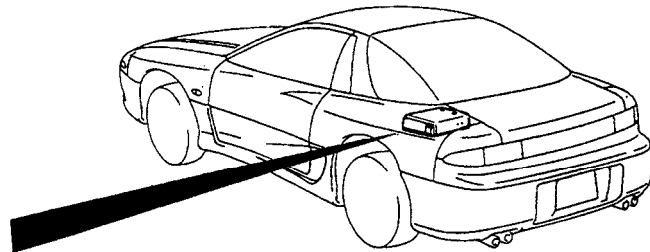
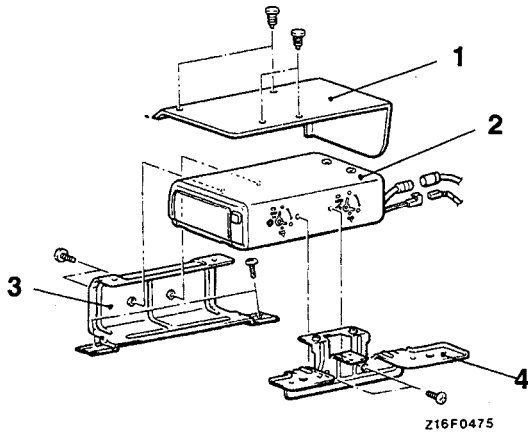





Z16F0495  
00002408

#### Removal steps

1. CD changer cover
  - Luggage compartment floor carpet, high floor center board.
2. CD auto changer
3. CD changer bracket (front)
4. CD changer bracket (rear)

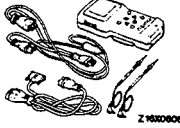
**REAR WINDOW DEFOGGER****SPECIAL TOOLS**

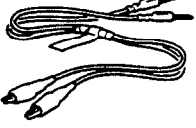
Tool	Tool number and name	Supersession	Application
	MB991341 Scan tool (Multi-use tester <MUT>)	MB991341C	Up to 1993 models Checking the rear window defogger system
	ROM Pack (For the number, refer to GROUP 00 – Precautions Before Service.)		
	MB991502 Scan tool (MUT-II)	MB991502	All models Checking the rear window defogger system
 Z16X0607	ROM pack		
	MB991529 Diagnostic trouble code check harness	MB991529	From 1994 models Checking the rear window defogger system using a voltmeter

TROUBLESHOOTING

CIRCUIT DIAGRAM  
(UP TO 1993 MODELS)

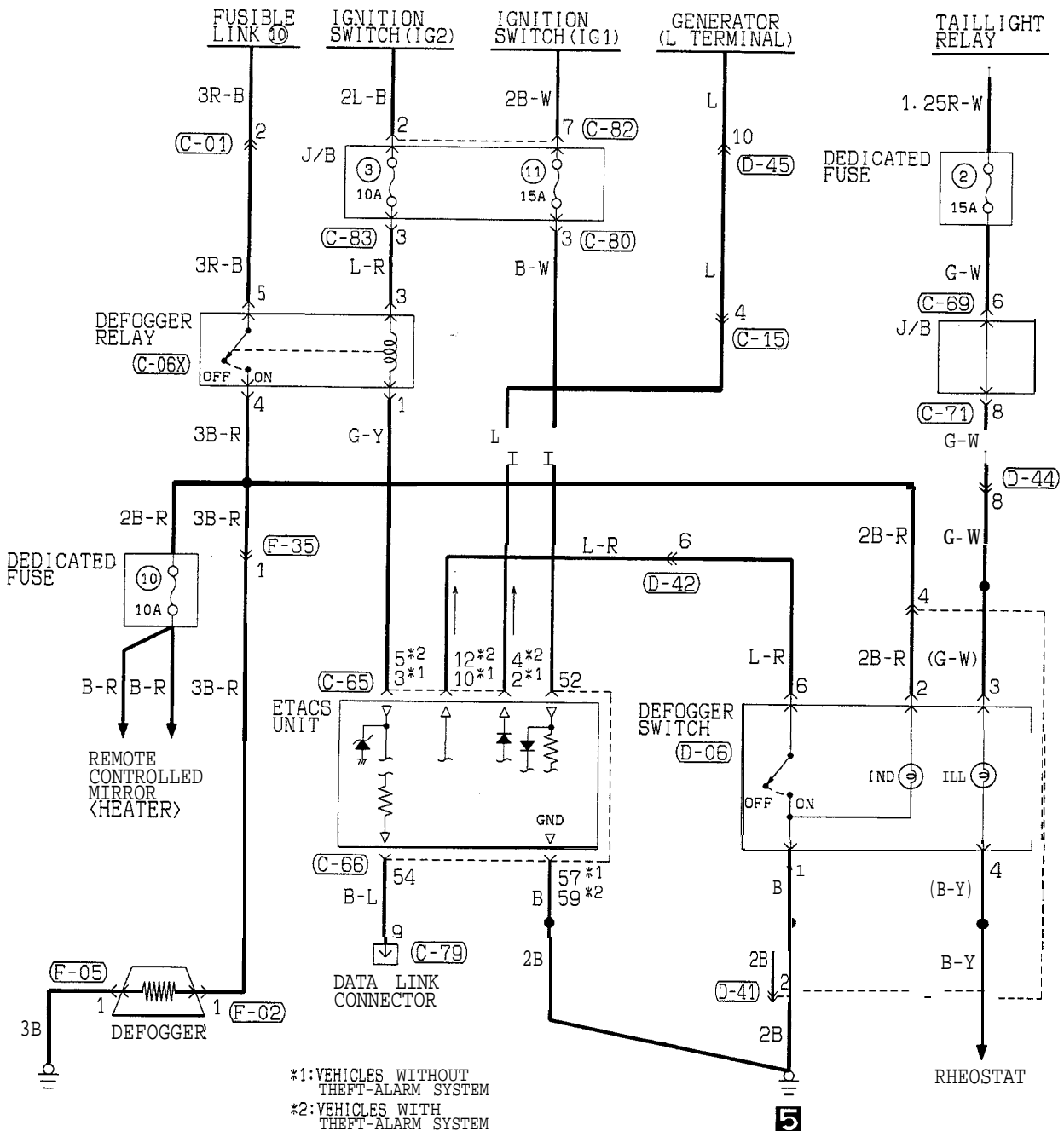

\*1: VEHICLES WITHOUT THEFT-ALARM SYSTEM  
\*2: VEHICLES WITH THEFT-ALARM SYSTEM

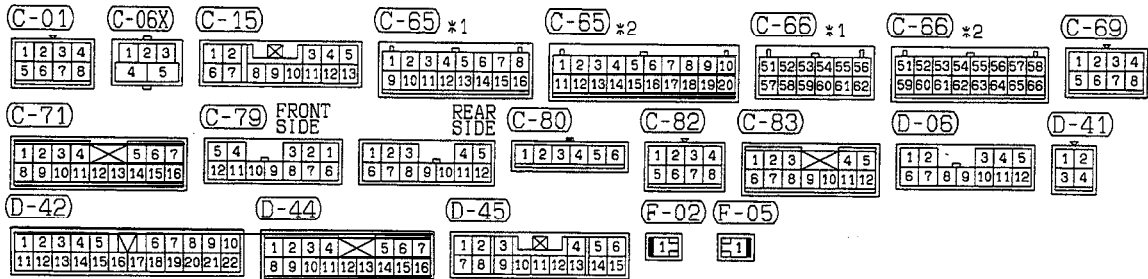

CIRCUIT DIAGRAM <HATCHBACK (FROM 1994 MODELS)>

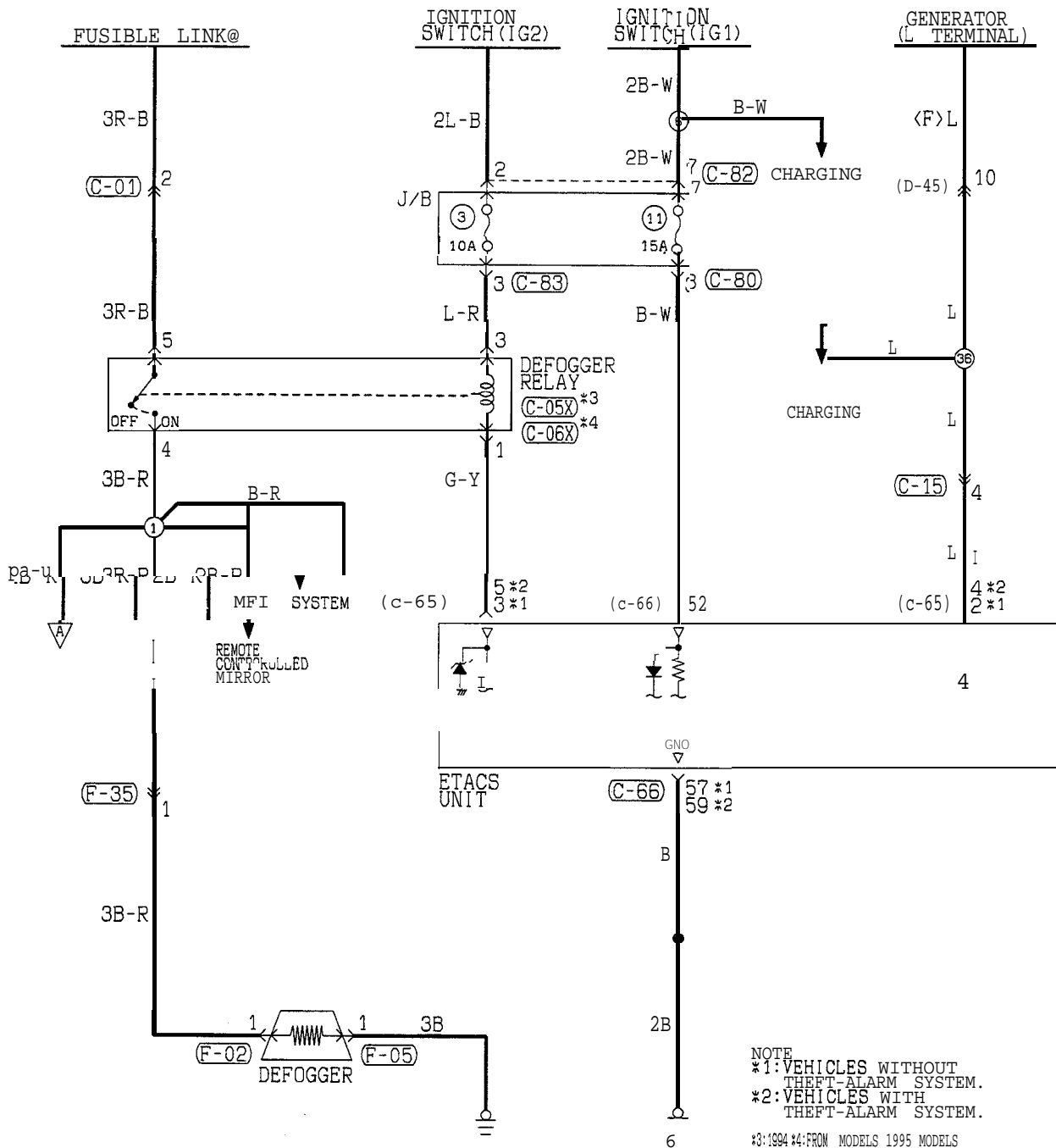

NOTE  
 \*1: VEHICLES WITHOUT THEFT-ALARM SYSTEM.  
 \*2: VEHICLES WITH THEFT-ALARM SYSTEM.

\*3: 1994 \*4: FROM MODELS 1995 MODELS

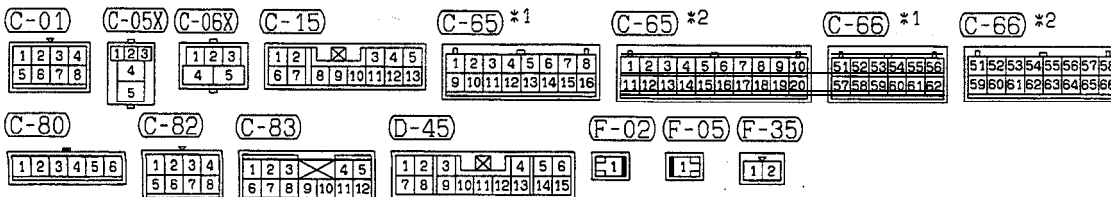

TSB Revision

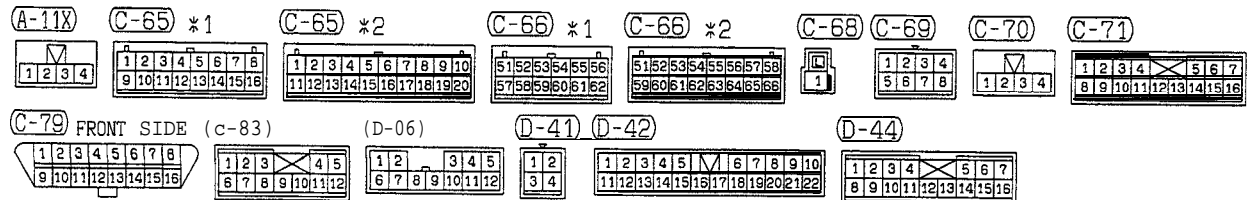
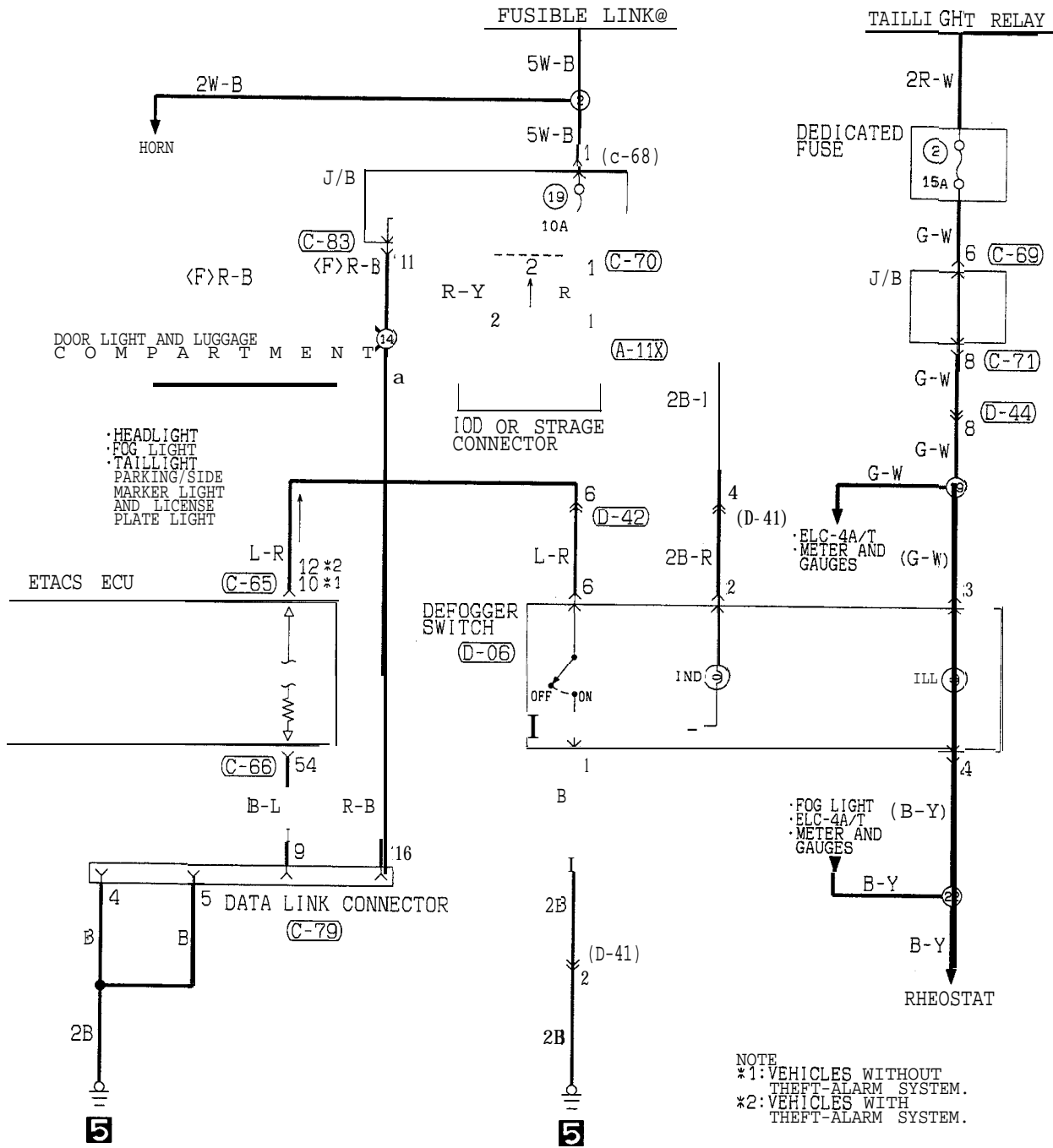

TSB Revision



CIRCUIT DIAGRAM <CONVERTIBLE (1995 MODELS)>

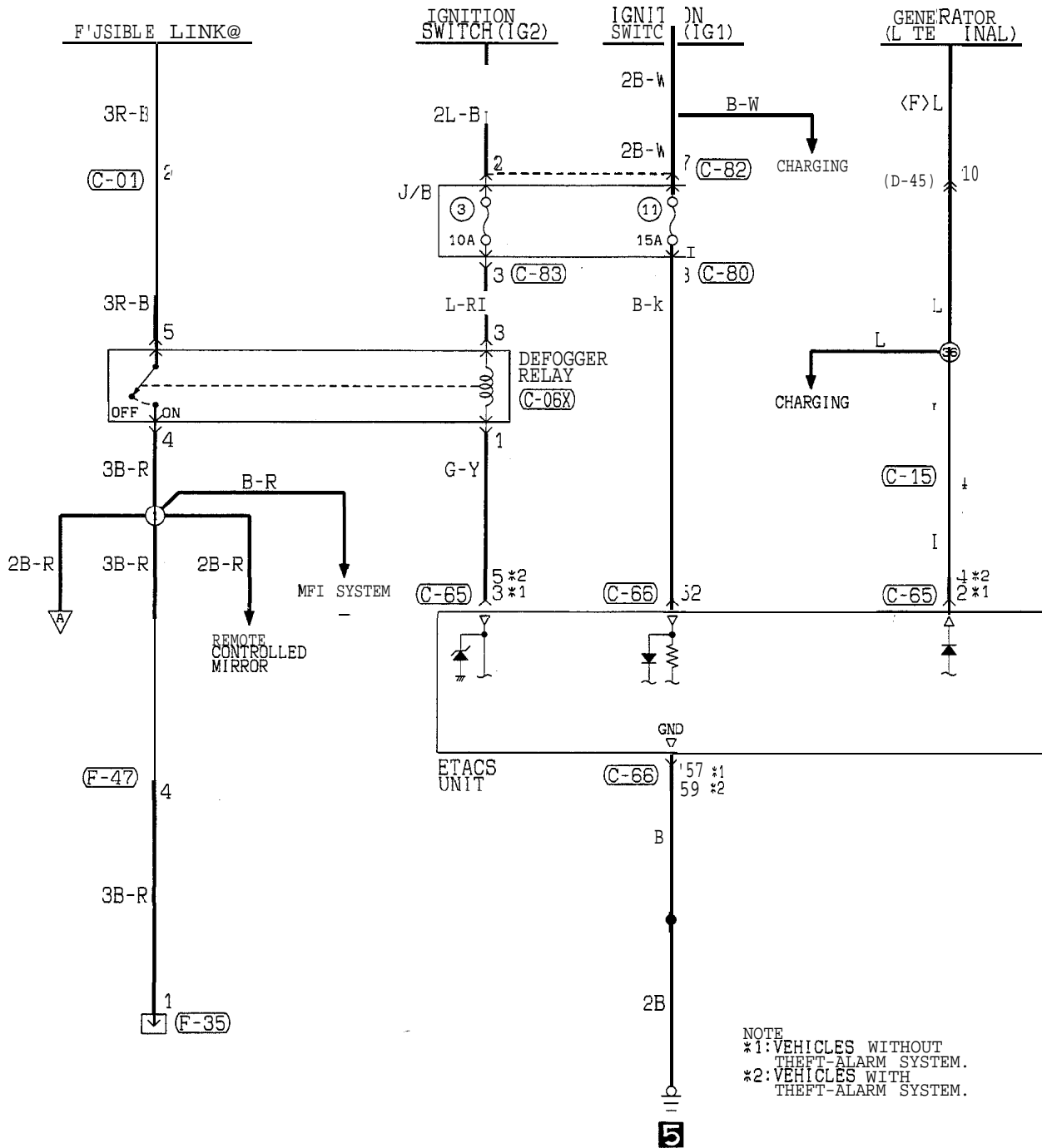

<b>C-01</b> 1 2 3 4 5 6 7 8	<b>C-06X</b> 1 2 3 4 5	<b>C-15</b> 1 2 3 4 5 6 7 8 9 10 11 12 13	<b>C-65</b> *1 1 2 3 4 5 6 7 8 9 10 11 12 13 14 15 16	<b>C-65</b> *2 1 2 3 4 5 6 7 8 9 10 11 12 13 14 15 16 17 18 19 20	<b>C-66</b> *1 51 52 53 54 55 56 57 58 59 60 61 62	<b>C-66</b> *2 51 52 53 54 55 56 57 58 59 60 61 62 63 64 65 66	<b>C-80</b> 1 2 3 4 5 6	
<b>C-82</b> 1 2 3 4 5 6 7 8	<b>C-83</b> 1 2 3 4 5 6 7 8 9 10 11 12	<b>D-45</b> 1 2 3 4 5 6 7 8 9 10 11 12 13 14 15	<b>F-35</b> 1 2	<b>F-47</b> 1 2 3 4				

TSB Revision

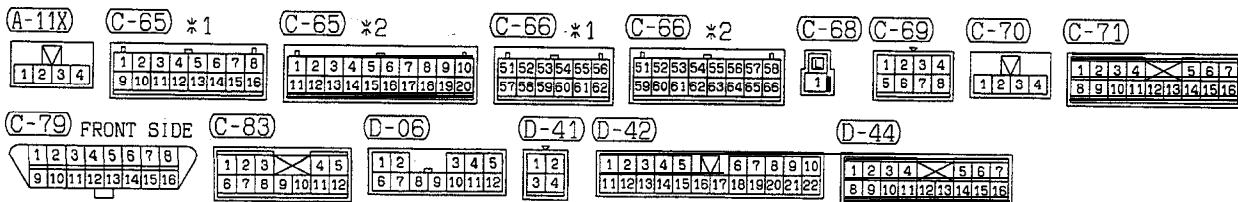
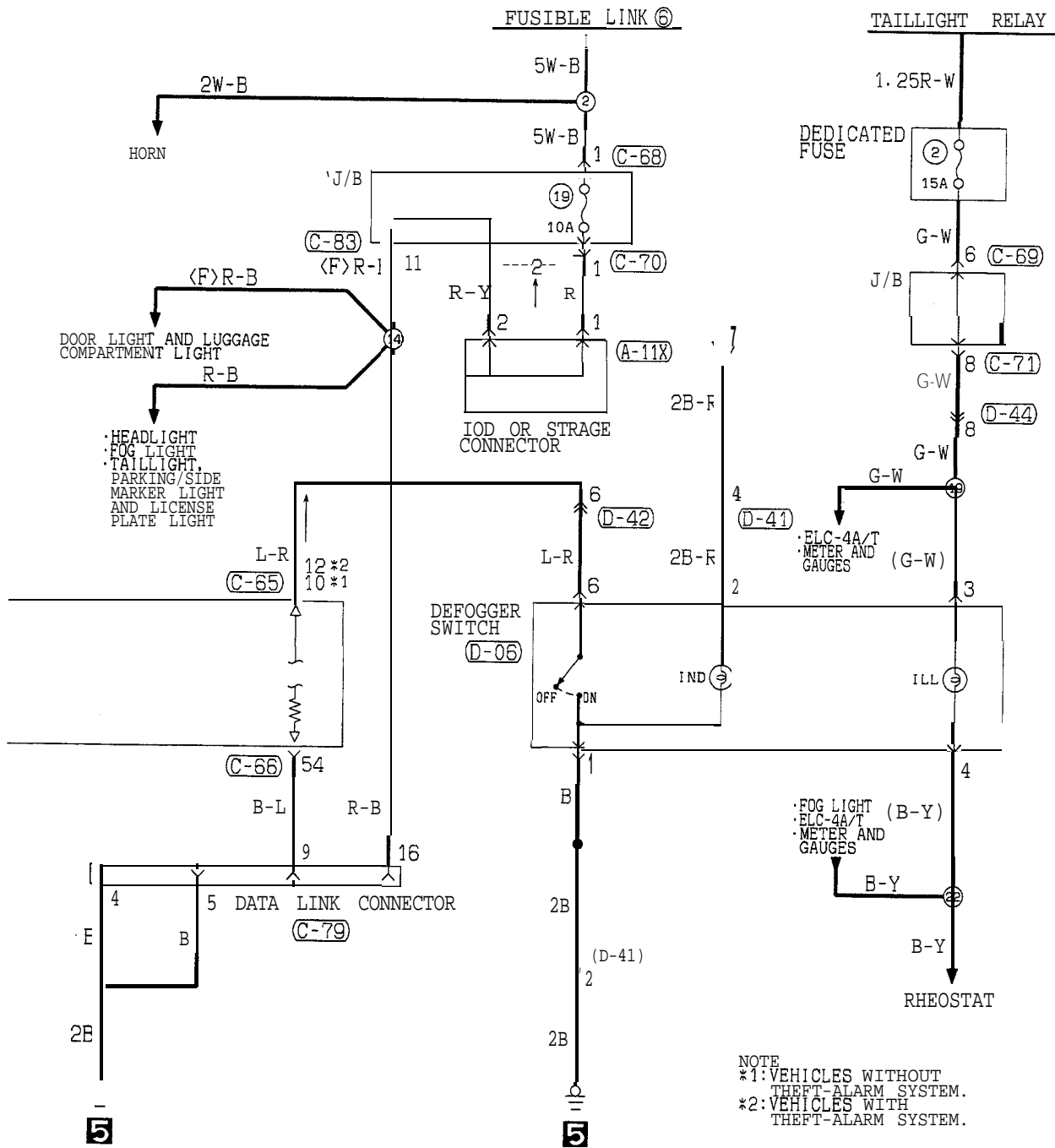

CIRCUIT DIAGRAM <CONVERTIBLE (FROM 1996 MODELS)>

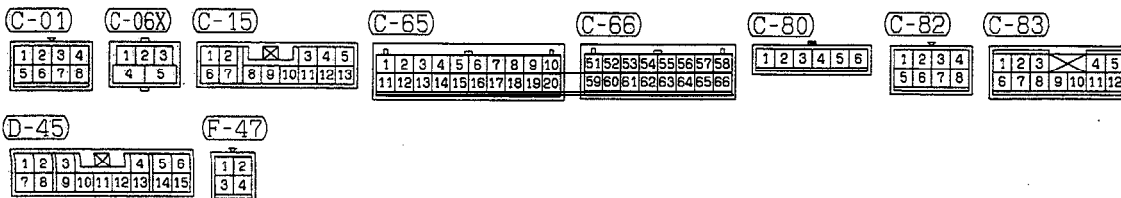
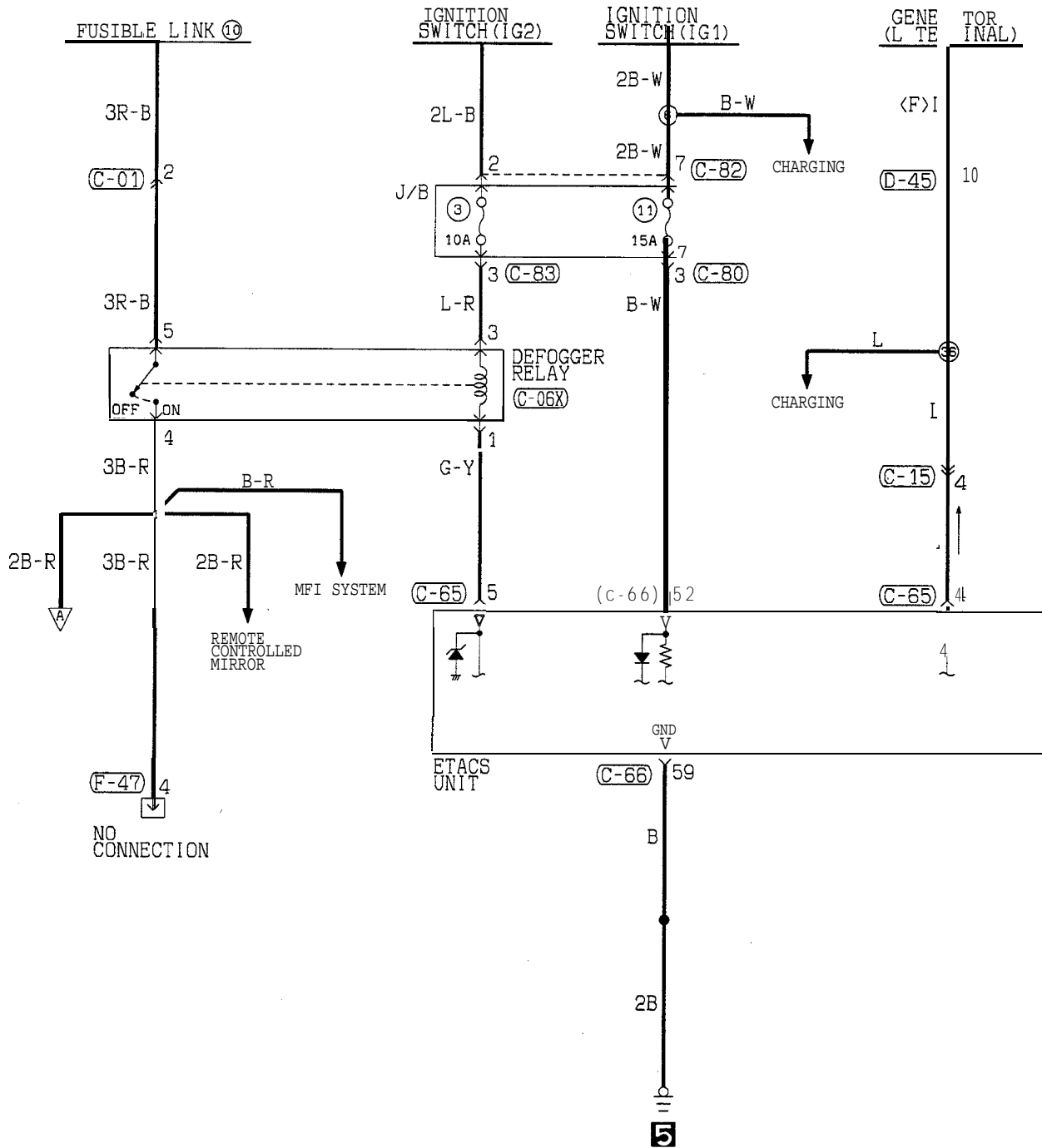

TSB Revision

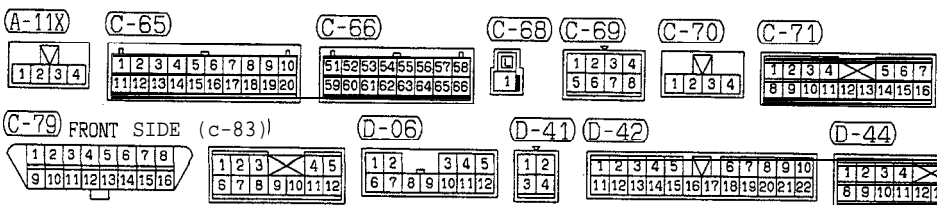
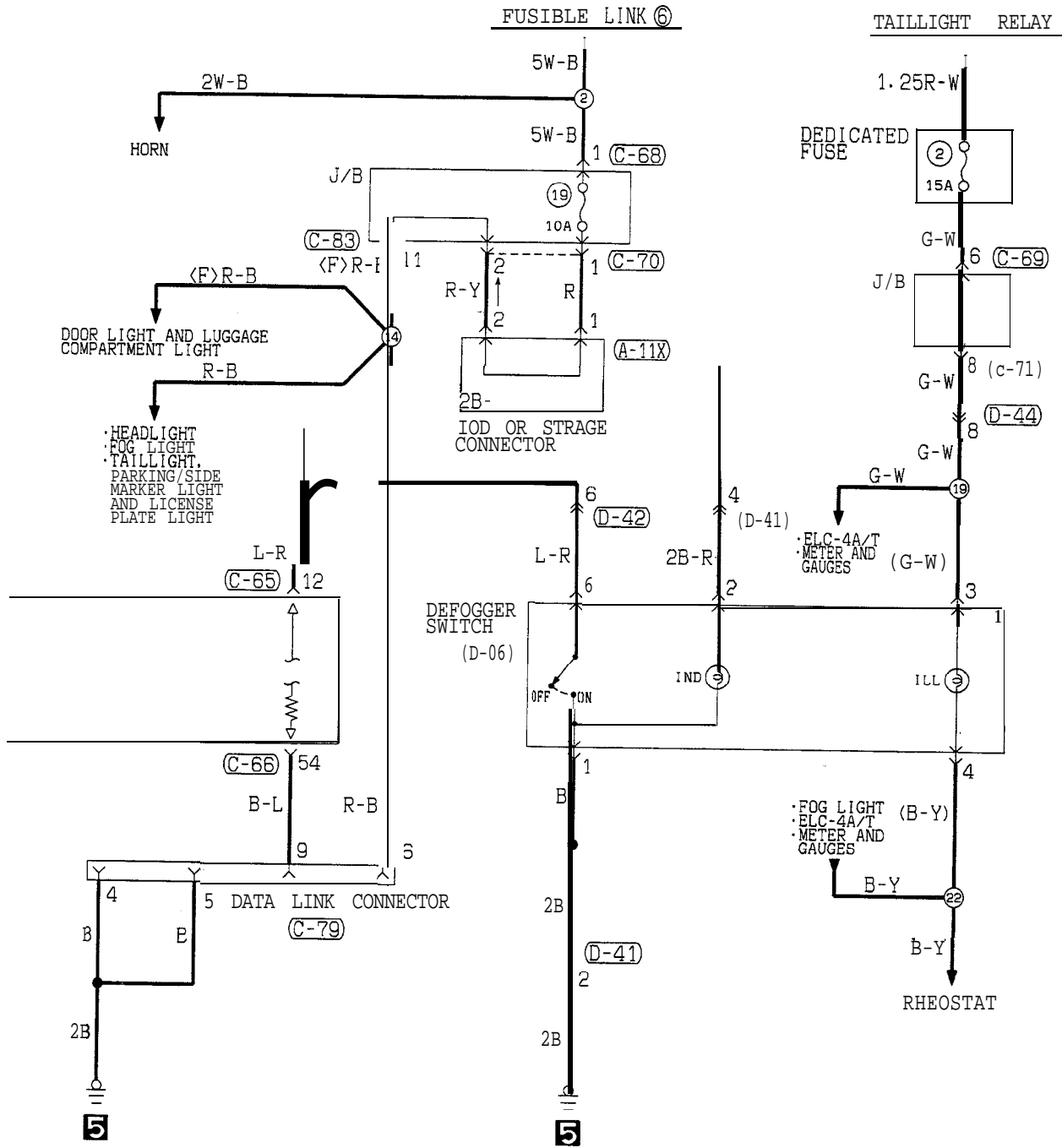

TSB Revision

**OPERATION**

- If the defogger switch is turned to “ON” when the generator is generating electricity (L terminal exceeds 10 V.) with the ignition switch at the “ON” position, the timer circuit in the ETACS unit will be operated to keep the transistor “on” for 11 minutes to close the contact point of the defogger relay. When the defogger relay is “on”, the defogger and mirror heater will be activated. Moreover, the indicator light of the defogger switch is lit to inform that the defogger and mirror heater are activated.
- When 11 minutes have passed, the defogger and mirror heater will stop activating even if the defogger switch is at “ON”. When the defogger and mirror heater are activated (the timer is activated), they will also stop activating even if the defogger switch is set at “ON” again or if the generator stops generating electricity (the terminal is 3.5 V or less.)

**NOTE**

The light automatic shut-off system is valid for the illumination light of the defogger switch. (Refer to P.54-37.)

**TROUBLESHOOTING HINTS**

Phenomenon	Checking method
Mirror heater operates but defogger does not operate.	Check the defogger (Refer to P.54-203.)
Defogger operates but mirror heater does not operate.	Check the dedicated fuse No. (10).
	Check the mirror heater. (Refer to GROUP 51 – Door Mirror.)
Neither defogger nor mirror heater operates.	Check the multi-purpose fuse No. (3).
	Check the defogger relay. (Refer to P.54-204.)
	Check the defogger switch. (Refer to P.54-203.)
	Check the defogger switch input signal. (Refer to P.54-202.)
	Check the ignition switch input signal. (Refer to P.54-202.)
	Check the generator. (Refer to GROUP 16 – On-vehicle Service.)
Illumination light of defogger switch does not come on or is dim.	Check the illumination light bulb.
	Check the rheostat. (Refer to P.54-110.)

**NOTE**

For the troubleshooting hints of the automatic light shut-OFF system, refer to P.54-38.

**COMPONENT LOCATION**

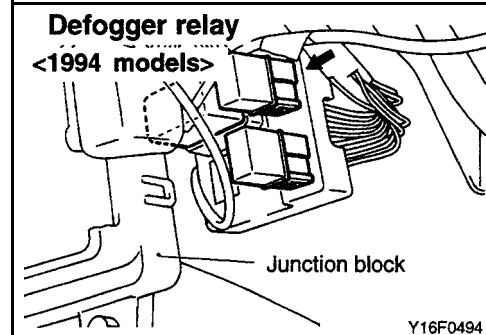
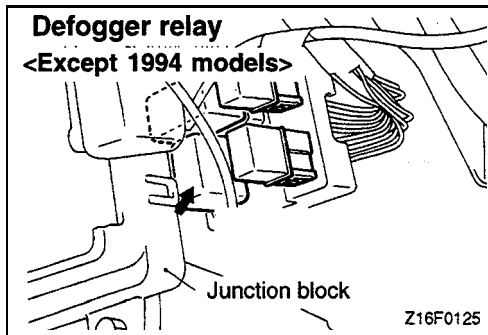
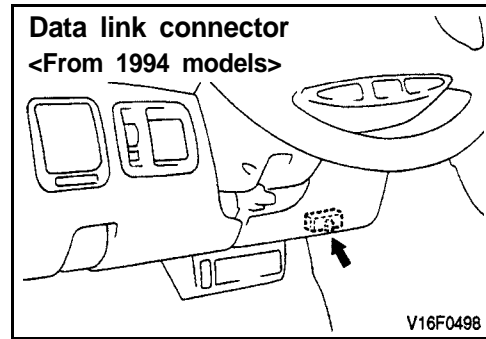
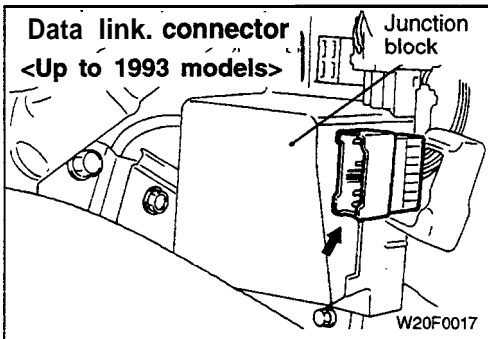

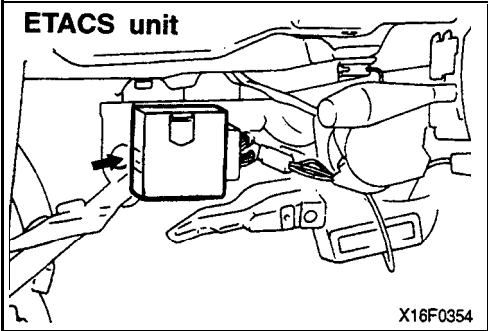

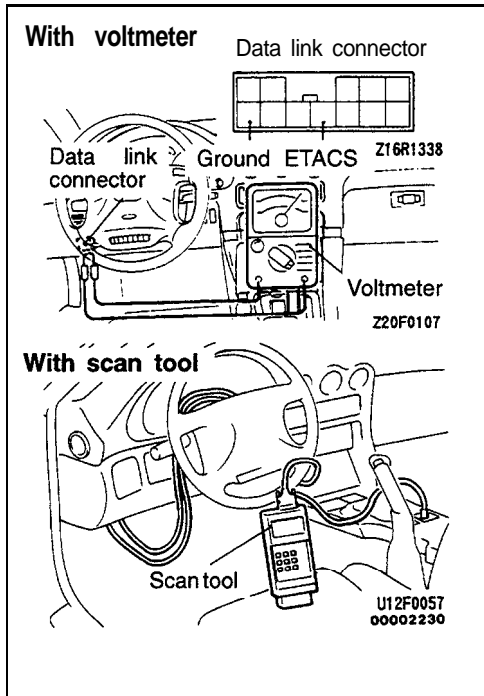
**INPUT SIGNAL****<Up to 1993 models>****When using the scan tool (MUT) or voltmeter**

Using the scan tool or voltmeter, check whether or not the input signals from each switch are being input to the ETACS unit.

- (1) Connect the scan tool to the data link connector located at the right side of the junction block or connect the voltmeter between the ETACS terminal and the ground terminal.
- (2) Check if the buzzer of the scan tool sounds or the needle of the voltmeter moves when each switch is operated. If the buzzer sounds or the needle moves, the input signals are being input to the ETACS unit, so that switch can be considered to be functioning normally. If not, the switch or switch input circuit is faulty. Check the switch and the switch input circuit.

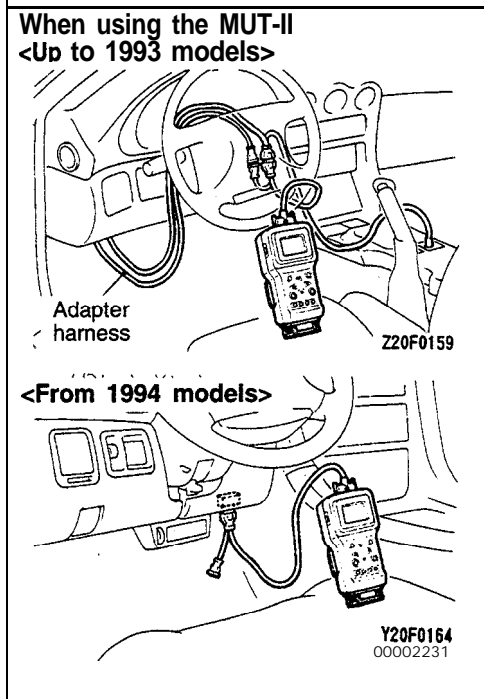
**<All models>****When using the scan tool (MUT-II)**

- (1) Connect the scan tool to the data link connector. When connecting the scan tool to a vehicle up to 1993 models, use the adapter harness supplied together.

**Caution**

**Turn off the ignition switch beforehand whenever the scan tool is connected or disconnected.**

- (2) If the scan tool makes a peep sound when each switch is operated (turned ON/OFF), the input signal to ECU is normally sent from the switch circuit system.

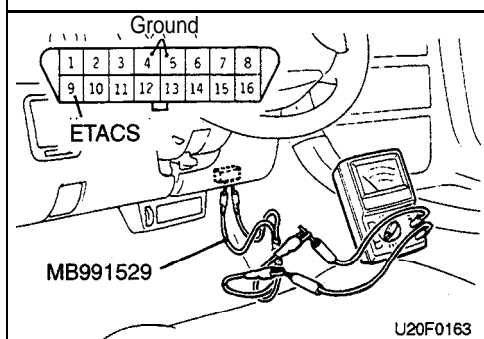
**<From 1994 models>****When using the voltmeter**

- (1) Connect a voltmeter to the ETACS terminal and the ground terminal of the data link connector using the special tool.
- (2) If the voltmeter pointer deflects once when each switch is operated (turned ON/OFF), the input signal to ECU is normally sent from the switch circuit system.

**ON-VEHICLE SERVICE**

**THE PRINTED-HEATER LINES CHECK**

- (1) Run engine at 2,000 rpm. Check heater element with battery at full.
- (2) Turn ON rear window defogger switch. Measure heater element voltage with circuit tester at rear window glass center A.
- (3) If 12 V is indicated at A, there is a break in the negative terminals from A.  
Move test bar slowly to negative terminal to detect where voltage changes suddenly (0 V).
- (4) If 0 V is indicated at A, there is a break in the positive terminals from A. Detect where the voltage changes suddenly (12 V) with the same method described.

**THE PRINTED-HEATER LINES REPAIR**

**REQUIRED MATERIALS**

- Thinner
- Tape
- Conductive paint
- Lead-free gasoline
- Fine brush

- (1) Clean disconnected area with lead-free gasoline. Tape along both sides of heater element.
- (2) Mix conductive paint thoroughly. Thin the required amount of paint in a separate container with a small amount of thinner and paint break three times at 15 minute intervals.
- (3) Remove tape and leave for a while before use (circuit complete).
- (4) When completely dry (after 24 hours) finish exterior with a knife.

**Caution**

Clean glass with a soft cloth (dry or damp) along defogger heater element.

**REAR WINDOW DEFOGGER SWITCH**

- (1) Remove rear window defogger switch from the meter bezel. (Refer to P.54-109.)
- (2) Operate the switch and check the continuity between the terminals.

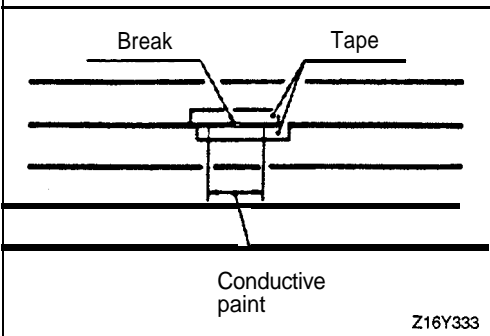
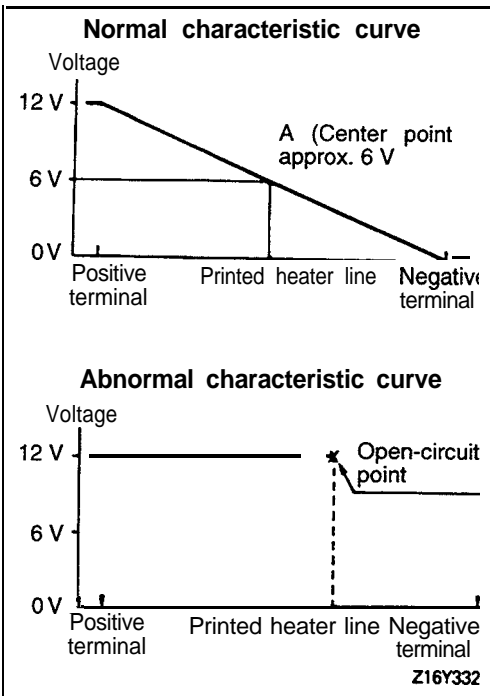

Switch position	Terminal No.					
	1	2	3	4	5	6
OFF						
ON	○	○	○	○		○
		IND		ILL		

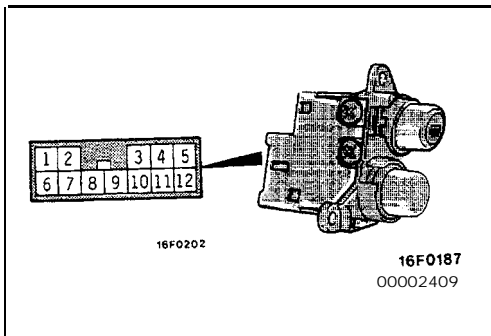



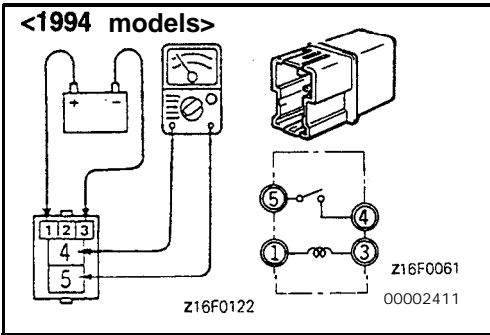
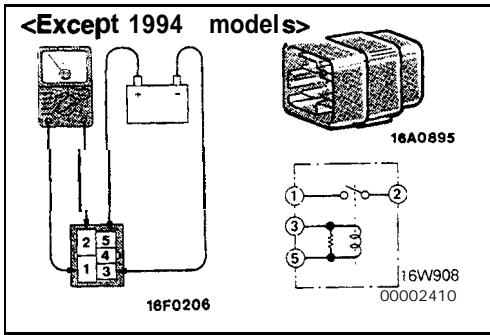

## DEFOGGER RELAY

### INSPECTION

**<Except 1994 models>**

Connect battery power source to terminal 5. Check circuit between terminals with terminal 3 grounded.





Power is supplied	1-2 terminals	Continuity
Power is not supplied	1-2 terminals	No continuity
	3-5 terminals	Continuity

**<1994 models>**

Connect battery power source to terminal 1. Check circuit between terminals with terminal 3 grounded.

Power is supplied	4-5 terminals	Continuity
Power is not supplied	4-5 terminals	No continuity
	1-3 terminals	Continuity

**THEFT-ALARM SYSTEM****SPECIAL TOOLS**

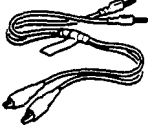
Tool	Tool number and name	Supersession	Application
	MB991 341 Scan tool (Multi-use tester <MUT>)	MB991 341 C	Up to 1993 models Checking the theft-alarm system
	ROM Pack (For the number, refer to GROUP 00 – Precautions Before Service.)		
	MB991 502 Scan tool (MUT-II)	MB991 502	All models Checking the theft-alarm system
 Z16X0607	ROM pack		
	MB991 529 Diagnostic trouble code check harness	MB991 529	From 1994 models Checking the theft-alarm system using a voltmeter

TROUBLESHOOTING

(UP TO 1993 MODELS)

CIRCUIT DIAGRAM

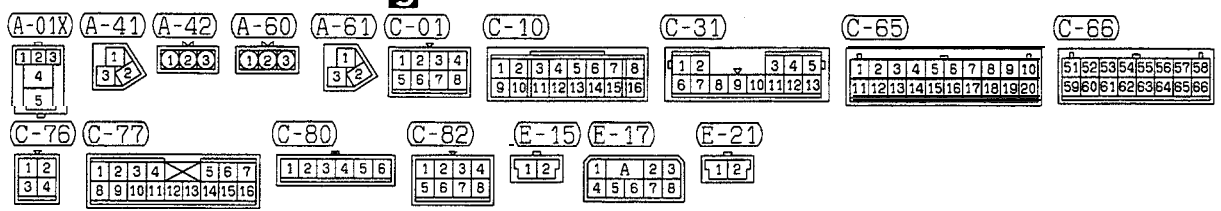
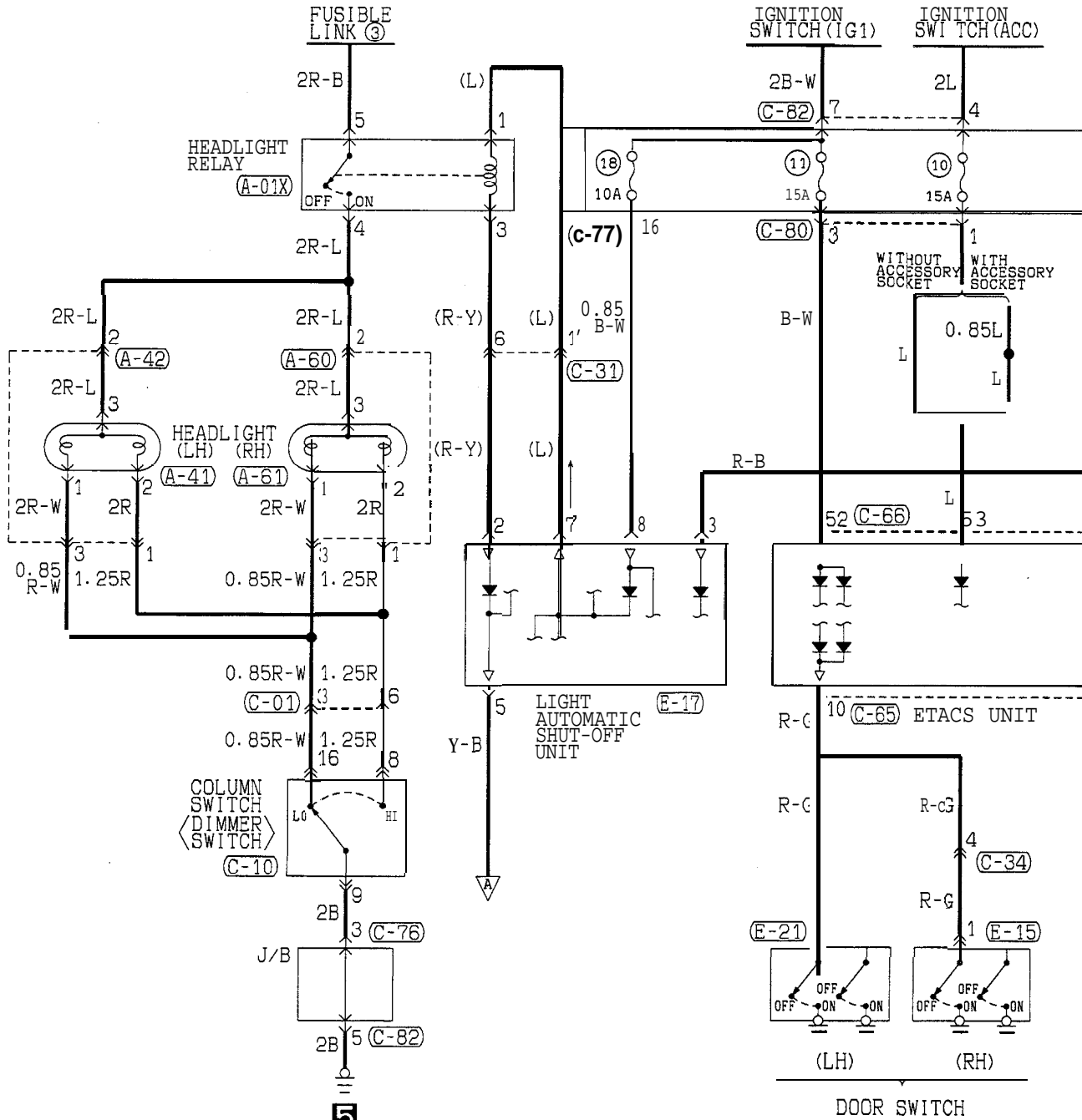

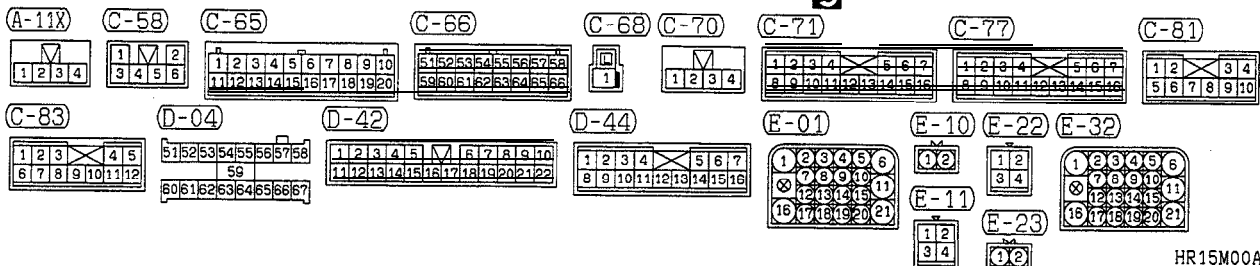
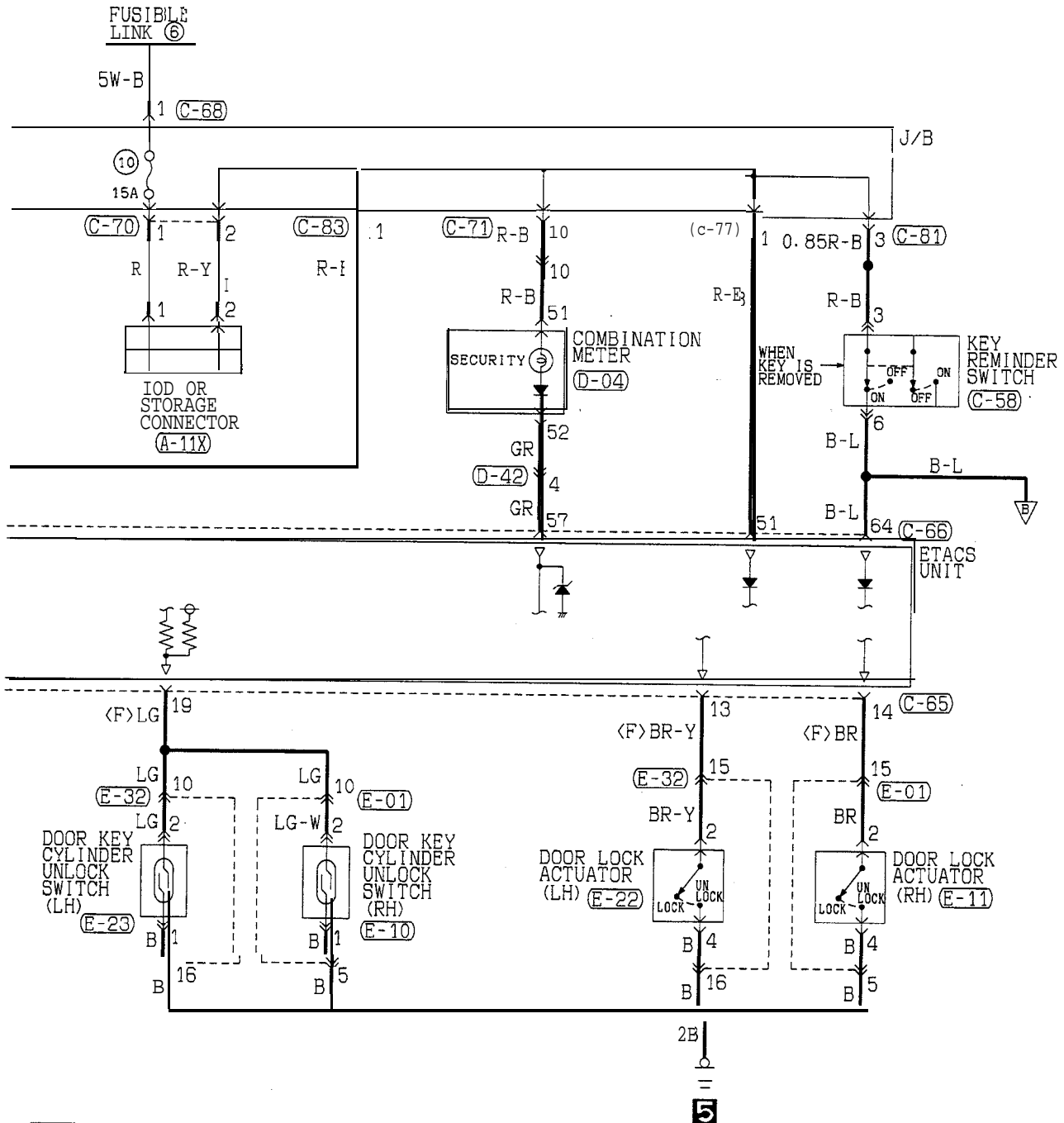

HR15M00AB

TSB Revision

CIRCUIT DIAGRAM (CONTINUED)

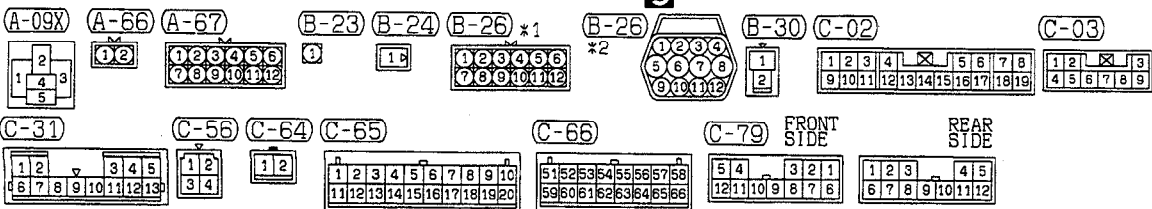
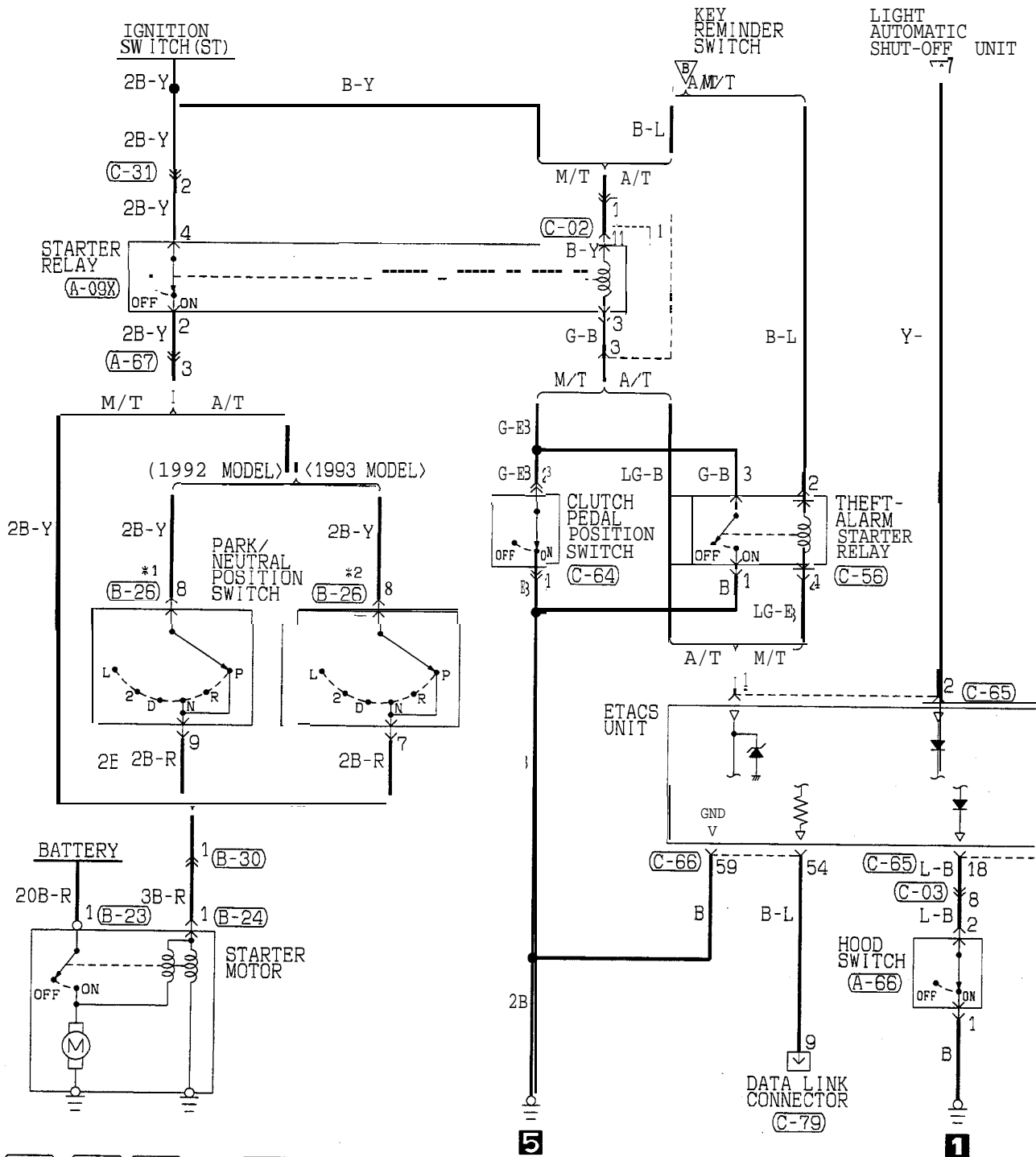

TSB Revision

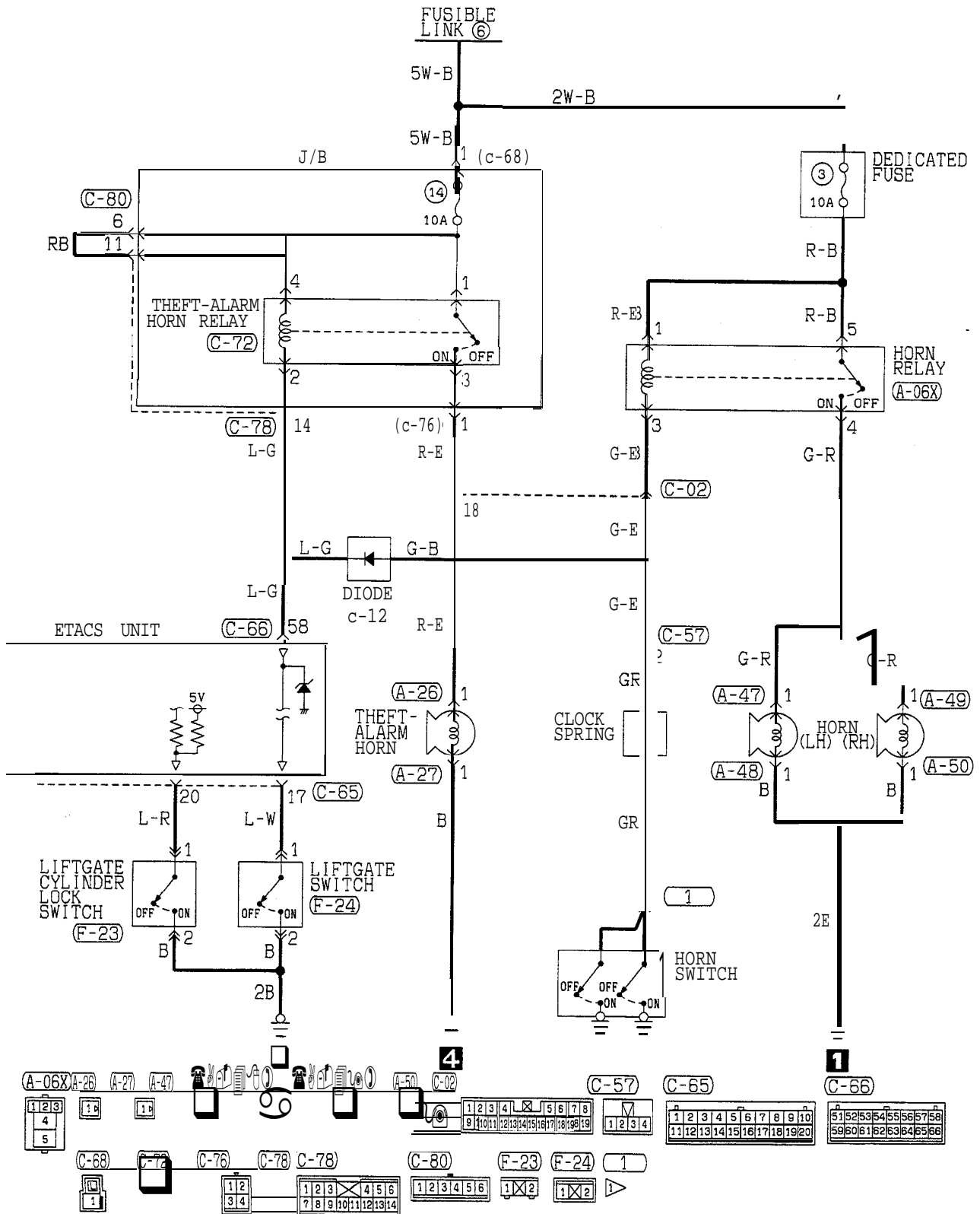

HR15M00BB

TSB Revision

CIRCUIT DIAGRAM <HATCHBACK (FROM 1994 MODELS)>

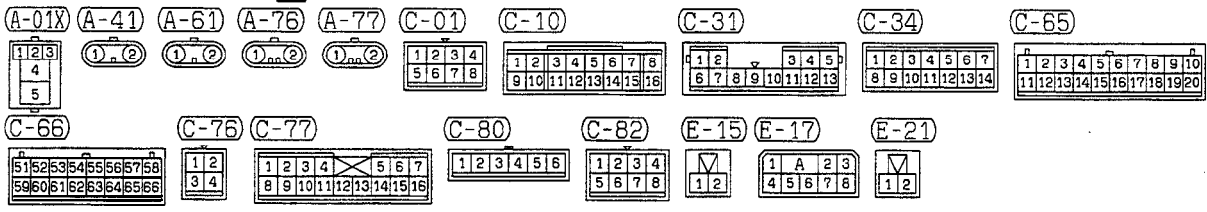
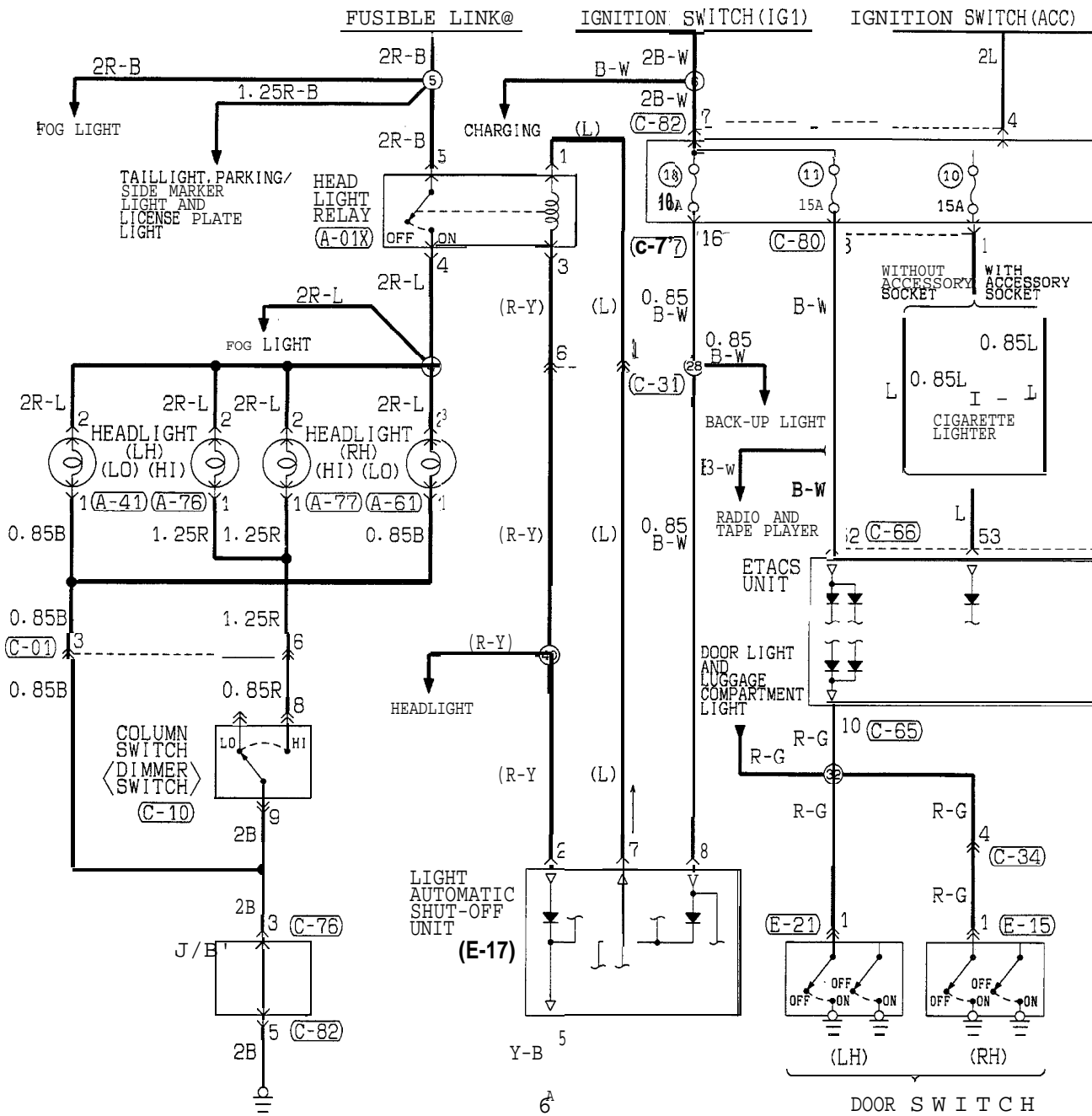

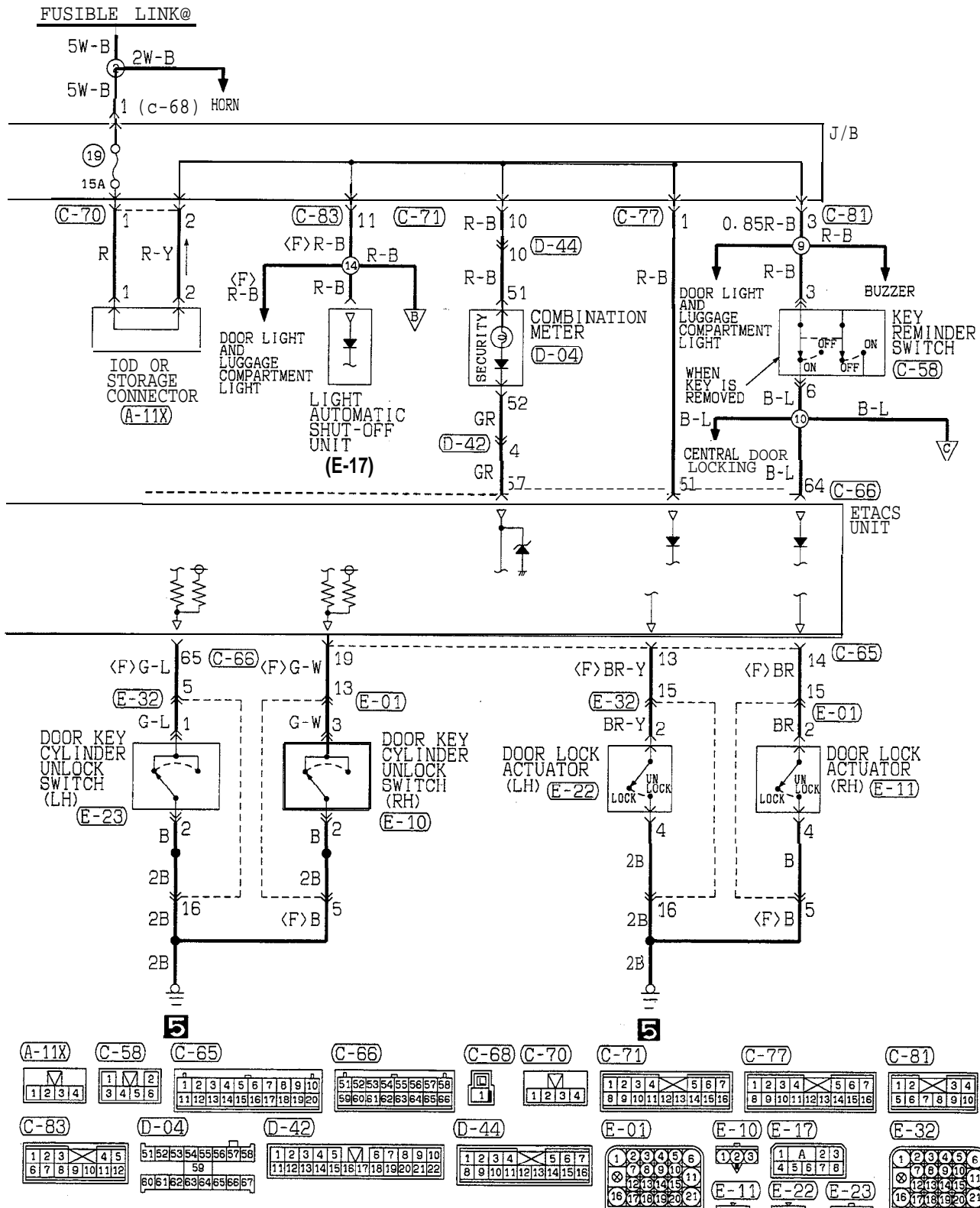

HR15M01AB

TSB Revision



CIRCUIT DIAGRAM (CONTINUED)

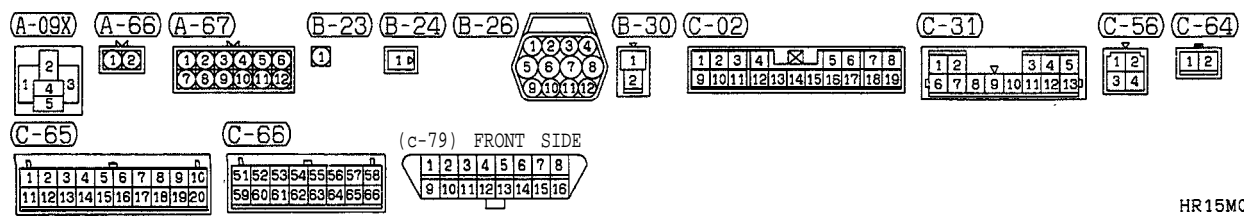
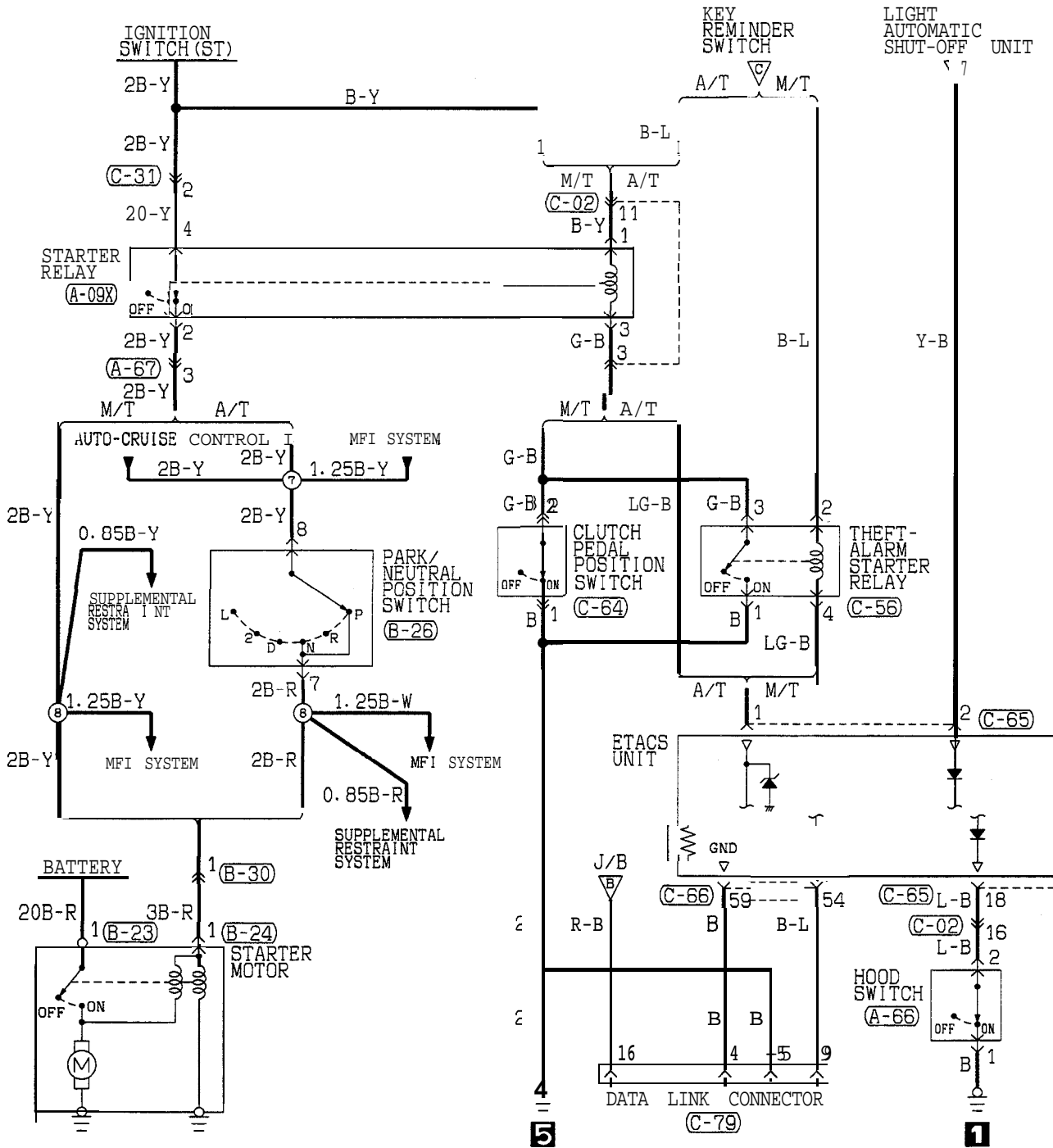

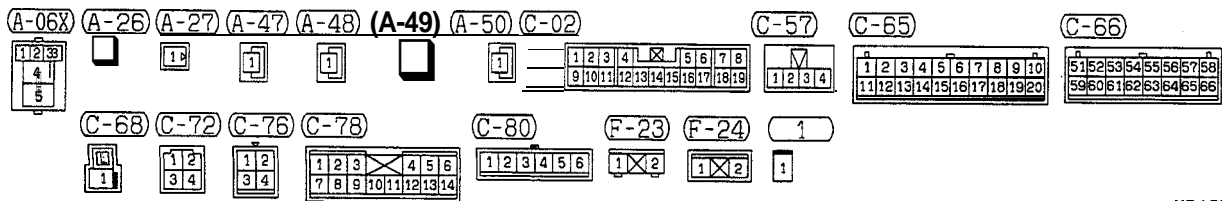
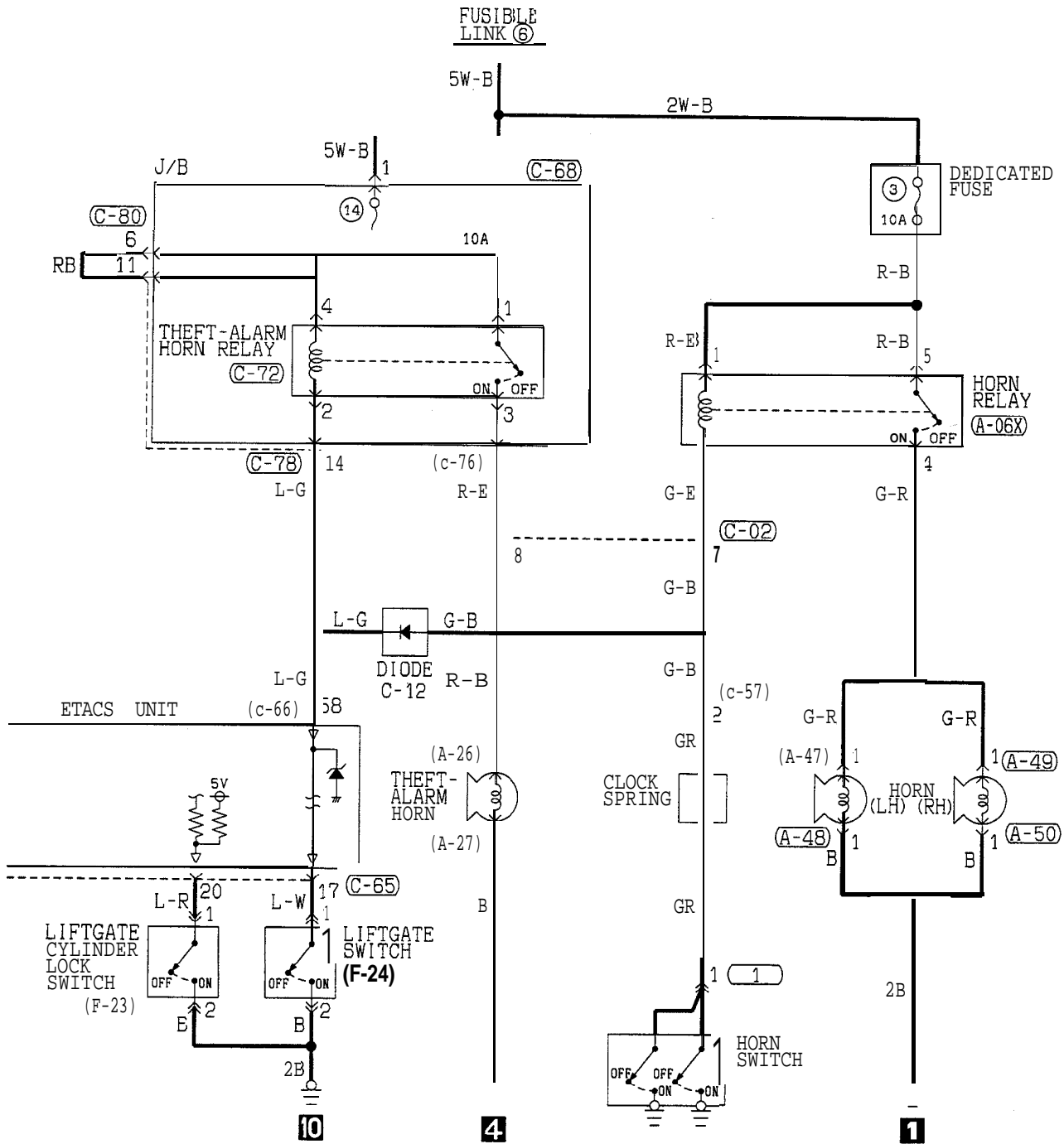

CIRCUIT DIAGRAM <CONVERTIBLE (FROM 1995 MODELS)>

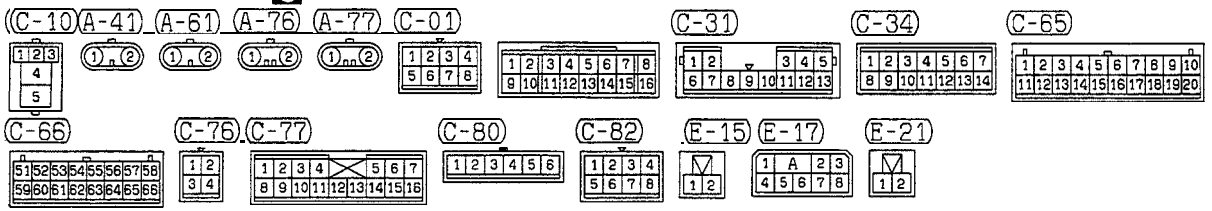
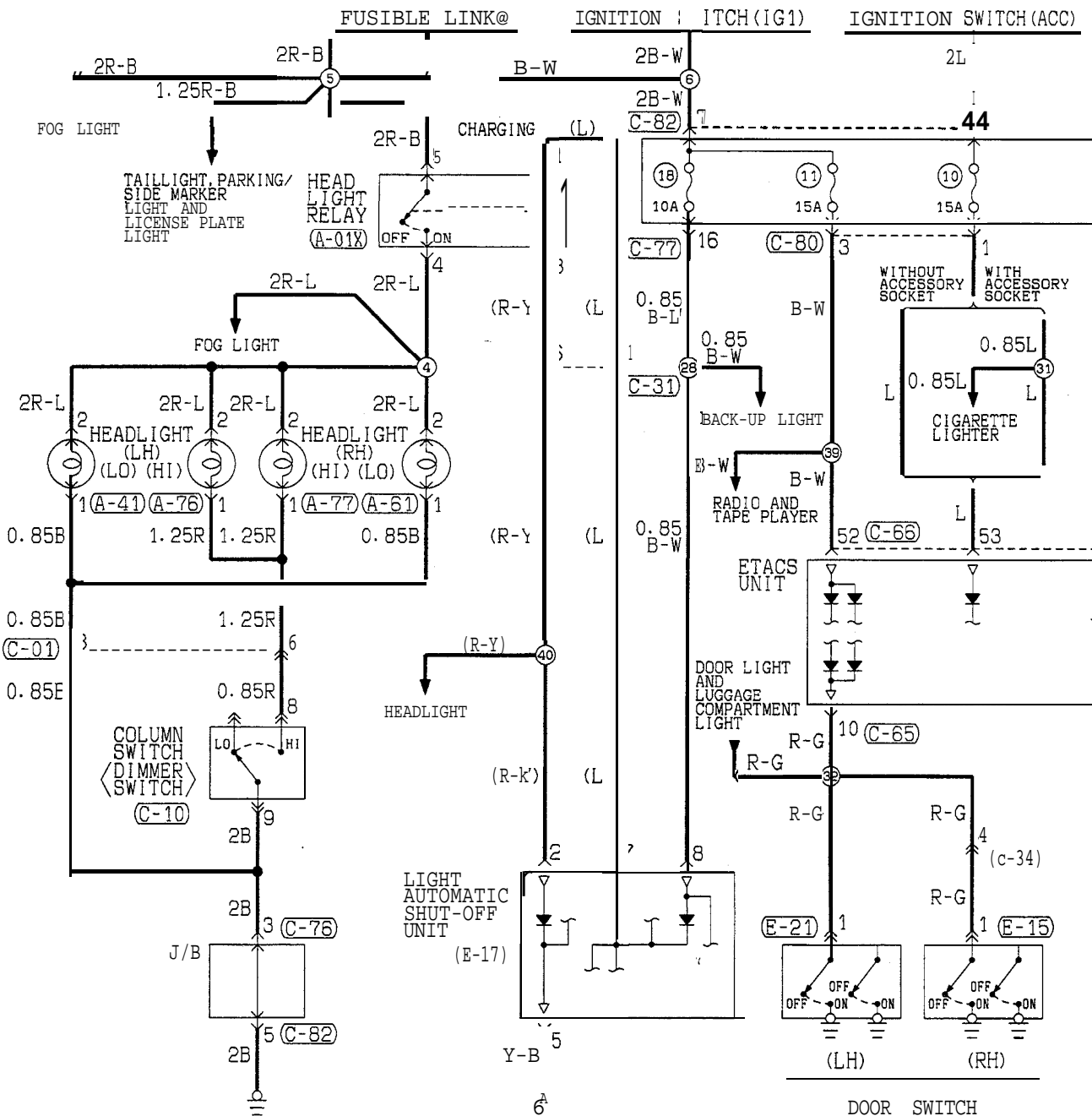

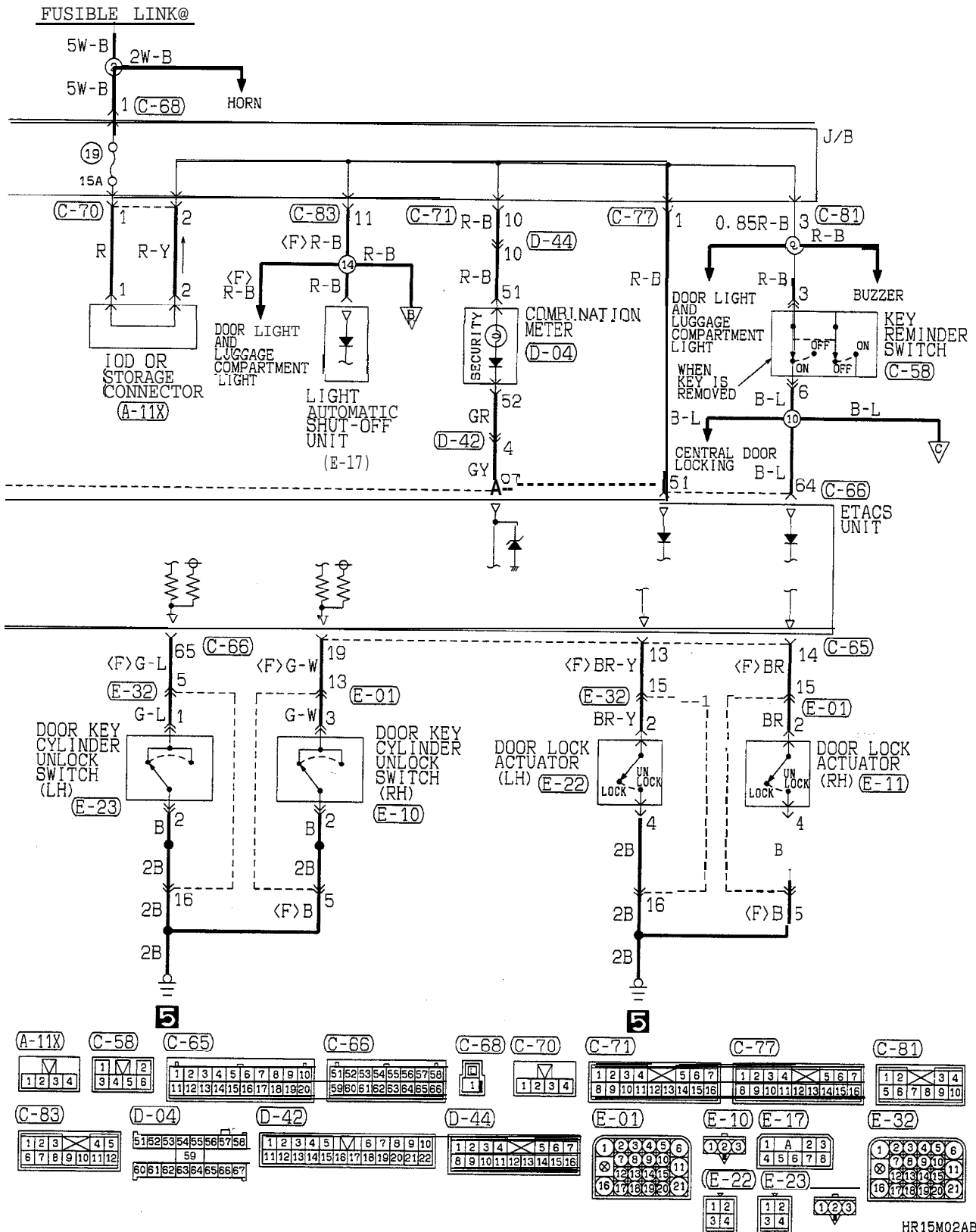

CIRCUIT DIAGRAM (CONTINUED)

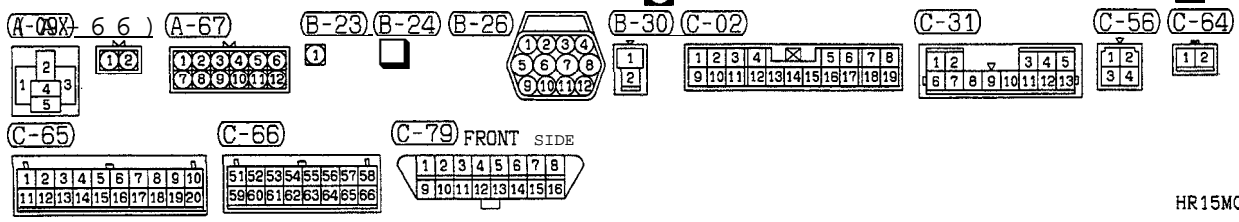
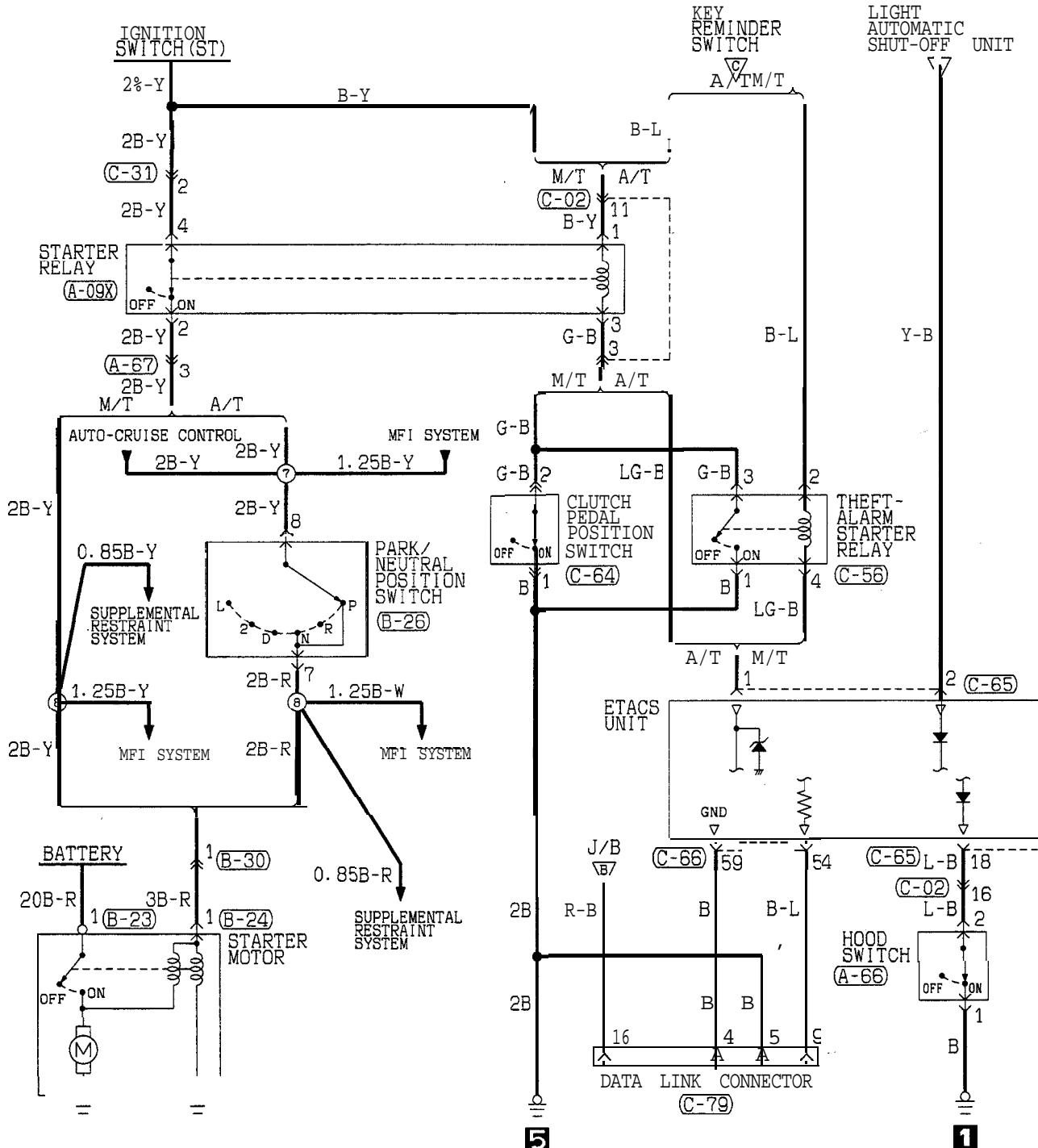

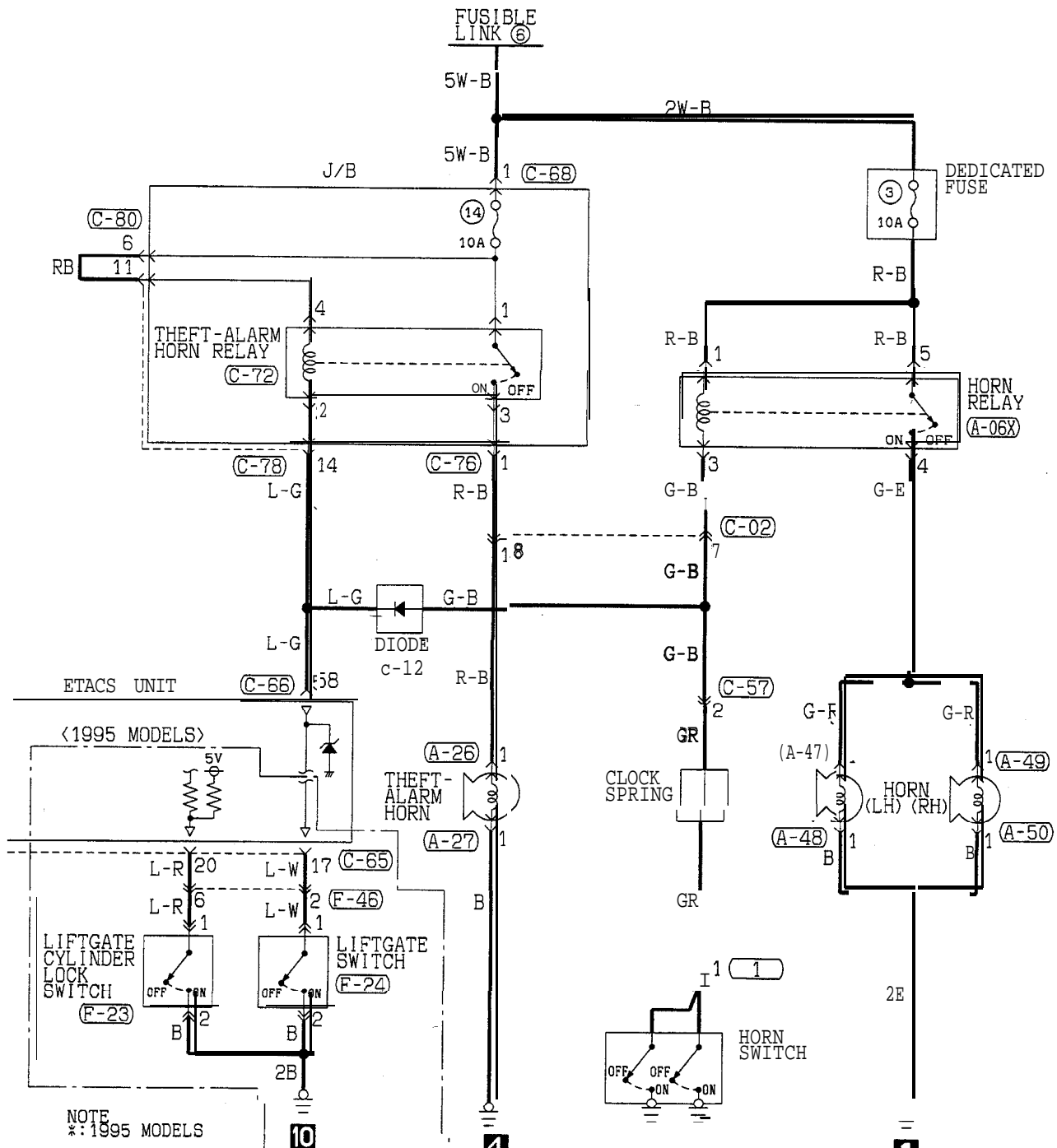

NOTE  
\*: 1995 MODELS

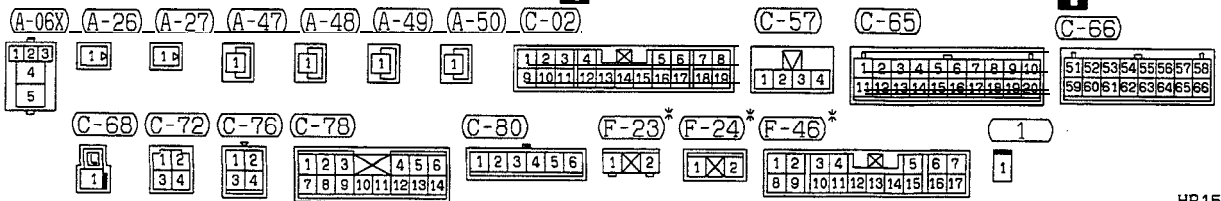

HR15M02BB

TSB Revision

COMPONENT LOCATION

Name	Symbol	Name	Symbol
Data link connector <From 1994 models>	G	Horn relay	A
Data link connector <Up to 1993 models>	F	Light automatic shut-off unit	H
Diode	D	Starter relay	A
ETACS unit	C	Theft-alarm horn relay	B
Headlight relay	A	Theft-alarm starter relay	E

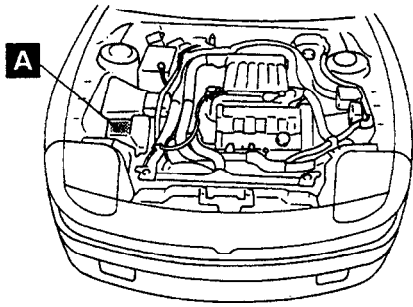

16F0257

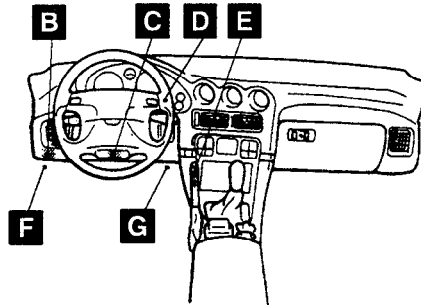

19F0134

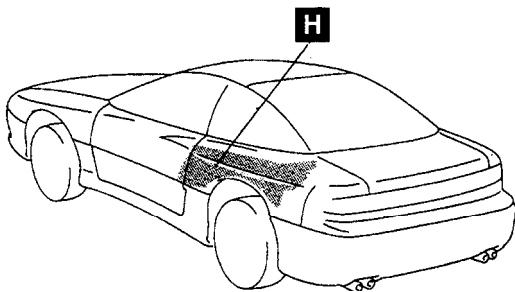

16F0268  
00002412

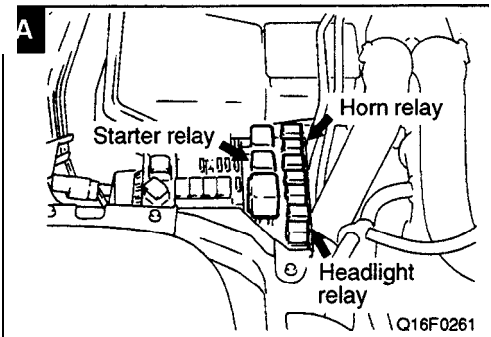

Q16F0261

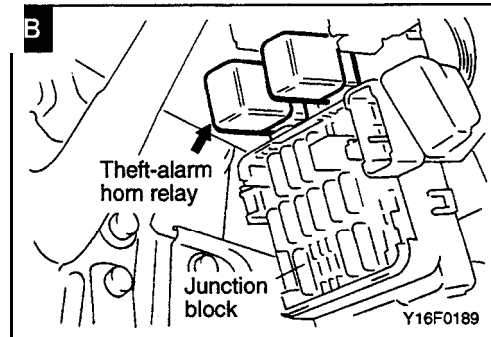

Y16F0189

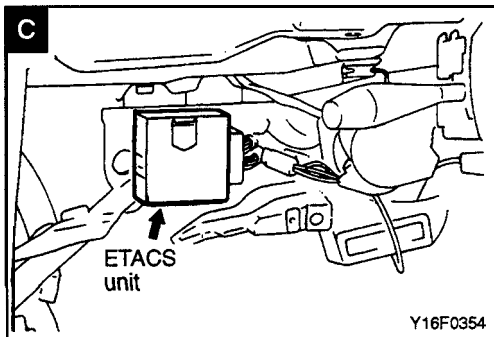

Y16F0354

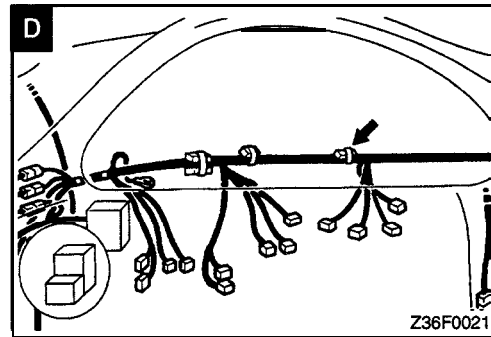

Z36F0021

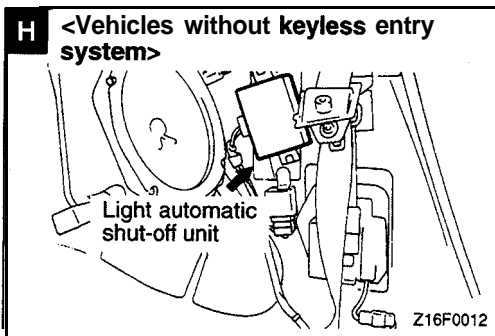
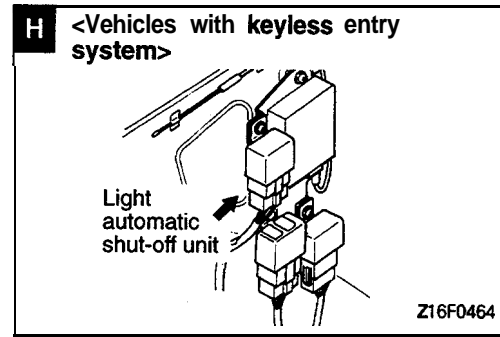
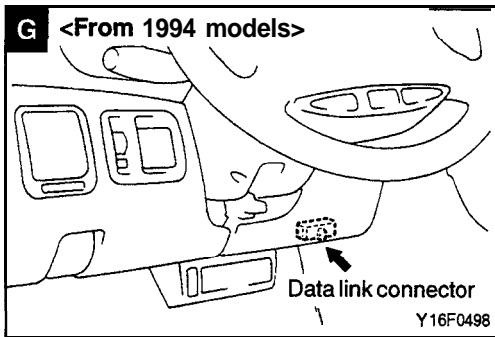
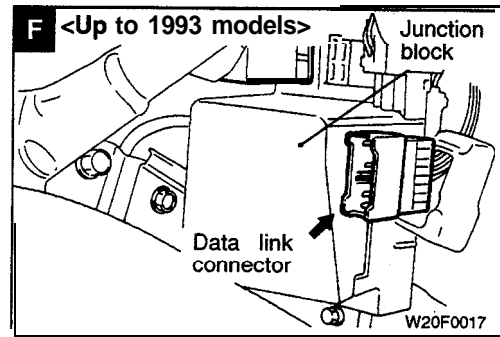
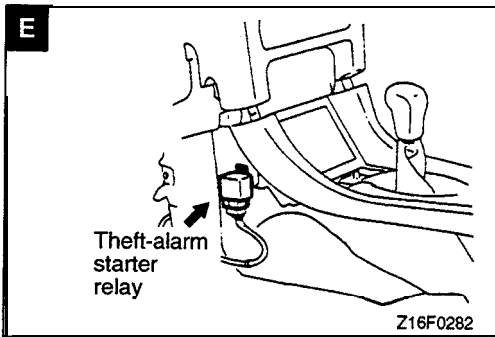



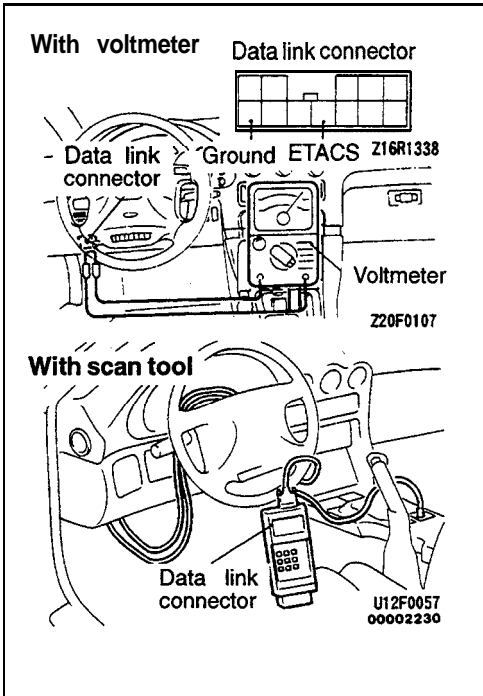

**TROUBLESHOOTING GUIDE**

**CHECKING THE INPUT**

**<Up to 1993 models>**

**When using the scan tool (MUT) or voltmeter**

1. Connect a voltmeter between terminal for ETACS and terminal for ground, or connect the scan tool to the data link connector.

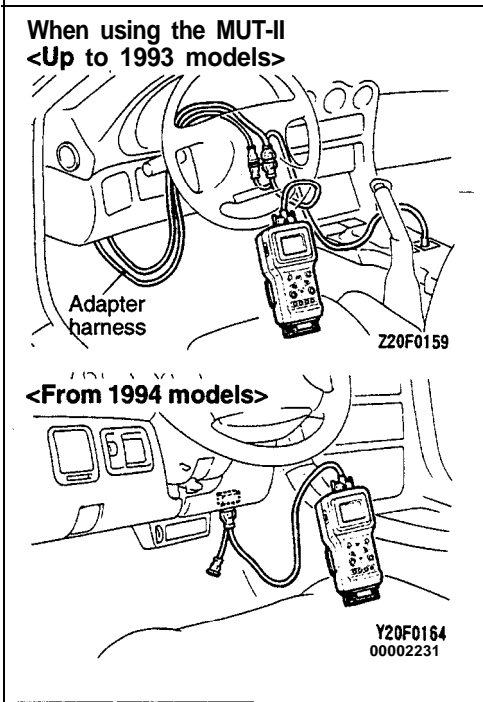

**<All models>**

**When using the scan tool (MUT-II)**

1. Connect the scan tool to the data link connector. When connecting the scan tool to a vehicle up to 1993 models, use the adapter harness supplied together.

**Caution**

**Turn off the ignition switch beforehand whenever the scan tool is connected or disconnected.**

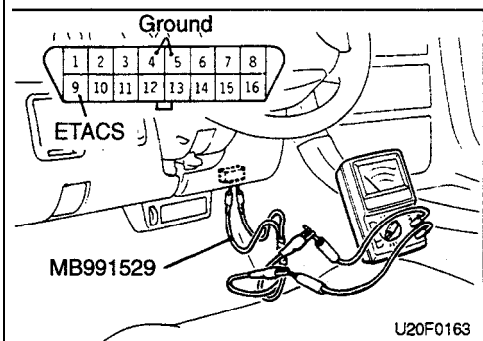

**<From 1994 models>**

**When using the voltmeter**

1. Connect a voltmeter to the ETACS terminal and the ground terminal of the data link connector using the special tool.

2. Make sure that when the following switches are turned on, the output shown in the illustration is delivered. (Only those switches which are related to the theft-alarm system are listed here.)

- Driver and front passenger door switches
- Headlight switch
- Driver and front passenger door lock switches
- Passing light switch
- Pop-up switch (up to 1993 models)
- Hood switch
- Liftgate switch
- Door key cylinder switch
- Liftgate switch

If there is no output of a voltage pattern at all, check for a malfunction of that switch or for damaged or disconnected wiring.

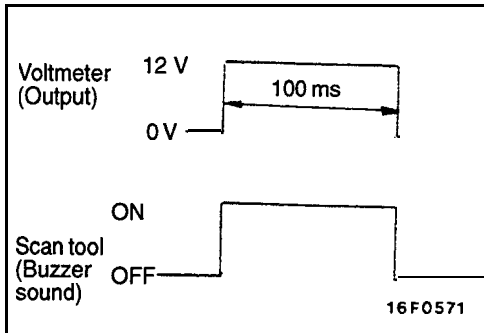

## TROUBLESHOOTING QUICK-REFERENCE TABLE

For information concerning the locations of electrical components, refer to GENERAL-Theft-alarm System Circuit.

## 1. ARMING / DISARMING RELATIONSHIP

Trouble symptom	Cause	Check method	Remedy
The system is not armed (The SECURITY light doesn't illuminate, and the alarm doesn't function.) (The central door locking system functions normally. If the central locking system does not function normally, refer to GROUP 42.)	Damaged or disconnected wiring of ECU power supply circuit	Check by using check chart P.54-224.	Replace the fusible link No. (6) or the fuse No. (19). Repair the harness.
	Damaged or disconnected wiring of door switch input circuit	Check by using check chart P.54-225.	Repair the harness or replace the door switch.
The arming procedures are followed, but the SECURITY light does not illuminate. (There is an alarm, however, when an alarm test is conducted after about 20 seconds have passed.)	Damaged or disconnected wiring of SECURITY light activation circuit.	Check by using check chart P.54-229.	Replace the fusible link No. (6) or the fuse No. (19). Repair the harness.
	Blown SECURITY light bulb		Replace the bulb.
	Malfunction of the ECU.	–	Replace the ECU.
The alarm sounds in error when, while the system is armed, a door or the liftgate is unlocked by using the key.	Damaged or disconnected wiring of a door key cylinder and the liftgate unlock switch input circuit.	If input checks (P.54-220) indicate a malfunction, check by using check chart P.54-227.	Repair the harness or replace a door key cylinder and the liftgate unlock switch.
	Malfunction of a door key cylinder and the liftgate unlock switch.		
	Malfunction of the ECU.	–	Replace the ECU.

## 2. ACTIVATION / DEACTIVATION RELATIONSHIP

Trouble symptom	Cause	Check method	Remedy
There is no alarm when, as an alarm test, a door is opened without using the key. (The arming and disarming are normal, and the alarm is activated when the liftgate or hood is opened.)	Damaged or disconnected wiring of door switch (all doors) input circuit	If input checks (P.54-220) indicate a malfunction, check by using check chart P.54-225.	Repair the harness or replace the door switch.
	Malfunction of the door switch		
	Malfunction of the ECU	–	Replace the ECU.
There is no alarm when, as an alarm test, the liftgate is opened without using the key. (The alarm is activated, however, by opening a door or the hood.)	Damaged or disconnected wiring of liftgate switch input circuit	If input checks (P.54-220) indicate a malfunction, check by using check chart P.54-228.	Repair the harness or replace the liftgate switch.
	Malfunction of the liftgate switch.		
	Malfunction of the ECU.	–	Replace the ECU.

Trouble symptom	Cause	Check method	Remedy
There is no alarm when, as an alarm test, the hood is opened from within the vehicle. (The alarm is activated, however, by opening a door or the liftgate.)	Damaged or disconnected wiring of hood switch input circuit.	If input checks (P.54-220) indicate a malfunction, check by using check chart P.54-225.	Repair the harness or replace the hood switch.
	Malfunction of the hood switch.		
	Malfunction of the ECU.	–	Replace the ECU.
Engine would not start [Engine starting is possible when the starter relay is in the switched-off (normally closed) condition, with the clutch switch in the switch-off and the ECU harness connector disconnected.]	There is a short-circuit of the starter relay activation circuit	Check by using check chart P.54-234.	Repair the harness.
When, as a test of the alarm, a door or the liftgate is opened without using the key, or the hood is opened from within the vehicle, the horn and the theft-alarm horn sound but the headlights don't flash. (The headlights can, however, be switched ON by using the passing switch.)	Damaged or disconnected wiring of headlight power supply circuit or headlight activation circuit	Check by using check chart P.54-231, 232.	Repair the harness or replace the diode D <sub>2</sub> . Replace the headlight relay or the headlight.
	Malfunction of the ECU		Replace the ECU.
The headlights flash during an alarm test but the horn or the theft alarm horn does not sound.	Damaged or disconnected wiring of horn relay power supply circuit or horn activation circuit Damaged or disconnected wiring of the theft-alarm horn relay power supply circuit or the theft-alarm horn activation circuit.	Check by using check chart P.54-229, 230, 231.	Repair the harness. Replace the horn. Replace dedicated fuse No. (6) or the fusible link No. (6).
	Malfunction of the ECU.		Replace the ECU.
The system is not deactivated when, during an alarm test in which the alarm is intentionally activated, the door or liftgate is unlocked by using the key. (The system also cannot be disarmed.)	Damaged or disconnected wiring of door key cylinder and liftgate unlock switch input circuit	If input checks (P.54-220) indicate a malfunction, check by using check chart P.54-227, 228.	Repair the harness. Replace the key cylinder switch or the liftgate switch.
	Malfunction of door key cylinder and liftgate unlock switch.		
	Malfunction of the ECU		Replace the ECU.

ECU: Electronic Control Unit

NOTE

- (1) If the liftgate unlock switch or door key cylinder unlock switch is operated roughly, or if these switches have been installed incorrectly or switches themselves are defective the ECU may not accept the warning or alarm cancelling signal. In such case, the alarm operation will take place when the door is opened using a key. [When the door key cylinder switch has been shorted, however, if the ignition switch is turned ON, the ECU judges the detection-switch as faulty and thereafter, it will prevent setting of (warning) alarm until the shorting is corrected.]
- (2) If the liftgate is opened using a key and is left opened when the door key cylinder switch system has a trouble (wiring harness damage, open circuit, etc.), the ECU judges it as the liftgate holding mode and does not produce alarm even when the door is opened.

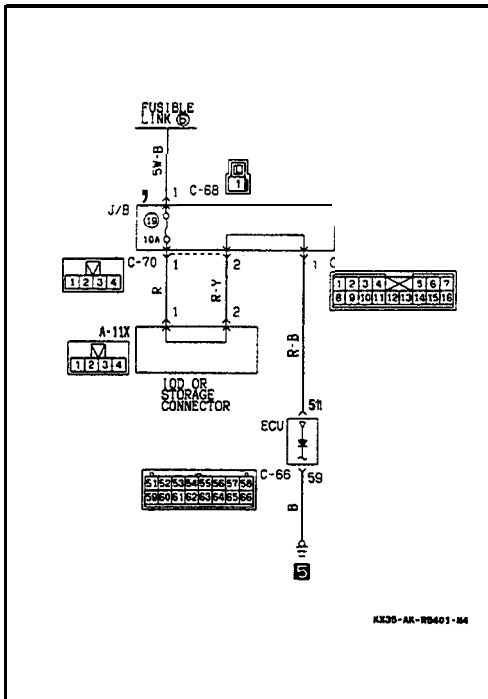

**CHECKING THE CIRCUIT AND INDIVIDUAL PART**  
**1. ETACS POWER-SUPPLY AND GROUND CIRCUITS**

**Description of operation**

The battery supplies a stabilized 5 V power supply to the ECU, via the constant-voltage circuit and terminal 51 (which is directly connected to the battery).

ECU terminal voltage (Connection condition of the ECU connector).

ECU terminal No.	Signal	Condition	Terminal voltage
51	ECU power supply	At all times	12v

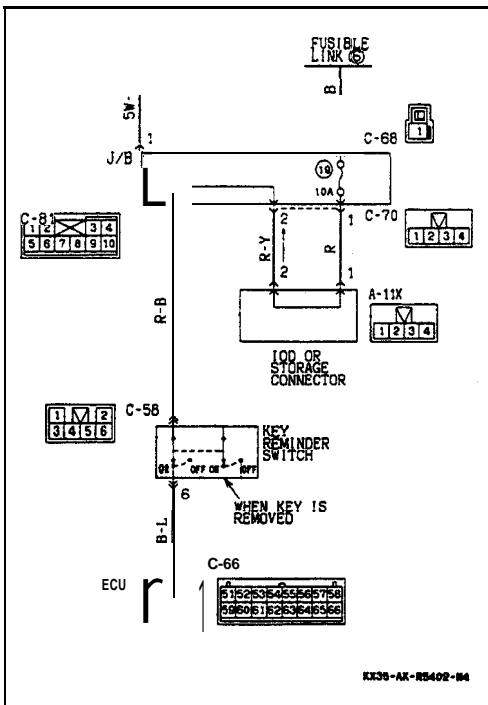

**2. KEY-REMINDER SWITCH INPUT CIRCUIT**

**Description of operation**

The key-reminder switch is switched OFF and HIGH-level signals are sent to the ECU when the key is inserted into the ignition key cylinder: when the key is removed, the key-reminder switch is switched ON and LOW-level signals are sent to the ECU.

ECU terminal voltage (Connection condition of the ECU connector).

ECU terminal No.	Signal	Condition	Terminal voltage
64	Key-reminder switch	Key removed	12 V
		Key inserted	0 V

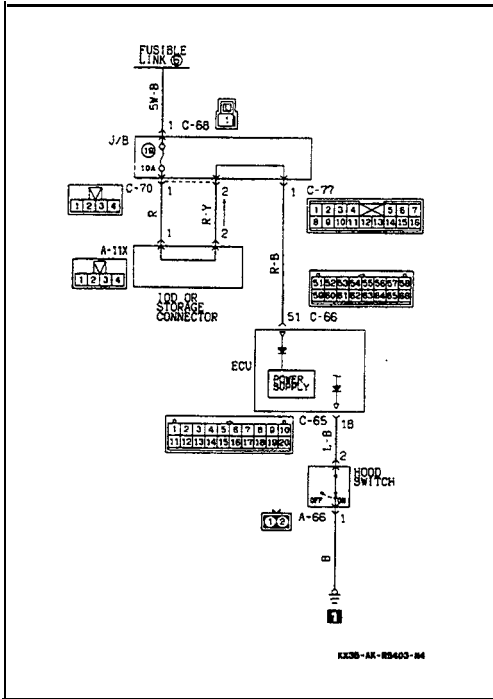

### 3. HOOD SWITCH INPUT CIRCUIT

#### Description of operation

When the hood is closed (the hood switch is switched OFF), HIGH-level signals are sent to the ECU:  
 When the hood is opened (the hood switch is switched ON), LOW-level signals are sent to the ECU.

ECU terminal voltage (Connection condition of the ECU connector).

ECU terminal No.	Signal	condition		Terminal voltage
18	Hood switch	Hood	Open	OV
			Closed	5 V*

\* Measurement is not possible by using a voltmeter, but is possible by using an oscilloscope.

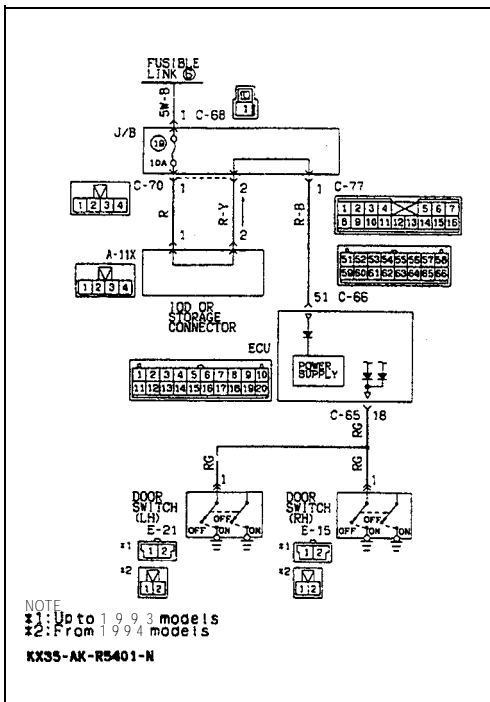

### 4. DOOR SWITCH INPUT CIRCUIT

#### Description of operation

When the door is closed (the door switch is switched OFF), HIGH-level signals are sent to the ECU:  
 When the door is opened (the door switch is switched ON), LOW-level signals are sent to the ECU.

ECU terminal voltage (Connection condition of the ECU).

ECU terminal No.	Signal	Condition		Terminal voltage
10	Driver door switch	Driver door	Open	OV
			Closed	5 V*
	Passenger door switch	Passenger door	Open	0 V
			Closed	5 V*

\* Measurement is not possible by using a voltmeter, but is possible by using an oscilloscope.

NOTE  
 #1: Up to 1993 models  
 #2: From 1994 models  
 KX35-AK-R5401-N

5. DOOR LOCK ACTUATOR SWITCH INPUT CIRCUIT

Description of operation

When a door is locked by the lock knob or the key, the door lock actuator switch is switched OFF, and HIGH-level signals are sent to the ECU. These signals activate the timer circuit of the R ECU, thereby causing the activation circuit to function, thus R activating the door lock actuator of all doors.

ECU terminal voltage (Connection condition of the ECU connector).

ECU terminal No.	Signal	Condition	Terminal voltage
13	Door lock actuator switch (driver door)	Door lock actuator switch	Lock: OFF 5 V*
			Unlock: ON 0 V
14	Door lock actuator switch (passenger door)	Door lock actuator switch	Lock: OFF 5 V*
			Unlock: ON 0 V

\* Measurement is not possible by using a voltmeter, but is possible by using an oscilloscope.

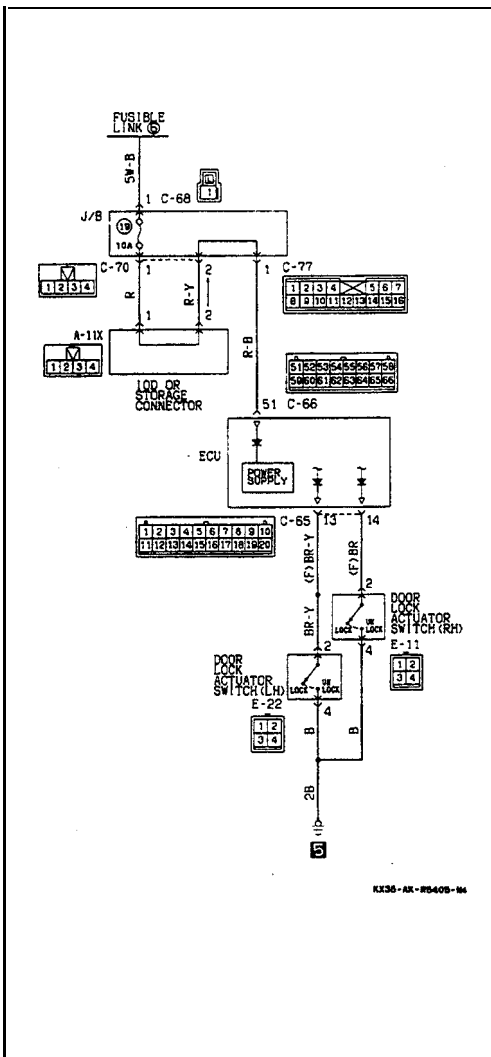

<Up to 1993 models>

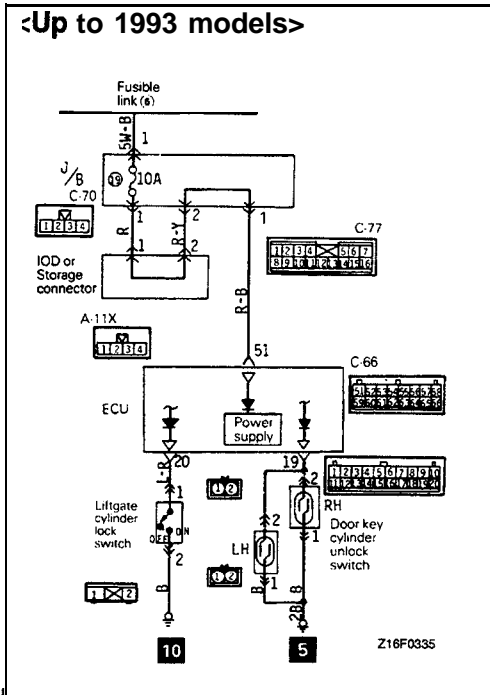

6. DOOR KEY CYLINDER UNLOCK AND LIFTGATE CYLINDER LOCK SWITCH INPUT CIRCUIT

Description of operation

When the door key is rotated or the liftgate key is unlocked, R LOW-level signals are sent to the ECU.

ECU terminal voltage (Connection condition of the ECU R connector).

<Up to 1993 models>

ECU terminal No.	Signal	Condition		Terminal voltage
19	Door key cylinder unlock switch	Door key cylinder (LH)	Not rotate	5 V
			Rotate	0 V
		Door key cylinder (RH)	Not rotate	5 V
			rotate	0 V
20	Liftgate unlock switch	Liftgate Lock	5 V	
		Unlock	0 V	

<From 1994 models>

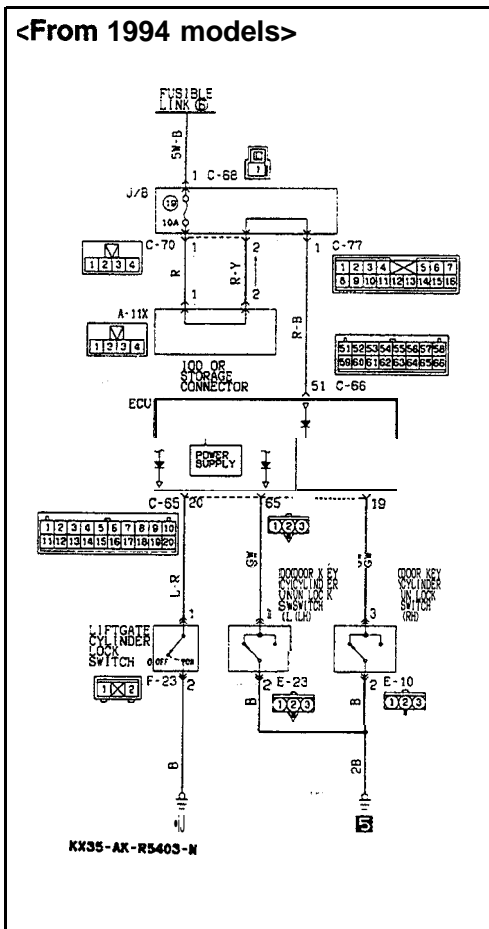

ECU terminal No.	Signal	Condition		Terminal voltage
65	Door key cylinder unlock switch	Door key cylinder (LH)	Not rotate	5 V
			Rotate	0 V
19	Door key cylinder unlock switch	Door key cylinder (RH)	Not rotate	5 V
			Rotate	0 V
20	Liftgate unlock switch	Liftgate Lock	5 V	
		Unlock	0 V	



7. LIFTGATE SWITCH INPUT CIRCUIT

Description of operation

When the liftgate is closed (the liftgate switch is switched ROFF), HIGH-level signals are sent to the ECU. When the liftgate is opened (the liftgate switch is switched R ON), LOW-level signals are sent to the ECU.

ECU terminal voltage (Connection condition of the ECU connector).

ECU terminal No.	Signal	Condition	Terminal voltage
17	Liftgate switch	Open	0 V
		Closed	5 V*

- \* Measurement is not possible by using a voltmeter, but is possible by using an oscilloscope.

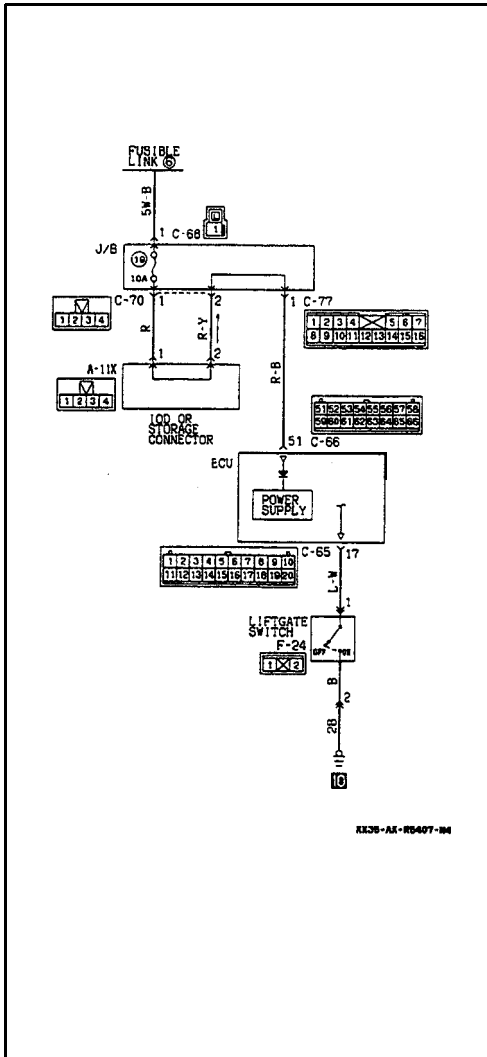

RE35-AR-R0407-00

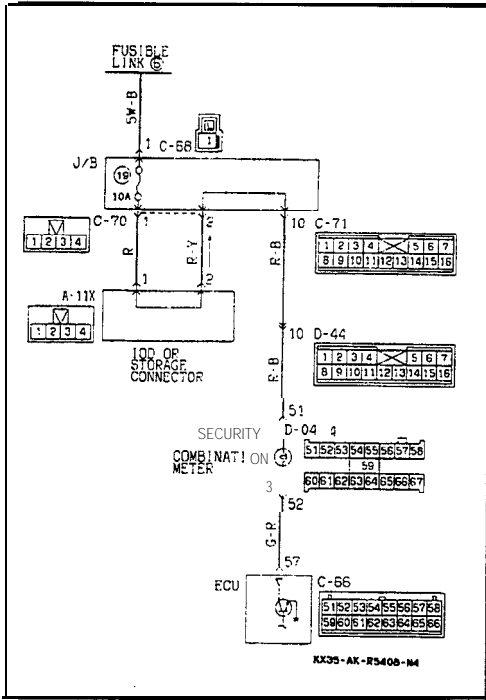

**8. SECURITY LIGHT ACTIVATION CIRCUIT**

**Description of operation**

If all doors are in locked state after key-less locking, the ECU transistor is turned ON and the security light comes on.

Checking the security light activation circuit (Disconnect the connector of the ECU and check at the wiring harness side.)

Step	Check object	Normal condition	Mal-function	Cause	Remedy
1	D-04 connector terminal voltage 51	12v	ov	Fuse (19) <b>damaged</b> or <b>disconnected</b>	Replace the fuse
				Harness <b>damaged</b> or <b>disconnected</b> , or <b>short-circuit</b>	Repair the harness
2	D-04 connector terminal voltage 52	12v	ov	Damaged or <b>disconnected</b> wiring of SECURITY light bulb	Replace the bulb
				Harness <b>damaged</b> or <b>disconnected</b>	Repair the harness
3	ECU terminal voltage 57	12v	ov	Harness <b>damaged</b> or <b>disconnected</b> , or <b>short-circuit</b>	Repair the harness

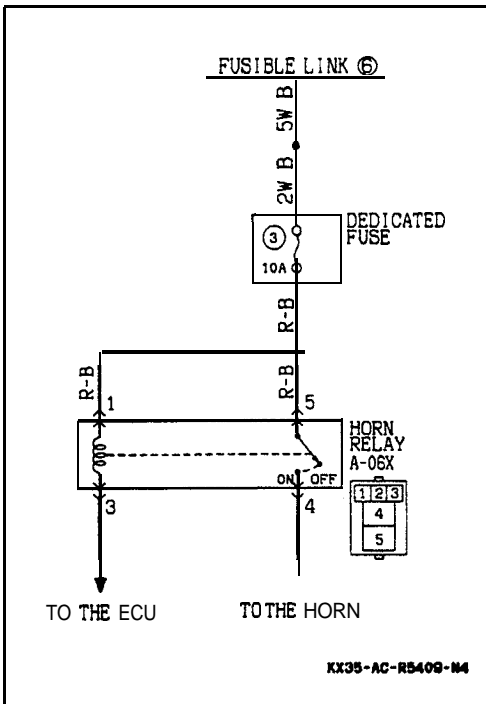

**9. HORN RELAY POWER-SUPPLY CIRCUIT**

**Description of operation**

Power voltage is always supplied to the horn relay.

Checking the horn relay power-supply circuit (Disconnect the horn relay)

Check object	Normal condition	Mal-function	Cause	Remedy
HORN RELAY connector terminal voltage 5	12 V	0 V	Fuse (3) <b>damaged</b> or <b>disconnected</b>	Replace the fuse
			Damaged or <b>disconnected</b> harness	Repair the harness

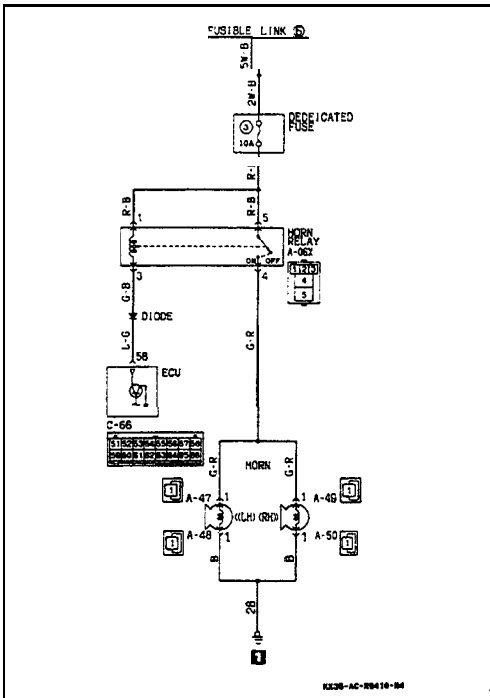

10. HORN ACTIVATION CIRCUIT

Description of operation

The ECU transistor is turned ON if the vehicle door, etc. are opened without use of the key.

This energizes the horn relay to activate the horn.

Checking the horn activation circuit (Disconnect the connector of the ECU, then short-circuit terminal connector No.58, and activate the horn relay.)

Step	Check object	Normal condition	Malfunction	Cause	Remedy
1	Horn relay terminal voltage (4-Ground)	12v	0v	Malfunction of the horn relay	Check the horn relay (Refer to P.54-118.)
2	Horn terminal voltage (LH & RH) (1-Ground)	12v	0v	Harness damaged or disconnected	Repair the harness
3	Horn terminal voltage (LH & RH) (1-Ground)	Horn sounds (0 V)	Horn doesn't sound (0 V)	Malfunction of the horn	Replace the horn
			Battery voltage	Damaged or disconnected wiring of ground circuit	Repair the harness

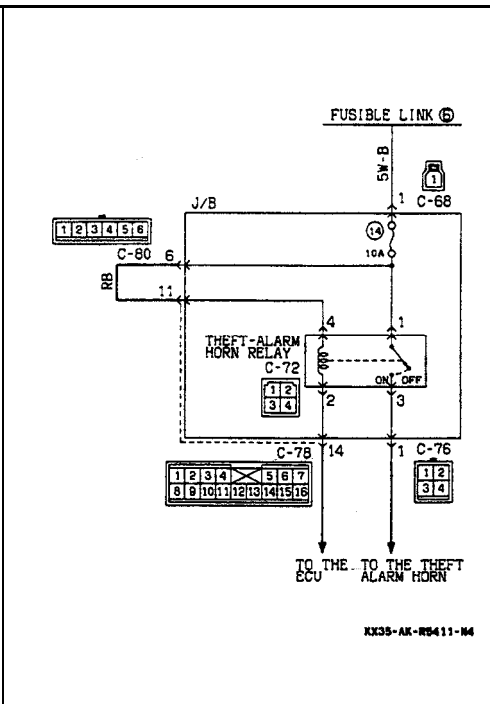

11. THEFT ALARM HORN RELAY POWER-SUPPLY CIRCUIT

Description of operation

Power voltage is always supplied to theft alarm horn relay.

Checking the horn relay power-supply circuit (Disconnect the theft alarm horn relay)

Check object	Normal condition	Malfunction	Cause	Remedy
THEFT ALARM HORN RELAY connector terminal voltage 1	12v	0 v	Fuse (14) damaged or disconnected	Replace the fuse
			Damaged or disconnected harness	Repair the harness

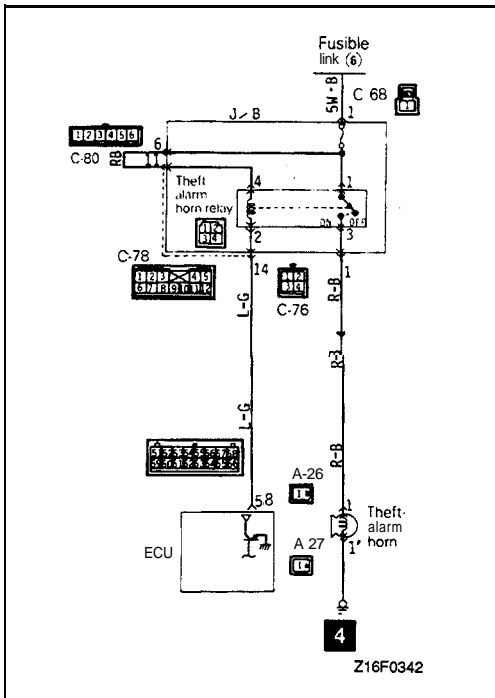

**12. THEFT ALARM HORN ACTIVATION CIRCUIT**

**Description of operation**

The ECU transistor is turned ON if the vehicle door, etc. are opened without use of the key.

This energizes the theft alarm horn relay to activate the horn.

Checking the horn activation circuit (Disconnect the connector of the ECU, then short-circuit terminal connector No. 58, and activate the theft alarm horn relay.)

Step	Check object	Normal condition	Malfunction	Cause	Remedy
1	Horn relay terminal voltage (1-Ground)	12 V	0 V	Malfunction of the horn relay	Check the horn relay (Refer to P.54-118.)
2	Horn terminal voltage (1-Ground)	12 V	0 V	Harness damaged or disconnected	Repair the harness
3	Horn terminal voltage (1-Ground)	Horn sounds (0 V)	Horn doesn't sound (0 V)	Malfunction of the horn	Replace the horn
				Battery voltage	Damaged or disconnected wiring of ground circuit

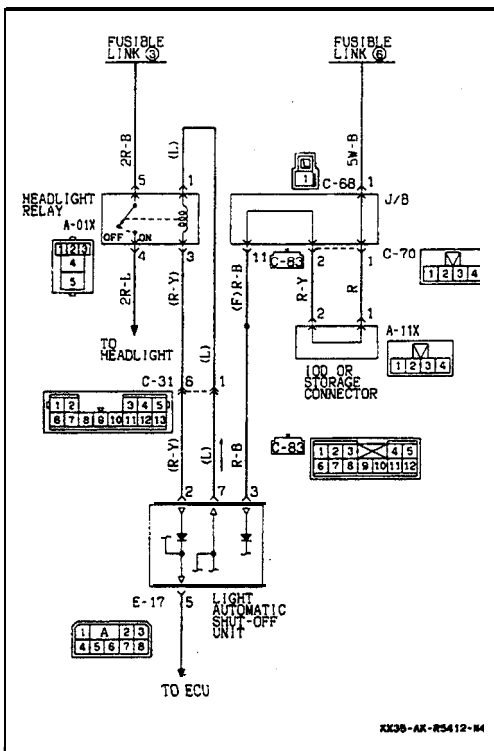

**13. HEADLIGHT POWER-SUPPLY CIRCUIT**

**Description of operation**

Power voltage is always supplied to the headlight relay.

Checking the headlight power-supply circuit (Disconnect the headlight relay)

Check object	Normal condition	Malfunction	Cause	Remedy
(Wiring harness side) terminal voltage (5-Ground)	12 v	0 v	Fusible link (3) blown	Replace the fusible link
			Damaged or disconnected harness	Repair the harness

14. HEADLIGHT ACTIVATION CIRCUIT

<Up to 1993 models>

<From 1994 models>

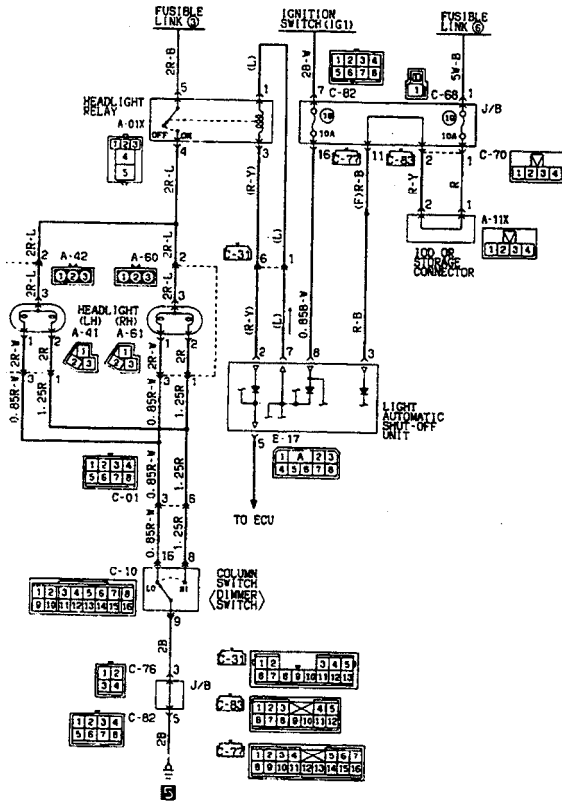

KX35-AK-R5413A-B4

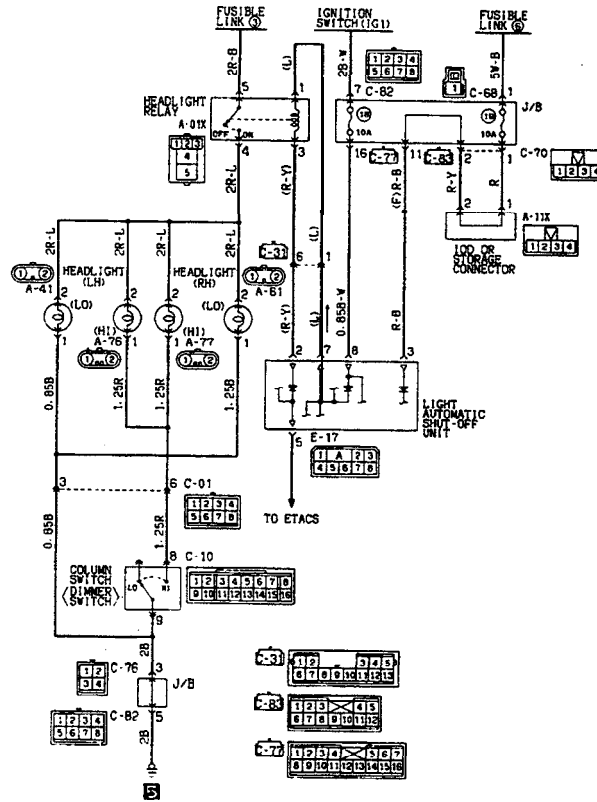

KX35-AK-R5413-B4  
00002536

**Description of operation**

The ECU transistor is turned ON if the vehicles door, etc. are opened without use of the key. This energizes the headlight relay to activate the headlight.

Checking the headlight activation circuit (Disconnect the connector of the ECU, then short-circuit terminal connector 2, and activate the headlight relay.)

<Up to 1993 models>

Step	Check object	Normal condition	Mal-function	Cause	Remedy	
1	Headlight relay terminal voltage (4-Ground)	12V	OV	Malfunction of the headlight relay	Check the headlight relay (Refer to P.54-108.)	
2	Headlight terminal voltage (3-Ground)	12v	OV	Harness damaged or disconnected	Repair the harness	
3	Headlight terminal voltage (1 -Ground)	Column switch: Low	OV	The headlight isn't turned on.	Malfunction of the headlight. Harness damaged or disconnected. Malfunction of column switch.	Replace the headlight or column switch. Repair the harness.
		Column switch: Hi	12V			
	Headlight terminal voltage (2-Ground)	Column switch: Low	12V			
		Column switch: Hi	OV			

<From 1994 models>

Step	Check object	Normal condition	Mal-function	Cause	Remedy	
1	Headlight relay terminal voltage (4-Ground)	12v	ov	Malfunction of the headlight relay	Check the headlight relay (Refer to P.54-108.)	
2	Headlight terminal voltage (2-Ground)	12v	ov	Harness damaged or disconnected	Repair the harness	
3	Headlight (HI) terminal voltage (1 -Ground)	Column switch: Low	12v	The headlight isn't turned on.	Malfunction of the headlight. Harness damaged or disconnected. Malfunction of column switch.	Replace the headlight or column switch. Repair the harness.
		Column switch: Hi	OV			
	Headlight (LO) terminal voltage (2-Ground)	Column switch: Low	OV			
		Column switch: Hi	OV			

15. STARTER RELAY ACTIVATION CIRCUIT

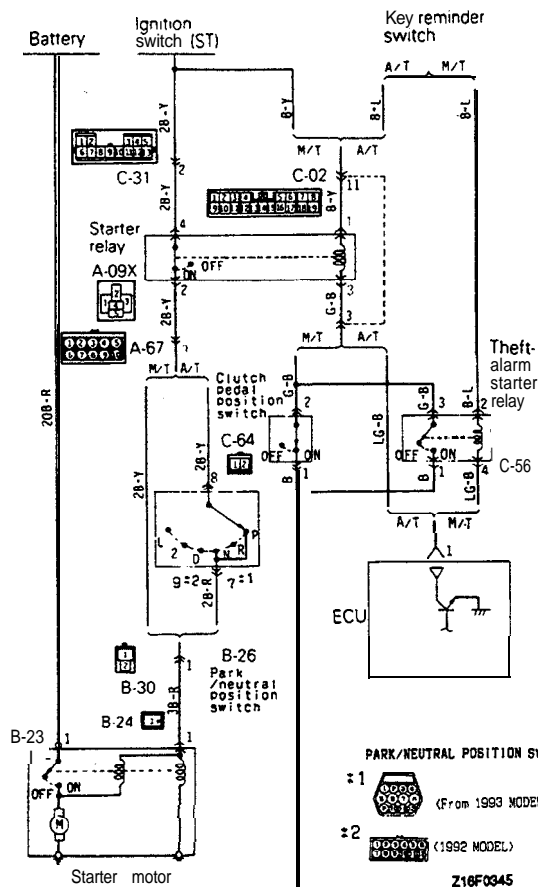

Description of operation

The ECU transistor is turned ON if the vehicle door etc. are opened without use of the key. This turns OFF the starter relay and power ceases to be supplied to the starter magnet switch.

Checking the starter relay activation circuit (Disconnect the connector of the ECU, depress fully the clutch pedal and activate the starter relay)

Step	Check object	Normal condition	Malfunction	Cause	Remedy
1	Starter relay terminal voltage (2-Ground)	12v	0v	Malfunction of the starter relay	Check the starter relay
2	Starter motor terminal (1 -Ground)	12v	0v	Harness damaged or disconnected	Repair the harness
(Starter motor connector B-24: Separation)					
3	Continuity between "B-24" connector and ground	0 Ω	∞ Ω	Damaged magnet switch	Replace magnet switch

## A

ABS	
POWER RELAY, Check	35-82-I
RELAY	35-110-I
SIGNAL, On-vehicle Inspection	13A-176, 277-I
ACCELERATOR	
CABLE	17-4-I
SWITCH	
<Automatic Transaxle>	23-51-I
<Engine and Emission Control>	17-4-I
ACTIVE AERO SYSTEM, Check	51-7-I
ACTIVE EXHAUST	
CONTROL UNIT, On-vehicle Inspection	13A-173, 274-I
SYSTEM	15-40-I
AERO PARTS	51-19-I
AIR BAG	52B-74-I
MODULE	52B-82, 87-I
AIR CLEANER	15-9-I
ELEMENT, Maintenance	00-45-I
AIR CONDITIONING	55-3-I
<Full Auto A/C>	55-54-I
<Manual A/C>	55-6-I
COMPRESSOR	
<Full Auto A/C>	55-79-I
<Manual A/C>	55-39-I
COMPRESSOR DRIVE BELT, Adjustment	55-18-I
CONTROL PANEL	55-73-I
CONTROL UNIT	55-73-I
ENGINE COOLANT TEMPERATURE SWITCH	
Engine Cooling	14-13-I
<Full Auto A/C>	55-79-I
<Manual A/C>	55-53-I
POWER RELAY	55-29-I
POWER TRANSISTOR	55-74-I
SWITCH	55-33-I
Emission Control	17-65-I
On-vehicle Inspection	13A-123, 236-I
ANTENNA	
Motor	54-188-II
FEEDER CABLE	54-188-II
ANTI-LOCK BRAKE SYSTEM	Refer to ABS
ASSIST LINK <AWD>	34-35-I
AUTOMATIC TRANSAXLE	23-64-I
Maintenance	00-49-I
AXLE	
Rear	
<AWD>	27-6-I
<FWD>	27-2-I
HUB, Rear <FWD>	27-4-I
SHAFT <AWD>	27-16-I

## B

BALL JOINT SEALS, Maintenance	00-52-I
BAROMETRIC PRESSURE SENSOR	
On-vehicle Inspection	13A-91, 217-I
BASIC IDLE SPEED, Adjustment	13A-55-I
BATTERY	54-3-II
Discharged, Remedy	35-82-I
BELT LOCK CONTROLLER	55-32, 74-I
BLOWER	55-35-I
BOOSTER, Clutch <AWD>	21-6-I
BOOST METER, On-vehicle Inspection	13A-171, 273-I
BRAKE	
Parking	36-8-I
BOOSTER	35-87-I
Operating Check	35-64-I

DISC	35-93, 103-I
Front, Check	35-70-I
Rear, Check	35-73-I
FLUID LEVEL SENSOR, Check	35-64-I
HOSES, Maintenance	00-52-I
LINE	35-91-I
LINING	35-74-I
PAD	
Disc, Front	35-66-I
Disc, Rear	35-71-I
PEDAL	35-84-I
Check and Adjustment	35-63-I
BUMPER	
Front	51-8-I
Rear	51-13-I

## C

CAMSHAFT	
OIL SEALS	11-21-I
POSITION SENSOR, On-vehicle Inspection	13A-103, 225-I
CATALYTIC CONVERTER	17-71-I
<Non Turbo>	15-30-I
<Turbo>	15-33-I
CD AUTO CHANGER	54-191-II
CENTER PILLAR GLASS	42-33-I
CENTRAL DOOR LOCKING SYSTEM	42-49-I
CHARGE AIR COOLER	15-11-I
CHARGING SYSTEM	16-2-II
CIGARETTE LIGHTER	54-123-II
CLOCK SPRING, SRS	52B-74-I
CLOSED THROTTLE POSITION SWITCH	
Adjustment	13A-57-I
On-vehicle Inspection	13A-101, 223-I
CLUTCH	
BOOSTER OPERATING, Check <AWD>	21-6-I
CONTROL	21-10-I
COVER	21-20-I
DISC	21-20-I
MASTER CYLINDER	21-14-I
PEDAL	21-8-I
Check and Adjustment	21-5-I
RELEASE CYLINDER	21-16-I
VACUUM LINE <AWD>	21-18-I
COLUMN SWITCH	54-112-II
COMBINATION GAUGES	54-33-II
COMBINATION LIGHT	54-106-II
COMBINATION METERS	54-31-II
COMPRESSOR CLUTCH RELAY,	
On-vehicle Inspection	13A-123, 236-I
CONDENSER	
<Full Auto A/C>	55-79-I
<Manual A/C>	55-46-I
FAN MOTOR	
<Full Auto A/C>	55-79-I
<Manual A/C>	55-46-I
CONTROL CABLE, A/T	23-55-I
CONTROLLER, Belt Lock	55-32-I
CONTROL UNIT	
Active Exhaust, On-vehicle Inspection	13A-173, 274-I
ECS	33B-20-I
Electronic <ABS>	35-119-I
CONTROL VALVE	37B-9-I
Fuel Tank Pressure	13F-6-I
Inspection	17-65-I
CRANKSHAFT	
FRONT OIL SEAL	11-25-I
POSITION SENSOR, On-vehicle Inspection	13A-107, 227-I
REAR OIL SEAL	11-26-I



CROSSMEMBER .....	32-8-I
CRUISE CONTROL .....	17-I
CABLE, Check and Adjustment .....	17-31-I
SYSTEM .....	17-38-I
Check .....	17-32-I
CURB IDLE SPEED, Check .....	11-11-I
CYLINDER HEAD GASKET .....	11-28-I

**D**

DAMPER CONTROL MOTOR .....	55-75-I
DAMPING FORCE CHANGEOVER ACTUATOR .....	33B-19-I
DASHPOT, Check And Adjustment .....	11-13-I
DEFOGGER	
Rear Window .....	54-192-II
RELAY .....	54-204-II
SWITCH, Rear Window .....	54-203-II
DIFFERENTIAL	
Case, Limited Slip <AWD> .....	27-40-I
Limited Slip, Check <AWD> .....	27-15-I
CARRIER <AWD> .....	27-25-I
DISC BRAKE	
Front .....	35-93-I
Rear .....	35-103-I
PADS, Maintenance .....	00-52-I
DOOR .....	42-41-I
Adjustment .....	42-12-I
GLASS .....	42-43-I
HANDLE .....	42-47-I
INSIDE HANDLE, Play Check .....	42-16-I
LATCH .....	42-47-I
MIRROR .....	51-31-I
REGULATOR .....	42-43-I
TRIM .....	42-42-I
WATERPROOF FILM .....	42-42-I
WINDOW GLASS, Adjustment .....	42-12-I
DRIP LINE WEATHERSTRIP .....	42-63-I
DRIVE BELT	
Compressor, Adjustment .....	55-18-I
Maintenance .....	00-47-I
Tension, Adjustment .....	11-7-I
Tension, Check .....	37A-9-I
DRIVE SHAFT	
Front .....	26-12-I
Rear .....	27-19-I
BOOTS, Maintenance .....	00-52-I
OIL SEALS, Replacement <A/T> .....	23-53-I
<M/T AWD> .....	22-15-I
<M/T FWD> .....	22-5-I

**E**

ECS	
On-vehicle Inspection .....	338-I 1-I
CONTROL UNIT .....	33B-20-I
INDICATOR LIGHT .....	33B-19-I
SWITCH .....	33B-18-I
EGR	
SOLENOID .....	17-70-I
On-vehicle Inspection .....	13A-164, 269-I
SYSTEM, Inspection .....	17-67-I
TEMPERATURE SENSOR .....	17-68-I
On-vehicle Inspection .....	13A-135, 246-I
VALVE .....	17-68-I
VALVE CONTROL VACUUM, Check .....	17-67-I
ELECTRICAL LOAD SWITCH, On-vehicle Inspection .....	13A-127, 238-I
ELECTRONIC CONTROL UNIT <ABS> .....	35-119-I
ENGINE	
CONTROL .....	17-5-I

COOLANT	
Maintenance .....	00-51-I
Replacement .....	14-4-I
COOLANT TEMPERATURE GAUGE UNIT .....	14-13-I
COOLANT TEMPERATURE SENSOR	
Engine and Emission Control .....	17-65-I
Engine Cooling .....	14-13-I
On-vehicle Inspection .....	13A-93, 219-I
HOOD .....	42-18-I
MOUNTING .....	32-3-I
OIL, Maintenance .....	00-47-I
OIL COOLER .....	11-36-I
OIL FILTER, Maintenance .....	00-48-I
ROLL STOPPER .....	32-6-I
SPEED ADJUSTING SCREW, Adjustment .....	13A-59-I
EVAPORATIVE EMISSION	
CANISTER .....	17-65-I
CONTROL SYSTEM .....	17-57-I
Check for Leaks and Clogging .....	00-46-I
PURGE SOLENOID .....	17-64-I
On-vehicle Inspection .....	13A-162, 268-I
EVAPORATOR .....	55-37-I
EXHAUST	
GAS RECIRCULATION (EGR) SYSTEM .....	17-66-I
MANIFOLD	
<Non Turbo> .....	15-26-I
<Turbo> .....	15-28-I
PIPE	
<Non Turbo> .....	15-30-I
<Turbo> .....	15-33-I
SYSTEM	
Active .....	15-40-I
Maintenance .....	00-60-I

**F**

FAN MOTOR	
Condenser	
<Full Auto A/C> .....	55-79-I
<Manual A/C> .....	55-46-I
RELAY, On-vehicle Inspection .....	13A-129, 240-I
FEEDER CABLE, Antenna .....	54-188-II
FENDER .....	42-24-I
FILLER TUBE CAP, Fuel Tank, Check .....	17-65-I
FLOOR CONSOLE .....	52A-10-I
FLOOR PAN, Check .....	42-16-I
FOG LIGHT .....	54-105-II
SWITCH .....	54-109-II
FRONT IMPACT SENSORS .....	52B-68-I
FUEL	
FILLER DOOR, Adjustment .....	42-12-I
FILTER .....	13F-10-I
GAUGE UNIT .....	13F-6-I
HOSES, Maintenance .....	00-45-I
LINE .....	13F-8-I
PRESSURE SOLENOID, On-vehicle Inspection .....	13A-166, 270-I
PRESSURE TEST, On-vehicle Inspection .....	13A-180, 279-I
PUMP .....	13F-6-I
On-vehicle Inspection .....	13A-72, 200-I
PUMP CIRCUIT RESISTOR, On-vehicle Inspection .....	13A-84, 211-I
PUMP OPERATION CHECK, On-vehicle Inspection .....	13A-179, 279-I
PUMP RELAY NO.2, On-vehicle Inspection .....	13A-84, 211-I
SYSTEM, Maintenance .....	00-45-I
FUEL TANK	
FILLER DOOR .....	42-23-I
FILLER TUBE CAP, Check .....	17-65-I
PRESSURE CONTROL VALVE .....	13F-6-I
Inspection .....	17-65-I
FULL AUTO AIR CONDITIONING .....	55-54-I

FUNCTION, Check (4WS) . . . . . 37B-5-I

&lt;Turbo&gt; . . . . . 15-1 5-I

**G**

GARNISHES . . . . . 51-15-I  
 GENERATOR . . . . . 16-12-II  
 GLASS  
   Center Pillar . . . . . 42-33-I  
   Door . . . . . 42-43-I  
   Door Window, Adjustment . . . . . 42-12-I  
   Liftgate . . . . . 42-38-I  
   Quarter Window . . . . . 42-34-I  
   Window . . . . . 42-26-I  
 G SENSOR.. . . . 33B-18-I  
 <AWD-ABS> . . . . . 35-117-I

**H**

HAZARD SWITCH . . . . . 54-110-II  
 HEADLIGHT . . . . . 54-103-II  
 HEADLINING . . . . . 52A-16-I  
 HEATED OXYGEN SENSOR  
   On-vehicle Inspection . . . . . 13A-137, 247-I  
 HEATER . . . . . 55-3-I  
 HEATER CONTROL . . . . . 55-30-I  
 HEATER UNIT . . . . . 55-34-I  
 HIGH MOUNTED STOP LIGHT . . . . . 54-107-II  
 HOOD . . . . . 42-18-I  
   Adjustment . . . . . 42-11-I  
 HORN . . . . . 54-115-II  
   RELAY.. . . . 54-118-II  
   SWITCH . . . . . 54-118-II  
 HYDRAULIC UNIT <ABS> . . . . . 35-110-I  
   Check . . . . . 35-76-I

**I**

IDLE AIR CONTROL MOTOR (Stepper Motor Type)  
   On-vehicle Inspection . . . . . 13A-153, 263-I  
 IDLE MIXTURE, Check . . . . . 11-12-I  
 IDLE SPEED  
   Basic, Adjustment . . . . . 13A-55-I  
   Curb, Check . . . . . 11-11-I  
 IGNITION  
   CABLES, Maintenance . . . . . 00-46-I  
   COIL, On-vehicle Inspection . . . . . 13A-158, 264-I  
   POWER TRANSISTOR, On-vehicle Inspection . . . . . 13A-158, 264-I  
   SWITCH . . . . . 54-6-II  
   SWITCH-IG, On-vehicle Inspection . . . . . 13A-65, 193-I  
   SWITCH-ST, On-vehicle Inspection  
     <A/T> . . . . . 13A-113, 230-I  
     <M/T> . . . . . 13A-112, 229-I  
   SYSTEM . . . . . 16-45-II  
   TIMING, Check . . . . . 11-9-I  
 IMPACT SENSORS, Front . . . . . 52B-68-I  
 INDUCTION CONTROL VALVE POSITION SENSOR  
   On-vehicle Inspection . . . . . 13A-133, 242-I  
 INJECTOR . . . . . 13A-286-I  
   On-vehicle Inspection . . . . . 13A-144, 257-I  
 INSTRUMENT PANEL . . . . . 52A-5-I  
 INTAKE  
   AIR TEMPERATURE SENSOR . . . . . 17-65-I  
     On-vehicle Inspection . . . . . 13A-88, 215-I  
   CHARGE PRESSURE CONTROL SYSTEM, Check . . . . . 15-7-I  
 INTAKE MANIFOLD . . . . . 15-17-I  
 PLENUM  
   <Non Turbo> . . . . . 15-13-I

**K**

KEY INTERLOCK MECHANISM . . . . . 23-51-I  
 KEYLESS ENTRY SYSTEM . . . . . 42-52-I  
 KICKDOWN SERVO . . . . . 23-47-I  
 KNOCK SENSOR . . . . . 13A-289-I  
   On-vehicle Inspection . . . . . 13A-125, 237-I  
 KNUCKLE . . . . . 26-6-I

**L**

LASH ADJUSTERS  
   Check . . . . . 11-15-I  
   Replacement . . . . . 11-17-I  
 LATCH, Door . . . . . 42-47-I  
 LEFT MEMBER . . . . . 32-8-I  
 LEVER, Shift  
   <AWD> . . . . . 22-16-I  
   <FWD> . . . . . 22-8-I  
 LICENSE PLATE LIGHT . . . . . 54-106-II  
 LIFTGATE . . . . . 42-20-I  
   Adjustment . . . . . 42-11-I  
   GLASS . . . . . 42-38-I  
 LIGHT  
   Indicator, ECS . . . . . 33B-19-I  
   Fog . . . . . 54-105-II  
   Front Combination . . . . . 54-106-II  
   High Mounted Stop . . . . . 54-107-II  
   License Plate . . . . . 54-106-II  
   Rear Combination . . . . . 54-106-II  
   Switch, Stop . . . . . 33B-19-I  
 LIGHTING SYSTEM . . . . . 54-35-II  
 LIMITED SLIP DIFFERENTIAL  
   Check <AWD> . . . . . 27-15-I  
   Rear Axle, Oil Change, Maintenance . . . . . 00-52-I  
   CASE <AWD> . . . . . 27-40-I  
 LOOSE PANEL . . . . . 42-25-I  
 LOWER ARM  
   Front Suspension . . . . . 33A-10-I  
   Rear Suspension  
     <AWD> . . . . . 34-29-I  
     <FWD> . . . . . 34-9-I

**M**

MAIN MUFFLER  
   <Non Turbo> . . . . . 15-30-I  
   <Turbo> . . . . . 15-33-I  
 MANUAL AIR CONDITIONING . . . . . 55-6-I  
 MANUAL TRANSAXLE  
   <AWD> . . . . . 22-13-I  
   <FWD> . . . . . 22-2-I  
   Maintenance . . . . . 00-48-I  
 MASTER CYLINDER . . . . . 35-87-I  
   Clutch . . . . . 21-14-I  
 MIRROR, Door.. . . . 51-31-I  
 MIXTURE CONTROL (MFI) System . . . . . 17-70-I  
 MOTOR ANTENNA.. . . . 54-188-II  
 MOTOR RELAY <ABS>, Check . . . . . 35-83-I  
 MOULDINGS . . . . . 51-15-I  
 MUFFLER, Main  
   <Non Turbo> . . . . . 15-30-I  
   <Turbo> . . . . . 15-33-I  
 MUFFLER MODE CHANGEOVER SWITCH  
   On-vehicle Inspection . . . . . 13A-131, 241-I

## O

OIL	
Transmission, Replacement	
<AWD>	22-15-I
<FWD>	22-4-I
COOLER	
Engine	11-36-I
Transaxle	23-62-I
COOLER HOSES, Transaxle	23-62-I
COOLER TUBES, Transaxle	23-62-I
FILTER, Engine, Maintenance	00-48-I
LEVEL, Gear, Check <AWD>	27-14-I
LEVEL, Transmission, Check	
<AWD>	22-15-I
<FWD>	22-4-I
PAN	11-23-I
PRESSURE SWITCH, Power Steering, Check	37A-13-I
SCREEN	11-23-I
OPTICAL HORN LENS	54-106-II

## P

PARK/NEUTRAL POSITION SWITCH	
Adjustment	23-53-I
On-vehicle Inspection	13A-113, 230-I
PARKING BRAKE	36-8-I
CABLE	36-5-I
LEVER	36-5-I
Stroke Check	36-4-I
SWITCH, Check	36-4-I
POP-UP SWITCH	54-109-II
POSITION DETECTION SWITCH	33B-19-I
POSITIVE CRANKCASE VENTILATION	
SYSTEM, Inspection	17-56-I
VALVE	17-56-I
POWER STEERING	
Stationary Steering Effort Check	37A-9-I
FLUID	37A-10-I
GEAR BOX	37A-18-I
HOSES	37A-33-I
OIL PRESSURE SWITCH, Check	37A-13-I
OIL PUMP	37A-29-I
Pressure Test	37A-12-I
PRESSURE SWITCH	
On-vehicle Inspection	13A-121, 235-I
POWER WINDOW	42-44-I
PROPELLER SHAFT	25-3-I
PROPORTIONING VALVE, Function Test	35-65-I
PURGE CONTROL	
SYSTEM, Check	
<Non Turbo>	17-58-I
<Turbo>	17-60-I
VALVE <Turbo>	17-64-I
PURGE PORT VACUUM, Check	17-63-I

## R

RADIATOR	14-5-I
CAP, Pressure Test	14-4-I
RADIO	54-186-II
ANTI-THEFT SYSTEM	54-156-II
RADIO REMOTE-CONTROL	54-186-II
REAR OIL PUMP, 4WS	37B-11-I
DISCHARGE FLOW VOLUME, Check	37B-5-I
REAR WINDOW DEFOGGER	54-192-II
SWITCH	54-203-II
REFRIGERANT	

Leak Repair Procedure	55-28-I
LINE	
<Full Auto A/C>	55-79-I
<Manual A/C>	55-48-I
REGULATOR, Door	42-43-I
RELEASE CYLINDER, Clutch	21-16-I
RESISTOR	55-32-I
RHEOSTAT	54-110-II
RIGHT MEMBER	32-8-I

## S

SEAT	
Front	52A-17-I
Rear	52A-25-I
SEAT BELT	52A-26-I
SELECTOR LEVER	23-59-I
Operation Check	23-51-I
SENSOR	
Barometric Pressure	Refer to B
Brake Fluid Level, Check	35-64-I
Camshaft Position	Refer to C
Crankshaft Position	Refer to C
EGR Temperature	Refer to E
Engine Coolant Temperature	Refer to E
Front Impact	52B-68-I
G	
<ACTIVE ECS>	33B-18-I
<AWD-ABS>	35-117-I
Heated Oxygen	Refer to H
Induction Control Valve Position	Refer to I
Intake Air Temperature	Refer to I
Knock	Refer to K
Steering Angular Velocity	33B-18-I
Throttle Position	Refer to T
Vehicle Speed	Refer to V
Volume Air Flow	Refer to V
Wheel Speed	Refer to W
SHIFT LEVER	
<AWD>	22-16-I
<FWD>	22-8-I
SHIFT LOCK MECHANISM, Check	23-52-I
SHOCK ABSORBER	
<AWD>	34-36-I
<FWD>	34-13-I
SOLENOID	
EGR <California-Non Turbo, Turbo>	17-70-I
EGR, On-vehicle Inspection	13A-164, 269-I
Evaporative Emission Purge	Refer to E
Fuel Pressure	Refer to F
Turbocharger Waste Gate	Refer to T
SPARK PLUG	
Maintenance	00-46-I
CABLE	16-36-II
SPEAKER	54-187-II
SPEEDOMETER CABLE	
Replacement	
<A/T>	23-54-I
<M/T FWD>	22-4-I
SPEED SENSOR, Wheel <ABS>	35-113-I
SPEED SENSOR, Wheel, Output Voltage Measurement	35-75-I
SRS	
Maintenance	00-53-I
DIAGNOSIS UNIT (SDU)	52B-71-I
STABILIZER BAR	
Front Suspension	33A-12-I
Rear Suspension	
<AWD>	34-38-I
<FWD>	34-16-I

STARTER MOTOR .....	16-23-II	<M/T AWD> .....	22-17-I
STARTING SYSTEM .....	16-19-II	<M/T FWD> .....	22-6-I
STEERING		MOUNTING .....	32-5-I
Angle Check .....	37A-6-I	OIL COOLER .....	23-62-I
ANGULAR VELOCITY SENSOR .....	33B-18-I	OIL COOLER HOSES .....	23-62-I
GEAR BOX, Power .....	37A-18-I	OIL COOLER TUBES .....	23-62-I
LINKAGE SEALS, Maintenance .....	00-52-I	OIL SEAL <AWD> .....	22-16-I
SHAFT .....	37A-14-I	TRANSFER <AWD> .....	22-22-I
STEERING WHEEL .....	37A-14-I	TRANSMISSION	
Centering .....	37A-7-I	FLUID .....	23-47-I
Free Play Check .....	37A-6-I	OIL	
Return to Center Check .....	37A-9-I	Replacement	
STOP LIGHT		<AWD> .....	22-15-I
High Mounted .....	54-107-II	<FWD> .....	22-4-I
SWITCH .....	33B-19-I	TRIM .....	52A-11-I
STRUT .....	33A-7-I	Door .....	42-42-I
SUN ROOF .....	42-56-I	TURBOCHARGER	
SUSPENSION		<FRONT> .....	15-20-I
Rear		<REAR> .....	15-23-I
<AWD> .....	34-26-I	BYPASS VALVE, Check .....	15-8-I
<FWD> .....	34-7-I	SUPERCHARGING PRESSURE .....	15-6-I
SWITCH		WASTE GATE SOLENOID	
Accelerator .....	Refer to A	Check .....	15-8-I
Air Conditioning Engine Coolant Temperature .....	Refer to A	On-vehicle Inspection .....	13A-169, 271-I
Closed Throttle Position .....	Refer to C		
Column .....	54-112-II	<b>U</b>	
ECS .....	33B-18-I	UPPER ARM	
Electrical Load .....	13A-127, 238-I	<AWD> .....	34-29-I
Fog Light .....	54-109-II	<FWD> .....	34-9-I
Hazard .....	54-110-II	<b>V</b>	
Horn .....	54-118-II	VACUUM TANK <AWD> .....	21-18-I
Ignition .....	54-6-II	VALVE RELAY <ABS>, Check .....	35-83-I
Ignition-IG .....	Refer to I	VAPOR LINE .....	13F-8-I
Ignition-ST .....	Refer to I	VARIABLE INDUCTION CONTROL	
Muffler Mode Changeover .....	Refer to M	MOTOR (DC Motor) .....	13A-174, 276-I
Parking Brake, Check .....	36-4-I	SYSTEM, Check .....	15-5-I
Park/Neutral Position <A/T> .....	Refer to P	VEHICLE SPEED SENSOR	
Pop-up .....	54-109-II	ECS .....	33B-18-I
Position Detection .....	33B-19-I	On-vehicle Inspection .....	13A-117, 119, 231, 233-I
Power Steering .....	Refer to P	VENTILATION .....	55-3-I
Rear Window Defogger .....	54-203-II	SYSTEM, Positive Crankcase .....	17-56-I
Stop Light .....	33B-19-I	VALVE, Positive Crankcase .....	17-56-I
<b>T</b>		VENTILATORS (Air Inlet and Air Outlet) .....	55-52-I
TAPE PLAYER		(Instrument Panel) .....	55-50-I
ANTI-THEFT SYSTEM .....	54-156-II	VOLUME AIR FLOW SENSOR	
THEFT-ALARM SYSTEM .....	54-205-II	Engine and Emission Control .....	17-65-I
THERMOSTAT .....	14-9-I	On-vehicle Inspection .....	13A-85, 212-I
THROTTLE BODY .....	13A-288-I	<b>W</b>	
THROTTLE BODY (Throttle Valve Area), Cleaning ...	13A-57-I	WASHER	
THROTTLE POSITION SENSOR .....	33B-19-I	Rear .....	51-28-I
Adjustment .....	13A-57-I	Windshield .....	51-25-I
On-vehicle Inspection .....	13A-98, 221-I	WATERPROOF FILM, Door .....	42-42-I
TIE ROD END BALL JOINT .....	37A-6-I	WATER PUMP .....	14-11-I
TIMING BELT .....	11-31-I	WEATHERSTRIP, Drip Line .....	42-63-I
Maintenance .....	00-46-I	WHEEL .....	31-4-I
TIRE .....	31-4-I	ALIGNMENT	
TRAILING ARM		Front .....	33A-6-I
<AWD> .....	34-32-I	Rear	
<FWD> .....	34-11-I	<AWD> .....	34-25-I
TRANSAXLE		<FWD> .....	34-5-I
<A/T> .....	23-64-I	BEARING	
<M/T AWD> .....	22-19, 23-I	Adjustment .....	33A-6-I
<M/T FWD> .....	22-9-I	End Play Check <FWD> .....	27-3-I, 34-6-I
Automatic, Maintenance .....	00-49-I	WHEEL SPEED SENSOR <ABS> ..	35-113-I
Manual, Maintenance .....	00-48-I		
CONTROL			
<A/T> .....	23-55-I		

Output Voltage Measurement . . . . . 35-75-I  
WINDOW GLASS . . . . . 42-26-I  
  Door, Adjustment.. . . . 42-12-I  
  Quarter . . . . . 42-34-I  
WINDSHIELD . . . . . 42-29-I  
WASHER . . . . . 51-25-I  
WIPER . . . . . 51-25-I

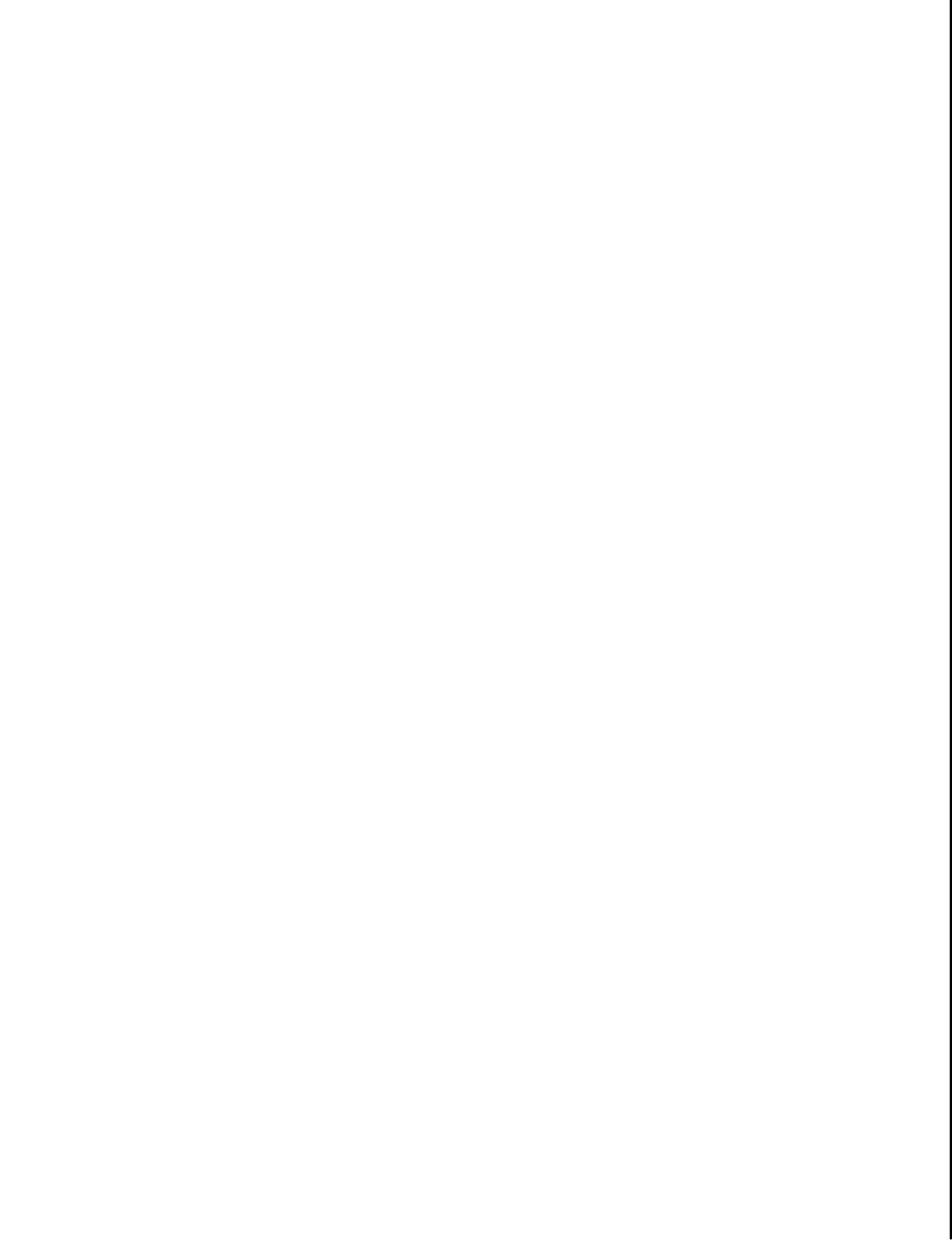



<b>00</b> General	Engine code		6G72	6G72		
	Engine size		cm <sup>3</sup> (cu.in.)	2,972 (181.4)	2,972 (181.4)	
	Engine oil capacity (total)	<Non-Turbo>	dm <sup>3</sup> (qts.)	4.3 (4.5)	4.3 (4.5)	
		<Turbo>	dm <sup>3</sup> (qts.)	4.6 (4.9)	4.6 (4.9)	
	Cooling system capacity		dm <sup>3</sup> (qts.)	8.0 (8.5)	8.0 (8.5)	
	A/T capacity		dm <sup>3</sup> (qts.)	7.5 (7.9)	7.5 (7.9)	
	Power steering capacity	<2WS>	dm <sup>3</sup> (qts.)	0.9 (.95)	0.9 (.95)	
		<4WS>	dm <sup>3</sup> (qts.)	1.5 (1.59)	1.5 (1.59)	
	Rear axle gear oil capacity <AWD>		dm <sup>3</sup> (qts.)	1.1 (1.2)	1.1 (1.2)	
<b>11</b> Engine	Firing order		1-2-3-4-5-6	1-2-3-4-5-6		
	Compression pressure	<Non-Turbo>	kPa (psi)	min. 980 (139)	min. 980 (139)	
		<Turbo>	kPa (psi)	min. 810 (115)	min. 810 (111.5)	
	Difference between cylinders		kPa (psi)	100 (14)	100 (14)	
<b>13</b> Fuel	Fuel tank capacity		dm <sup>3</sup> (gals.)	75 (19.8)	75 (19.8)	
	Fuel pressure					
		(When vacuum hose disconnected)	<Non-Turbo>	kPa (psi)	330 - 350 (47 - 50)	330 - 350 (47 - 50)
			<Turbo>	kPa (psi)	295 - 315 (43 - 45)	295 - 315 (43 - 45)
		(When vacuum hose connected)	<Non-Turbo>	kPa (psi)	Approx. 270 (38)	Approx. 270 (38)
		<Turbo>	kPa (psi)	Approx. 235 (34)	Approx. 235 (34)	
	Basic ignition timing			5° BTDC ± 2°	5° BTDC ± 3°	
	Curb idle speed		rpm	700 ± 100	700 ± 100	
	TPS voltage		mV	400 - 1000	400 - 1000	
	TPS resistance		kΩ	3.5 - 6.5	3.5 - 6.5	
	Intake air temperature sensor resistance		kΩ [at 20°C (68°F)]	2.7	2.7	
Engine coolant temperature sensor resistance		kΩ <20°C (68°F)>	2.4	2.4		
		kΩ <80°C (176°F)>	0.3	0.3		
<b>14</b> Cooling	Radiator pressure cap opens		kPa (psi)	65 (9.2)	65 (9.2)	
<b>23</b> A/T	Fluid capacity		dm <sup>3</sup> (qts.)	7.5 (7.9)	7.5 (7.9)	
<b>26</b> Front Axle	Drive shaft nut torque		Nm (ft.lbs.)	200 - 260 (145 - 188)	200 - 260 (145 - 188)	
	Caliper assembly mounting bolt torque		Nm (ft.lbs.)	90 (65)	90 (65)	
<b>27</b> Rear Axle	Wheel bearing nut torque <FWD>		Nm (ft.lbs.)	200 - 260 (145 - 188)	200 - 260 (145 - 188)	
<b>31</b> Wheel and Tire	Tire inflation pressure	<Front>	kPa (psi)	220 (32)	220 (32)	
		<Rear>	kPa (psi)	200 (29)	200 (29)	
<b>33A</b> Front Suspension	Front wheel alignment	<Camber>		0° ± 30'	0° ± 30'	
		<Caster>		3°55' ± 30'	3°55' ± 30'	
		<Toe-in>	mm (in.)	0 ± 3 (0 ± .12)	0 ± 3 (0 ± .12)	
<b>34</b> Rear Suspension	Wheel bearing nut torque <FWD>		Nm (ft.lbs.)	200 - 260 (145 - 188)	200 - 260 (145 - 188)	
<b>35</b> Brakes	Front disc runout	<FWD>	mm (in.)	0.07 (.0028) or less	0.07 (.0028) or less	
		<AWD>	mm (in.)	0.10 (.004) or less	0.10 (.004) or less	
	Front disc minimum thickness	<FWD>	mm (in.)	22.4 (.881)	22.4 (.881)	
		<AWD>	mm (in.)	28.4 (1.118)	28.4 (1.118)	
	Rear disc runout	<FWD>	mm (in.)	0.08 (.0031) or less	0.08 (.0031) or less	
		<AWD>	mm (in.)	16.4 (.645)	16.4 (.645)	
Rear disc minimum thickness	<AWD>	mm (in.)	18.4 (.724)	18.4 (.724)		
Rear drum inside diameter, max.		mm (in.)	169 (6.653)	169 (6.653)		
<b>36</b> Parking Brakes	Parking brake lever stroke			3 - 5 notches	3 - 5 notches	
<b>51</b> Exterior	Wiper blade length	<Driver's side>	mm (in.)	525 (20.7)	525 (20.7)	
		<Passenger's side>	mm (in.)	500 (19.7)	500 (19.7)	
<b>55</b> Heater, A/C, Ventilation	Refrigerant quantity	<Vehicles using R-12 refrigerant>	g (oz.)	960 (34)*1 or Approx. 800 (29)*2	Approx. 800 (29)	
		<Vehicles using R-134a refrigerant>	g (oz.)	—	740 - 790 (26 - 28)	

NOTE  
\*1: Up to Sept. 1992 models  
\*2: From Oct. 1992 models