



CARTER AFB SELECTION AND TUNING GUIDELINES

Federal-Mogul Document #1601

SELECTING THE CORRECT CARBURETOR SIZE

The Carter AFB is offered in a range of sizes, from 500CFM to 750CFM. CFM stands for “cubic feet per minute”. This is a measure for the amount of air that will flow through the carburetor at wide open throttle while a specified amount of vacuum is maintained below the throttle plate. (Four barrel carburetors are rated at 1-1/2” of vacuum). Each AFB is flexible enough to cover a wide range of engine sizes due to the flow sensing secondary air valves. Even when the secondary throttle plates are open, these air valves will not permit flow through them until the engine is able to handle the additional air and fuel. This prevents “bog” and hesitation during acceleration.

There is no magic formula for determining the correct size carburetor for each application. Different carburetor sizes may produce similar maximum horsepower, but will vary considerably in low speed and midrange performance. These variations will affect vehicle driving performance, particularly in street driven applications. The key is airflow velocity through the carburetor, which produces a vacuum signal to draw fuel through the main boosters. Too large a carburetor will not generate sufficient vacuum to start the main circuit until reaching a high RPM level. When the throttle is open, main circuit fuel flow must begin before the accelerator pump shot is consumed to prevent an engine hesitation or “bog”.

Below is a data chart giving the calculated air flow requirements for a number of engine displacements. If you are selecting a carb for street use, be conservative on size. If your vehicle is modified with a high stall speed converter and a 3.90 or greater gearing, it is usually safe to go to a larger size carb. Large displacement engines, or those operating at high RPM, may benefit from a dual quad setup using two lower CFM carbs on an aftermarket intake.

C.I.D.	ENGINE RPM								
	2500	3000	3500	4000	4500	5000	5500	6000	6500
231-239	165	195	230	260	295	325	360	390	425
252-265	180	215	255	290	325	360	400	435	470
267-283	200	240	280	320	360	400	440	475	520
289-307	220	260	305	350	390	435	475	520	565
318-340	235	280	330	375	425	470	520	565	610
348-360	255	305	355	405	455	505	560	610	660
383-390	270	325	380	435	490	545	600	650	705
396-400	290	350	405	460	520	580	635	695	750
409-429	310	370	430	490	555	615	675	740	800
440-460	325	390	455	520	585	650	715	780	845

← CFM →

Warning - Before installing a Carter Competition series AFB carburetor or other performance products, check your state and local laws as installation may not conform to regulations in some areas. Not legal for sale or use in California on pollution controlled motor vehicles. No products listed here are applicable to aircraft usage. Use only those products designated Marine on Marine applications.

CARTER AFB SELECTION AND TUNING GUIDELINES - Cont'd

TUNING - JETS, METERING RODS, AND SPRINGS

The Carter AFB, as manufactured, has a universal fuel delivery curve that allows it to perform well on a wide variety of applications. While the AFB will work well if simply “bolted on”, the best results are achieved by optimizing the carburetor to the specific engine and vehicle. Federal-Mogul offers all the components needed to fine tune the carb to any application. Carter carburetors are easier to work on, and have more tuning flexibility than do competitive make.

All AFB carburetors have four metering jets. The jets in the secondary side are smaller than those in the primary. The larger primary jets are restricted by metering rods that control the part throttle mixture. Each metering rod has both a large and a small diameter machined step. These steps limit the amount of fuel that flows through the jet. The smaller diameter is at the bottom of the rod, and controls wide open throttle fuel delivery. The upper diameter step limits part throttle fuel flow. The rod is held in a given position within the jet by a calibrated spring, which moves the rod between the steps in response to engine vacuum. Different springs are available, and can be used to alter the enrichment point as a cure for a transitional sag or flat spot, or to compensate for performance camshafts having low manifold vacuum.

Wide open throttle fuel mixture is determined by “reading” the spark plug or by comparing drag strip trap speeds. The mixture is changed by using larger or smaller jets on the secondary side of the carb, and by changes to either the jets or the metering rods on the primary side. Jet changes affect both wide open throttle fuel delivery and part throttle performance, while the metering rods can alter one without significantly affecting the other.

The metering rod design of the AFB lends itself well to the trial and error tuning common to high performance vehicles. Fuel curve recalibration takes only minutes without spilling a drop of fuel, scraping and changing gaskets, or disconnecting fuel lines. Changing the metering rods to ones having a smaller lower diameter and an unchanged upper diameter will richen wide open throttle while retaining the same midrange economy. To do this with other carburetors you will need to remove the float bowls and metering blocks, and drill out the power valve channel restrictions. With the AFB this is done without even taking the top off the carburetor!

All Carter AFB's feature mechanical secondaries, which will guarantee that they open when you floor the gas pedal. To eliminate any bogs or hesitations as the secondaries open, a secondary velocity valve is used. This valve allows airflow through the secondaries in response to engine requirements. The opening rate of this valve can be altered by drilling through the counterweight, but this is rarely necessary. It is also possible to eliminate some secondary bog conditions by removing the small tubes that restrict the “early feed” fuel supplies at the edge of the velocity valve. This modification requires removal of the secondary cluster assemblies, and like drilling the counterweight, it is not usually necessary.

The accelerator pump circuit controls throttle response and off idle acceleration. Too little pump shot will create a flat spot or hesitation, while too much will result in sluggish acceleration and possible black smoke from the exhaust. Federal-Mogul offers a kit with three pump squirters to fine tune this fuel delivery. Additional tuning is done by changing the position of the pump link in the pump arm, and by altering pump stroke. These three adjustments allow you to vary the amount of fuel, the duration of the pump “shot” and the timing of its delivery.

The AFB is manufactured with two .101” diameter needle and seat assemblies. The 10-201 Strip Kit also includes variations with diameters of .111” and .120”. While the larger ones offer more total flow potential, they do so at the cost of some fuel control capability. The .111” size is the largest that is practical for normal street use. All AFB's are calibrated for use with 5 PSI fuel pressure.

The Carter AFB is the carb that powered the Hemi and the Dual Quad 409. It will deliver the trouble free power you need, whether you simply bolt it on and go, or decide to “max it out” for ultimate performance.



INTRODUCTION

All AFB Carburetors are not alike, yet they all share the same basic principles of how they mix air and fuel. Understanding how your AFB works will be a key factor in your carburetion needs being satisfied by the AFB you are installing.

This fine tuning manual reviews the specific circuits of the AFB, it also teaches you how to service the unit and provides step by step procedures in rebuilding the unit.

Included are general instructions for the removal of your old carburetor and the installation of your new AFB. Described are the components necessary for its adaptation to General Motors, Ford and Chrysler vehicles.

Understanding that your vehicle is unique to your driving habits and that the AFB is universal in design, you are responsible to fine tune this carburetor.

For that reason we have included fine tuning information, base calibrations of the AFB line and a metering rod and jet chart all designed to dial in your carburetor to your engines demands. Also provided is a calibration log for recording how your vehicle performed with the changes you tried.

If you need further assistance you can contact our technical assistance phone line at 1-900-555-2900. The charge for this service is \$.50 for the first minute and \$2.00 for every minute thereafter. Our carburetion experts can assist you in fine tuning and trouble shooting your new AFB. The technicians at this number have information and knowledge relating to all of the older Carter AFB and AVS carburetors.

INDEX

AFB Carburetor Description	2
Float Circuit	3
External Bowl Vent	5
Low Speed Circuit	6
High Speed Circuit	8
Auxiliary Air Valve Operation	10
Secondary Initial Discharge	10
Accelerator Pump Circuit	11
Choke Circuit	12
Electric Choke	13
Fast Idle	14
Unloader	14
Disassembly - Cleaning - Reassembly	15
AFB Exploded Diagram	17
Adjustments and Specifications	18
Installation	24
Manual Choke Cable	26
Electric Choke Installation	27
Installation - General Motors	28
Installation - Chrysler Corporation	29
Installation - Ford Motor Company	30
Throttle & Cruise Control Connections	31
Carter AFB Tuning Specifications	32
Base Calibrations	35
AFB Carburetor Calibration Chart	36
Carter AFB Calibration Log	37
Carburetor Trouble-Shooting Information	38

AFB CARBURETOR DESCRIPTION



PART NO.	CFM	APPLICATION
9502	500	Universal Linkage, Chokeless, Non-Emission
9503	500	Universal Linkage, Manual Choke, Non-Emission
9504	500	Universal Linkage, Electric Choke, Emission Calibrated
9605	600	GM Linkage, Manual Choke, Non-Emission
9606*	600	Chrysler Linkage, Manual Choke, Non-Emission
9607*	600	Ford Linkage, Manual Choke, Non-Emission
9635	625	GM Linkage, Electric Choke, Emission Calibrated
9636	625	Chrysler Linkage, Electric Choke, Emission Calibrated
9637	625	Ford Linkage, Electric Choke, Emission Calibrated
9638*	625	GM Linkage, Electric Choke, Emission Calibrated, E-Coat
9755	750	GM Linkage, Manual Choke, Non-Emission
9756*	750	Chrysler Linkage, Manual Choke, Non-Emission
9757*	750	Ford Linkage, Manual Choke, Non-Emission
9641	625	Marine, Universal Linkage, Electric Choke
9758	750	Marine, Universal Linkage, Electric Choke

The Carter AFB carburetor is rich in the history of performance automobiles. First introduced in 1957, it was used on such legends as the Chevy 409", Chrysler 426" Hemi, 1959 Ford Thunderbird, and the Studebaker Avanti. The AFB you have just purchased is a continuation of that tradition. It has been engineered to be universal in nature, though the carburetor's calibration is easily adjusted for many O.E. AFB applications.

The Carter AFB ("Aluminum Four Bore") is unique in carburetor design; the main body and flange are cast as one unit. This, along with the bowl cover, make up a two piece construction which is light weight, and dissipates heat. Also there are no gaskets below fuel level that can leak fuel onto the engine.

All AFB series with electric choke weigh approximately 7 lbs. 2 oz., while those with manual chokes (or chokeless) weigh approximately 6 lbs. 12 oz. The height is 3-7/32" from base to air cleaner gasket surface and uses an air cleaner with a 5 1/8" dia. opening.

Throttle bore spacing is for a "square bore" intake manifold. On vehicles incorporating a "spread bore" intake manifold, a Carburetor Adapter Plate (**CARTER #9600A**) should be used to prevent manifold vacuum leakage, and allow room for the throttle valves to open.

WARNING: BEFORE INSTALLING A CARTER AFB SERIES CARBURETOR, CHECK YOUR STATE AND LOCAL LAWS. ALTHOUGH SOME MODELS ARE EMISSION-CALIBRATED, INSTALLATION MAY NOT CONFORM TO REGULATIONS IN SOME AREAS. NOT LEGAL FOR SALE IN CALIFORNIA ON POLLUTION CONTROLLED VEHICLES. NOT APPROVED FOR MARINE APPLICATIONS UNLESS SO STATED. NOT APPROVED FOR AIRCRAFT, PROPANE CONVERSION ENGINES OR BLOW THROUGH SUPERCHARGERS.

Five conventional circuits are used in the 9000 Series AFB. They are:

- 1) Two float circuits
- 2) Two low speed circuits
- 3) Two high speed circuits
- 4) One accelerator pump circuit
- 5) One choke circuit

* Discontinued Part Number No Longer Available.

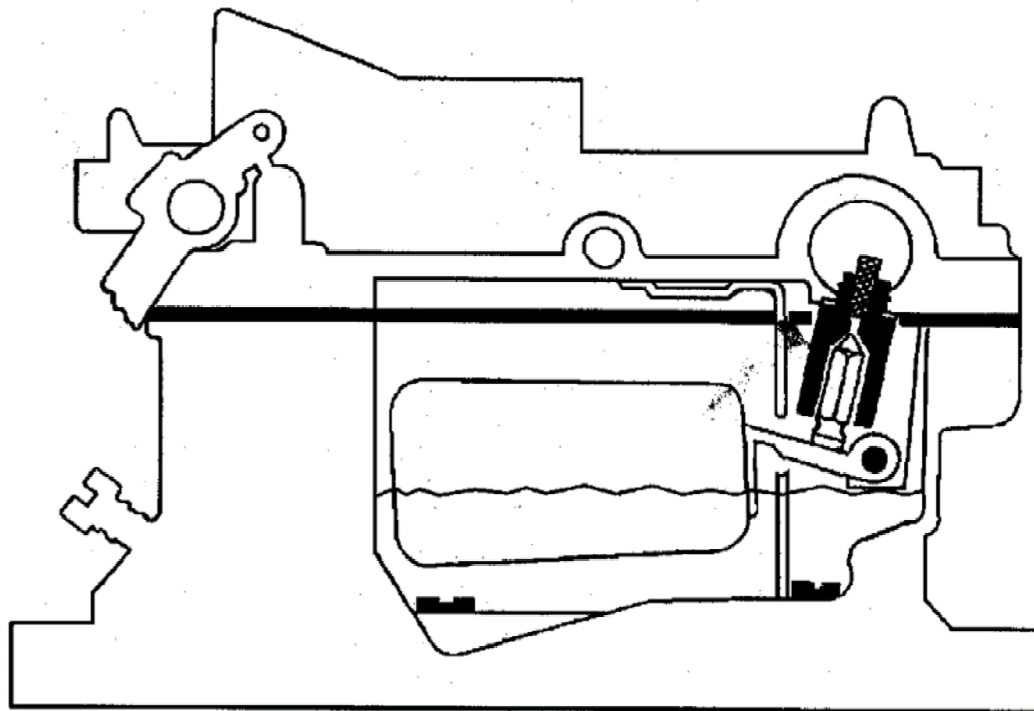

The purpose of the float circuit is to maintain an adequate supply of fuel at the proper level for use by the low speed, high speed, accelerator pump and choke circuits.

There are two separate fuel bowls and float circuits. Each supplies fuel to a primary low speed circuit and a primary and secondary high speed circuit.

Baffles are used in the bowls to provide a stable fuel supply for the primary and secondary main jets.

The bowls are vented to the inside of the air horn and on certain models to the atmosphere. A connecting vent passage provides a balance of air pressure between the two bowls. Bowl vents are calibrated to provide proper air pressure above the fuel at all times.

Setting the brass **Floats (CARTER #21P-188)** to specification assures an adequate supply of fuel in the bowls for all operating conditions.

The intake needle seats are installed at a 15° angle from the vertical position to provide the best possible seating action of the intake needles and response to float movement.

For "off-road" applications and vehicles with stiff suspensions, **Spring Loaded Needle/Seats (CARTER #25P-965S)** are recommended. These reduce the possibility of flooding and richness, by stabilizing the fuel level.

TROUBLE SHOOTING THE FLOAT CIRCUIT



In servicing the carburetor, it is important to service the lip of the float which must be smooth for proper action and fuel level control. A small groove or indentation will probably be found on the lip from contacting the needle. Use a strip of emery cloth about 1/4" wide and hold the abrasive side to the float lip. Place thumb on the cloth where it passes over the lip, and while pressing with the thumb, pull the emery cloth through until a new contact surface on the float lip is attained.

Examine the float for dents. A dented float will sink deeper into the fuel (less buoyant) which will raise the fuel level. Replace all dented floats. Check the float to determine if it is "loaded with gas". Sometimes shaking the float allows one to hear the fuel splash inside. A float loaded with gas must be replaced. Submerge floats in warm water to check for leaks (air bubbles will be visible issuing from the leak.)

Float adjustment for proper fuel level in the bowl is important. Low or high settings affect the transfer point from the low speed circuit to the high speed circuit as the throttle is opened.

A high float setting can result in flooding, stalls on brake stops, and/or turns. While a low float setting could cause a hesitation in a drive away, should the jet become uncovered, and "Dry Bowl" morning starts.

Proper float drop adjustment is also important. Too much float drop allows the inlet needle to drop far from the needle seat which may cause the needle to bind. This results in flooding as the float will not be able to seat the needle.

Special consideration should be given during service to be sure the floats do not bind in their hinge pin brackets or drag against the inner wall of the bowl. You may wish to polish the location of the float pin holes on each float with a fine crocus cloth. This will remove any burrs which may hinder the movement of the float.

Extremes in fuel pressure should be avoided. At IDLE speed, fuel pressure should not exceed 6.0 psi; if an adjustable fuel-pressure regulator is in use, set it to 5.5 psi. With most fuel pumps the minimum fuel pressure is encountered at high rpm and wide open throttle. Fuel pressure should not drop below 2.0 psi. If it does, a fuel pump with more capacity may be required.

The carburetor bowl and the intake strainer screen(s) should be clean and free of dirt, gum or other foreign matter. To assure a positive seal, the gasket surface of the castings must be free of nicks and burrs. An air leak at these points can result in a mileage complaint and cutting out on sharp turns or sudden stops. Use of a new **Fuel Bowl/Airhorn Gasket (CARTER #121P-951)** and proper tightening of the cover screws is a must. A leak at the bowl cover would cause an increase in the pressure in the bowl, resulting in a rich mixture. If the vehicle you are using an AFB on is stored for long periods, a fuel stabilizer is recommended to prevent sour gas buildup on the floats and needle/seats.



EXTERNAL BOWL VENT

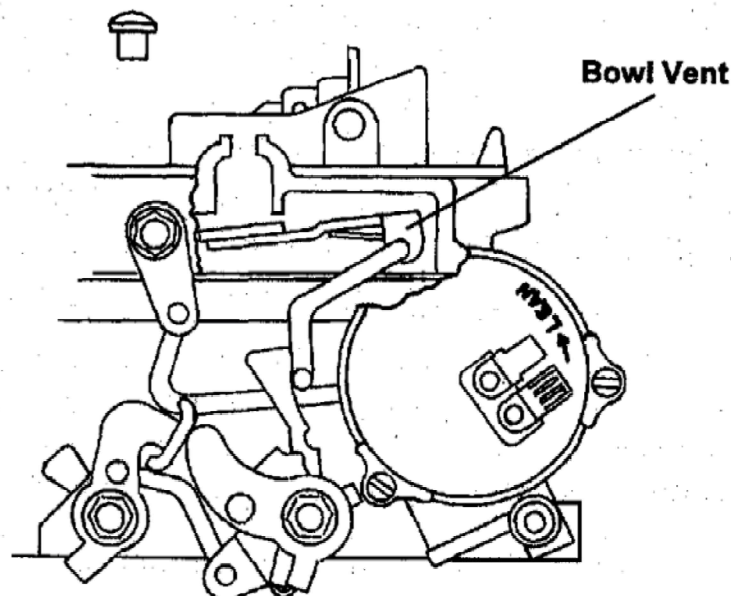

The AFB series emission calibrated carburetors use a combination of a mechanically operated internal and external vents. The non-emission calibrated and marine carburetors use an internal vent only.

Venting of the fuel bowl is also important. Air must enter or leave the bowl every time the level of fuel changes in the bowl. The AFB internal vents are located next to the step-up piston cylinders on each side of the unit.

During vehicle acceleration the gasoline level in the bowl is lowered. This causes the float to drop allowing the needle to come off its seat so that gasoline can enter the bowl. The increased space (above the liquid) caused by the lowering of the fuel level must be filled with air in order to maintain a constant pressure in the bowl. This is the purpose of the bowl vent. During constant throttle operation, the amount of fuel entering the bowl is the same as the amount being discharged from the low speed or high speed circuit.

All above-idle engine operation is done with the inside vent only. With this type vent, the pressure in the fuel bowl and inside the carburetor air horn are the same. In other words, a balance is effected between the pressure in the air horn and the pressure in the bowl. This prevents a rich condition should the air cleaner become restricted. A restricted air cleaner with this type of venting will not change the air/fuel ratio. However, it will affect volumetric efficiency due to reduced air flow.

When the engine is turned off, or at idle, underhood temperatures increase causing vapors to rise from the fuel in the bowl. The outside vent improves hot starting characteristics as it prevents vapors from entering the bore of the carburetor.

Emission Laws effective in 1971 required all external vents to be routed to a canister to prevent evaporative emissions from entering the atmosphere.

External bowl vent adjustments must be to specification. If a valve doesn't open to specification when the throttle valves are closed, bowl vapors cannot escape freely and may cause "hard hot-starting". If it opens too far, or hangs open, it will allow an external vent to the bowl, resulting in poor mileage. **DO NOT CAP THE BOWL VENT.**

LOW SPEED CIRCUIT



Fuel for idle and early part throttle operation is metered through the jets in the low speed circuit. The low speed circuit is located on the primary side only. Gasoline enters the idle wells through the main metering jets.

The diagram at right illustrates a Five Point Circuit: ① Low Speed Jet; ② By-Pass;

③ Economizer; ④ Idle Bleed and

⑤ Idle Port. Following this circuit

downstream, the first entrance of

air is at the By-Pass. The air and fuel

mixture is "squeezed" through the

Economizer and ejected into the

lower pressure area which speeds

up the flow and further mixes the

air and gasoline. Following down-

stream is the second entrance of

air, at the Idle Bleed, and then to

the Idle Port. The low speed, by-

pass, economizer and idle bleed are located in the primary venturi cluster.

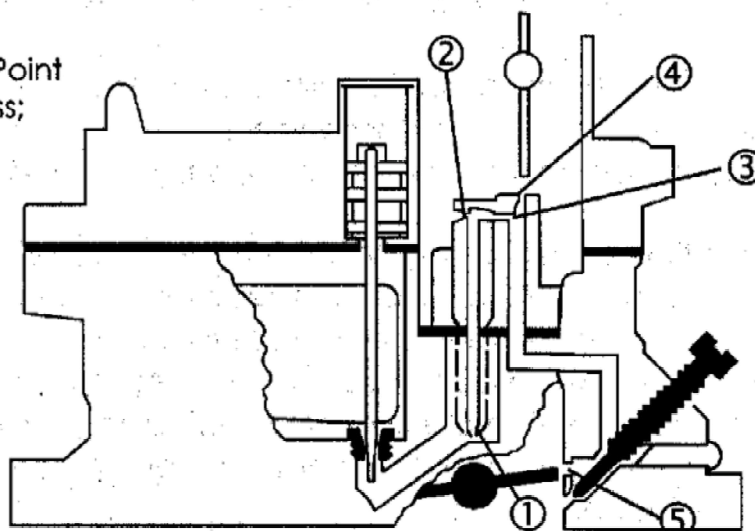

Tiny air bubbles enter the idle stream through the air bleeds, aerating the fuel before it reaches the idle port and helping the fuel mix more readily and uniformly. This system is designed to produce "sonic" flow, so that small changes in manifold vacuum do not change the idle mixture.

The **quality** of the mixture is determined by the size of the idle jet, the by-pass and idle bleed. The **quantity** of the mixture to the idle port is adjusted by the idle adjusting screws.

The idle adjusting screws are used for trimming the idle mixture to individual engine requirements. Turning the idle adjustment screws towards their seat reduces the quantity of air/fuel mixture supplied by the idle circuit. This is an over-rich mixture that emerges from the port, but is leaned to a proper combustible mixture by the air that enters the intake manifold around the "cracked" primary throttle valve. Consequently, rotating the idle adjusting screws inward (clockwise) leans the idle mixture, while rotating them outward (counter-clockwise) enriches the idle mixture.

NOTE: When first setting up your carburetor, you should record how many turns your idle adjustment screws are from seat. Do this by rotating the screws clockwise, counting the number of turns to seat. **DO NOT FORCEFULLY SEAT THE IDLE ADJUSTMENT SCREWS.** Return the adjustment screws back to their original pre-set position by re-counting the number of turns from seat. Both idle adjusting screws should be set equal amount of turns from seat. Two idle adjustment screws and springs are available in **Carter #30-243A**.

The idle ports, located directly above the idle adjusting screws ports, are slot shaped. As the throttle valves are opened, more of the idle ports are uncovered, allowing a greater quantity of the air/fuel mixture to enter the carburetor bores.

Further opening of the throttle causes the throttle valve to move away from the idle port, diminishing fuel delivery to the low speed circuit. The increase in air velocity with throttle opening causes fuel flow to begin from the high speed system. This is known as the transfer point.

A low float setting can cause a problem at the transfer point which will result in the high speed nozzle delivering fuel incorrectly. Float setting plays its part in timing the nozzle.



TROUBLE SHOOTING THE LOW SPEED CIRCUIT

Dirt or foreign material in the economizer will cause a lean idle condition, any obstruction in the by-pass or idle bleed will result in a rich condition.

The by-pass, economizer, idle bleed, idle port, idle adjustment screw port, as well as the bore of the carburetor flange must be clean and free of carbon. Obstructions will cause poor low speed engine operation and a poor idle quality.

Port relation is the position of the throttle valve relative to the idle port at curb idle. Port relation could be out of specification due to carbon in the bore of the carburetor, throttle valves not properly seated, and throttle shaft or throttle-body wear. In any case, it can upset the idle and affect the transfer point. Improper idle adjustment or a high overlap camshaft can upset the port relation. Sometimes a 1/8" diameter hole drilled in each primary throttle valve will return the unit to the proper relation.

The idle adjusting screws can be used to quickly test the low speed circuit on the car. The idle adjusting screws should be sensitive when turning "in" or "out." If turning the mixture screws does not appreciably affect idle, there could be a problem in the low speed circuit. Conversely, if the best idle is attained with the idle mixture screws seated or near the seat, it is indicative of a rich idle mixture. This could be traced to dirt in the by-pass or idle bleed, or both of them partially plugged, or the high speed system feeding through the nozzles due to a high fuel level, or high idle speed.

If the best idle is attained with the idle mixture screws near the outward (counterclockwise) position, it is indicative of a lean idle mixture. This could be the result of dirt or a restriction in the economizer. A good range for setting the idle mixture screws is between 1 1/2 to 3 turns from seat.

The low speed jet, idle bleed, economizer and by-pass bushings are pressed in place. Do not remove when servicing. To insure proper alignment of the low speed mixture passage, the primary venturi assemblies were designed with interlocking bosses so they can only be installed in their proper locations. (When the primary venturi assemblies are placed in the wrong side of the carburetor, they will not fit all the way into the body/flange casting.)

Air leakage at the gasketed surface surrounding the low speed (idle) mixture passages or between the flange and manifold may cause poor idle and low speed operation. Always use new gaskets when servicing the carburetor (**CARTER #902-317A Zip-Kit**).

HIGH SPEED CIRCUIT—PRIMARY SIDE

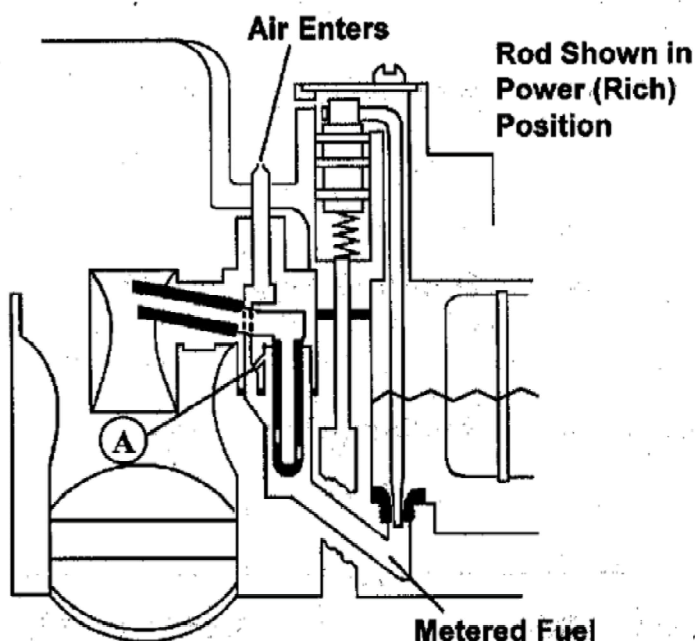

Fuel for part throttle and full throttle operation is supplied by the high speed circuit.

The diameter of the step-up rod in the main metering jet controls the amount of fuel admitted to the nozzles. The position of the step-up rod is controlled by manifold vacuum applied to the step-up piston.

During part-throttle operation, manifold vacuum overcomes the tension of the step-up piston spring and pulls the step-up piston and rod assembly down, holding the large diameter of the step-up rod in the main metering jet. Fuel is then metered around the large diameter of the step-up rod through the jet producing an economy mixture.

During acceleration or under load, when the tension of the spring overcomes the pull of vacuum under the piston, the step-up rod will move up so its smaller diameter, or power (high speed) step, is in the jet. This allows additional fuel to be metered through the jet.

On the underside of the primary venturi cluster is incorporated a crotch bleed (see A in diagram). This bleed prevents a rich condition and bog when the high speed circuit is re-initiated after deceleration.

A vent tube aerates the fuel as it leaves the high speed well.

Both downhill and uphill nozzles have been used, depending on the vehicles calibration.



TROUBLE SHOOTING THE HIGH SPEED CIRCUIT

ROD DOWN: Lean Air Fuel Ratio

WIDE OPEN THROTTLE: Low Vacuum

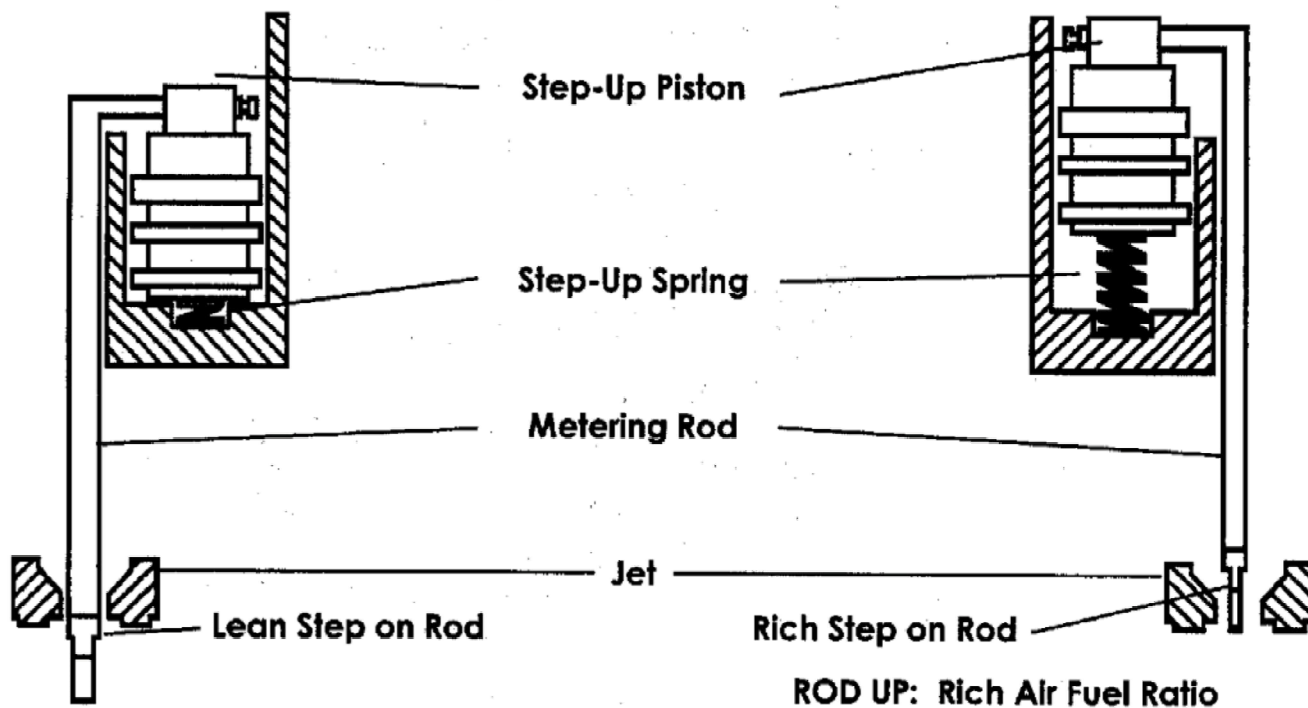

IDLE: High Vacuum

ROD UP: Rich Air Fuel Ratio

The use of wrong step-up piston spring, or one that has been stretched or cut off, can seriously upset carburetor calibration.

A clogged air bleed or main vent tube may cause excessively rich mixtures. The high speed bleed and main vent tubes are permanently installed and should not be tampered with.

An incorrect float setting can also adversely affect high speed circuit operation.

HIGH SPEED CIRCUIT—SECONDARY SIDE

Fuel for the high speed circuit of the secondary side is metered at the main metering jets. No step-up rods are used in this circuit.

On some early applications of AFBs the secondary metering jets are located under the secondary venturi cluster.

Due to the use of step-up rods on the primary side, the primary main metering jets are usually larger than the secondary metering jets.

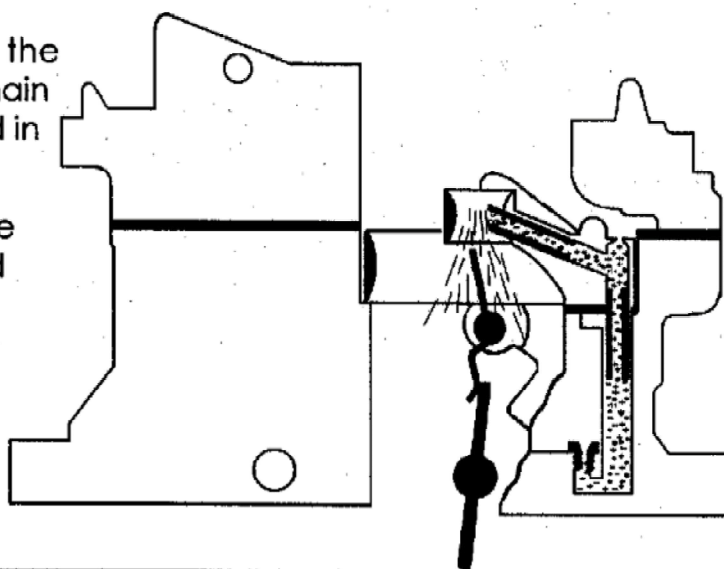

AUXILIARY AIR VALVE OPERATION



The offset valves (see A in Diagram) above the secondary throttle valves are called "auxiliary air valves." Counterweights are located on the ends of the auxiliary valve shaft. The auxiliary valve counterweights operate within a recess inside the carburetor body. Throttle valves in the secondary side remain closed until the primary valves have been opened a predetermined amount. Air velocity through the carburetor controls the position of the auxiliary valves. The auxiliary valves open when the force of the air against the offset valves is able to lift the counterweights. If the valve does not come in quickly enough, holes can be drilled in both sides to lighten the weights and allow the air to more easily pull the valve open. If the valve then comes in too soon split shot lead weights can fill the holes to increase the weight.

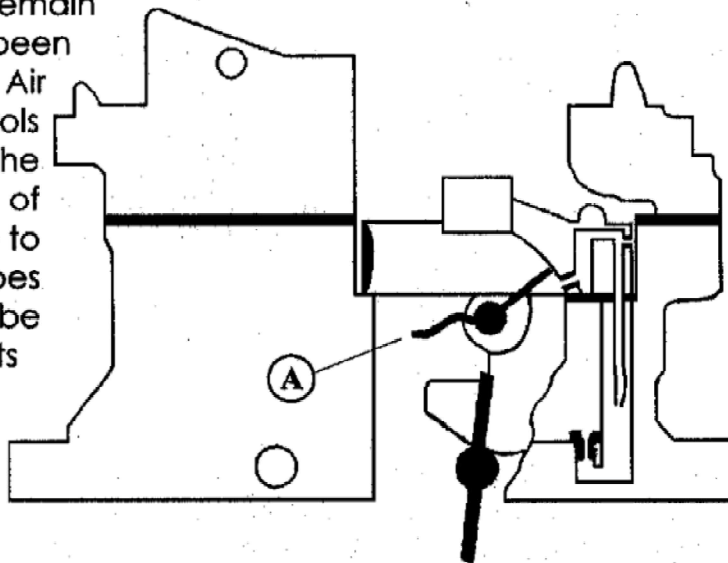

When the accelerator is fully depressed, only the primary high speed circuit will function until there is sufficient air velocity to open the auxiliary valves. When this occurs, fuel will then come from the secondary high-speed circuit.

SECONDARY INITIAL DISCHARGE

Secondary initial discharge ports are incorporated to assist the starting of the fuel flow in the secondary high speed circuit. These ports are located next to the venturi struts. When the auxiliary valves start to open, the vacuum at the discharge ports pulls fuel into the pick-up tubes. Air bleeds serve to break-up the liquid fuel and mix it with air as it moves through the passages to the initial discharge ports where it is discharged. As the auxiliary valves continue to open, and secondary nozzles deliver additional fuel, less fuel flows from the initial discharge ports.

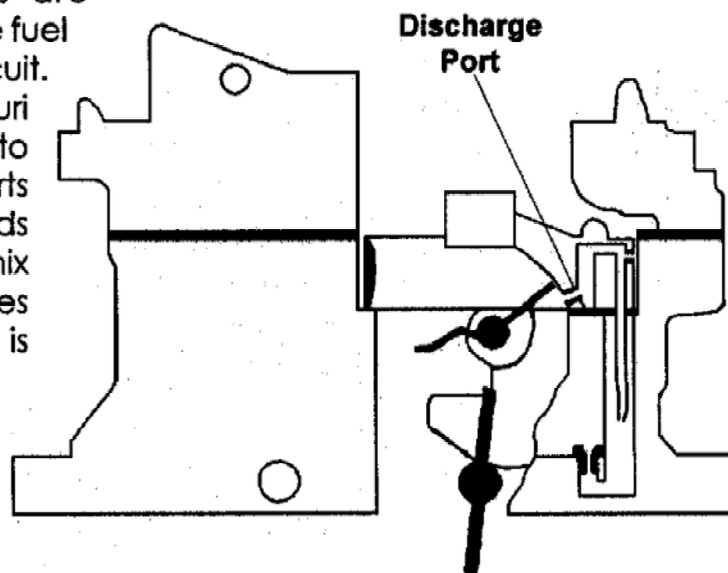



ACCELERATOR PUMP CIRCUIT

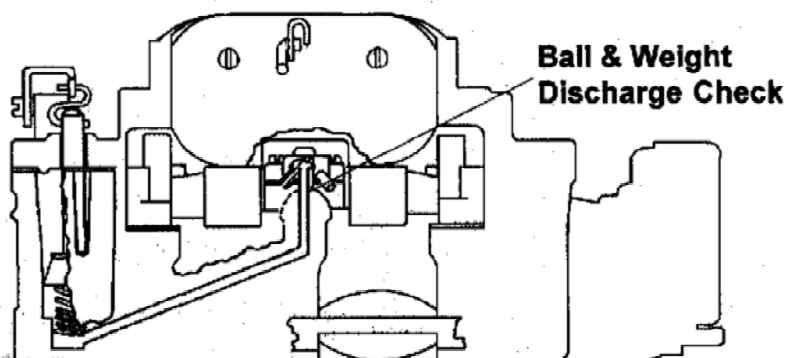

When the throttle is closed, the **Accelerator Pump Plunger (CARTER #64P- 398 or 64P-399)** moves upward in its cylinder and fuel is either drawn through the intake check or past the pump plunger cup. **NOTE: Earlier versions of the AFB contain an intake check; newer versions do not.** The discharge check is seated at this time to prevent air being drawn into the cylinder. When the throttle is opened, the pump plunger moves downward forcing fuel out through the discharge passage, past the discharge check, and out of the pump jets (shooters). When the plunger moves downward, the intake check is closed, or the floating cup seated, preventing fuel from being forced back into bowl.

At higher vehicle speeds, the pump discharge is no longer necessary to insure smooth acceleration. When the throttle valves are opened a predetermined amount, the pump plunger bottoms in the cylinder eliminating pump discharge. To prevent discharge through the discharge ports at high speeds, a brass check needle is used. The weight of the needle also prevents pump pull-over.

TROUBLE SHOOTING THE ACCELERATOR PUMP CIRCUIT



Trouble shooting the pump circuit should include a thorough check of the intake (if applicable) and discharge checks, pump plunger, duration spring and all linkage.

If the discharge check is not seating, air will be drawn into the pump circuit during deceleration. On acceleration, air would be discharged before solid fuel is delivered to the pump jet resulting in a stumble or hesitation.

If the intake check is not seating, some of the fuel during acceleration will be returned to the fuel bowl, resulting in lack of fuel for acceleration.

To determine if the checks are seating, proceed as follows: With fuel in the bowl and pump passages, use a suitable tool to hold the discharge check on its seat. While holding the discharge check against its seat, manually raise and lower the pump plunger in its cylinder several times. This will create pressure in the circuit. If fuel leaks into the fuel bowl (noted by bubbles), the intake is leaking.

To test the discharge check, make certain fuel is in the entire circuit. With the discharge check on its seat (by its own weight), squirt gasoline on top of the check and observe. If the fuel does not leak past the check (remains on top) for a period of 30 seconds, then the check is good.

Check condition of pump plunger and pump cylinder wall.

The linkage connecting the pump plunger to the throttle requires an adjustment to obtain the correct pump stroke for proper pump delivery. This adjustment must be made according to specifications listed by the manufacturer.

CHOKE CIRCUIT

The present 9000 series AFB carburetors are equipped with either an electric or manual choke depending on the model number. Both operate using the same linkage configurations, with the differences in their activation and control. The manual choke is controlled through a **Manual Choke Cable (CARTER #9600C)** by the vehicles operator. The electric choke relies on the electrical heating of a bi-metal **Thermostatic Choke Coil (CARTER #170P-1313)**.

Those carburetors equipped with manual choke systems can be converted to electric by obtaining and installing a **Electric Choke Conversion Kit (CARTER #170P-1314)**.

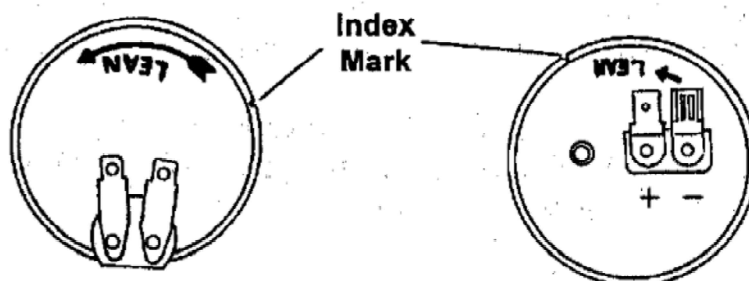

The automatic choke circuit, located in the primary side, provides the correct mixture necessary for quick cold engine starting and warm-up.

Three (3) factors control the operation of the automatic choke. They are:

1. Air velocity
2. Heat
3. Manifold vacuum

Air velocity is used to create a mechanical movement of the choke valve. The choke valve is mounted "off-center" on its shaft. The air velocity against the off-set (long side) opens the valve the proper amount to allow the engine to breathe.

Heat is used to cause mechanical movement of an electrically heated thermostatic coil, which is a bi-metal spring consisting of two dissimilar metals bonded together, and sensitive to changes in temperature. When the spring is cold, it rotates to close the choke valve. As the spring is subjected to heat, it expands and allows the valve to open.

Manifold vacuum is converted to mechanical movement by use of a piston located within a cylinder.

Putting these three factors together, the choke will operate as follows: When the engine is cold, the bi-metal spring is wrapped tight causing the choke valve to be in the closed position. As the engine is cranked, more air striking the long side of the choke valve causes it to open a predetermined amount to allow the engine to breathe. When the engine starts, manifold vacuum is applied to the choke piston, opening the choke valve a predetermined amount to prevent over-rich mixtures.

The thermostatic coil spring is a direct indicator of the engine temperature. As the engine warms up, the thermostatic coil tension decreases allowing the choke valve to open proportionally.

During the warm-up period, the valve is always in a position relative to these three controlling factors.

Acceleration during the warm-up period requires a slightly richer mixture. Acceleration, or throttle valve opening, is always accompanied by some loss of manifold vacuum. Lowering manifold vacuum to the choke piston allows the choke valve to close slightly, giving a richer mixture to meet engine demand.

FAST IDLE



During the warm-up period, it is necessary to provide a fast idle speed to prevent engine stalling. This is accomplished by a fast idle cam (B) connected to the choke linkage. The fast idle adjusting screw (A) on the throttle lever contacts the fast idle cam and prevents the throttle valves from returning to a normal warm engine idle position, while the choke is in operation.

The 625 CFM series are the only AFB carburetors using a secondary throttle lockout to eliminate secondary throttle operation during the choke cycle. The throttle lockout latch is triggered by the fast idle cam.

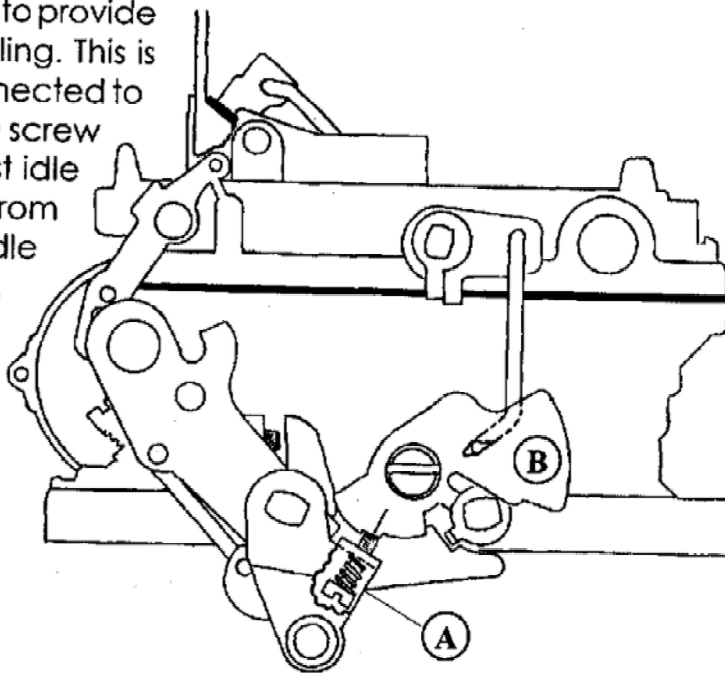

UNLOADER

If during the starting period the engine becomes flooded, the choke valve may be opened manually to clean out excessive fuel in the manifold. This is accomplished by depressing the accelerator pedal to the floor mat and engaging the starter. The unloader projection (A) on the throttle lever contacts the unloader lug (B) on the fast idle cam and partially opens the choke valve (C).

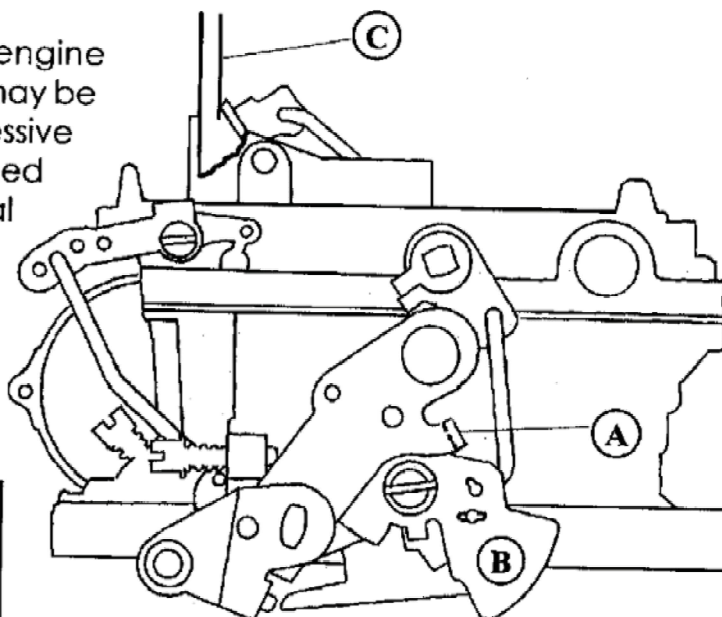

WARNING:
EXTERNAL CARBURETOR
LINKAGES ARE DESIGNED TO
OPERATE DRY AND SHOULD NOT
BE LUBRICATED.

If oil is used, it will attract dirt, become gummy and interfere with correct linkage operation.

NOTE: If AFB linkages are lost or misplaced, a set of seven linkages and six retaining clips are available. **Linkage Assortment (CARTER #115P- 9000)**



TROUBLE SHOOTING THE CHOKE CIRCUIT

The choke cannot affect engine performance until it is running. All electrical and related tune-up work should be done prior to carburetor and/or choke diagnosis.

1. Check all linkage for any binding or sticking. Check the choke valve to make certain it is free and not binding. Over-tightening the air cleaner may cause a warping or binding.
2. Check for air leaks between the choke thermostatic coil and choke housing. A leak in this area will slow the opening of the choke valve.
3. Choke setting, fast idle and unloader adjustment should be to specifications.
4. Check for 12 volts at the choke. Many original equipment electric chokes, especially Ford applications, use less than 12 volt choke systems. Using less than 12 volts with the Carter choke will result in rich choke operation.

DISASSEMBLY, CLEANING, AND REASSEMBLY

Tools you will need:

- Slotted Screwdrivers (Medium & Large Blade)
- T15 & T25 Torx Drivers
- Needle-Nose Pliers
- 3/4" Open-End or Adjustable Wrench
- 3/16, 1/4, & 5/16" Nut Drivers

When rebuilding your 9000 series AFB carburetor use **CARTER ZIP-KIT #902-317A**. This kit contains all of the gaskets, needles/seats, pump plunger and minor components to properly overhaul your carburetor. The inspection and replacement of the float (**CARTER #21P-188 [2 required]**) is necessary for a complete rebuilding.

The numerical sequence of the exploded view may be used as a guide to disassemble the unit far enough to permit the cleaning, inspection and installation of the kit contents. Notice the holes from which the linkage rods are removed so they can be returned to the same locations during reassembly.

Clean all parts in an approved cleaning solvent. Special attention should be given to carbon deposits in the throttle bore and passages. Before reassembly, rinse parts in a suitable solvent and blow out all passages with compressed air. **DO NOT soak plastic, rubber or similar materials in the solvent. DO NOT SOAK CARBURETOR 9638 IN SOLVENT.**

DISASSEMBLY, CLEANING, AND REASSEMBLY (Cont'd)



When reassembling you may reverse the numerical sequence using the reference numbers shown in the exploded view as a guide. Always use a Carter Zip-Kit when rebuilding your carburetor to insure the quality of the replaced parts. Note the following special instructions:

1. Idle mixture screws (43) should be seated lightly and then backed out to their original position or two turns for an initial setting. Refer to the vehicle's service manual for the proper idle and fast idle final adjustments on the engine.
2. The vacuum piston springs (6), step-up piston (5), and metering rod assemblies (3&4) should be installed after the bowl cover (20) has been installed on the body.
3. Mark the primary and secondary venturi assemblies (34 & 30) before removal so they can be reinstalled in their proper location.
4. When installing the bowl cover (20) be sure the fuel baffles slide down the front of the baffle plates (28) in the fuel bowl.
5. Install the open end of the accelerator pump "S" link (14) toward the choke valve. The link should look like the letter "S" form the front of the carb.
6. When installing the bowl cover (20) guide the brass bleed tubes on the primary venturi through the bowl cover holes (if equipped).
7. Apply a light film of lubricant to the cup of the plunger assembly (25) before installing.

Exploded AFB Diagram Labels

1. Cover plate screw	(2)	29. Secondary ventury assy. screw	(4)
2. Cover plate	(2)	30. Secondary ventury assembly	(2)
• 3. Step-up rod	(2)	* 31. Secondary ventury assy. gasket	(2)
4. Step-up retainer spring	(2)	32. Auxillary valves and shaft	
5. Step-up piston	(2)	33. Primary ventury assembly screw	(4)
• 6. Vacuum piston spring	(2)	34. Primary venturi assembly	(2)
* 7. Pin spring	(2)	* 35. Primary venturi assembly gasket	(2)
8. Pump connector rod		36. Pump jet housing screw	(2)
9. Fast idle cam connector rod		* 37. Pump jet housing	
10. Countershaft lever		* 38. Pump jet gasket	
11. Choke connector rod		* 39. Pump discharge check needle; or ball and weight	
12. Pump lever screw		• 40. Primary metering jet	(2)
13. Pump lever		• 41. Secondary metering jet	(2)
14. Pump "S" link		42. Idle mixture screw	(2)
15. Fuel inlet fitting		43. Idle mixture screw spring	(2)
* 16. Fuel inlet fitting gasket		44. Coil housing retainer screw	(3)
17. 3/16" Fresh air choke hose		45. Coil housing retainer	(3)
18. Bowl cover screw	(8)	46. Choke ground wire (black)	
19. Bowl cover screw	(2)	• 47. Coil housing	
20. Bowl cover		* 48. Coil housing gasket	
21. Float pin	(2)	49. Baffle plate	
• 22. Float	(2)	50. Piston housing attaching screw	(3)
* 23. Needle and seat assembly	(2)	51. Piston housing	
* 24. Bowl cover gasket		* 52. Piston housing gasket	
* 25. Plunger assembly		53. Throttle body casting	
26. Lower plunger spring		54. Base gasket	
27. Vent valve			
28. Float bowl baffle	(2)		



AFB EXPLODED DIAGRAM

NOTE: Fuel Inlet may be on either side of Carburetor.

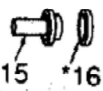
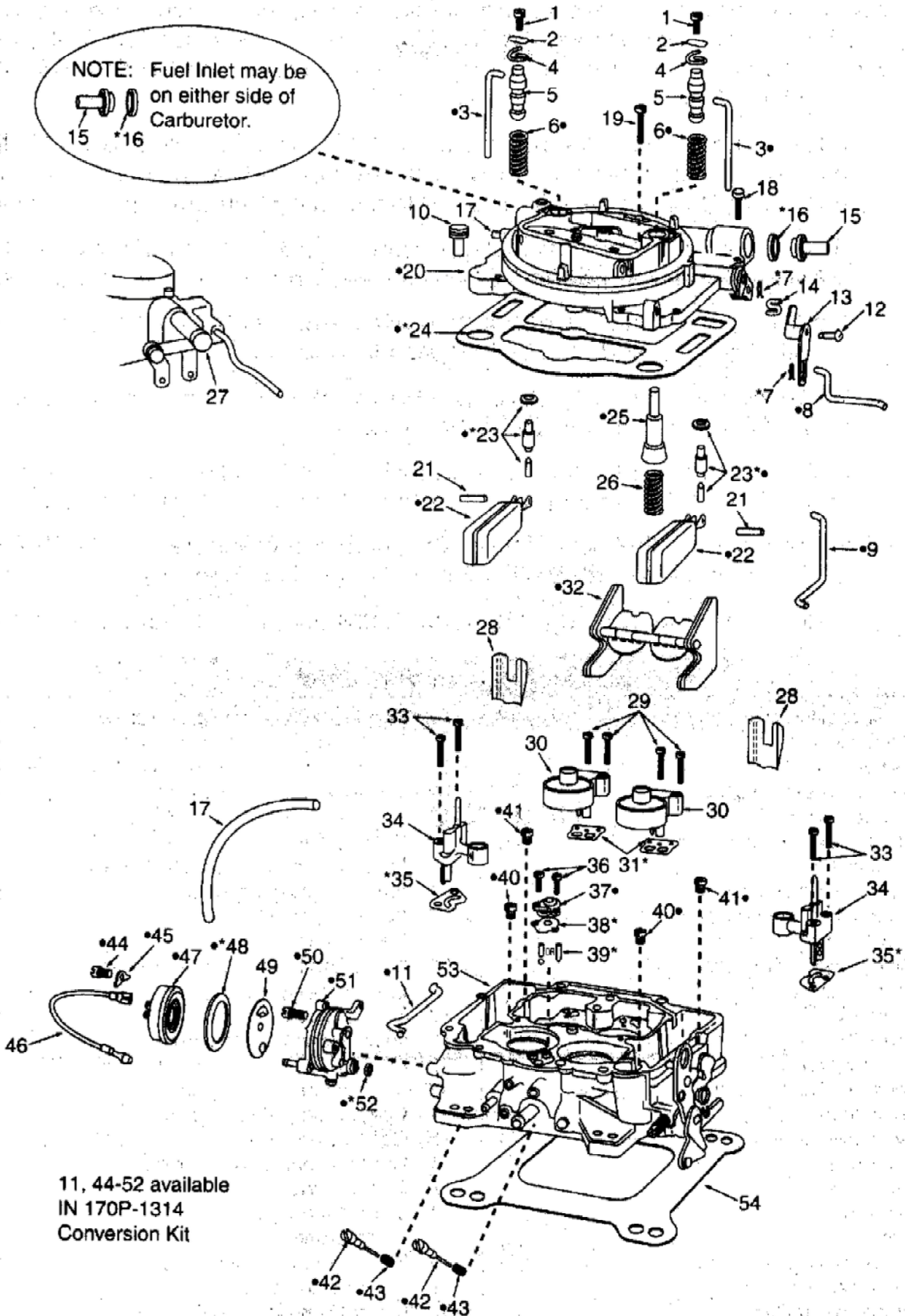
11, 44-52 available
IN 170P-1314
Conversion Kit

- Only these parts can be purchased separately. Refer to Service Parts Catalog for proper application
- ★ Indicates parts contained in Re-Carb Kit.

ADJUSTMENTS AND SPECIFICATIONS



Float Level

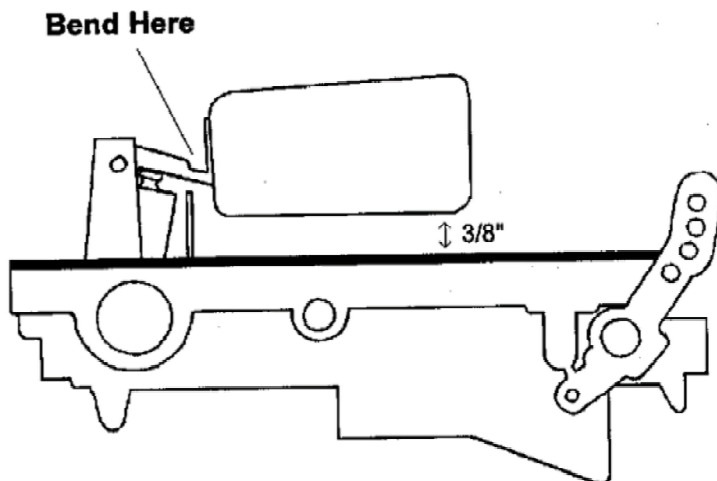

With the bowl cover inverted, bowl cover gasket in place, and weight of float seating on the needle, there should be $3/8$ " between the top of each float and the bowl cover gasket (at the outer end on the seam). The sides of the floats should be parallel to the outer edge of the bowl cover. To adjust, bend the float lever near the pivot pin.

CAUTION:
DO NOT PRESS NEEDLE INTO SEAT WHEN ADJUSTING FLOAT LEVER.

Float Drop

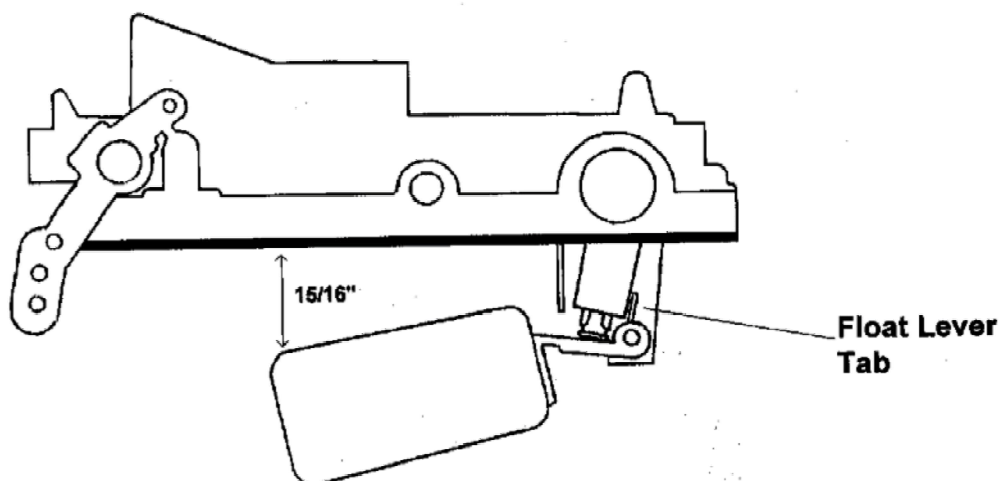

With the bowl cover held in the upright position adjust stop tabs on the float brackets to obtain $15/16$ " between the outer end of each float and bowl cover gasket. To adjust, bend the tab on the float lever.

Accelerator Pump

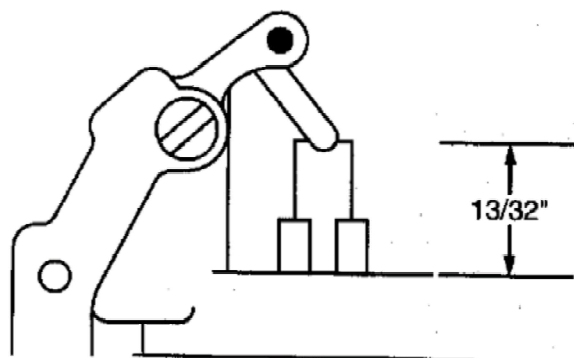

Back out the throttle speed screw (count turns) to allow throttle valves to seat in the bores. Install connector rod in the second from the bottom hole of the pump lever. Adjust rod to obtain $13/32$ " from top of the bowl cover to the top of the plunger stem as shown.

Choke Piston Linkage

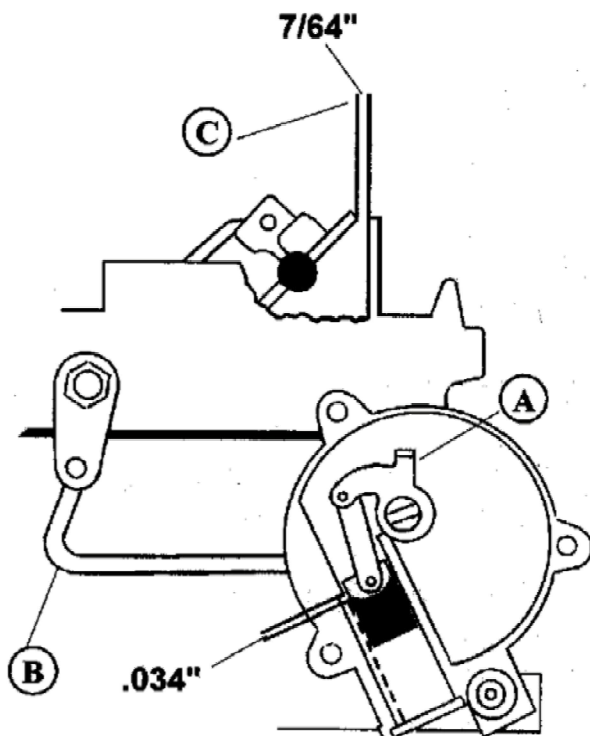

Open the choke valve and insert a $.034$ " wire (paper clip) (bend 90 degrees $1/8$ " from the end) between top of slot in the choke piston cylinder and the bottom of the slot in the piston. Hold the wire in position and close choke valve by pressing on the piston (A) until resistance is felt. The dimension (C) should be $7/64$ " between the top edge of the choke valve and the wall of the air horn. To adjust bend rod (B). Reassemble the thermostatic choke coil to the housing.

ADJUSTMENTS AND SPECIFICATIONS



Electric Choke Setting

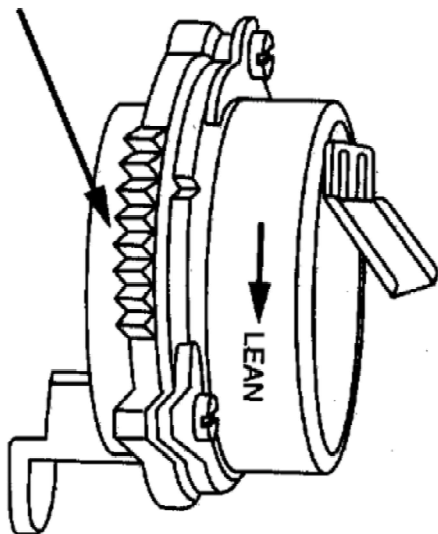

Rotate cover clockwise against spring tension until the mark on the thermostatic coil aligns with the index mark on the housing. Turn clockwise an additional two notches rich for the proper setting.

Fast Idle Linkage

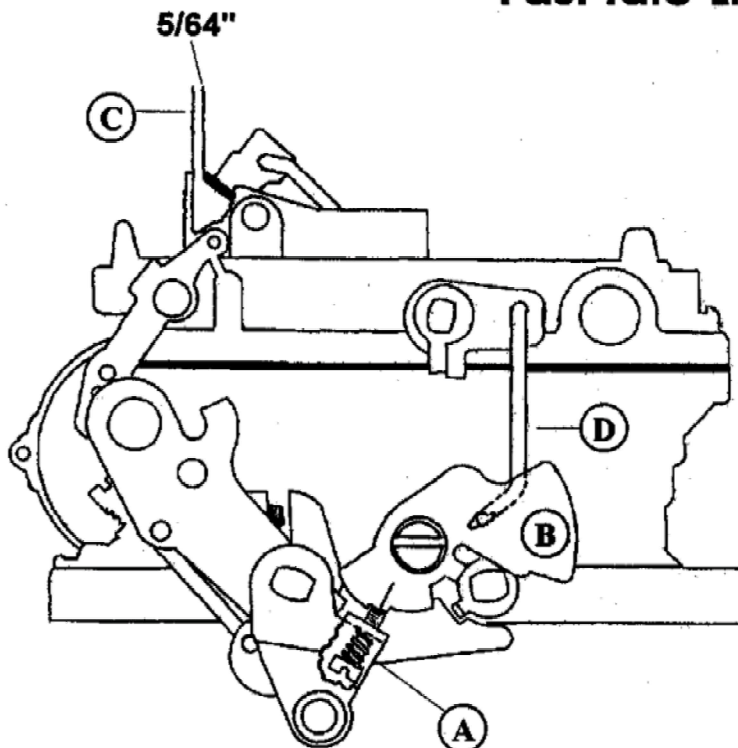

Place fast idle screw (A) on second step of cam (B). Move choke valve towards the closed position as far as possible without forcing. The dimension (C) should be $5/64$ " between the upper edge of the choke valve and the wall of the air horn. To adjust bend rod (D).

Secondary Throttle Lockout

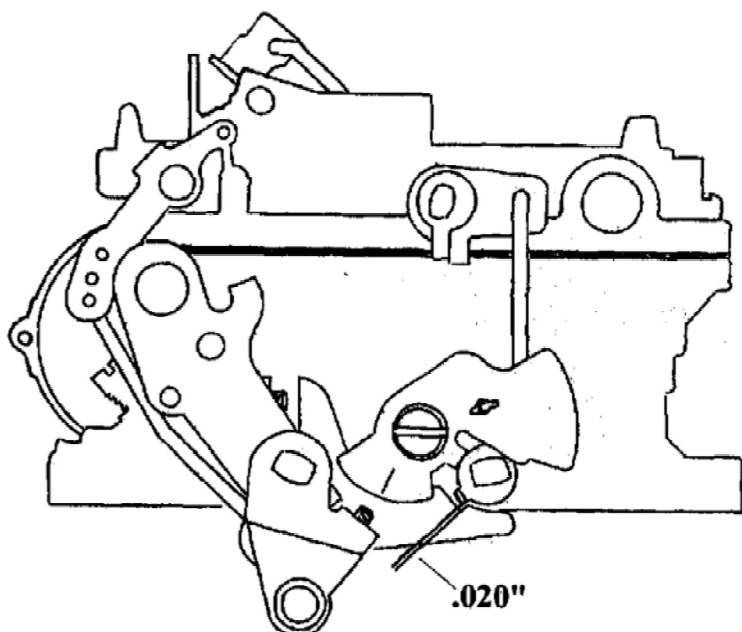

Crack the throttle valves and manually open and close the choke valve. The tang on the secondary throttle lever should freely engage in the notch of the lock out dog. To adjust, bend the tang on the secondary throttle lever.

Secondary Throttle Valve Opening

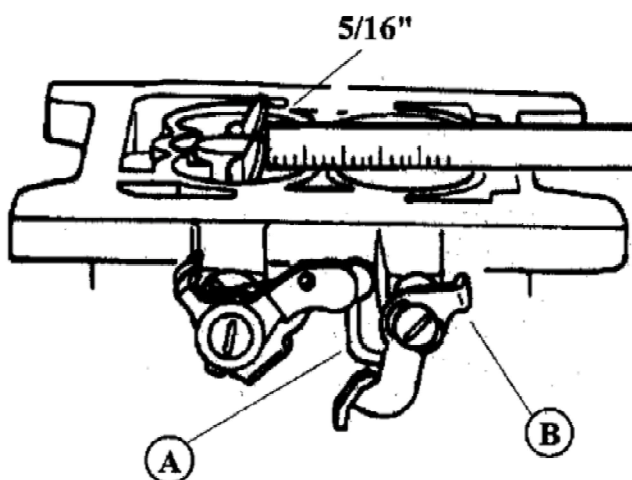

Secondary throttle valves should just start to open when there is $5/16$ " between the primary throttle valve and the bore of the carburetor as shown. To adjust bend rod (A). With the primary throttle valves wide open, adjust the stop tang (B) until the secondary valves are $27/32$ " from the edge of the bore before full vertical position.

ADJUSTMENTS AND SPECIFICATIONS



Secondary Throttle Valve Closing

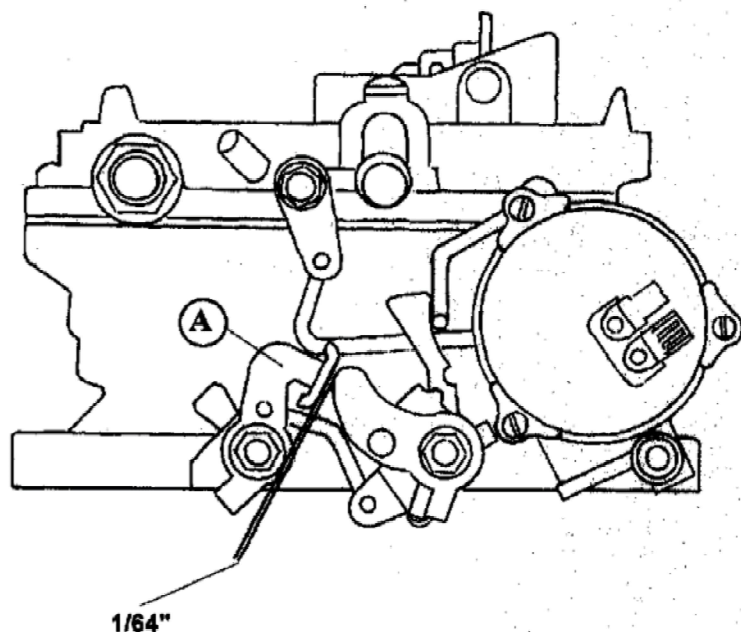

With the primary and secondary throttle valves tightly closed, there should be $1/64$ " clearance between the levers as shown. To adjust, bend the shoe on the lever (A).

Unloader

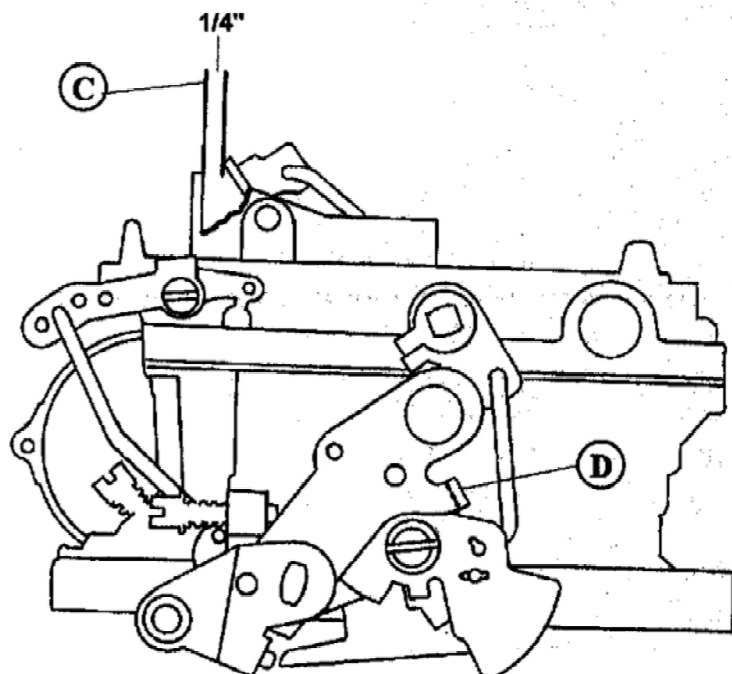

With the throttle valves open, close the choke valve as far as possible without forcing. The dimension (C) between the top edge of the choke valve and the inner wall of air horn should be $1/4$ ". To adjust, bend the tang (D) on the throttle lever.



ADJUSTMENTS AND SPECIFICATIONS

Bowl Vent

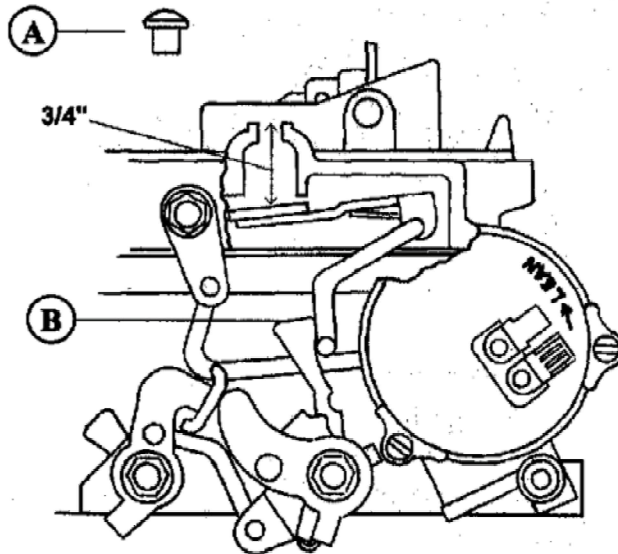

Remove the plug (A) from the hole in the air horn and insert a narrow ruler. Allow the ruler to rest lightly on the top of the valve. With the throttle valves closed and choke open, the dimension from the top of the valve to the top of the hole should be 3/4". To adjust, bend the operating lever (B).

Idle Mixture

The Carter AFB Competition Series carburetor has Idle Mixture Screws that provide a leaner Air/Fuel ratio when turned clockwise and richer Air/Fuel ratio when turned counter clockwise. The idle air flow is controlled by a screw that opens the Primary Throttles. The following procedure should be used to set the idle mixture and speeds.

1. Make sure the engine is warm engine choke is fully open.
2. Make sure the air cleaner is installed properly.
3. Set speed with the air screw as required.
4. Adjust the idle mixture screw on ONE side to get maximum RPM. Do not enrich beyond the maximum RPM point.
5. If the above changed the idle speed more than 50 RPM, then readjust the speed.
6. Adjust the other side of adjusted screw in Step 4 to get maximum RPM.
7. Recalibrate the speed.
8. Carefully trim each idle mixture screw to gain the maximum idle RPM.
9. Lean out enough to get a 25 RPM drop in RPM.
10. Reset speed to the desired RPM.
11. This is an idle set that is lean but best for the carburetor/engine performance. Setting the speed richer than as done above will not improve idle quality or performance, but may foul plugs.

INSTALLATION

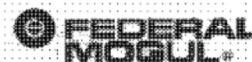

REMOVING THE OLD CARBURETOR

CAUTION: GASOLINE IS INVOLVED. WORK ONLY IN A WELL VENTILATED AREA, AWAY FROM SPARKS, OPEN FLAME OR ANY OTHER SOURCE OF IGNITION. GASOLINE VAPORS ARE HEAVIER THAN AIR, SO THEY COLLECT ON THE GROUND WHERE THE PILOT OF A FURNACE OR WATER HEATER COULD IGNITE THEM. ALWAYS HAVE A CLASS 'B' FIRE EXTINGUISHER NEARBY.

Disconnect the battery to prevent accidental shock or sparks.

Remove the air cleaner. Be careful not to damage the heated air duct or vacuum lines to the air cleaner during disassembly.

Disconnect the fuel line.

Disconnect all vacuum lines from the carburetor, noting their location and identify them for reassembly. Some lines may have to be traced through the engine compartment in order to determine their function. Refer to your vehicle's service manual as necessary. Disconnect the PCV hose and any power assist hoses.

Disconnect and remove all throttle linkage from the carburetor, keeping all parts for possible use during reassembly.

Disconnect and remove the choke heat tube or choke unit located on the intake manifold. Unbolt the carburetor and remove from the manifold. Remove the old carburetor flange gasket and clean the material from the manifold surface. Cover the manifold to prevent dirt or foreign material from falling into the engine.

INSTALLING THE AFB

NOTE: The Carter AFB is a square bore carburetor and will not operate properly if installed directly on a spread bore manifold. If the original equipment intake manifold will accept a Carter thermoquad or a Rochester Quadra-Jet a Carter P/N 9600A adapter will be required. The Carter AFB will bolt on to these intake manifolds but will not seal at the base gasket due to the different sealing pattern.

Place the carburetor on a bench or carburetor stand being careful not to damage the linkage or the throttle valves. Check for damage. Open the installation kit and lay out the assorted parts. Install the ball swivel studs using the lock washers on the throttle lever for your particular applications.

Install rubber caps on those tubes that will not be needed. Do not cap off the bowl vent or electric choke housing tube if your carburetor is so equipped.

Install new throttle and transmission linkage brackets. Install a new throttle cable if needed (2-Bbl to 4-Bbl conversion or dual-quad applications) (**CARTER #76-278**).

Place the new flange gasket (**CARTER #1P-303 [3 gaskets]**) on the manifold. Place the carburetor on the intake manifold and if required, install the throttle return spring bracket



INSTALLING THE AFB (Cont'd)

(CARTER #61P-500* [12"], #61P-501* [2 3/4"], or #180-370) (* includes angle bracket) and/or the idle solenoid bracket. Install and cross tighten the mounting nuts. **DO NOT** over tighten.

Connect the throttle linkage, transmission linkage, and throttle return spring. Operate the throttle and check to see that the throttle opens and closes smoothly. Correct any sticking or binding before proceeding any further. **DO NOT** lubricate throttle linkages.

Reconnect the vacuum hoses to their proper connection. Use the plastic tee provided to reroute the air cleaner hose to a manifold vacuum source. On those applications requiring vacuum for a power brake booster, install a vacuum fitting in place of the 1/4" pipe plug at the rear of the carburetor. Use good quality hose clamps to prevent loss of vacuum to the brake booster due to accidental disconnection during operation.

Re-connect the battery.

IMPORTANT: Before connecting the fuel line to the carburetor, flush the fuel line of any dirt or foreign material. Crank the engine with the coil wire removed from the distributor cap and grounded. Catch the fuel in a suitable container.

If metal fuel line has to be cut we suggest that a piece of quality rubber fuel line hose be used to connect the fuel line to the carburetor. **(CARTER #156-198 3/8" Fuel Line Adaptor)** Again, use a good quality gear type clamps to prevent leaks. Keep fuel line away from the exhaust manifold and other sources of high heat. Reconnect the fuel line. For low profile air cleaners, use a banjo design fuel line adapter **(CARTER #156-343)**.

Install a good quality fuel filter between the fuel pump and the carburetor:

CARTER #GF1 5/16" inlet & outlet; opaque plastic

CARTER #GF2 3/8" inlet & outlet; metal

Install air cleaner stud. Check for proper length and cut to size if desired. Install air cleaner gasket. **(CARTER #9600H Air Cleaner / CARTER #9600F Air Cleaner Filter)**

It may be necessary to use additional air cleaner gaskets for clearance or a 5/8" spacer **(CARTER #108-171)** with some original equipment air cleaners. Check the accelerator pump linkage and the choke linkage, as these are most likely to be affected by the air cleaner. Due to the various size and shapes of air cleaners, a different air cleaner may be required if modifications cannot be made to the original.

Recheck all throttle and choke linkages for smooth operation and check all hose connections.

Start engine and check for fuel leaks or vacuum leaks.

With the engine at operation temperature set idle speed and mixture to the manufacturer's specification.

Consult the manufacturer's procedure for adjusting the kickdown linkage for proper operation of the transmission.

The AFB carburetor at this time may require fuel metering adjustments. The **Carter #10-201 or 10-206 STRIP-KITS** and the **Carter #10-204 and #10-205 RODDING KIT** will provide you with a series of metering rods and jets that will enable you to adjust the carburetor to your specific engine needs. **Fine tuning the carburetor to the engine demands is the responsibility of the purchaser.**

MANUAL CHOKE CABLE

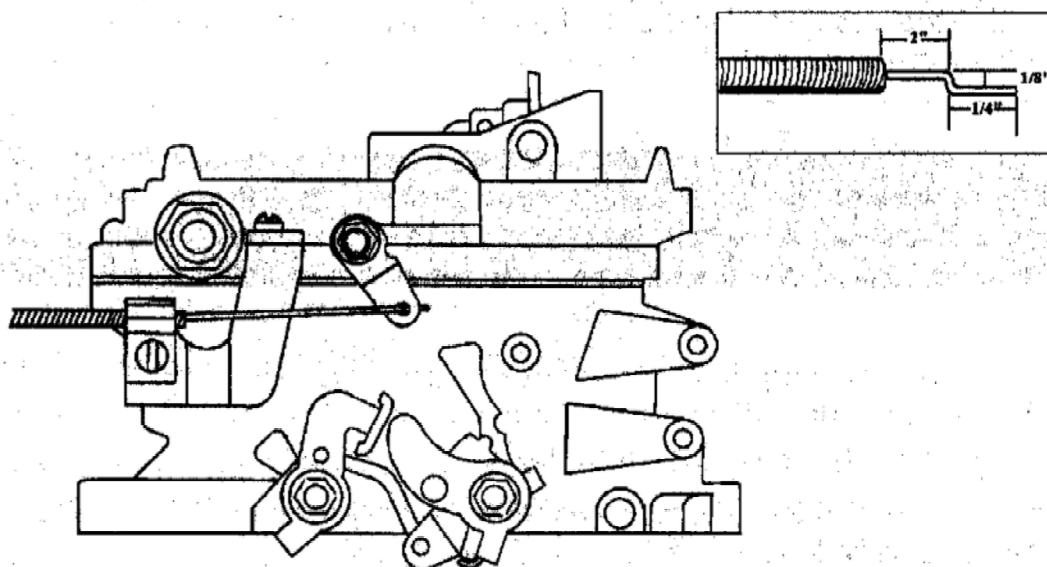

Mount knob assembly (**CARTER #9600C**) in a convenient location under the dash. Next install the cable through the firewall of the engine compartment. Trim the cable to the approximate length plus 6 inches.

Remove about 2 to 2 1/2" of outer casing so that the inner wire protrudes by this amount. Form a step in the inner choke wire as illustrated.

Insert choke wire in hole of choke lever and position cable in hold down bracket on the carburetor. Position end of the cable to provide full stroke of movement of wire and tighten clamp screw. Check to assure that the choke valve opens fully after the choke is closed.



ELECTRIC CHOKE INSTALLATION

Connect to the tube in the choke housing one end of the choke air hose and the other end to the fresh air tube located on the bowl cover near the air cleaner ring, on the choke side of the carburetor.

NOTE: This hose is necessary to use as a fresh air source for the choke. If not used the choke will be contaminated with dirt and foreign material, resulting in poor choke operation, and possible choke failure.

If you are installing an electric choke conversion kit (**CARTER #170P- 1314**) on a manual choke carburetor, the choke air hose is not necessary. Installed in the choke housing is a built-in filter to prevent contamination.

Inspect the choke coil cover to determine if the cover has two male terminals or one male and one female terminal.

1. If the choke coil cover has two male terminals select the ground wire with the female terminal end and install on either of the male terminals. Then remove one choke cover housing screw and install the eyelet end of the ground wire and reinstall the screw.
2. If the choke coil cover has a male terminal (marked positive [+]) and a female terminal (marked negative [-]) select the ground wire with the male terminal end. Install the male terminal end of the female (negative [-]) terminal of the choke coil cover. Then remove one choke coil cover housing screw and install the eyelet end of the ground wire and reinstall the screw.

Connect the red wire to the choke connection (positive [+]) terminal), and the other end to an ignition activated 12 volt source. **DO NOT ATTACH TO THE COIL.** A choke heat tube is not needed.

INSTALLATION INSTRUCTIONS



Chevrolet / General Motors

NOTE: Do Not Install The AFB On Computer Controlled (Feedback) Applications

Installation Kit contents:

- | | |
|----------------------------|----------------------------|
| 1 - Air Cleaner Stud | 1 - Air Cleaner Gasket |
| 1 - Flange Gasket | 1 - Large Rubber Cap |
| 1 - Small Rubber Cap | 1 - 36" Choke Wire (Red) |
| 1 - 6" Choke Wire (Male) | 1 - 6" Choke Wire (Female) |
| 1 - Choke Air Hose | 1 - 3/16" Plastic Tee |
| 2 - Ball Swivel Assemblies | |

You will need to purchase:

- 3/8" fuel line hose, filter and clamps
- Carburetor to manifold adapter (**CARTER #9600A**) for spread-bore manifolds
- EGR adapter (**CARTER #72-107**) to relocate the EGR on equipped models

2-Bbl to 4-Bbl Conversion

When converting from a two barrel to four barrel application a cleaner installation may be achieved by purchasing an inexpensive part from your local Chevrolet dealer. Throttle linkage bracket GM #352279 will clean up the installation. On some models the AC bracket may have to be modified slightly.

The third possible item is a new throttle cable. This may be necessary because Chevrolet uses (on some years) a shorter throttle cable for the two barrel applications. In some cases the two barrel cable will not extend far enough to provide smooth cable operation. We suggest you check your Chevrolet dealer for your specific application. A 17" stainless steel throttle cable, encased with a protective outer covering, is available (**CARTER #76-278**). This features 6" of adjustable travel with a disconnect fitting and locking brass bushing for easy removal.

If you are unable to find a four barrel transmission linkage bracket you may fabricate an extension link yourself. This can be achieved by using the template shown below. But use this only if you can not get the factory linkage.

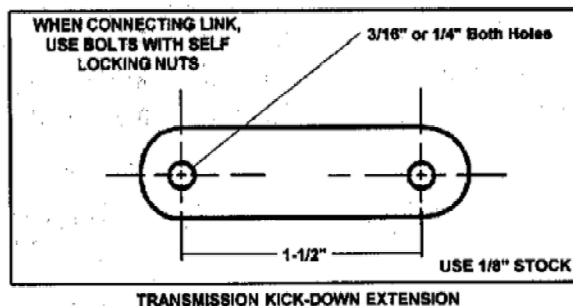



INSTALLATION INSTRUCTIONS

Chrysler Corporation

NOTE: Do Not Install The AFB On Computer Controlled (Feedback) Applications

Installation Kit contents:

- | | |
|--------------------------|----------------------------|
| 1 - Air Cleaner Stud | 1 - Air Cleaner Gasket |
| 1 - Flange Gasket | 1 - Large Rubber Cap |
| 1 - Small Rubber Cap | 1 - 36" Choke Wire (Red) |
| 1 - 6" Choke Wire (Male) | 1 - 6" Choke wire (Female) |
| 1 - Choke Air Hose | 1 - Large Plastic Tee |
| 1 - 3/16" Plastic Tee | |

You will need to purchase:

- * 3/8" fuel line hose, filter, and clamps
- * Carburetor to manifold adapter (**CARTER # 9600A**) for spread-bore manifolds

2-Bbl to 4-Bbl Conversion

When converting from a two barrel to a four barrel application you may find it helpful to purchase some inexpensive parts from your local Chrysler dealer. Purchasing these part may help you retain a clean installation and save you some down time.

The two barrel throttle bracket and kickdown linkage will not give proper alignment. These should be replaced with Chrysler four barrel throttle bracket and throttle control rod. Because of the different position of the throttle shaft, the throttle return springs should be replaced. In some cases the two barrel cable will not extend far enough to provide smooth cable operation. We suggest you check with your dealer for your specific application, or use our 17" stainless steel throttle cable (**CARTER # 76-278**).

Chrysler Cruise Control

When cruise control compatibility is essential, it is suggested you use a CARTER throttle lever adaptor (**CARTER # 3- 2087**). This adaptor should be used with AFB carburetors with either universal or GM throttle levers (9503, 9605, 9635, 9638, and 9755).

Purge Connection

On those models using a cannister purge, the purge hose should be connected to the PCV line closest to the carburetor by the large plastic "T".

INSTALLATION INSTRUCTIONS



Ford Motor Company

NOTE: Do Not Install The AFB On Computer Controlled (Feedback) Applications

Installation Kit Contents:

1 - Air Cleaner Stud	1 - Air Cleaner Gasket
1 - Flange Gasket	1 - Large Rubber Cap
1 - Small Rubber Cap	1 - 36" Choke Wire (Red)
1 - 6" Choke Wire (Male)	1 - 6" Choke Wire (Female)
1 - Choke Air Hose	1 - 3/16" Plastic Tee

You will need to purchase:

* 3/8" Fuel line hose, filter, and clamps.

On some EGR equipped models you will need to purchase:

- * Four 2 1/2" Long Manifold Studs
- * Carter EGR Diverter Tube - #145-845
- * EGR Valve Adaptor:
 - 1976 and later valve (3" bolt centers) - #8054
 - 1976 and later valve (3-1/4" bolt centers) - #8055

2-Bbl to 4-Bbl Conversion

When converting from a two barrel to four barrel application, an extension (**CARTER # 4-1288**) may be required to extend the automatic transmission kickdown lever.

Ford Throttle Lever Adaptor & Transmission Lever Extension

Some Ford applications require the automatic transmission kickdown lever to be located on the inside of the throttle lever. On these vehicles, CARTER recommends using our throttle lever adaptor (**CARTER # 3-2088**) on carburetors #9503, 9605, 9635, 9638, & 9755.



THROTTLE & CRUISE CONTROL CONNECTIONS

CARTER offers a variety of throttle ball studs and throttle/cruise control studs. The throttle ball and stud assortment (**CARTER # 108P-230**) features four of the most popular sizes. CARTER also provides a variety of seven different throttle and cruise control studs (**CARTER #108-223 to #108- 229**). See your CARTER dealer for your specific application requirement.

Dual Carburetor Applications

For those seeking to install dual quads, CARTER offers a linkage kit (**CARTER #115P-9001**) for use on hi-performance low rise street manifolds. This kit can be used as a progressive setup or direct to both carburetors. The contents include plated steel rods with universal spherical ends.

Dual Feed Fuel Bowl Cover

All production AFB carburetors contain a single fuel inlet on the passenger side of the carburetor. Carter Dual Feed Fuel Bowl Cover allows you to route the fuel line if necessary, to the driver side of the carburetor. Included is a gasket, inlet plug and gasket to block off the unused inlet. You can also use both inlets as a dual feed design (**CARTER No. 6P-2771**).

CARTER AFB TUNING SPECIFICATIONS



The AFB you have just purchased is a universal carburetor applicable to a variety of engine displacements. In addition, the engine may have been modified altering the characteristics of the engine's performance. For that reason, it may be necessary for your service technician or you to dial in or fine tune your AFB to your engine's or driving requirements.

Reviewed below and on the next page are the procedures for making adjustments to rods, jets, accelerator pump, needle/seat and float components. The following pages list base calibrations for your AFB as well as the dimensional increments for those parts. Finally, the last page illustrates a chart of the relationship between the metering rods and jets in your AFB and the adjustments that they make possible.

THE BASICS OF AFB METERING RODS AND JETS

All AFB carburetors have four metering jets (a set of primary and secondary jets are located at the back of the bowl and normally are not changed unless conditions require a richer mixture. This is determined by "reading" the spark plugs – a lighter color plug vs. a darker color plug denotes a lean running condition.

The primary jets, located at the front of each fuel bowl, control the fuel economy and 90% of part throttle driveability. Two-step metering rods are placed in the orifices of the primary jets to provide enrichment, just as a power valve does in other carburetors. During normal use, the large diameter of the rod is held in the jet; but when engine vacuum drops due to loading, the rod is lifted up and the smaller diameter of the rod allows for a richer mixture and more power.

Metering jets are supplied in **Carter's 10-201** or **10-206** Strip Kit at three-thousandths of an inch increments, so they offer a big change in the mixture. The jets numbering system is keyed to its size. All jet numbers start with 120- and the last three numbers indicate the orifice size. Therefore, 120-389 means that the jet orifice is .089; whereas, 120-401 means that the orifice is .101 of an inch.

Since the metering rod diameter reduces the effective area of the jet, the *primary* jets are *always larger* than the secondary jets which have no metering rods in them.

If normal driveability is acceptable; but fuel economy is only slightly low, it is best to change the metering rods. This can be done without

removing the top of the carburetor. Simply remove the air cleaner and two metal covers can be seen on each side of the carburetor. Loosen the single screw holding each cover and rotate the covers so that the piston can pop out of the cylinder. Remove the piston, with metering rod attached, and depress the wire clip that secures the metering rod in the piston. Replace the rod with a larger or smaller diameter rod as needed. When reinstalling, push down on the piston and wiggle the rods around until they fall into the jet orifices. Hold the piston down and rotate the cover back over the piston and secure the screw. This should take about five minutes per side. Then test drive the vehicle to assure good operation and check fuel economy again. This can be repeated until all rods have been tried.

Don't concern yourself with the smaller diameter of the rod since this only affects the enrichment mixture which is staged by the strength of the springs below the pistons and the vacuum of the engine. If you experience flatness or lack of power on light accelerations at higher speeds you may want to install a heavier spring below the pistons so the enrichment will come in sooner. Always use the lightest spring that gives acceptable driveability since early step-up consumes fuel. An assortment of springs are available (**Carter # 61P-1083** [three strengths] or **Carter # 61P-1085** [five strengths]).

If acceptable results are not attained with the rod sizes available, the primary jets will have to be changed to a larger or smaller orifice. To make jet changes, you must remove the fuel bowl cover and any linkage. To remove the jet, simply loosen the jet with a screw driver, then use a sharpened wood pencil to be pressed in the jet orifice to complete the removal. To install the jet, just reverse the procedure. In order to get back to the approximate area, it is easiest to subtract the rod diameter from the jet diameter for the last combination, then subtract the above value from the new jet diameter to arrive at a new rod diameter. As an example, say you have a .098 jet with a .076 rod and you are still too rich -- subtract .076 from .098 and get .022. You want to go leaner so select a .092 jet (two sizes leaner) and subtract the .022 from .092 giving a .070 diameter rod. This is only an approximate size since the correct method would be to subtract areas which yield a .068 rod diameter. You have both of these sizes in the **Carter 10-201** or **Carter 10-206** Strip Kit, so you can cover these combinations and still go leaner.



CARTER AFB TUNING SPECIFICATIONS (Cont'd)

HIGH ALTITUDE

Altitude has a direct effect on the operation of any carburetor. The higher up you go, the thinner the air becomes and the richer the carburetor runs.

Since all Carter carburetors are calibrated at almost sea level, here is a "rule of thumb." Anytime you're above 4,000 feet, you need to lean the carburetor one thousandth for every 1,000 feet of altitude you go up. An example, if you're driving at 7,000 feet, you will need to reduce the primary jet size three thousandths.

SUPERCHARGERS AND TURBOCHARGERS

The popularity of Turbochargers and Superchargers has increased over the last few years and a lot of these installations are being made with Carter Carburetors. Here are some suggestions for dialing the carburetor to the system.

First of all, consult the manufacturer for his recommendations. They have developed the equipment and if you give them the carburetor part number, they probably can tell you what metering parts you will need.

Second, order one **Carter 10-206** Strip Kit for each carburetor in use. The **10-206** contains metering rods and jets with the extra enrichment needed for supercharged applications.

Third, the carburetor is going to be lean for either a "Turbo" or "Blower" installation without a metering change, so you could have engine damage and it won't be the fault of the carburetor. A good starting calibration is to use one step richer jet in both the primary and secondary.

ACCELERATOR PUMP ADJUSTMENTS

The AFB acceleration pump provides an immediate shot of fuel, when the throttle is opened, in order to prevent hesitations and/or sags on drive-away. You may need to increase or decrease the quantity of fuel delivered or simply change the rate at which the fuel is delivered. Trial and error will yield the best results.

The quantity of fuel can be varied by changing the pump stroke. The longer stroke delivers the most fuel.

The stroke is changed by bending the wire link or pump rod. Normal stroke is $13/32"$ (.406) with the idle stop screw backed out. The rate of

the pump can be changed by moving the pump rod to different holes in the pump lever. There are three holes provided in the lever. Normal position for the rod in the center hole with the stroke adjusted to $13/32"$. For a faster pump, use the hole nearer the pivot. This gives a $15/32"$ stroke if the pump rod is not readjusted. The hole farthest from the pilot gives a slower pump action, and the stroke will change to $11/32"$ if the pump is not adjusted. Maximum stroke for pump is $1/2"$. Ideally, the stroke should be adjusted back to the $13/32"$ stroke regardless of the hole used on the lever arm.

Depending upon your needs, changing the pump cluster enables you to initially richen your engine. This lessens momentary hesitation on acceleration. **Carter # 48P379** contains three (3) different nozzles to make this adjustment.

Too little pump shot will give a bog or hesitation on brisk acceleration from a stop. Too much pump will produce weak acceleration and possible black smoke out the exhaust. Have someone follow behind you to look for the black smoke since it could be hazardous to be observing the rear when you are accelerating forward.

SECONDARY VELOCITY VALVES

The air flow sensing secondary valve acts like throttle valves below the secondary venturis. When air flow is low, no secondary flow takes place until the counterweight is overcome even though the secondary throttle valves are wide open.

A secondary transitional sag or bog can be overcome by delaying or advancing the opening of the secondary velocity valves. This can be accomplished by drilling holes in the weights to lighten them, or if more weight is needed the holes can be filled with lead split shot fishing weights. (The holes should be chamfered with a larger drill in order to form a lead "rive" that will not fall out.

Holes of a $3/16"$ diameter farthest from the pivot shaft are usually sufficient.

If you make a mistake, replacement secondary velocity valves are available (**Part No. 3-2079**).

SECONDARY BOGGING

Another method of curing a secondary bog is to increase the "early feed" fuel supply coming from the tubes located at the edge of the velocity valve.

CARTER AFB TUNING SPECIFICATIONS (Cont'd)



The secondary cluster assemblies must be modified by removing a small tube from the bottom of the cluster. Do not tamper with the large tube.

Remove small tube by clamping whole tube in a vise (tube is horizontal and should be flattened using a wood dowel or a piece of 1" x 2" wood), tap on gasket surface of cluster until tube comes out. Do not allow cluster to twist, as tube may be broken and then will be impossible to remove without drilling. Repeat for mating cluster and reinstall in carburetor, road test car and reset secondary if necessary.

FUEL INLET NEEDLE/SEAT ASSEMBLIES AND FLOAT SETTINGS

The **10-201** or **10-206 Strip Kit** contain two pair of inlet needle/seat assemblies which are larger than those supplied with your AFB. The .111 orifice assembly can be used for normal use, but the .120 orifice assembly should be used only when performance conditions demand more fuel (leaning out at higher speeds.)

There are two ways to get more fuel into a carburetor. One is by using a larger orifice inlet assembly, the other is by increasing the fuel pressure. Both these methods place an additional burden on the floats and should be used only for performance applications.

The AFB comes equipped with a .101 inlet assembly which requires a 3/8" clearance between the cover gasket and the float. The .111" inlet assembly would need 13/32" clearance; whereas, the .120 inlet assembly needs 14/32" clearance between the gasket and the float. This dimension is known as the float setting. All of these dimensions are for 5 PSI of fuel pressure.

If your fuel pressure is higher, the clearance would have to be increased. When changing the float setting, use a needle-nose plier to bend the float arm near the pivot pin. There is a flat area for this purpose. Do not push or pull on the float body.

"COMPETITION SERIES" AFB'S AND ALL OTHER AFB CARBURETORS Maximum Flow vs. Needle Seats Orifice

If you use your car or boat under hard driving conditions, you may want to consider the **CARTER 26P-965S** needle/seat assembly. These have spring-loaded needles to absorb the shock and prevent the carburetor from flooding during rough operation. The float setting for these inlet assemblies is 5/16" clearance between the bowl gasket and the float body. A spring loaded needle/seat will be used in all future AFB carbs, except marine models.

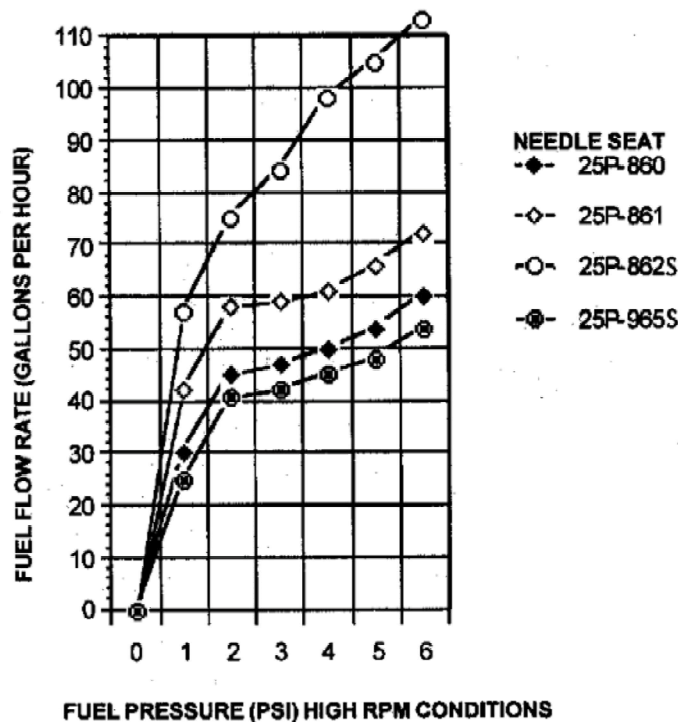



BASE CALIBRATIONS

	METERING RODS			KIT CONTENTS			
	PART NUMBER*	CRUISE STEP	POWER STEP	STRIP KIT 10-201	ROD KIT 10-204	ROD KIT 10-205	ROD KIT 10-206
LEAN ↓ RICH	16P-7658	.0760	.0580				
	16P-691	.0760	.0580	2 Each			
	16P-7652	.0760	.0520				
	16P-7646	.0760	.0460				2 Each
	16P-7452	.0740	.0520				
	16P-7446	.0740	.0460				2 Each
	16P-7440	.0740	.0400				
	16P-388	.0730	.0600	2 Each			
	16P-7347	.0730	.0470				
	16P-7252	.0720	.0520		2 Each		
	16P-7246	.0720	.0460		2 Each		2 Each
	16P-7240	.0720	.0400		2 Each		
	16P-544	.0715	.0580	2 Each			
	16P-241	.0705	.0475	2 Each			
	16P-7060	.0700	.0600				
	16P-7052	.0700	.0520		2 Each		
	16P-7047	.0700	.0470				2 Each
	16P-7046	.0700	.0460		2 Each		
	16P-7040	.0700	.0400		2 Each		
	16P-98	.0680	.0555	2 Each			
	16P-6852	.0680	.0520			2 Each	
	16P-6846	.0680	.0460			2 Each	2 Each
	16P-6840	.0680	.0400			2 Each	
	16P-6652	.0660	.0520			2 Each	
	16P-6646	.0660	.0460			2 Each	2 Each
	16P-6640	.0660	.0400			2 Each	
	16P-485	.0650	.0520	2 Each			

Metering Rods are listed in "Lean to Rich" order with the leanest at the top of the chart, the chart is sorted first by "cruise" mixture, and then by the "power" mixture. Changing to a rod with the same cruise diameter and smaller power diameter will richen the wide open throttle mixture without impacting part throttle driveability.

- Sold in Pairs Only

	METERING JETS		
	PART NUMBER	ORIFICE DIAMETER	STRIP KIT P/N
LEAN ↓ RICH	120P-371	.071	10-201
	120P-374	.074	10-201
	120P-377	.077	10-201
	120P-380	.080	10-201
	120P-383	.083	10-201
	120P-386	.086	10-201/10-206
	120P-389	.089	10-201
	120P-392	.092	10-201/10-206
	120P-395	.095	10-201/10-206
	120P-398	.098	10-201/10-206
	120P-400	.100	10-206
	120P-401	.101	10-201/10-206
	120P-404	.104	10-201/10-206
	120P-407	.107	10-201/10-206
	120P-410	.110	10-201/10-206
	120P-413	.113	10-206
	120P-416	.116	10-206
	120P-419	.119	10-206

METERING JETS			
SPRING ID COLOR	VACUUM RATING	SPRING KIT 61P-1083	SPRING KIT 61P-1085
Natural/Green	3"		2 Each
Yellow	4"	2 Each	2 Each
Red/Orange	5"	2 Each	2 Each
Pink	7"	2 Each	2 Each
Black	10"		2 Each

Metering Rod Springs determine the point at which the rod changes from the "cruise" to the "power" position. Each metering rod will have a spring, and they should be changed in pairs.

*Unless otherwise indicated, parts in this catalog are not intended for use in emission controlled vehicles that must comply with federal, state and/or local emission regulations. Replacement for certified emission O.E. combinations are referenced in the TRW, Sealed Power or Carter standard replacement parts catalogs.

AFB CARBURETOR CALIBRATION CHART



THE ROD & JET DIMENSIONS SHOWN REFLECT THOSE OF THE RODS & JETS IN THE 10-201 STRIP KIT OR ITS INDIVIDUAL REPLACEMENT PARTS

Economy Position / Low Speed

Metering Rod Step Dimensions

METERING JET ORIFICE DIMENSIONS	.076	.073	.0725	.0715	.0705	.070	.0695	.068	.065
	.071				.0005	.001	.0015	.003	.006
	.074	.001	.0015	.0025	.0035	.004	.0045	.006	.009
	.077	.004	.007	.0075	.0085	.0095	.010	.0105	.015
	.080	.004	.007	.0075	.0085	.0095	.010	.0105	.015
	.083	.007	.010	.0105	.0115	.0125	.013	.0135	.018
	.086	.010	.013	.0135	.0145	.0155	.016	.0165	.021
	.089	.013	.016	.0165	.0175	.0185	.019	.0195	.024
	.092	.016	.019	.0195	.0205	.0215	.022	.0225	.024
	.095	.019	.022	.0225	.0235	.0245	.025	.0255	.027
	.098	.022	.025	.0255	.0265	.0275	.028	.0285	.030
.100	.024	.027	.0275	.0285	.0295	.030	.0305	.032	
.101	.025	.028	.0285	.0295	.0305	.031	.0315	.033	
.104	.028	.031	.0315	.0325	.0335	.034	.0345	.036	
.107	.031	.034	.0345	.0355	.0365	.037	.0375	.039	
.110	.034	.037	.0375	.0385	.0395	.040	.0405	.042	

RICHER →

Lean Step

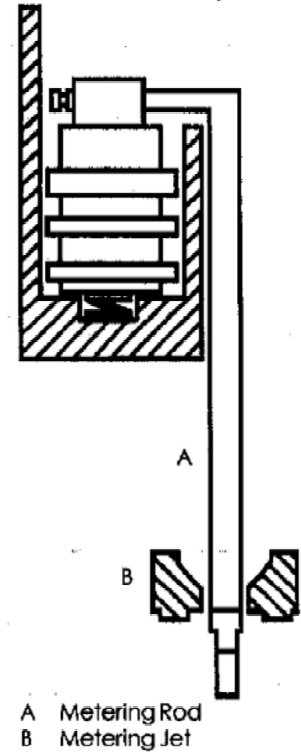

Power Position / High Speed

Metering Rod Step Dimensions

METERING JET ORIFICE DIMENSIONS	.060	.058	.0555	.055	.052	.0475	.047	
	.071	.011	.013	.0155	.016	.019	.0235	.024
	.074	.014	.016	.0185	.019	.022	.0265	.027
	.077	.017	.019	.0215	.022	.025	.0295	.030
	.080	.020	.022	.0245	.025	.028	.0325	.033
	.083	.023	.025	.0275	.028	.031	.0355	.036
	.086	.026	.028	.0305	.031	.034	.0385	.039
	.089	.029	.031	.0335	.034	.037	.0415	.042
	.092	.032	.034	.0365	.037	.040	.0445	.045
	.095	.035	.037	.0395	.040	.043	.0475	.048
	.098	.038	.040	.0425	.043	.046	.0505	.051
.100	.040	.042	.0445	.045	.048	.0525	.053	
.101	.041	.043	.0455	.046	.049	.0535	.054	
.104	.044	.046	.0485	.049	.052	.0565	.057	
.107	.047	.049	.0515	.052	.055	.0595	.060	
.110	.050	.052	.0545	.055	.058	.0625	.063	

RICHER →

Rich Step

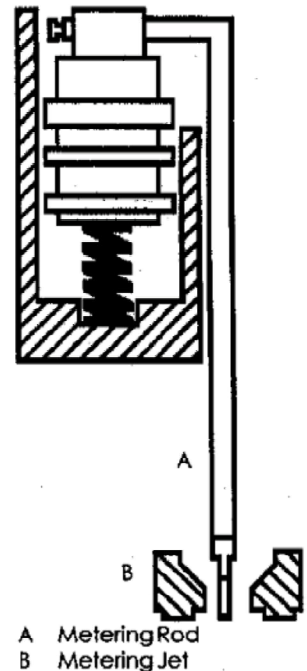



CARTER AFB CALIBRATION LOG

	DATE	METERING ROD	PRIMARY METERING JET	SET-UP SPRING	SECONDARY METERING JET	COMMENTS
						BASE CALIBRATION
1						
2						
3						
4						
5						
6						
7						
8						
9						
10						
11						
12						
13						
14						
15						
16						
17						
18						
19						
20						

CARBURETOR TROUBLE-SHOOTING INFORMATION



1. Always install or replace a good in-line gas filter to protect your carburetor from foreign material and dirt before installing and starting the engine. Check for fuel leaks.
2. Vacuum leaks are about the most common problem. Make sure all vacuum lines and hoses are connected properly to the carburetor and manifold. If an adaptor is used, make sure gaskets are used above and below the adaptor and seal properly.

Possible Solution	Situation											
	Carburetor floods	Carburetor won't idle	Will not adjust properly	Loads-up, stumbles on acceleration	Surges, cuts out	Vacuum leak	Backfires	Fuel leaks at shafts	Rough idle	Boggs	No power	Hard starting
Check for foreign material inside carburetor needles and seats — Replace needles and seats.	X							X				X
Check for air leak at base of carb., manifold, adaptors, etc. Make sure base gasket seals properly and all outlets are plugged or connected.		X	X		X	X	X		X	X	X	
Check float level and drop. Reset to specifications if needed.	X			X				X				X
Check float for leak. Replace if gas found inside of float.	X							X				
Excessively rich, requires leaner rods and/or jets. Check primary side. If performance cam is used, change metering rod springs.				X						X		
Too lean, requires richer rods and/or jets. Check secondary side for hanging throttle valves.					X		X			X	X	
Check ignition, timing, points, cap or vacuum leak at base of carburetor.		X	X		X	X	X		X			X
Off road vehicles need spring-loaded needles and seats. See 25P965S.	X							X				
Check air horn or top gasket for breaks and/or crimps.	X											
Increase accelerator pump stroke. Larger or smaller pump squiters may be needed.				X							X	
Check choke setting. May require richer or leaner setting.		X		X	X		X		X			X
Check idle mixture screws adjustment. See service instructions.		X	X						X			
Engine temperature too hot causing fuel to boil and run over. Use heat shield between carb. and intake manifold.								X				X
Replace carburetor filter.	X			X							X	X
Dirt may be blocking the low speed circuit. Apply air pressure after cleaning unit and install inline gas filter.		X	X		X				X			
Check engine compression for good balance.					X		X		X		X	