

# EL CAMINO

## EL CAMINO MODEL SELECTOR

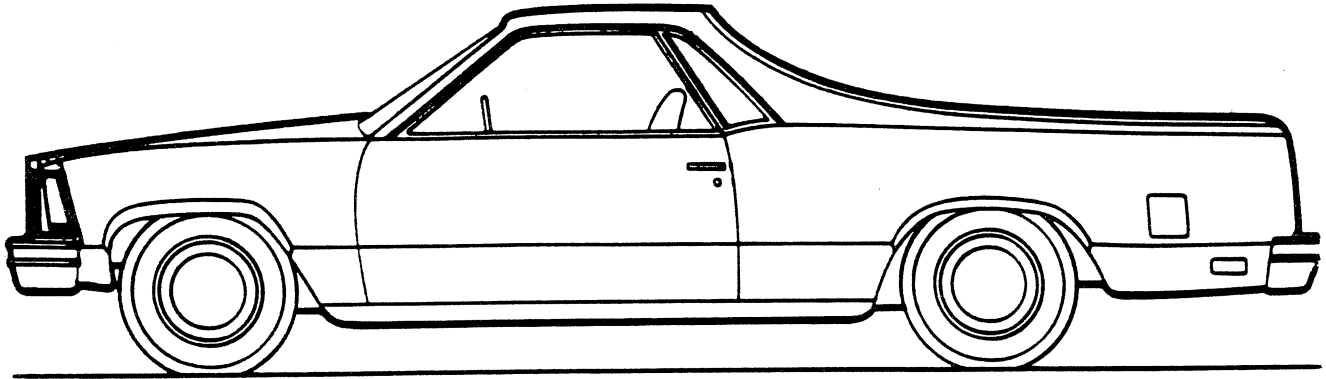

MODEL NUMBER	
<b>CLASSIC</b>	<b>SUPER SPORT</b>
1AW80	1AW80 & Z15

# EL CAMINO

## STANDARD SPECIFICATIONS

(See Blue Tab Section for Specification Details)

<b>Engine</b> <b>Base Equip.</b> ..... <b>Clutch</b> ..... <b>Air Filter</b> ..... <b>Oil Filter</b> ..... <b>Exhaust System</b> ..... <b>Emission Control Systems</b> .....	3.3 Litre, 200 2-bbl. V6▲ 9.1"; 72 sq. in. Oiled-paper Element Throwaway Type; 1-qt. Single; Aluminized Meet Government Requirements
<b>Suspension, Front</b> ..... <b>Capacity</b> ..... <b>Springs @ Ground—Range*</b> ..... <b>Shock Absorbers</b> .....	Independent; Coil Springs 2920 lb. 808/1167 lb. ea. 1" dia.
<b>Suspension, Rear</b> ..... <b>Axle Capacity</b> ..... <b>Axle Ratio</b> ..... <b>Springs @ Ground—Range*</b> ..... <b>Shock Absorbers</b> .....	Hypoid; Coil Springs 2750 lb. 2.73 1061. 1213 lb. ea. 1" dia.; Air Booster Type
<b>Brakes</b> ..... <b>Front</b> ..... <b>Rear</b> ..... <b>Parking</b> .....	Hydraulic; Self-adjusting; power assisted Disc; 10.5" Rotor Drum; 9.5" x 2" Cable to Rear Wheels
<b>Electrical</b> ..... <b>Battery—Freedom Type</b> ..... <b>Delcotron Generator</b> .....	12 Volt; Negative Ground 2500 watts @ 0°F. 37 amp.
<b>Frame</b> .....	Carbon Steel; Perimeter Type
<b>Fuel Tank (nominal capacity)</b> .....	17.5 gal.
<b>Steering Gear Type</b> ..... <b>Linkage</b> .....	Manual; Recirculating Ball Parallelogram
<b>Transmission</b> ..... <b>Shift Location</b> .....	Fully Synchronized 3-Speed Floor
<b>Tires</b> .....	(5) P205 75R-14
<b>Wheels</b> .....	(5) Disc; 14" x 6"

▲Standard engine not available for registration in the State of California; see Power Teams chart.

\*The capacity of front and rear springs actually installed is dependent on the computed weight of the vehicle with optional equipment as ordered.

# EL CAMINO

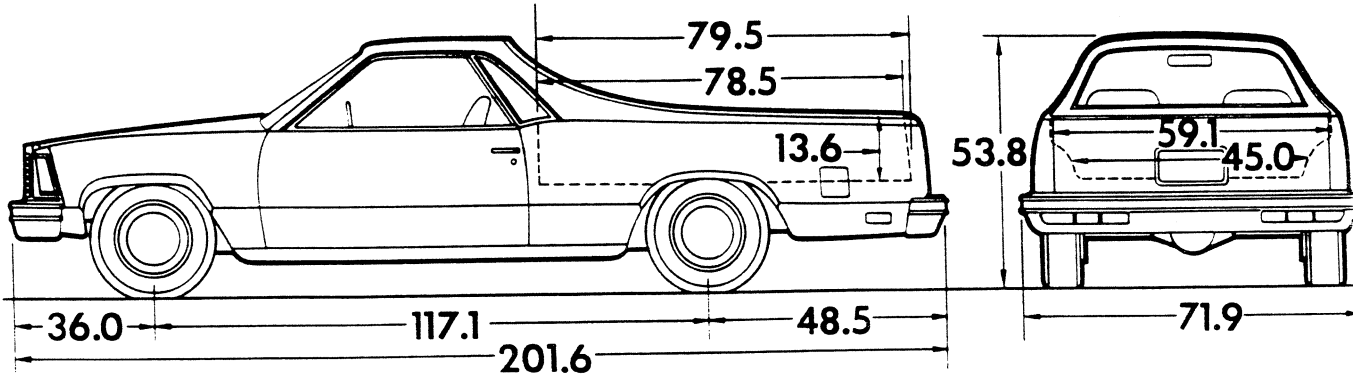

Model	Engine No. Cyl.	Curb Weight (lb)			Model Weight (lb)*			Ground Clearance (in.)	
		Front	Rear	Total	Front	Rear	Total	Front	Rear
1AW80	6	1792	1382	3174	1975	1649	3624	7.2	8.7
1AW80 With Z15	6	1792	1382	3174	1975	1649	3624		

★ Dimensions with standard equipment, unloaded.

\* Model Weight includes Curb Weight plus occupants (standard seating capacity x 150 lb). Total Model Weight may vary as much as ±150 lbs to allow for production build variation.

## GVWR SELECTOR

Engine	GVW Range (lb)	▲GAWR(lb)		Minimum Equipment Required for GVW Range		
		Front	Rear	Tires, Front	Tires, Rear	Chassis Equipme:
6	4424 to 4674	1930 to 2108	2490 to 2566	P205/75R-14B	P205/75R-14B	Standar

▲ GAWR—Gross Axle Weight Rating.

# EL CAMINO

## POWER TEAMS

ENGINE	TRANSMISSION	REAR AXLE	
		Capacity (lb)	Ratio and Code

### ALL STATES EXCEPT CALIFORNIA

		2.41	2.73	2.73 G92*
3.3 Litre 200 2-bbl V6-L26 (Standard Engine)	3-Speed Manual (Std)—MM3	—	X (Std)	—
	Automatic—MX1	—	X (Std)	—
305 2-bbl V8-LG3	4-Speed Manual—MM4	—	X (Std)	—
	Automatic—MX1	X (Std)	—	X
350 4-bbl V8-LM1	4-Speed Manual—MM4	—	X (Std)	—
	Automatic—MX1	X (Std)	—	X

- ◆ Locking Differential rear axle available for all axle ratios.  
\* Performance Ratio.

### CALIFORNIA ONLY

		2.41	2.73	2.73 G92*
▲ 231 2-bbl V6-LD5	Automatic—MX1	—	X (Std)	—
▲ 305 2-bbl V8-LG3	Automatic—MX1	X (Std)	—	X
▲ 350 4-bbl V8-LM1	Automatic—MX1	X (Std)	—	X

- ▲ Optional V6 or V8 engine must be ordered in California.  
◆ Locking Differential rear axle available for all axle ratios.  
\* Performance Ratio.

## ENGINE RATINGS

### ALL STATES EXCEPT CALIFORNIA

SAE Net Ratings @ 85°F	3.3 Litre 200 2-bbl V6	305 2-bbl V8	350 4-bbl V8
Net Horsepower . . . . .	95 @ 3800 rpm	145 @ 3800 rpm	170 @ 3800 rpm
Net Torque, lb-ft. . . . .	160 @ 2000 rpm	245 @ 2400 rpm	270 @ 2400 rpm

### CALIFORNIA ONLY

SAE Net Ratings @ 85°F	231 2-bbl V6	305 2-bbl V8	350 4-bbl V8
Net Horsepower . . . . .	105 @ 3400 rpm	135 @ 3800 rpm	160 @ 3800 rpm
Net Torque, lb-ft. . . . .	185 @ 2000 rpm	240 @ 2000 rpm	260 @ 2400 rpm

# EL CAMINO

## 1978 VEHICLES WITH STANDARD EQUIPMENT

Prices shown are effective with vehicles produced on or after February 6, 1978

Description	Model Number	Wheel-base	Factory D&H <sup>§</sup>	List Price	Mfr's Suggested Retail Price <sup>★</sup>	Destination Charge & Group Number	Total
<b>◆ 3.3 Litre (200 Cu. In.) V6 Engine—Engine Ordering Code L26</b>							
El Camino—							
3-Passenger .....	1AW80	117.1"	13.10	4640.00	4653.10	12.....	.....
Super Sport—							
3-Passenger .....	1AW80/Z15	117.1"	13.10	4819.00	4832.10	12.....	.....

- ★ Manufacturer's Suggested Retail Prices do not include applicable destination charges, state and local taxes, license fees, options or accessories.  
 ◆ Refer to Power Team Chart for California Emission Certification Requirements.

## OPTIONS AND ACCESSORIES WHEN INSTALLED BY CHEVROLET

Prices shown are effective with vehicles produced on or after February 6, 1978

Description	Added Weight (F) (R)		Option Number	Factory D&H <sup>§</sup>	List Price	Mfr's Suggested Retail Price <sup>◇</sup>
<b>POWER TEAMS</b>						
<i>(See Power Teams Chart for availability and specifications)</i>						
<b>Engines:</b>						
231 Cu. In. V6. Available only when YF5 California Emission and MX1 Automatic Transmission are specified.....	8	-5	LD5	N.A.	40.00	40.00
305 Cu. In. V8. Available only when N41 Power Steering is specified. YF5 California Emission available only when N41 Power Steering and MX1 Automatic Transmission are specified. Not available when MM3 3-Speed Manual Transmission or NA6 High Altitude Emission are specified.....	158	22	LG3	N.A.	190.00	190.00
350 Cu. In. V8. Available only when N41 Power Steering is specified. YF5 California Emission and NA6 High Altitude Emission available only when N41 Power Steering and MX1 Automatic Transmission are specified. Not available when MM3 3-Speed Manual Transmission is specified.....	194	18	LM1	N.A.	305.00	305.00
<b>Transmission:</b>						
4-Speed Manual.....	2	0	MM4	N.A.	125.00	125.00
<i>Automatic</i>						
With LD5 Engine.....	-4	-2	MX1	N.A.	307.00	307.00
With L26 Engine.....	-1	4	MX1	N.A.	307.00	307.00
With V8 Engine.....	36	12	MX1	N.A.	307.00	307.00
<b>Axles, Rear:</b> <i>(See Power Team Chart for availability)</i>						
Performance Ratio.....	0	0	G92	N.A.	15.00	15.00
Positraction.....	0	0	G80	N.A.	59.00	59.00

## POWER ASSISTS

<b>Door Lock System, Power:</b> Electric.....	1	0	AU3	N.A.	80.00	80.00
<b>Seat, Power:</b> <i>Six Way.</i> Driver's side only with 50/50 seat. Not available when bucket seats are specified.....	10	8	A42	N.A.	151.00	151.00
<b>Steering, Power</b> .....	20	0	N41	N.A.	152.00	152.00
<b>Windows, Power:</b> Electric.....	5	3	A31	N.A.	124.00	124.00

- § D&H amounts reflect provision for pass through of tire weight tax imposed on manufacturer or importer of tires.  
 ◇ State and local taxes not included.

# EL CAMINO

## OPTIONS AND ACCESSORIES WHEN INSTALLED BY CHEVROLET

Prices shown are effective with vehicles produced on or after February 6, 1978

Description	Added Weight (F) (R)	Option Number	Factory D&H <sup>§</sup>	List Price	Mfr's Suggested Retail Price ◊
<b>OTHER OPTIONS</b>					
<b>Air Conditioning: Four-Season.</b> Includes K76 61-amp Generator and increased cooling. L26 3.3 Litre (200 Cu. In.) and LD5 231 Cu. In. available only when N41 Power Steering is specified.					
Without L26 3.3 Litre (200 Cu. In.) Engine	51 4	C60	N.A.	544.00	544.00
With L26 3.3 Litre (200 Cu. In.) Engine	63 5	C60	N.A.	544.00	544.00
<b>Battery: Heavy-Duty.</b> 4000 Watt.	7 -1	UA1	N.A.	18.00	18.00
<b>Belts, Deluxe: Color-Keyed Seat and Shoulder.</b> Includes brushed metal buckles (Standard belts and plastic buckles are black.)					
<i>REPLACING STANDARD NUMBER OF BELTS:</i>					
With bench seat—3 seat and 2 shoulder	0 0	AK1	N.A.	16.00	16.00
With bucket seats—2 seat and 2 shoulder	0 0	AK1	N.A.	15.00	15.00
<b>Black Knight:</b> Available only when 19 paint is specified. Not available when D91 Conquista, BW2 or BX8 Moldings, PB2 or N95 Wheel Covers are specified.					
	0 0	Z16	N.A.	64.00	64.00
<b>Bumper Equipment:</b>					
<i>Bumper Rub Strips.</i> Front and Rear. Includes black resilient impact strips.					
	2 2	VE5	N.A.	36.00	36.00
<i>Guards, Bumper.</i> Front and Rear.					
	2 2	V30	N.A.	40.00	40.00
<b>Clock, Electric.</b> Included when UF7 Gage Package or U14 Instrumentation is specified					
	0 0	U35	N.A.	21.00	21.00
<b>Conquista:</b> Not available when Z15 Super Sport is specified. Includes BX8 front fender, body side and tailgate moldings. See Conquista Interior and Exterior Color Selection Chart for interior and exterior color availability and ordering information					
	0 0	D91	N.A.	146.00	146.00
<b>Console:</b> Available only when bucket seats are specified. Shift lever is mounted on console					
Without MX1 Transmission	5 1	D55	N.A.	80.00	80.00
With MX1 Transmission	10 5	D55	N.A.	80.00	80.00
<b>Container, Litter:</b> Color-Keyed					
	0 0	D24	N.A.	6.00	6.00
<b>Cover, Cargo Box Tonneau:</b> Not available when D73 Cargo Rails are specified					
Black	0 8	19K	N.A.	103.00	103.00
White	0 8	11K	N.A.	103.00	103.00
<b>Emission Systems: Dealer Note</b> – One of the following emission options must be specified.					
<i>California Emission Requirements.</i> Includes all testing, equipment and /or certification necessary for registration in the State of California. (See Power Teams Chart for availability and specifications)					
	13 0	YF5	N.A.	75.00	75.00
<i>High Altitude Emission Equipment.</i> Available only when LM1 350 Cu. In. Engine and MX1 Automatic Transmission are specified.					
	0 0	NA6	N.A.	33.00	33.00
<i>Standard Emission Equipment.</i>					
	0 0	NA2	NO ADDITIONAL CHARGE		
<b>Floor Covering: Mats, Color-Keyed Floor.</b> 2 Front.					
	4 2	B32	N.A.	11.00	11.00
<b>Gage Package:</b> Includes voltmeter, temperature and oil pressure gages and U35 Electric Clock mounted on instrument panel. Not available when U14 Instrumentation is specified.					
	1 0	UF7	N.A.	53.00	53.00
<b>Generator, 61-Amp Delcotron:</b> Included when C60 air conditioning is specified					
	1 0	K76	N.A.	31.00	31.00
<b>Glass: Soft-Ray Tinted.</b> All windows					
	0 0	A01	N.A.	62.00	62.00
<b>Instrumentation: Special.</b> Includes tachometer, voltmeter, temperature and oil pressure gages and U35 Electric Clock. Not available when UF7 Gage Package is specified.					
	2 0	U14	N.A.	118.00	118.00
<b>Lighting, Auxiliary:</b> Includes headlamp warning buzzer; courtesy and underhood lights.					
	1 0	ZJ9	N.A.	23.00	23.00

§ D&H amounts reflect provision for pass through of tire weight tax imposed on manufacturer or importer of tires.

◊ State and local taxes not included.

# EL CAMINO

## OPTIONS AND ACCESSORIES WHEN INSTALLED BY CHEVROLET

Prices shown are effective with vehicles produced on or after February 6, 1978

Description	Added Weight		Option Number	Factory D&H <sup>§</sup>	List Price	Mfr's Suggested Retail Price ◊
	(F)	(R)				
<b>OTHER OPTIONS</b>						
<b>Mirrors:</b>						
<i>Outside Rearview, LH Remote.</i> Not available when Z15 Super Sport is specified.	1	0	D33	N.A.	16.00	16.00
<i>Sport, LH Remote and RH Manual.</i> Included when Z15 Super Sport is specified.	2	2	D35	N.A.	33.00	33.00
<i>Sport, Twin Remote</i>						
Without Z15 Super Sport	2	1	D68	N.A.	57.00	57.00
With Z15 Super Sport	2	1	D68	N.A.	24.00	24.00
<i>Visor Vanity.</i>	0	0	D34	N.A.	4.00	4.00
<i>Visor Vanity, Illuminated.</i>	0	0	D64	N.A.	37.00	37.00
<b>Moldings:</b>						
<i>Body Side, Deluxe</i> Not available when Z15 Super Sport or D91 Conquista is specified.	0	1	BW2	N.A.	53.00	53.00
<i>Door Edge Guard.</i>	0	0	B93	N.A.	11.00	11.00
<i>Front Fender, Body Side and Tailgate.</i> Not available when Z15 Super Sport is specified. Included when D91 Conquista is specified.	1	2	BX8	N.A.	48.00	48.00
<b>Paints, Exterior:</b> See Interior and Exterior Color Selection Chart for ordering information.						
<i>Solid.</i>	0	0			NO ADDITIONAL CHARGE	
<b>Radiator, Heavy-Duty:</b>						
Without LD5 Engine.	6	1	V01	N.A.	31.00	31.00
With LD5 Engine	4	-1	V01	N.A.	31.00	31.00
<b>Radio Equipment:</b>						
<i>AM Radio.</i>	5	2	U63	N.A.	79.00	79.00
<i>AM /FM Radio.</i>	6	2	U69	N.A.	149.00	149.00
<i>AM /FM Stereo Radio.</i>	11	4	U58	N.A.	229.00	229.00
<i>Stereo Tape System with AM Radio.</i>	13	4	UM1	N.A.	233.00	233.00
<i>Stereo Tape System with AM /FM Stereo Radio.</i>	13	4	UM2	N.A.	328.00	328.00
<i>Speakers, Dual Front.</i> Included when U58, UM1 or UM2 Radio is specified.	0	0	UX6	N.A.	20.00	20.00
<i>Windshield Antenna.</i> Included when radios are specified without U75 Power Antenna.	0	0	U76	N.A.	25.00	25.00
<i>Power Antenna.</i> Available only when Radio is specified.	4	0	U75	N.A.	45.00	45.00
<b>Rails, Cargo Box Side</b>	0	6	D73	N.A.	73.00	73.00
<b>Roof Cover, Vinyl:</b> Not available when D91 Conquista is specified. Includes bright metal outline molding. See Interior and Exterior Color Selection Chart.	1	1		N.A.	72.00	72.00
<b>Roof Cover, Vinyl:</b> Available only when D91 Conquista is specified. See Interior and Exterior Color Selection Chart.	1	1	ZK9	N.A.	72.00	72.00
<b>Seat Trim:</b> See Interior and Exterior Color Selection Chart for availability and ordering information.						
<i>P**1 Knit Cloth Bench.</i>	0	0			NO ADDITIONAL CHARGE	
<i>P**3 Knit Cloth 50 /50.</i>	0	0		N.A.	164.00	164.00
<i>V**1 Vinyl Bench.</i>	0	0		N.A.	24.00	24.00
<i>V**2 Vinyl Buckets.</i>	5	5		N.A.	110.00	110.00
<i>V**3 50 /50</i>	0	0		N.A.	188.00	188.00
<b>Speed Control: Cruise-Master.</b> Available only when MX1 Automatic Transmission is specified.	5	0	K30	N.A.	90.00	90.00
<b>Steering Wheel: Comfortilt.</b>	2	0	N33	N.A.	69.00	69.00
<b>Suspension Equipment: Suspension</b> Available only when V8 Engine is specified						
<i>Heavy-Duty Front and Rear.</i>	1	0	F40	N.A.	20.00	20.00
<i>Sport</i>	0	8	F41	N.A.	11.00	11.00
<b>Tank, Fuel: 22 gallons</b>	-1	6	N23	N.A.	21.00	21.00
<b>Tie-Downs, Cargo Box</b>	0	1	AV3	N.A.	18.00	18.00

§ D&H amounts reflect provision for pass through of tire weight tax imposed on manufacturer or importer of tires.  
 ◊ State and local taxes not included.





# **EL CAMINO**

## **CAB & BODY FEATURES COLOR & TRIM CHARTS TWO-TONES**

# EL CAMINO

## STANDARD EL CAMINO CLASSIC MODEL

The Standard model includes the following items as standard equipment.

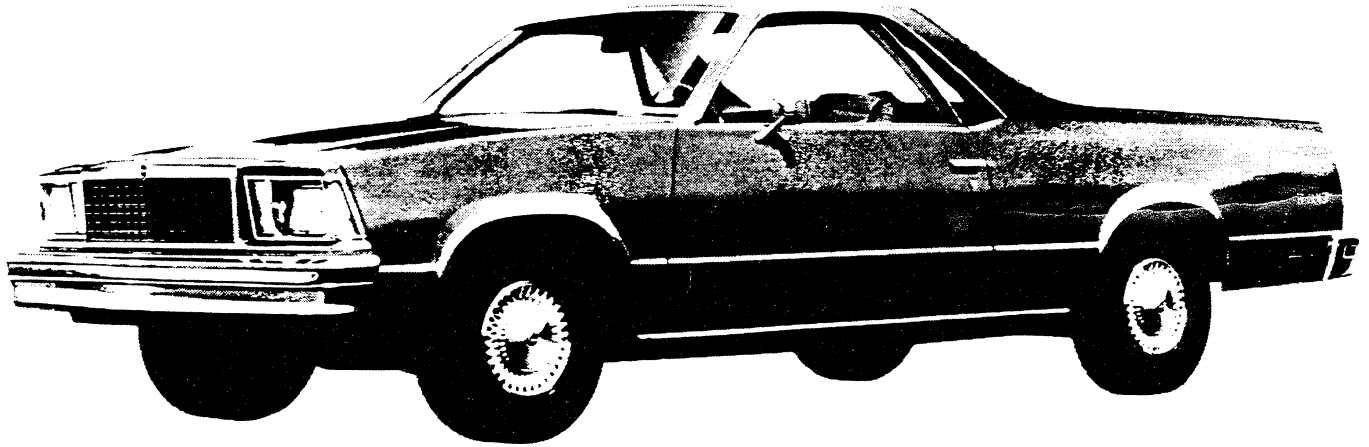

### EXTERIOR

- **Bright Appearance Items:**

- "CHEVROLET" letters: on LH side of grille header panel
- Chevrolet Bow Tie emblem: On center of grille header panel and at upper center of tailgate
- "El Camino" nameplates: Sides of rear fenders
- Chrome front and rear bumpers
- Door lock cylinder covers
- Door lock handles
- Grille and moldings
- Headlight bezels
- Headlamp, parking lamp and marker lamp moldings
- LH side rearview mirror
- License pocket moldings
- Pickup box, rear sail panel and roof moldings
- Quarter window moldings
- Rear marker lamp moldings
- Rocker panel moldings
- Roof drip moldings
- Side door belt bead moldings
- Wheel covers
- Wheel opening moldings
- Windshield and back window reveal moldings

- **Color:** See Interior and Exterior Color Selection Chart

- **Door Opening and Locking Methods:**

- Side doors; lift bar latch release with key lock cylinder
- Tailgate; single pivot handle on inside surface of tailgate, double latch

- **Doors:** RH and LH side doors and tailgate
- **Glass:** Windshield, drop glass in each side door, side quarter windows, and back glass
- **Grille:** Plastic grid; chrome plated
- **Horn:** Dual note
- **Lights:**
  - Combination parking direction. Two front; single lens
  - Combination tail/stop/direction and backup, integral with bumper
  - Headlights. Two; single rectangular, with integral side marker and reflectors
  - License plate. Single rear
  - Side marker and reflectors. 2 rear, quarter panel mounted
- **Mirror:** LH chrome fixed arm with 5" rectangular head
- **Side Door Beams:** Steel beam running full width inside each side door
- **Tools:** Mechanical jack; wheel wrench
- **Wheels:** 14" x 6"; 5 bolt, 4 $\frac{3}{4}$ " bolt circle
- **Windshield Wipers and Washers:** Electric; 2-speed wipers Hide-A-Way blades and arms

# EL CAMINO

## STANDARD EL CAMINO CLASSIC MODEL

The Standard model includes the following items as standard equipment.

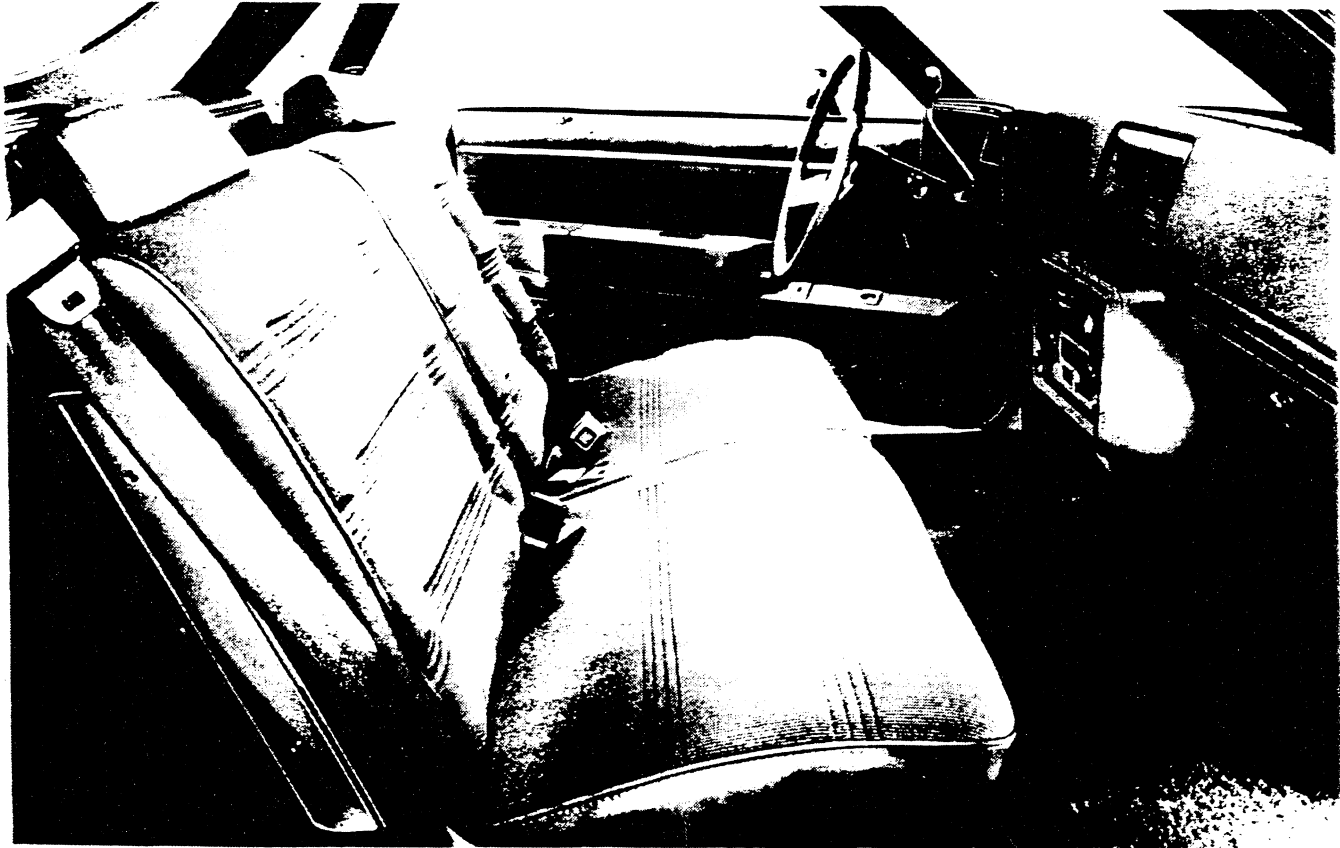

### INTERIOR

- **Air Vents:** RH and LH cowl side; individually controlled
- **Armrests:** RH and LH full padding
- **Ashtray:** Lighted
- **Carpeting:** Color-keyed nylon cut pile
- **Cigarette Lighter**
- **Colors, Interior:**  
See Interior Color Selections Charts
- **Courtesy Light Switches:** Door-actuated
- **Door Locks:** Inside; bright pushbutton lock/release
- **Door Seals:** Closed-cell-type rubber
- **Flow-through ventilation system**
- **Glove Compartment:** Lighted
- **Headliner:** Cloth over foam padding
- **Heater and Defroster:** Deluxe-air
- **Instruments:**  
Gauges: Speedometer, odometer and fuel  
Switches: Exterior lights, instrument lights, dome light, wiper-washer, headlight beam (column operated), ignition, directional signal with lane change position, hazard warning and heater  
Warning Lights: Generator, oil pressure, engine temperature, brake warning, seat belt, direction signals and high beam
- **Instrument Panel:** Fiberglass filled plastic; energy absorbing
- **Instrument Panel Knobs:** Black; aluminum faced
- **Insulation and Sound Deadening:** Dash (firewall), under floor mat and other strategic points
- **Interior Lights:** Instrument and dome operated by main light switch
- **Mirror, Rearview:** Inside; 10" wide
- **Scuff Plates:** Side door opening protection and floor mat retainer
- **Seat:** Full width, choice of cloth or textured all-vinyl trim
- **Seat and Shoulder Belts:** 3 sets of seat belts; 2 shoulder belts in outboard positions; includes warning light and buzzer
- **Spare Tire and Carrier:** Stored horizontally behind seat passenger side
- **Steering Lock:** Column-mounted combination ignition switch, transmission lock, steering lock and accessory switch
- **Steering Wheel:** Color-keyed grained plastic; soft rim with vinyl insert. "Chevrolet" name on shroud; energy absorbing, locking column
- **Sunshades:** RH and LH padded vinyl
- **Trim Panels:** Cloth/vinyl door trim panels with bright trim vinyl-coated cowl side panels and cloth/foam padded heel liner
- **Warning Buzzer:** Ignition key removal warning; activated on opening side door with key in switch; seat belt
- **Window Regulator Knobs:** Clear plastic
- **Windshield Pillar Pads**

# EL CAMINO

## EL CAMINO SUPER SPORT MODEL

The Super Sport model includes all items listed for the Standard model plus the following additions or substitutions.

### EXTERIOR

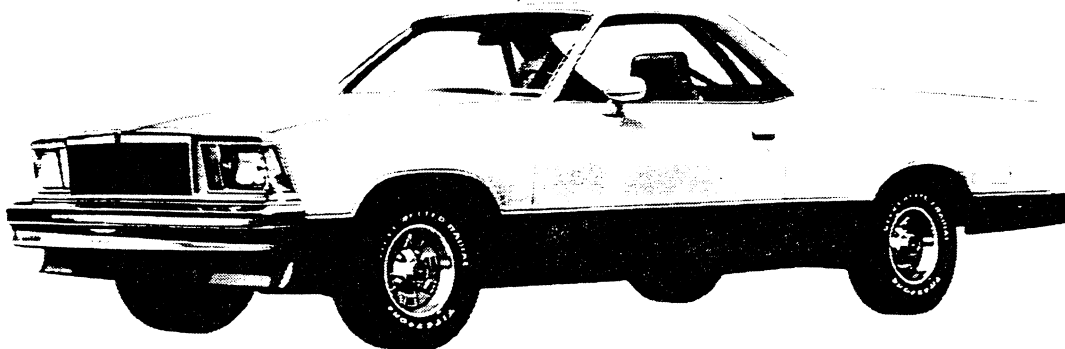

- **Bright Appearance Items:**
  - Delete wheel opening and rocker panel moldings
- **Front Air Dam:** Replaces standard air deflector
- **Grille:** Special black paint treatment on grille
- **Mirrors:** Sport type, LH and RH, painted upper body color
- **Ornamentation:** "Super Sport" decals on lower portion of doors and on tailgate. Vinyl pinstriping decal to cover paint break lines.
- **Quarter Window Moldings:** Black
- **Paint:** Accent paint color on lower body.
- **Rally Wheels:** Painted to match lower body color

---

## EL CAMINO CLASSIC WITH CONQUISTA OPTION—RPO D91

(This option includes all items listed for the standard model plus the following additions or substitutions)

### EXTERIOR

- **Black painted door belt and quarter window moldings**
- **Bright paint break moldings on front fender, bodyside and tailgate**
- **"Conquista" decal on RH lower portion of tailgate**
- **Special two-tone paint**

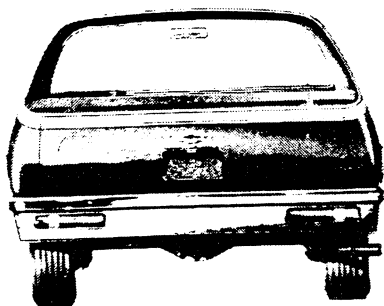
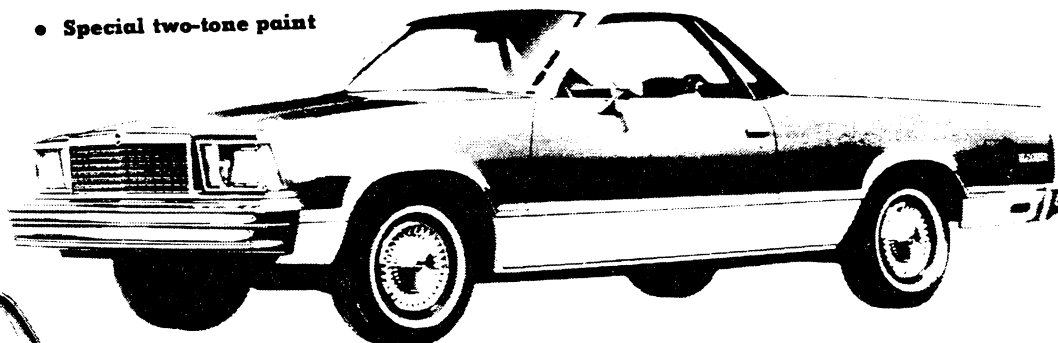

# EL CAMINO

## DIMENSIONS

The El Camino pickup box features double-wall construction on the side panels and a ribbed all-steel floor. The tailgate, featuring easy, one-hand operation and grain-tight seal also has double-wall construction and forms a continuation of the ribbed floor when lowered. The pickup box has a capacity of approximately 35.5 cubic feet.

All El Camino models have a bright metal molding at the top of the box and tailgate to prevent paint chipping when loading or unloading.

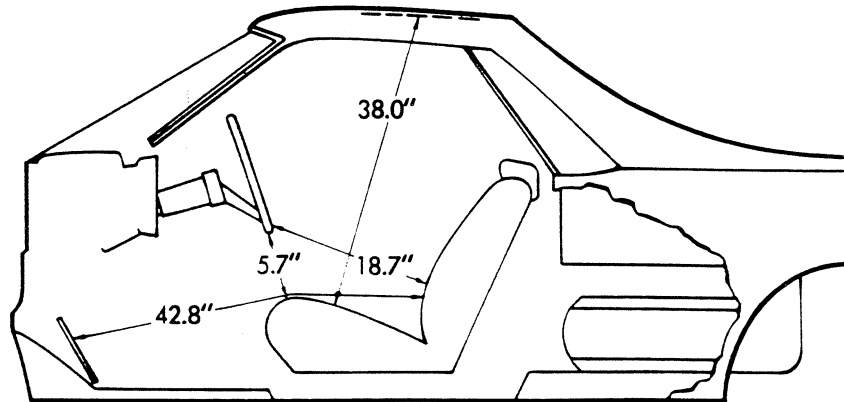
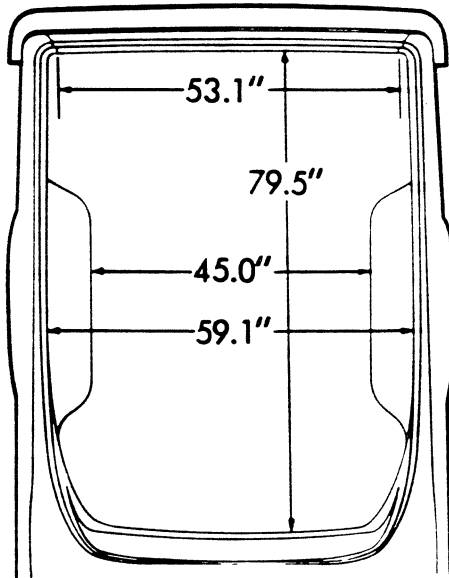
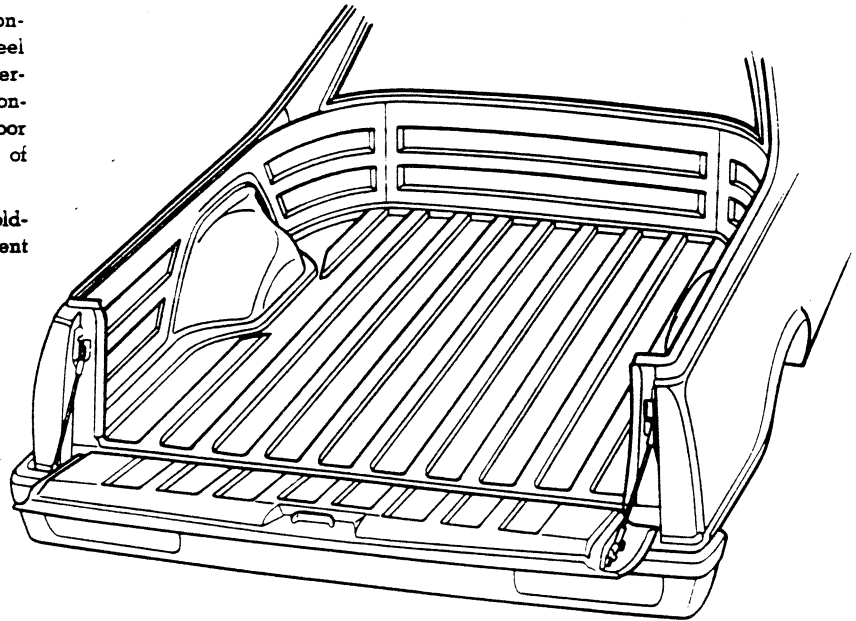

**CAB DIMENSIONS\***

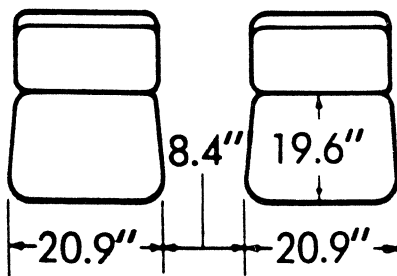

**BUCKET SEATS**

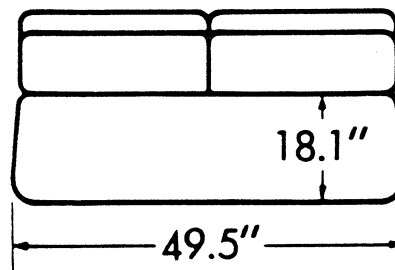

**BENCH SEAT**

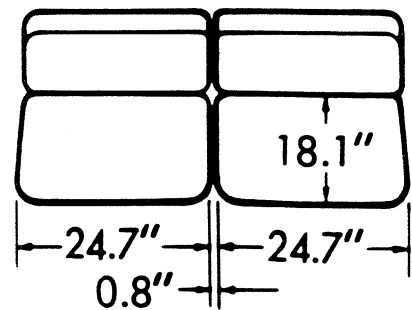

**50/50 SEAT**

\*All interior dimensions measured with seat in rear position.

# EL CAMINO CLASSIC

## INTERIOR AND EXTERIOR COLOR COMBINATIONS

**PLEASE NOTE:** The exterior and interior combinations shown in the chart below and designated as recommended (R), represent the ideal combinations. Those that are shown as acceptable (A), are attractive, but less desirable than the recommended combinations. Orders for additional combinations may be submitted, provided the dealer initials the appropriate order form box (ZP2), as verification that the requested combination is definitely desired.

**CAUTION:** Please utilize available color samples when ordering, especially when adding a third color element (Vinyl Top, Exterior Color, Interior Trim) in order to avoid undesirable combinations.

VINYL ROOF	CODE	EXTERIOR COLOR AVAILABILITY	
		RECOMMENDED	ACCEPTABLE
Black	BB	11, 15, 19, 61 or 67	21, 22, 29, 44, 45, 63, 77 or 79
Blue, Light (Metallic)	DD	11, 21, 22 or 29	19
Camel, Light	CC	61, 63 or 69	11, 19 or 67
Carmine, Dark (Metallic)	RR	79	77
Green, Light (Metallic)	GG	11, 44 or 45	19
Silver	QQ	15 or 19	77
White	WW	All except 15, 61, 69 or 79	15, 61, 69 or 79

INTERIOR TRIM COLORS AND CODES						
Seat, Headliner and Door Trim Color		Black	Blue	Camel	Carmine	Green
Instrument Panel Pad and Carpet Color		Black	Blue	Camel	Carmine	Green
MODEL	SEAT TYPE					
El Camino Classic (Standard Model)	Knit Cloth Bench	PBB1	PDD1	PCC1	PRR1	PGG1
	Knit Cloth 50/50	PBB3	PDD3	PCC3	PRR3	PGG3
	Vinyl Bench	VBB1	VDD1	VCC1	VRR1	
	Vinyl Bucket		VDD2	VCC2	VRR2	
	Vinyl 50/50	VBB3			VRR3	
EXTERIOR PAINT COLOR	COLOR CODE					
	Lower	Upper				
Black	19	19	R	A	R	R
Blue, Dark (Metallic)	29	29	A	R	A	
Blue, Light (Metallic)	22	22	A	R		
Blue, Light	21	21	A	R		
Camel (Metallic)	63	63	A		R	
Camel, Dark (Metallic)	69	69	A		R	
Camel, Light	61	61	R		R	A
Carmine (Metallic)	77	77	A		A	R
Carmine, Dark (Metallic)	79	79	A		A	R
Green, Light (Metallic)	44	44	A		A	R
Green, Medium (Metallic)	45	45	A		A	R
Saffron (Metallic)	67	67	R		A	R
Silver (Metallic)	15	15	R	A		R
White	11	11	R	R	R	R

R—Recommended  
A—Acceptable

# EL CAMINO SUPER SPORT

## INTERIOR AND EXTERIOR COLOR SELECTION CHART

**PLEASE NOTE:** The exterior and interior combinations shown in the chart below are the only combinations that are available (ZP2 override not permitted).

INTERIOR TRIM COLORS AND CODES											
Seat, Headliner and Door Trim Color						Black	Blue	Camel	Carmine		
Instrument Panel Pad Color and Carpet Color						Black	Blue	Camel	Carmine		
MODEL	SEAT TYPE										
El Camino Super Sport	Knit Cloth Bench					PBB1	PDD1	PCC1	PRR1		
	Knit Cloth 50/50					PBB3	PDD3	PCC3	PRR3		
	Vinyl Bench					VBB1	VDD1	VCC1	VRR1		
	Vinyl Bucket						VDD2	VCC2	VRR2		
	Vinyl 50/50					VBB3			VRR3		
EXTERIOR PAINT COLOR	COLOR CODE		LOWER PAINT ACCENT COLOR AND ORDERING CODE #		DECAL OUTLINE AND LETTERING COLORS*					VINYL TOP CO AVAILABILITY (IF SPECIFIED)	
	Lower	Upper									
Black	19	19	Carmine (M)	77M	Red/Black	R			R	BB	
Black	19	19	Gold (M)	56M	Gold/Gold	R		R		BB or CC	
Black	19	19	Silver	15M	Red/Black	R			R	BB or QQ	
Blue, Dark (M)	29	29	Black	19M	Blue/Black	R	R			BB or DD	
Blue, Light (M)	22	22	Black	19M	Blue/Black	R	R			BB or DD	
Camel (M)	63	63	Black	19M	Gold/Black	R		R		BB	
Camel, Dark (M)	69	69	Black	19M	Gold/Gold	R		R		BB or CC	
Camel, Dark (M)	69	69	Gold (M)	56M	Gold/Gold	R		R		CC	
Camel, Light	61	61	Gold (M)	56M	Gold/Gold			R		CC	
Carmine, Dark (M)	79	79	Black	19M	Red/Black	R			R	RR	
Carmine (M)	77	77	Black	19M	Red/Black	R			R	BB	
Carmine (M)	77	77	Carmine, Dark (M)	79M	Red/Black	R			R	RR	
Saffron (M)	67	67	Black	19M	Red/Black	R				BB	
Silver (M)	15	15	Black	19M	Red/Black	R			R	QQ or BB	
Silver (M)	15	15	Carmine (M)	77M	Red/Black	R			R	QQ	
Silver (M)	15	15	Gray (M)	16M	Red/Black	R			R	QQ	
White	11	11	Black	19M	Red/Black				R	WW or BB	
White	11	11	Black	19M	Blue/Black	R	R			WW or BB	
White	11	11	Black	19M	Gold/Black			R		WW or BB	
White	11	11	Gold (M)	56M	Black/Gold			R		WW or CC	

R—Recommended

(M)—Metallic

\*Color determined by exterior color, lower accent color and interior trim combination

#Must be ordered. Specify choice in option portion of order form.

# EL CAMINO CONQUISTA

## INTERIOR AND EXTERIOR COLOR COMBINATIONS

**PLEASE NOTE:** The exterior and interior combinations shown in the chart below are the only combinations that are available (ZP2 override not permitted).

INTERIOR TRIM COLORS AND CODES										
Seat, Headliner and Door Trim Color				Black	Blue	Camel	Carmine	Green		
Instrument Panel Pad and Carpet Color				Black	Blue	Camel	Carmine	Green		
MODEL	SEAT TYPE									
El Camino Classic (with Conquista option D91)	Knit Cloth Bench			PBB1	PDD1	PCC1	PRR1	PGG1		
	Knit Cloth 50/50			PBB3	PDD3	PCC3	PRR3	PGG3		
	Vinyl Bench			VBB1	VDD1	VCC1	VRR1			
	Vinyl Bucket				VDD2	VCC2	VRR2			
	Vinyl 50/50			VBB3			VRR3			
HOOD AND CENTER BODY	LOWER	ROOF AND LOWER BODY	UPPER							VINYL ROOF (ZK9) (IF SPECIFIED)#
Black	19	Gold (M)	56	R		R				Black
Black	19	Silver (M)	15	R		A				Black
Blue, Light (M)	22	Blue, Dark (M)	29	A	R					Blue, Light (M)
Camel (M)	63	Camel, Light	61	A		R				Light Camel
Carmine (M)	77	Carmine, Dark (M)	79	A		A	R			Carmine, Dark (M)
Carmine (M)	77	White	11	A			R			White
Green, Med. (M)	45	White	11	A				R		White
Saffron (M)	67	White	11	R		R				White
Silver (M)	15	Carmine (M)	77	A			R			Silver
Silver (M)	15	Gray, Medium (M)	16	R			R			Silver
White	11	Blue, Light (M)	22	A	R					White
White	11	Gold (M)	56	A		R				White

#If vinyl roof is desired, order as option ZK9. Vinyl roof color is determined by exterior paint combination selected.  
 (M) Metallic (R) Recommended (A) Acceptable

### CONQUISTA TWO-TONE PAINT—D91 Primary Hood and Center Body Color

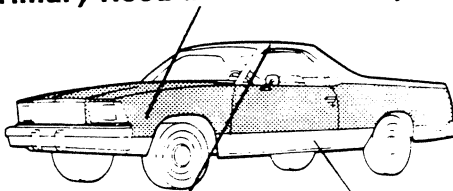

Secondary Roof and Lower Body Color



C.O. No.

Subject

EL CAMINO "BLACK KNIGHT"



CHEVROLET MOTOR DIVISION  
General Motors Corporation  
Central Office  
Detroit, Michigan 48216

To REGIONAL AND ZONE MANAGERS

Date

This is to announce the limited edition "Black Knight" El Camino, RPO Z16, which is designed to be a Dealer traffic builder at the beginning of the traditionally strong spring selling season. The "Black Knight" is a striking variation of the El Camino "Super Sport" and includes many of its features.

The unique "Black Knight" treatment builds on the "Super Sport" package, RPO Z15, which must be specified on Dealer orders. Included is solid black paint, tri-tone gold pin striping on the sides and tailgate, "Black Knight" lettered decals on the lower front fender and the lower right hand portion of the tailgate (all exterior "Super Sport" designation is eliminated), black side window reveal moldings, and a gold graphic decal on the hood.

"Black Knight" orders may be submitted immediately through normal distribution channels within Zone and Dealer allocations. Order and price information will be furnished by the Distribution Department through regular channels. Additional information can be found in Attachment "A".

"Black Knight" is a distinctive truck that will draw additional attention to the entire truck lineup, when displayed and aggressively promoted by Dealers.

Questions regarding the El Camino "Black Knight" should be directed to Mr. F. F. Raine, Jr. of this department.

Very truly yours,

L. P. SCHINZING  
Manager  
Truck Merchandising

cc:Rs  
Attachment

C. O. Asst. Managers & Administrators-Truck Mdsgr.  
Regional Heavy Duty Truck Sales Engineers  
Zone Merchandising Managers-Trucks  
Zone Truck Sales Engineers  
National Account Executives (Fleet)  
Regional Fleet Account Executives  
Regional Fleet Representatives

ADDITIONAL INFORMATION

1978 EL CAMINO "BLACK KNIGHT"

RPO Z16\*

"BLACK KNIGHT" FEATURES:

- SOLID BLACK EXTERIOR PAINT COLOR (ONLY)
- INTERIOR TRIM IS LIMITED TO BLACK OR CAMEL (RE: DEALER ORDER GUIDE)
- TRI-TONE GOLD PIN STRIPING ON BODY SIDES AND TAILGATE
- "BLACK KNIGHT" LETTERED DECALS ON LOWER FRONT FENDER AND LOWER RIGHT HAND PORTION OF TAILGATE (ALL EXTERIOR "SUPER SPORT" DESIGNATION IS ELIMINATED)
- "BLACK KNIGHT" GRAPHIC DECAL ON HOOD

Z15 "SUPER SPORT" FEATURES INCLUDED WITH "BLACK KNIGHT" OPT

- FRONT AIR DAM
- D35 SPORT MIRRORS
- SPECIAL BLACK PAINT TREATMENT ON GRILLE
- TRI-TONE PIN STRIPING ON LOWER BODY AND OVER WHEEL OPENING
- GOLD RALLY WHEELS
- BLACK QUARTER WINDOW MOLDINGS
- "EL CAMINO SS" NAMEPLATE ON INSTRUMENT PANEL

OPTIONS NOT AVAILABLE WITH "BLACK KNIGHT":

- BODY SIDE MOLDINGS (BW2)
- CONQUISTA DECOR EQUIPMENT (D91)
- WIRE WHEEL TRIM COVERS (N95)
- SILVER SPORT WHEEL COVERS (PB2)

NOTE: \* RPO Z16 REQUIRES THAT RPO Z15 BE INCLUDED ON DEALER ORDERS.

## ✓ ALPHABETICAL OPTION INDEX (Not for Ordering Purposes)

<u>Option Number</u>	<u>Description</u>	<u>Option Number</u>	<u>Description</u>
AK1	BELTS, DELUXE: Color-Keyed Seat and Shoulder	PB2	WHEEL TRIM: wheel Covers, Sport (Silver)
AU3	DOOR LOCK SYSTEM, POWER	QKH	TIRES: P205/75 R-14-B Blackwall (Radial)
AV3	TIE-DOWNS, CARGO BOX	QKJ	TIRES: P205/75 R-14-B Whitewall (Radial)
A01	GLASS, SOFT-RAY TINTED: All Windows	QKK	TIRES: P205/75 R-14-B White Lettered (Radial)
A31	WINDOWS: Power	UA1	BATTERY, HEAVY-DUTY
A42	SEAT, POWER: Six-Way	UF7	GAGE PACKAGE
BW2	MOLDINGS: Body Side, Deluxe	UM1	RADIO EQUIPMENT: Stereo Tape System w/AM Radio
BX8	MOLDINGS: Front Fender, Body Side and Tailgate	UM2	RADIO EQUIPMENT: Stereo Tape System w/AM/FM Stereo Radio
B32	FLOOR COVERING: Mats, Color-Keyed Floor	JX6	RADIO EQUIPMENT: Speakers, Dual Front
B93	MOLDINGS: Door Edge Guards	U14	INSTRUMENTATION: Special
CD4	WINDSHIELD WIPER EQUIPMENT: Intermittent System	U35	CLOCK: Electric
C60	AIR CONDITIONING: Four-Season	U58	RADIO EQUIPMENT: AM/FM Stereo Radio
D24	CONTAINER, LITTER	U63	RADIO EQUIPMENT: AM Radio
D33	MIRROR: Outside Rearview, LH Remote	U69	RADIO EQUIPMENT: AM/FM Radio
D34	MIRROR: Visor Vanity	U75	RADIO EQUIPMENT: Power Antenna
D35	MIRRORS: Sport, LH Remote and RH Manual	U76	RADIO EQUIPMENT: Windshield Antenna
D55	CONSOLE	VE5	BUMPER EQUIPMENT: Bumper Rub Strips
D64	MIRROR: Visor Vanity, Illuminated	V01	RADIATOR, HEAVY-DUTY
D68	MIRRORS: Sport, Twin Remote	V30	BUMPER EQUIPMENT: Bumper and Guards. Front and Rear
D73	RAILS, CARGO BOX SIDE	YF5	EMISSION SYSTEMS: California Emission Requirements
D91	CONQUISTA	ZJ7	WHEEL TRIM: wheels, Rally. Color-Keyed
F40	SUSPENSION EQUIPMENT: Suspension Heavy-Duty Front and Rear	ZJ9	LIGHTING, AUXILIARY
F41	SUSPENSION EQUIPMENT: Suspension Sport	ZK9	ROOF COVER, CONQUISTA VINYL
G80	AXLE, REAR: Positraction	ZP2	EXTERIOR/INTERIOR OVERRIDE
G92	AXLE, REAR: Performance Ratio	Z15	SUPER SPORT (Model Option)
K30	SPEED CONTROL: Cruise-Master	Z16	BLACK KNIGHT
K76	GENERATOR: 61-Amp Delcotron	11K	COVER, CARGO BOX TONNEAU: white
LD5	ENGINE: 231 Cu. In. V6	19K	COVER, CARGO BOX TONNEAU: Black
LG3	ENGINE: 305 Cu. In. V8	15M	ACCENT COLOR: Silver Metallic
LM1	ENGINE: 350 Cu. In. V8	16M	ACCENT COLOR: Gray Metallic
L26	ENGINE: 3.3 Litre (200 Cu. In.) V6	19M	ACCENT COLOR: Black
MM3	TRANSMISSION: 3-Speed Manual	56M	ACCENT COLOR: Gold Metallic
MM4	TRANSMISSION: 4-Speed Manual	77M	ACCENT COLOR: Carmine Metallic
MX1	TRANSMISSION: Automatic	79M	ACCENT COLOR: Dark Carmine Metallic
NA2	EMISSION SYSTEMS: Standard Emission Equipment	55P	WHEEL TRIM: wheel Covers, Sport (Gold)
NA6	EMISSION SYSTEMS: High Altitude Emission Equipment	19Q	MOLDINGS: Black
N23	TANK, FUEL: 22 Gallons	22Q	MOLDINGS: Light Blue
N33	STEERING WHEEL: Comfortilt	44Q	MOLDINGS: Light Green
N41	STEERING, POWER	61Q	MOLDINGS: Light Camel
N95	WHEEL TRIM: Wheel Covers, Wire	79Q	MOLDINGS: Dark Carmine

# EL CAMINO CONQUISTA

## COLOR AND TRIM SELECTION

PLEASE NOTE: The exterior and interior combinations shown in the chart below are the only combinations that are available. (ZP2 override not permitted)

Seat, Headliner, and Door Trim Color	Black	Blue	Camel	Car- mine	Green
Instrument Panel Pad and Carpet Color	Black	Blue	Camel	Car- mine	Green

Model	Seat Type					
14WJ0/D91	Knit Cloth Bench	PBB1	PDD1	PCC1	PRR1	PGG1
	Knit Cloth 50/50	PBB3	PDD3	PCC3	PRR3	PGG3
	Vinyl Bench	PBB1	VDD1	VCC1	VRR1	
	Vinyl Bucket		VDD2	VCC2	VRR2	
	Vinyl 50/50	PBB3			VRR3	

Roof and Center Body	Roof and Lower Body					Vinyl Roof (ZK9) If Specified
Black	12 Gold	50	-			Black
Black	19 Silver	19	-			Black
Blue, (Met)	20 Blue, Dark (Met)	20	-			Light Blue (Met)
Camel	21 Camel, Light	21	-			Light Camel
Car-mine (Met)	22 Car-mine, Dark (Met)	22	-			Dark Car-mine (Met)
Car-mine (Met)	23 White	23	-			White
Green, (Medium (Met)	24 White	24	-			White
Platinum (Met)	27 White	27	-			White
Silver	15 Car-mine (Met)	27	-			Silver
Silver	13 Gray, (Medium (Met)	16	-			Silver
White	11 Blue, Light (Met)	22	-			White
White	11 Gold (Met)	56	A			White

L=Lower U=Upper

\* If Vinyl Roof is desired, order as Option ZK9. Vinyl Roof color is determined by Exterior Paint combination selected.

### CONQUISTA TWO-TONE PAINT-D91 Primary Hood and Center Body Color

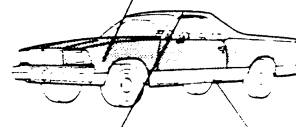

= Secondary Roof and Lower Body Color

\* Refer above chart for roof color when ZK9 Vinyl Roof is specified.

## POWER TEAMS

(Refer to next page for option availability and application)

ENGINE OPTION CONDITION	AXLE RATIO	
	2.41	2.73
WITHOUT YES CALIFORNIA OR NA6 HIGH ALTITUDE EMISSION		
L26 4M3 or MX1	-	Std
LG3 4M4	-	Std
	Std	G92
LM1 4M4	-	Std
	Std	G92
WITH YES CALIFORNIA		
LD5 4X1	-	Std
LG3 4X1	Std	G92
LM1 4X1	Std	G92
WITH NA6 HIGH ALTITUDE EMISSION		
LM1 4X1	-	Std

# EL CAMINO CONQUISTA

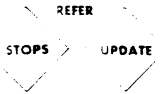

**Model**

1AW80 El Camino Conquista

## ← COLOR AND TRIM SELECTION

**MUST ORDER ONE: \_\_\_\_\_ ENGINES \_\_\_\_\_**

- AVAILABLE WITH-NA2 STANDARD EMISSION EQUIPMENT**
- \_\_\_ L26 3.3 Litre (200 Cu. In.) V6 (Reqs MM3 or MX1 Trans)
  - ✓ LG3 305 Cu. In. V8 (Reqs N41 Steering) (N/A MM3 Trans)
  - ✓ LM1 350 Cu. In. V8 (Reqs N41 Steering) (N/A MM3 Trans)

- AVAILABLE WITH-NA6 HIGH ALTITUDE EMISSION EQUIPMENT**  
(Recommended Above 4000 Foot Altitude)
- ✓ LM1 350 Cu. In. V8 (Reqs N41 Steering and MX1 Trans)

- CALIFORNIA REGISTRATION (REQS YF5)**
- ✓ LD5 231 Cu. In. V6 (Reqs MX1 Trans)
  - ✓ LG3 305 Cu. In. V8 (Reqs N41 Steering and MX1 Trans)
  - ✓ LM1 350 Cu. In. V8 (Reqs N41 Steering and MX1 Trans)

496 D91 Feature Option:  
Conquista

**✓ QUICK-SPEC**

**IF TIRE AND/OR TRANSMISSION IN QUICK-SPEC IS NOT DESIRED YOU MUST "PLUS" ANOTHER TIRE AND/OR TRANSMISSION OPTION.**

Conquista	D91	X	X	X	X	X	
Transmission, Automatic	MX1	X	X	X	X	X	
Glass, Soft-Ray Tinted	A01	X	X	X	X	X	
Radio, AM	U63	X	X	N/INCL			
Air Conditioning, Four-Season	D50	X	X	X	X	X	
Tires, P205/75 R-14-B							
White Stripe	DKJ	X	X	X	X	X	
Console (w/ Bucket Seats only)	D55	X	X	X	X	X	
Mats, Color-Keyed Floor	B32	X	X	X	X	X	
Steering, Power	N41	X	X	X	X	X	
Wheels, Rally	D07	X	X	X	X	X	
-----							
Bumper Guards	U55	X	X	X	X	X	
Clock, Electric	U35	X	N/INCL				
Mirrors, LH Remote and RH Manual Sport	D68	X	X	X			NOT INCL
Moldings, Door Edge Guard	B93	X	X	X	X	X	
Steering wheel, Comfortilt	N33	X	X	X	X	X	
Belts, Deluxe	AK1	X	X	X	X	X	
Bumper Rub Strips	U65	X	X	X	X	X	
-----							
Radiator, Heavy-Duty	V01	X	X	X			NOT INCL
Radio, AM/FM	U69	X	X				
Lighting, Auxiliary	D09	X	X	X			
Speed Control (w/MX1 Trans Only)	K30	X	X	X			
Sage Package	U67	X	N/INCL				
Tank, Fuel	N23	X	X	X			
-----							
Door Lock System, Power	A03	X	X				
Rails, Cargo Box Side	D73	X	X				
Windows, Power	A31	X	X				
W/S Wiper Equip, Intermittent	CD4	X	X				
Instrumentation	J14	X	X				
-----							
Mirror, Visor Vanity	D34	X					
Container, Litter	CD4	X					
Radio, AM/FM Stereo	U58	X					
Power Antenna	U75	X					
Mirrors, Twin Remote Sport	D68	X					

**PLEASE REVIEW OPTION RESTRICTIONS BEFORE ORDERING**

496	✓ U60	<b>AIR CONDITIONING:</b> Four-Season (LD5 or L26 Eng Reqs N41 Steering) (Incls K76 Gen)
		<b>AXLES, REAR:</b>
	992	--Performance Ratio (See Power Teams Chart) (Reqs V8 Eng and MX1 Trans)
	980	--Positraction
	UA1	<b>BATTERY, HEAVY-DUTY</b>
497	AK1	<b>BELTS, DELUXE:</b> Color-Keyed Seat and Shoulder
		<b>BUMPER EQUIPMENT:</b> Front and Rear
497	U65	--Bumper Rub Strips
497	U30	--Bumper Guards
497	U35	<b>CLOCK:</b> Electric (Incl w/U7 Gages or U14 Instr)
496	D55	<b>CONSOLE:</b> (Reqs Bucket Seats)
500	CD4	<b>CONTAINER, LITTER</b>
		<b>COVER, CARGO BOX TONNEAU:</b> (N/A D73 Rails)
	19K	--Black
	11K	--White
499	A03	<b>DOOR LOCK SYSTEM, POWER</b>
		<b>EMISSION SYSTEMS:</b> (MUST ORDER ONLY ONE) (See Power Teams Chart)
	YF5	--California Emission Requirements
	NA6	--High Altitude Emission Equipment
	NA2	--Standard Emission Equipment
496	B32	<b>FLOOR COVERING:</b> Mats, Color-Keyed Floor.
493	U67	<b>SAGE PACKAGE:</b> (N/A U14 Instr) (Incls U35 Clock)
	U76	<b>GENERATOR:</b> 61-Amp DelcoTron (Incl w/D60 Air)
496	A01	<b>GLASS, SOFT-RAY TINTED:</b> All Windows
499	J14	<b>INSTRUMENTATION:</b> Special (N/A U7 Gages) (Incls U35 Clock)
498	D09	<b>LIGHTING, AUXILIARY</b>
		<b>MIRRORS:</b>
	D33	--Outside Rearview, LH Remote
497	D35	--Sport, LH Remote and RH Manual
500	D68	--Sport, Twin Remote
500	D34	--Visor Vanity
	D64	--Visor Vanity, Illuminated
497	B93	<b>MOLDINGS:</b> Door Edge Guard
498	V01	<b>RADIATOR, HEAVY-DUTY</b>
		<b>RADIO EQUIPMENT:</b>
496	U63	--AM Radio
498	U69	--AM/FM Radio
500	U58	--AM/FM Stereo Radio
	UM1	--Stereo Tape System w/AM Radio
	UM2	--Stereo Tape System w/AM/FM Stereo Radio
	U06	--Speakers, Dual Front (Reqs U63 or U69 Radio) (Incl w/U58, UM1 or UM2 Radio)
	U76	--Windshield Antenna (Incl w/above Radio Equip w/o U75 Antenna)
500	U75	--Power Antenna (Reqs U63, U69, U58, UM1 or UM2 Radio) (N/A U76 Antenna)
494	D73	<b>RAILS, CARGO BOX SIDE</b>
	DK9	<b>ROOF COVER, VINYL:</b> (See Color and Trim Chart)
	442	<b>SEAT, POWER:</b> Six-way (N/A Bucket Seats) (Driver's Side Only w/50/50 Seat)
498	✓ K30	<b>SPEED CONTROL:</b> Cruise-Master (Reqs MX1 Trans)
496	N41	<b>STEERING, POWER</b>
497	N33	<b>STEERING WHEEL:</b> Comfortilt
		<b>SUSPENSION EQUIPMENT:</b> Suspension
	F40	--Heavy-Duty Front and Rear (N/A F41 Susp)
	F41	--Sport (Reqs V8 Eng)
496	N23	<b>TANK, FUEL:</b> 22 Gallons
	AV3	<b>TIE-DOWNS, CARGO BOX</b>
		<b>TIRES:</b> (B/W: Blackwall, W/S: White Stripe, W/L: White Lettered)
		--Steel Belted Radial Ply (R-14-B)
	OKH	---P205/75 B/W (Base)
	OKJ	---P205/75 W/S
	OKK	---P205/75 W/L
		<b>TRANSMISSIONS:</b> (See Power Teams Chart)
	MM3	---3-Speed Manual (Reqs L26 Eng)
	MM4	---4-Speed Manual (N/A L26 or L25 Eng)
496	MX1	---Automatic
		<b>WHEEL TRIM:</b> (Select Only One)
	N95	---Wheel Covers, Wire
	PS2	---Wheel Covers, Sport--Silver
	55P	---Wheel Covers, Sport--Gold (N/A 15, 22 or 77 paint)
496	D07	--Wheels, Rally. Color-Keyed
499	A31	<b>WINDOWS:</b> Power
499	CD4	<b>WINDSHIELD WIPER EQUIPMENT:</b> Intermittent System

# COLOR AND TRIM SELECTION

# EL CAMINO SUPER SPORT

PLEASE NOTE: The exterior and interior combinations shown in the charts below are the only combinations that are available. (ZP2 override not permitted)

Seat, Headliner and Door Trim Color	Black	Blue	Camel	Car-
Instrument Panel Pad and Carpet Color	Black	Blue	Camel	Car-

Model \_\_\_\_\_ Seat Type \_\_\_\_\_

1AW80	Knit Cloth Bench	BBB1	PDD1	PCC1	PRR1
	Knit Cloth 50/50	BBB3	PDD3	PCC3	PRR3
	Vinyl Bench	BBB1	VDD1	VCC1	VRR1
	Vinyl Bucket		VDD2	VCC2	VRR2
	Vinyl 50/50	BBB3			VRR3

## WITHOUT Z16 BLACK KNIGHT

Exterior Paint Color	Color Code L U	Lower Paint Accent Color and ordering code #	Decal Outline and Lettering Colors	Vinyl Top Color Availability (If Specified)
Black	19 19	Carmine (Met)	77M Red/Black	BB
Black	19 19	Gold (Met)	56M Gold/Black	BB or CC
Black	19 19	Silver	15M Red/Black	BB or CC
Blue, Dark (Met)	29 29	Black	19M Blue/Black	BB or CC
Blue, Light (Met)	22 22	Black	19M Blue/Black	CC or BB
Camel (Met)	63 63	Black	19M Gold/Black	BB
Camel, Dark (Met)	69 69	Black	19M Gold/Black	BB or CC
Camel, Dark (Met)	69 69	Gold (Met)	56M Gold/Black	CC
Camel, Light	61 61	Gold (Met)	56M Gold/Black	CC
Carmine, Dark (Met)	79 79	Black	19M Red/Black	RR
Carmine (Met)	77 77	Black	19M Red/Black	BB
Carmine (Met)	77 77	Dk Carmine (Met)	79M Red/Black	RR
Saffron (Met)	67 67	Black	19M Red/Black	BB
Silver	15 15	Black	19M Red/Black	CC or BB
Silver	15 15	Carmine (Met)	77M Red/Black	RR
Silver	15 15	Gray (Met)	16M Red/Black	CC
White	11 11	Black	19M Red/Black	WW or BB
White	11 11	Black	19M Blue/Black	WW or BB
White	11 11	Black	19M Gold/Black	WW or BB
White	11 11	Gold (Met)	56M Black/Gold	WW or CC

## WITH Z16 BLACK KNIGHT

Exterior Paint Color	Color Code L U				
Black	19 19				

\* Color determined by Exterior Color, Lower Accent Color and Interior Trim Combination.

# Must be ordered. Specify choice in option portion of order form.

## POWER TEAMS

(Refer to next page for option availability and application)

ENGINE OPTION CONDITION		AXLE RATIO	
		2.41	2.73
WITHOUT YF5 CALIFORNIA OR NA6 HIGH ALTITUDE EMISSION			
L26	MM3 or MX1	-	Std
LG3	MM4	-	Std
	MX1	Std	G92
LM1	MM4	-	Std
	MX1	Std	G92
WITH YF5 CALIFORNIA			
LD5	MX1	-	Std
LG3	MX1	Std	G92
LM1	MX1	Std	G92
WITH NA6 HIGH ALTITUDE EMISSION			
LM1	MX1	-	Std

# EL CAMINO SUPER SPORT



Model

1AW80/215 El Camino Super Sport

215 Super Sport (Incls L- Remote and RH Manual Sport Mirrors and Rally Wheels) (D68 Mirrors Optional)

## ← COLOR AND TRIM SELECTION

MUST ORDER ONE: \_\_\_\_\_ ENGINES \_\_\_\_\_

AVAILABLE WITH NA2 STANDARD EMISSION EQUIPMENT

- \_\_\_ L26 3.3 Litre (200 Cu. In.) V6 (Reqs MM3 or MX1 Trans)
- ✓ LQ3 305 Cu. In. V8 (Reqs N41 Steering) (N/A MM3 Trans)
- ✓ LM1 350 Cu. In. V8 (Reqs N41 Steering) (N/A MM3 Trans)

AVAILABLE WITH NA6 HIGH ALTITUDE EMISSION EQUIPMENT

Recommended Above 4000 Foot Altitude

- ✓ LM1 350 Cu. In. V8 (Reqs N41 Steering and MX1 Trans)

CALIFORNIA REGISTRATION (RECS YF5)

- ✓ LQ3 305 Cu. In. V8 (Reqs N41 Steering and MX1 Trans)
- ✓ LM1 350 Cu. In. V8 (Reqs N41 Steering and MX1 Trans)

✓ QUICK-SPEC

**IF TIRE AND/OR TRANSMISSION IN QUICK-SPEC IS NOT DESIRED YOU MUST "PLUS" ANOTHER TIRE AND/OR TRANSMISSION OPTION.**

Super Sport	215	X	X	X	X
Transmission, Automatic	MX1	X	X	X	X
Glass, Soft-Ray Tinted	A01	X	X	X	X
Radio, AM	U63	X	N/INCL		
Air Conditioning, Four-Season	D60	X	X	X	X
Tires, P205/75 R-14-B					
White Lettered	OKK	X	X	X	X
Console (w/Bucket Seats only)	D55	X	X	X	X
Mats, Color-Keyed Floor	B32	X	X	X	X
Steering, Power	N41	X	X	X	X
Steering Wheel, Comfortilt	N33	X	X	X	X
-----					
Bumper Guards	V30	X	X	X	
Bumper Rub Strips	VE5	X	X	X	
Belts, Deluxe	AK1	X	X	X	
Moldings, Door Edge Guard	B93	X	X	X	
Radiator, Heavy Duty	V01	X	X	X	
Radio, AM/FM	U69	X	X	INCL	
Speed Control (w/MX1 Trans only)	K30	X	X	X	
Gage Package	UF7	X	N/INCL		
-----					
Instrumentation	U14		X	X	
Mirrors, Twin Remote	D68		X	X	
Door Lock System, Power	AU3		X	X	
Lighting, Auxiliary	ZJ9		X	X	
Rails, Cargo Box Side	D73		X	X	
Tank, Fuel	N23		X	X	
-----					
Radio, AM/FM Stereo	U58		X		
Power Antenna	U75		X		
Windows, Power	A31		X		
w/S Wiper Equip., Intermittent	CD4		X		
Mirror, Visor Vanity	D34		X		
Container, Litter	D24		X		
-----					

PLEASE REVIEW OPTION RESTRICTIONS BEFORE ORDERING

3-5	OPTION
501	✓ C60 AIR CONDITIONING: Four-Season (LQ5 or LQ6 Eng Reqs N41 Steering) (Incls K76 Gen)
	AXLES, REAR:
	992 --Performance Ratio (See Power Teams Chart) (Reqs V8 Eng and MX1 Trans)
	980 --Positraction
	UA1 BATTERY, HEAVY-DUTY
502	AK1 BELTS, DELUXE: Color-Keyed Seat and Shoulder
	Z16 BLACK KNIGHT: Reqs 19 Paint) (N/A PB2 Wheel Covers, BUMPER EQUIPMENT: Front and Rear
502	VE5 --Bumper Rub Strips
502	V30 --Bumper Guards
	U35 CLOCK: Electric (Incl w/UF7 Gages or U14 Instr)
501	D55 CONSOLE: (Reqs Bucket Seats)
504	D24 CONTAINER, LITTER
	COVER, CARGO BOX TONNEAU: (N/A D73 Rails)
	19K --Black
	11K --White
503	AU3 DOOR LOCK SYSTEM, POWER
	EMISSION SYSTEMS: (MUST ORDER ONLY ONE) (See Power Teams Chart)
	YF5 --California Emission Requirements
	NA6 --High Altitude Emission Equipment
	NA2 --Standard Emission Equipment
501	B32 FLOOR COVERING: Mats, Color-Keyed Floor.
502	UF7 GAGE PACKAGE: (N/A U14 Instr) (Incls U35 Clock)
	K76 GENERATOR: 61-Amp Delcotron (Incl w/D60 Air)
501	A01 GLASS, SOFT-RAY TINTED: All windows
503	U14 INSTRUMENTATION: Special (N/A UF7 Gages) (Incls U35 Clock)
503	ZJ9 LIGHTING, AUXILIARY
	MIRRORS:
503	D68 --Sport, Twin Remote
504	D34 --Visor Vanity
	D64 --Visor Vanity, Illuminated
502	B93 MOLDINGS: Door Edge Guard
502	V01 RADIATOR, HEAVY-DUTY
	RADIO EQUIPMENT:
501	U63 --AM Radio
502	U69 --AM/FM Radio
504	U58 --AM/FM Stereo Radio
	UM1 --Stereo Tape System w/AM Radio
	UM2 --Stereo Tape System w/AM/FM Stereo Radio
	UX6 --Speakers, Dual Front (Reqs L63 or U69 Radio) (Incl w/U58, UM1 or UM2 Radio)
	U76 --Windshield Antenna (Incl w/above Radio Equip w/o U75 Antenna)
504	U75 --Power Antenna (Reqs U63, U69, U58, UM1 or UM2 Radio) (N/A U76 Antenna)
503	D73 RAILS, CARGO BOX SIDE
	... ROOF COVER, TONNEAU: (See Color and Trim Chart)
	A42 SEAT, POWER: 3-Way (N/A Bucket Seats) (Driver's Side Only w/50/50 Seat)
502	✓ K30 SPEED CONTROL: Cruise-Master (Reqs MX1 Trans)
501	N41 STEERING, POWER
501	N33 STEERING WHEEL, Comfortilt
	SUSPENSION EQUIPMENT: Suspension
	F40 --Heavy-Duty Front and Rear (N/A F41 Susp)
	F41 --Sport (Reqs V8 Eng)
503	N23 TANK, FUEL: 22 Gallons
	AV3 TIE-DOWNS, CARGO BOX
	TIRES: (B/W: Blackwall, W/S: White Stripe, w/L: White Lettered)
	--Steel Belted Radial Ply (R-14-B)
	OKH ---P205/75 E/* (Base)
	OKJ ---P205/75 W/S
	OKK ---P205/75 W/L
501	TRANSMISSIONS: (See Power Teams Chart)
	MM3 --3-Speed Manual (Reqs L26 Eng)
	MM4 --4-Speed Manual (N/A L26 or LQ5 Eng)
501	MX1 --Automatic
	WHEEL TRIM: (Select Only One)
	PB2 --Wheel Covers, Sport--Silver
	55P --Wheel Covers, Sport--Gold (N/A 15, 22, 29, or 77 Paint)
504	A31 WINDOWS: Power
504	CD4 WINDSHIELD WIPER EQUIPMENT: Intermittent System

## VINYL ROOF SELECTION

Vinyl Roof	Code	Exterior Color Availability	
Black	BB	Rec: 11, 15, 19, 51 or 67	Acc: 21, 22, 29, 44, 45, 63, 77 or 79
Blue, Light (Met)	BB	Rec: 11, 21, 29 or 29	Acc: 19
Camel, Light	CC	Rec: 51, 63 or 69	Acc: 11, 19 or 67
Carmine, Dark (Met)	RR	Rec: 77	Acc: 77
Green, Light (Met)	GG	Rec: 11, 44 or 45	Acc: 19
Silver	DD	Rec: 15 or 19	Acc: 77
White	WW	Rec: All except 15, 41, 69 or 79	Acc: 15, 51, 69 or 79

Rec = Recommended; Acc = Acceptable

## COLOR AND TRIM SELECTION

PLEASE NOTE: The exterior and interior combinations shown in the chart below and designated as recommended (R), represent the ideal combinations. Those that are shown as acceptable (A), are attractive, but less desirable than the recommended combinations. Orders for additional combinations may be submitted, provided the dealer initials the appropriate order form box (ZP2), as verification that the requested combination is definitely desired. **CAUTION:** Please utilize available color samples when ordering, especially when adding a third color element (Vinyl Top, Exterior Color, Interior Trim) in order to avoid undesirable combinations.

Seat, Headliner and Door Trim Color	Black	Blue	Camel	Carmine	Green
Instrument Panel Pad and Carpet Color	Black	Blue	Camel	Carmine	Green

Model	Seat Type	BBB1	BBB3	BBB5	BBB7	BBB9
1AW80	Knit Cloth Bench	BBB1	BBB3	BBB5	BBB7	BBB9
	Knit Cloth 50/50	BBB7	BBB3	BBB5	BBB7	BBB9
	Vinyl Bench	VBB1	VBB3	VBB5	VBB7	VBB9
	Vinyl Bucket	VBB1	VBB3	VBB5	VBB7	VBB9
	Vinyl 50/50	VBB1	VBB3	VBB5	VBB7	VBB9

Exterior Paint Color	Color Code		Availability					
	15	19	B	A	R	P	A	
Black	15	19	R	A	R	P	A	
Blue, Dark (Met)	20	29	A	P	A			
Blue, Light (Met)	22	22	A	P				
Blue, Light	21	21	A	P				
Camel, Met	43	43	A		R			
Camel, Dark (Met)	49	49	A		R	A		
Camel, Light	41	41	R		R	A		
Carmine, Met	77	77	A		A	R		
Carmine, Dark (Met)	79	79	A		A	R		
Green, Light (Met)	11	11	A		A		B	
Green, Light (Met)	15	15	A		A		B	
Silver, Met	17	17	R	A	A			
Silver	15	15	R	A				
White	11	11	R	P	R	P	P	

Lower Upper

## POWER TEAMS

(Refer to next page for option availability and application)

ENGINE OPTION CONDITION	AXLE RATIO	
	2.41	2.73
WITHOUT YES CALIFORNIA OR NA6 HIGH ALTITUDE EMISSION		
L26 MM3 or MX1	-	Std
LG3 MM4	Std	Std
MX1	Std	992
LM1 MM4	-	Std
MX1	Std	992
WITH YES CALIFORNIA		
LD5 MX1	-	Std
LG3 MX1	Std	992
LM1 MX1	Std	992
WITH NA6 HIGH ALTITUDE EMISSION		
LM1 MX1	-	Std



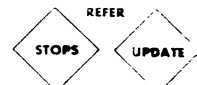

Model  
 #AW30 El Camino

## ← COLOR AND TRIM SELECTION

MUST ORDER ONE: ENGINES

- AVAILABLE WITH NA2 STANDARD EMISSION EQUIPMENT**
- \_\_\_ L26 3.3 Litre (200 Cu. In.) V6 (Reqs MM3 or MX1 Trans)
  - ✓ LG3 305 Cu. In. V8 (Reqs N41 Steering) (N/A MM3 Trans)
  - ✓ LM1 350 Cu. In. V8 (Reqs N41 Steering) (N/A MM3 Trans)

- AVAILABLE WITH NA6 HIGH ALTITUDE EMISSION EQUIPMENT**  
 (Recommended Above 4000 Foot Altitude)
- ✓ LM1 350 Cu. In. V8 (Reqs N41 Steering and MX1 Trans)

- CALIFORNIA REGISTRATION (REQS YF5)**
- ✓ LD5 231 Cu. In. V6 (Reqs MX1 Trans)
  - ✓ LG3 305 Cu. In. V8 (Reqs N41 Steering and MX1 Trans)
  - ✓ LM1 350 Cu. In. V8 (Reqs N41 Steering and MX1 Trans)

✓ QUICK-SPEC

**IF TIRE AND/OR TRANSMISSION IN QUICK-SPEC IS NOT DESIRED YOU MUST "PLUS" ANOTHER TIRE AND/OR TRANSMISSION OPTION.**

		4	4	4	4
		9	9	9	9
		1	2	3	4
		A	B	C	C
Transmission, Automatic	MX1	X	X	X	X
Glass, Soft-Ray Tinted	A01	X	X	X	X
Radio, AM	U63	X	X	N/INCL	
Air Conditioning, Four-Season	C60	X	X	X	X
Tires, P205/75 R-14-B					
White Stripes	QKJ	X	X	X	X
Console (w/Bucket Seats only)	D55	X	X	X	X
Mats, Color-Keyed Floor	B32	X	X	X	X
Steering, Power	N41	X	X	X	X
Wheels, Rally	ZJ7	X	X	X	X
-----					
Moldings, Body Side Deluxe	BW2	X	X	X	X
Bumper Guards	V30	X	X	X	X
Clock, Electric	U35	X	N/INCL		
Mirrors, LH Remote and RH Manual Sport	D35	X	X	X	X
Moldings, Door Edge Guard	B93	X	X	X	X
Steering Wheel, Comfortilt	N33	X	X	X	X
Belts, Deluxe	AK1	X	X	X	X
Bumper Rub Strips	YE5	X	X	X	X
-----					
Lighting, Auxiliary	ZJ9	X	X	X	
Radiator, Heavy-Duty	V01	X	X	X	
Speed Control (w/MX1 Trans only)	K30	X	X	X	
Gage Package	UF7	X	X	X	NOT INCL
Radio, AM/FM	U69	X	X	X	NOT INCL
-----					
Door Lock System, Power	AU3	X	X		
Rails, Cargo Box Side	D73	X	X		
Windows, Power	A31	X	X		
W/S Wiper Equip, Intermittent	CD4	X	X		
Tank, Fuel	N23	X	X		
-----					
Mirror, Visor Vanity	D34	X			
Container, Litter	D24	X			
Power Antenna	U75	X			
Radio, AM/FM Stereo	U58	X			
Instrumentation	U14	X			

PLEASE REVIEW OPTION RESTRICTIONS BEFORE ORDERING

- OPTION**
- 491 ✓ C60 AIR CONDITIONING: Four Season (LD5 or L26 Eng Reqs N41 Steering) (Incls K76 Gen)
  - AXLES, REAR:**
  - 492 --Performance Ratio (See Power Teams Chart) (Reqs V8 Eng and MX1 Trans)
  - 492 330 --Positraction
  - 492 4A1 BATTERY, HEAVY-DUTY
  - 492 4K1 BELTS, DELUXE: Color-Keyed Seat and Shoulder
  - BUMPER EQUIPMENT:** Front and Rear
  - 492 YE5 --Bumper Rub Strips
  - 492 V30 --Bumper Guards
  - 492 U35 CLOCK: Electric (Incl w/UF7 Gages or U14 Instr)
  - 491 D55 CONSOLE: (Reqs Bucket Seats)
  - 495 D24 CONTAINER, LITTER
  - COVER, CARGO BOX TONNEAU:** (N/A D73 Rails)
  - 19K --Black
  - 11K --White
  - 494 AU3 DOOR LOCK SYSTEM, POWER
  - EMISSION SYSTEMS:** (MUST ORDER ONLY ONE) (See Power Teams Chart)
  - YF5 --California Emission Requirements
  - NA6 --High Altitude Emission Equipment
  - NA2 --Standard Emission Equipment
  - 491 B32 FLOOR COVERING: Mats, Color-Keyed Floor.
  - 493 JF7 GAGE PACKAGE: (N/A U14 Instr) (Incls U35 Clock)
  - K76 GENERATOR: 61-Amp Delcotron (Incl w/C60 Air)
  - 491 A01 GLASS, SOFT-RAY TINTED: All Windows
  - 495 L14 INSTRUMENTATION: Special (N/A UF7 Gages) (Incls U35 Clock)
  - 493 ZJ9 LIGHTING, AUXILIARY
  - MIRRORS:**
  - D33 --Outside Rearview, LH Remote
  - 492 D35 --Sport, LH Remote and RH Manual
  - 495 D38 --Sport, Twin Remote
  - D34 --Visor Vanity
  - D64 --Visor Vanity, Illuminated
  - MOLDINGS:**
  - 492 BW2 --Body Side, Deluxe (See Page 8 for Standard Color)
  - 492 BX8 --Front Fender, Body Side and Tailgate
  - 493 B93 --Door Edge Guard
  - 493 V01 RADIATOR, HEAVY-DUTY
  - RADIO EQUIPMENT:**
  - 491 U63 --AM Radio
  - 493 U69 --AM/FM Radio
  - 495 U58 --AM/FM Stereo Radio
  - UM1 --Stereo Tape System w/AM Radio
  - UM2 --Stereo Tape System w/AM/FM Stereo Radio
  - UX6 --Speakers, Dual Front (Reqs U63 or U69 Radio) (Incl w/U58, UM1 or UM2 Radio)
  - U76 --Windshield Antenna (Incl w/above Radio Equip w/o U75 Antenna)
  - 495 U75 --Power Antenna (Reqs U63, U69, U58, UM1 or UM2 Radio) (N/A U76 Antenna)
  - 494 D73 RAILS, CARGO BOX SIDE
  - ... ROOF COVER, VINYL: (See Color and Trim Chart)
  - 442 SEAT, POWER: Six-way (N/A Bucket Seats) (Driver's Side Only w/50/50 Seat)
  - 493 ✓ K30 SPEED CONTROL: Cruise-Master (Reqs MX1 Trans)
  - 491 N41 STEERING, POWER
  - 492 N33 STEERING WHEEL: Comfortilt
  - SUSPENSION EQUIPMENT: Suspension**
  - F40 --Heavy-Duty Front and Rear (N/A F41 Susp)
  - F41 --Sport (Reqs V8 Eng)
  - 494 N23 TANK, FUEL: 22 Gallons
  - AV3 TIE-DOWNS, CARGO BOX
  - TIRES:** (B/W: Blackwall, W/S: White Stripe, W/L: White Lettered)
  - QKH ---P205/75 B/W (Base)
  - 491 QKJ ---P205/75 W/S
  - QKK ---P205/75 W/L
  - TRANSMISSIONS:** (See Power Teams Chart)
  - MM3 --3-Speed Manual (Reqs L26 Eng)
  - MM4 --4-Speed Manual (N/A L26 or LD5 Eng)
  - 491 MX1 --Automatic
  - WHEEL TRIM:** (Select Only One)
  - 495 --Wheel Covers, wire
  - FB2 --Wheel Covers, Sport--Silver
  - 55P --Wheel Covers, Sport--Gold (N/A 15, 21, 22, 29, 44 or 77 paint)
  - 491 ZJ7 --Wheels, Rally, Color-Keyed
  - 494 A31 WINDOWS: Power
  - 494 CD4 WINDSHIELD WIPER EQUIPMENT: Intermittent System

## BODY SIDE MOLDING CHART

### RPO BW2 (MUST BE SPECIFIED)

N/A Z15 Super Sport or D91 Conquista

WITH VINYL ROOF

Exterior Paint Color and Code		Vinyl Roof Color						
		Black	Blue Light (Met)	Camel Light	Carmine Dark (Met)	Green Light (Met)	Silver	White
		BB	DD	CC	RR	GG	QQ	WW
Black	19 Molding	Black	Blue	Black	?	Green	Black	Black
Blue, Dark (Met)	29 Molding	Black	Blue	?	?	?	?	Black
Blue, Light (Met)	22 Molding	Black	Blue	?	?	?	?	Blue
Blue, Light	21 Molding	Blue	Blue	?	?	?	?	Blue
Camel (Met)	63 Molding	Camel	?	Camel	?	?	?	Camel
Camel, Dark (Met)	69 Molding	?	?	Camel	?	?	?	Black
Camel, Light	61 Molding	Black	?	Camel	?	?	?	Camel
Carmine (Met)	77 Molding	Carmine	?	?	Carmine	?	?	Carmine
Carmine, Dark (Met)	79 Molding	Carmine	?	?	Carmine	?	?	Carmine
Green, Light (Met)	44 Molding	Green	?	?	?	Green	?	Green
Green, Medium (Met)	45 Molding	Green	?	?	?	Green	?	Green
Patron (Met)	67 Molding	Black	?	Black	?	?	?	Black
Silver	15 Molding	Black	?	?	?	?	Black	Black
White	11 Molding	Black	Blue	Camel	?	Green	Black	Black

WITHOUT VINYL ROOF

Exterior Paint Color	Color Code L	Color Code U	Molding #BW2
Black	19	19	Black
Blue, Dark (Met)	29	29	Black
Blue, Light (Met)	22	22	Blue
Blue, Light	21	21	Blue
Camel (Met)	63	63	Camel
Camel, Dark (Met)	69	69	Black
Camel, Light	61	61	Camel
Carmine (Met)	77	77	Carmine
Carmine, Dark (Met)	79	79	Carmine
Green, Light (Met)	44	44	Green
Green, Medium (Met)	45	45	Green
Patron (Met)	67	67	Black
Silver	15	15	Black
White	11	11	Black

L=Lower U=Upper

? When R2 is specified to override Vinyl Roof and Exterior Color, BW2 Molding Color is Black unless otherwise specified.

= If the color of molding (BW2) as shown in the charts is not desired, order one of the following options instead of BW2 Molding.

190=Black; 220=Light Blue; 440=Light Green; 610=Light Camel; 790=Dark Carmine